

# AC BOUNDARY-SCAN FAULT COVERAGE

## ON BASIC LVDS

Original documentation has been updated for better readability including fault injection model.

### 1 Fault Injection Model

Figure 1 shows fault injection model for spice simulation.

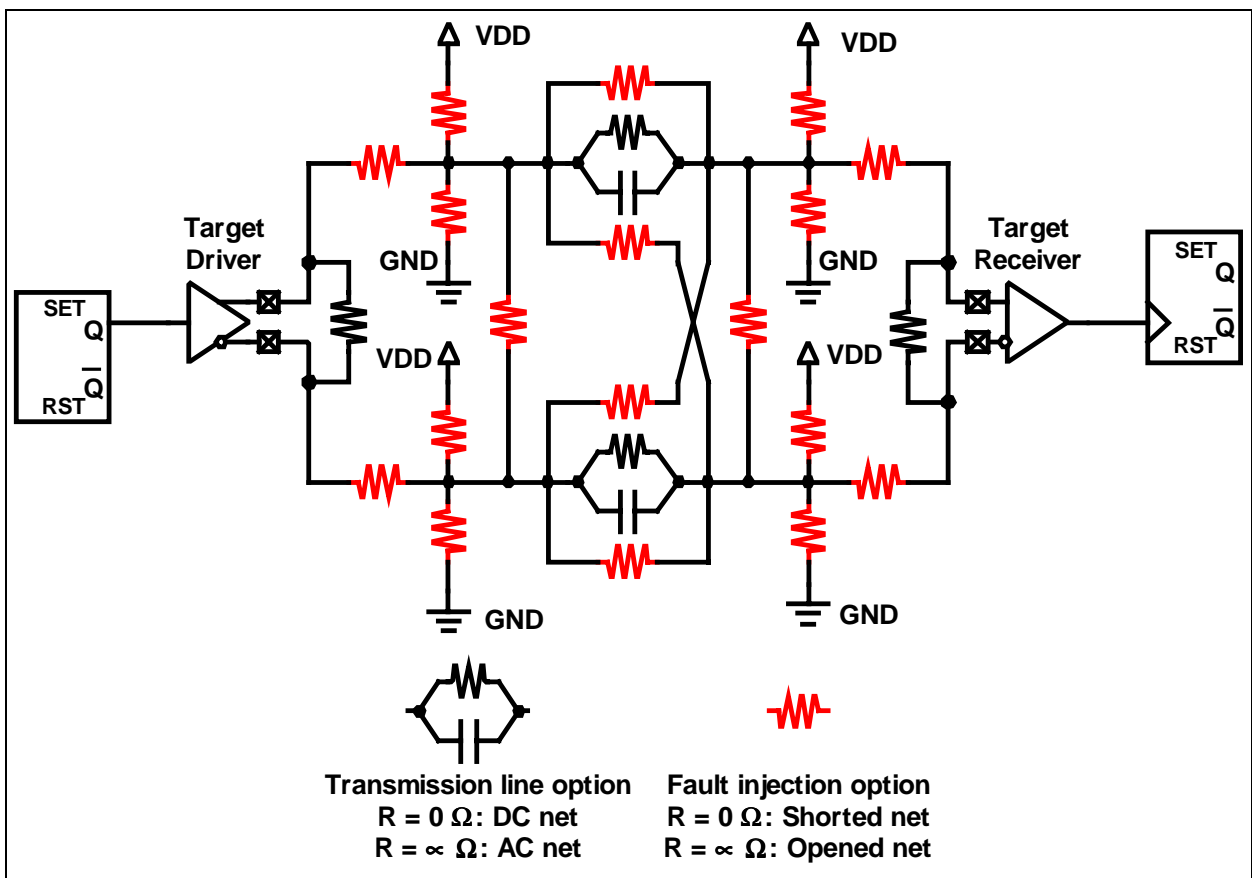

Figure 1 Faults inject points in LVDS pair

## 2 Fault Coverage Summary

The tables below summarize the fault coverage on types injected on LVDS. The coverage analysis is based on spice simulation. The spice results are shown in next section.

Number	Fault Type	Signal	Coverage		Comments
			AC	AC + DC	
1	Open	Positive before CAP	Yes	Yes	
2	Open	Positive after CAP	Yes	Yes	
3	Open	Negative before CAP	Yes	Yes	
4	Open	Negative after CAP	Yes	Yes	
5	Short	Positive before CAP and Negative after CAP	Yes	Yes	
6	Short	Positive after CAP and Negative before CAP	Yes	Yes	
7	Short	Positive before CAP and Positive after CAP	No	Yes	Combining with DC test might detect this fault
8	Short	Negative before CAP and Negative after CAP	No	Yes	Combining with DC test might detect this fault
9	Stuck-0	Positive before CAP	Yes/No(?)	Yes/No(?)	Require longer simulation, See waveform
10	Stuck-1	Positive before CAP	Yes/No	Yes/No	Depend on Stuck voltage level
11	Stuck-0	Positive after CAP	Yes	Yes	
12	Stuck-1	Positive after CAP	Yes/No	Yes/No	Depend on Stuck voltage level
13	Stuck-0	Negative before CAP	Yes/No(?)	Yes/No(?)	Require longer simulation, See waveform
14	Stuck-1	Negative before CAP	Yes/No	Yes/No	Depend on Stuck voltage level
15	Stuck-0	Negative after CAP	Yes	Yes	
16	Stuck-1	Negative after CAP	Yes/No	Yes/No	Depend on Stuck voltage level

**Table 1 Fault injection and coverage for AC coupled differential lines**

### 3 Spice Results

#### 3.1 No Fault

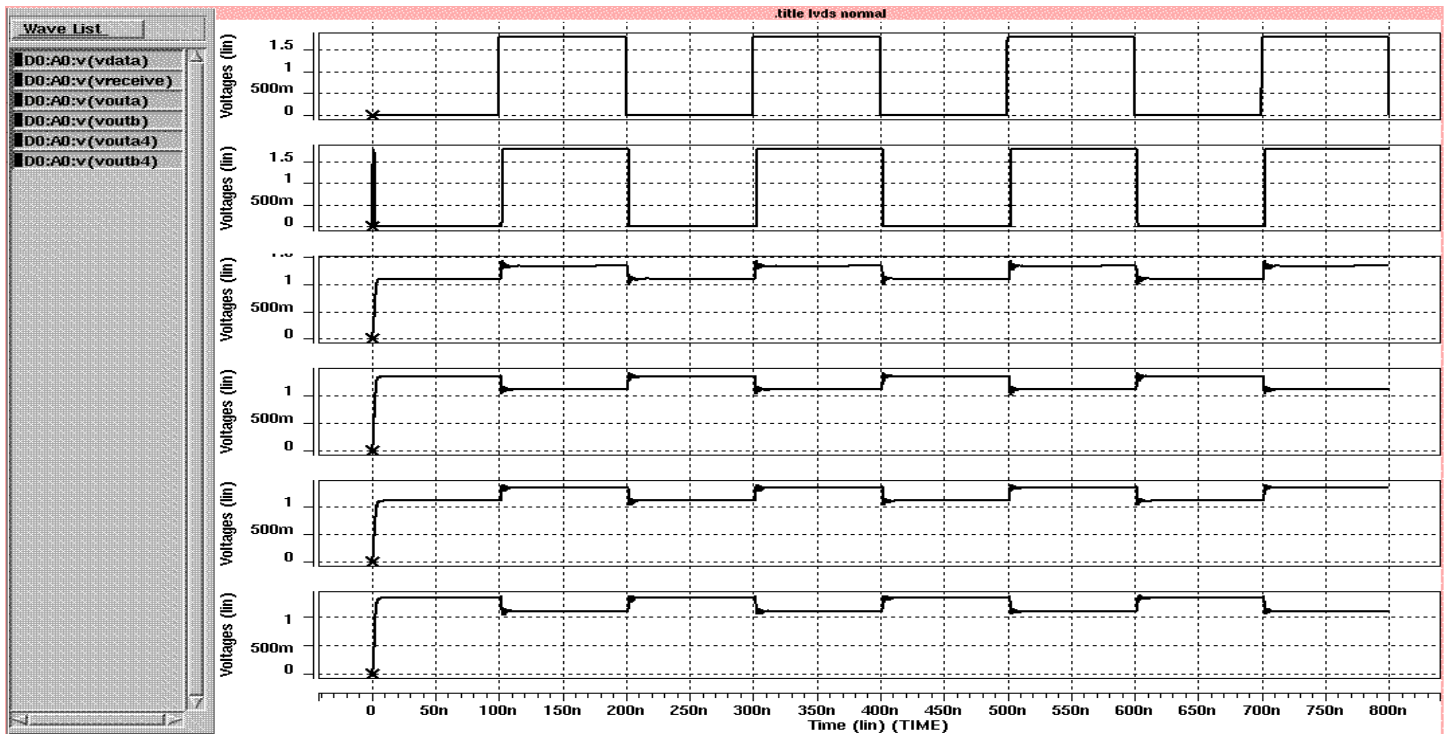

#### 3.2 Fault 1 (Open: Positive before CAP: Detected)

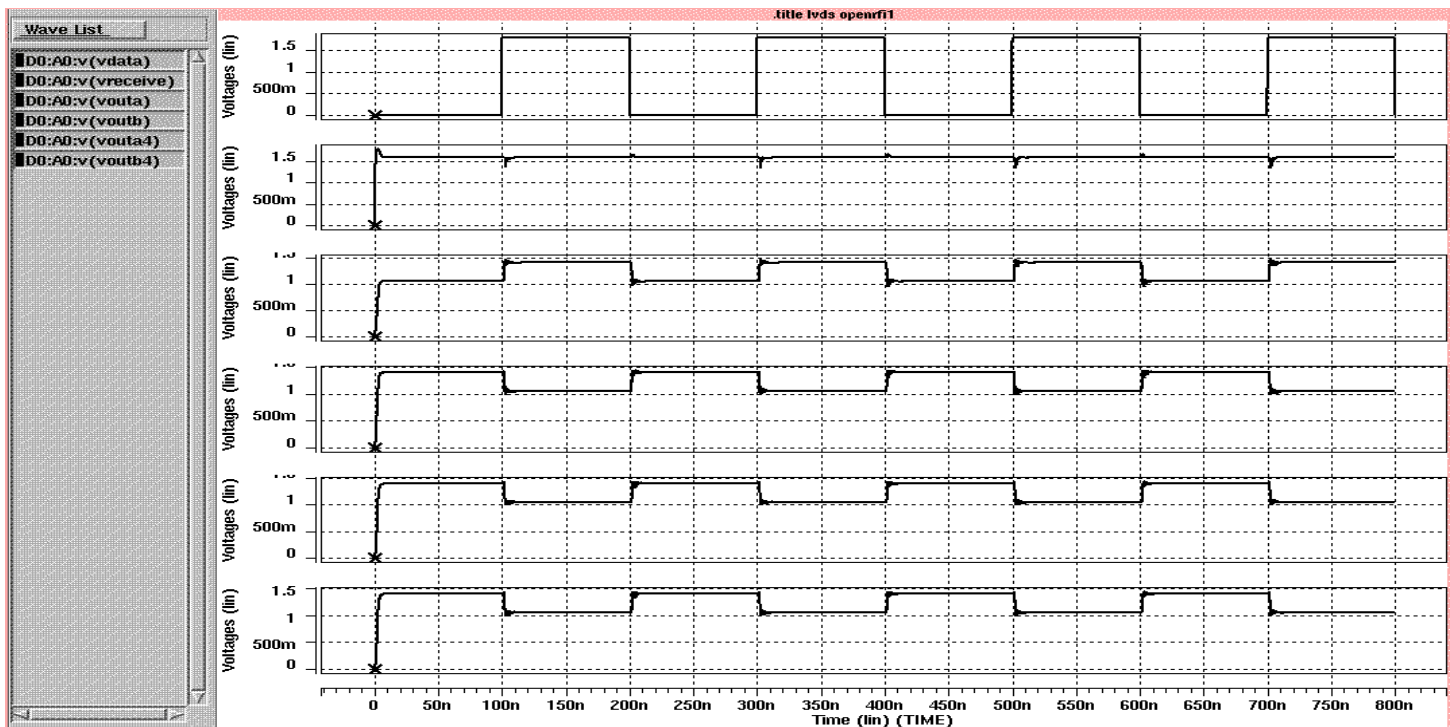

### 3.3 Fault 2 (Open: Positive after CAP: Detected)

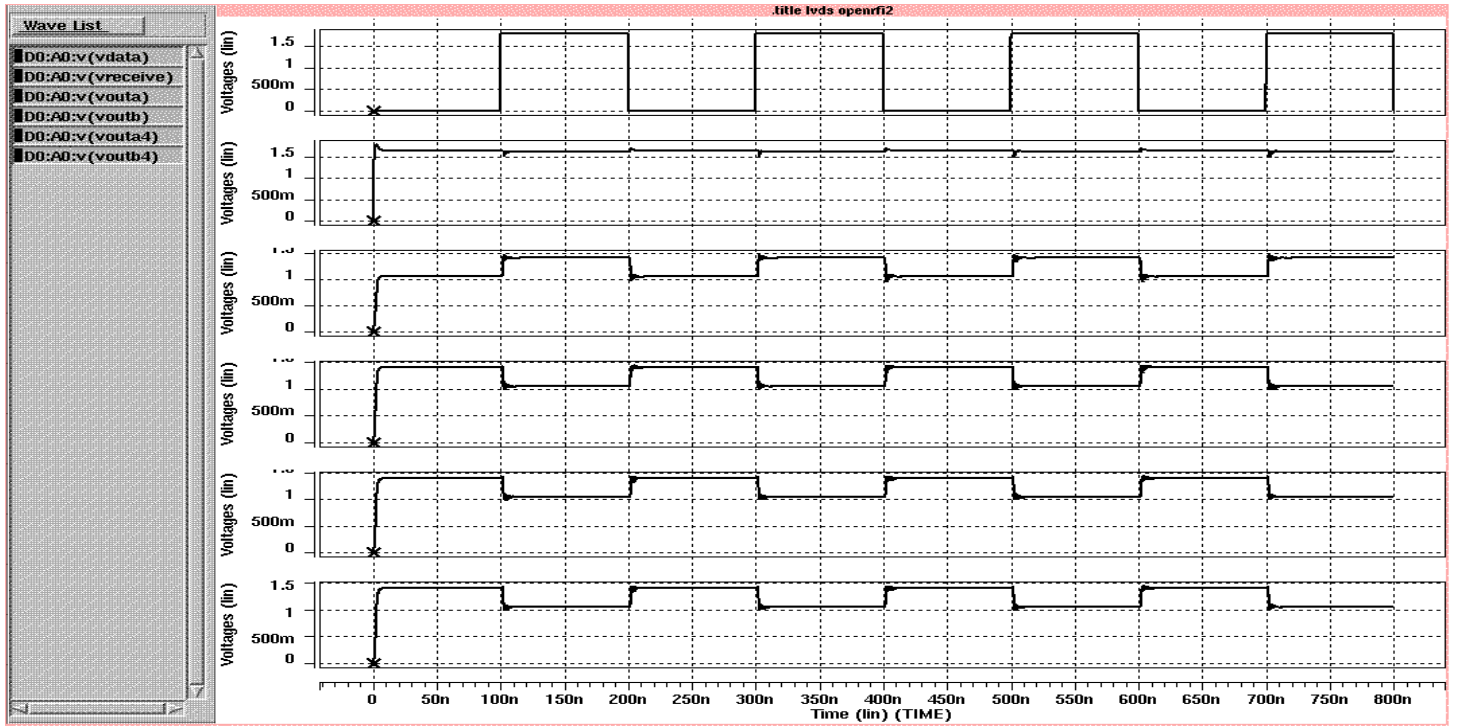

### 3.4 Fault 3 (Open: Negative before CAP: Detected)

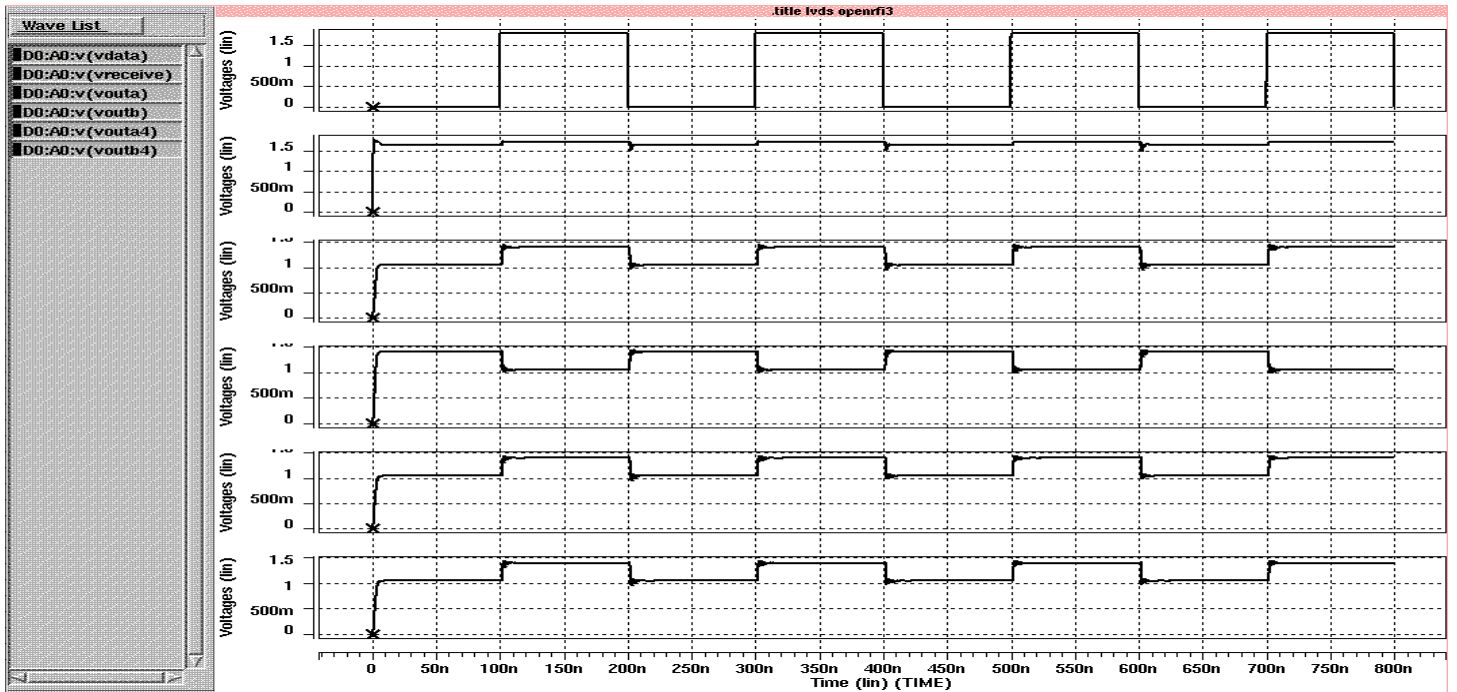

### 3.5 Fault 4 (Open: Negative after CAP: Detected)

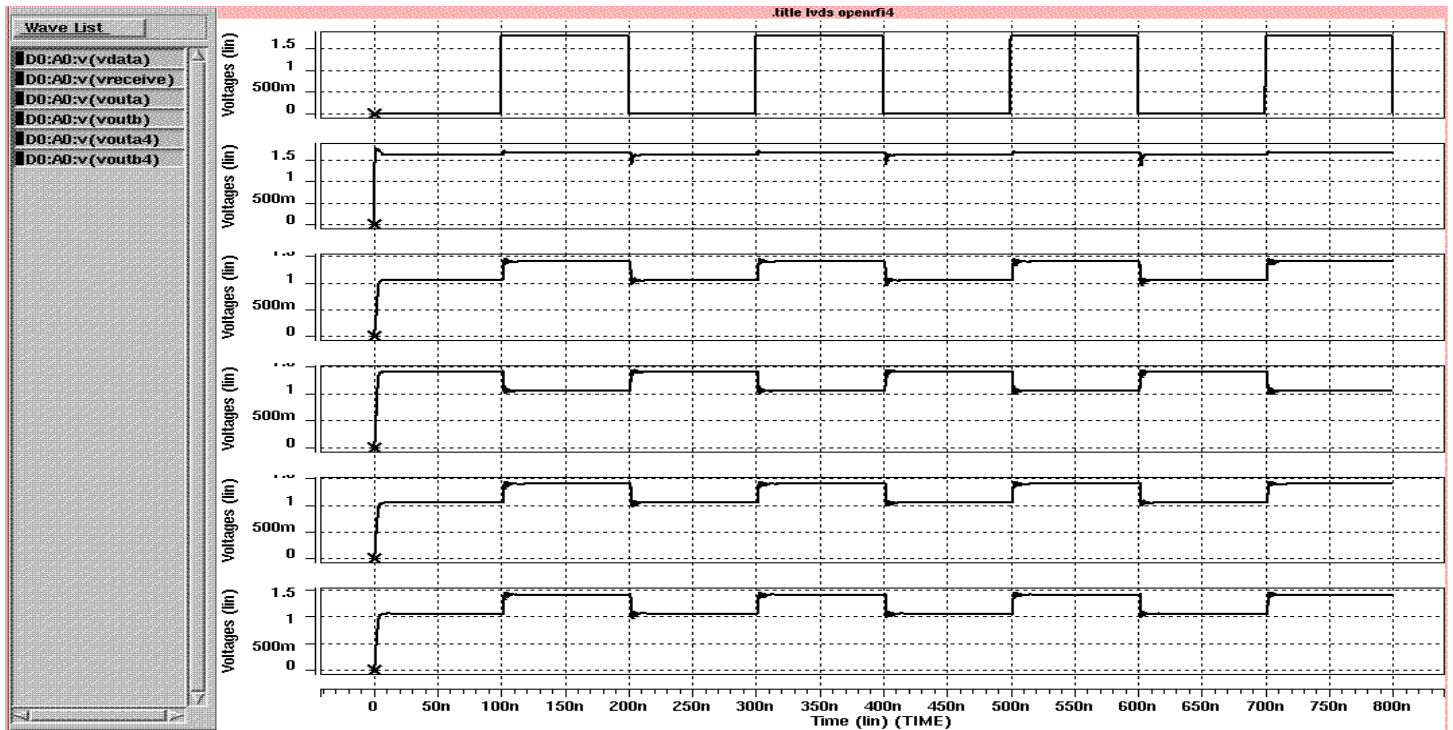

### 3.6 Fault 5 (Short: Positive before CAP and negative after CAP: Detected)

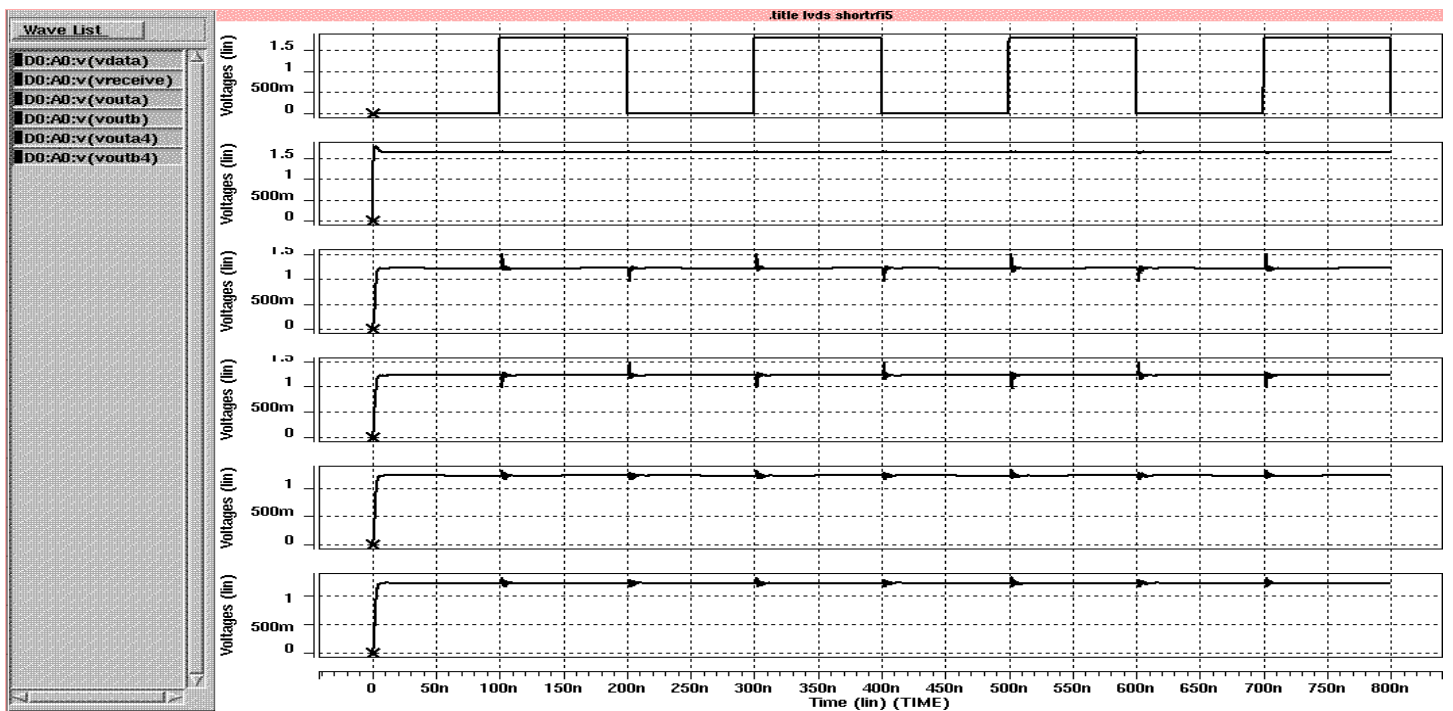

### 3.7 Fault 6 (Short: Positive after CAP and negative before CAP: Detected)

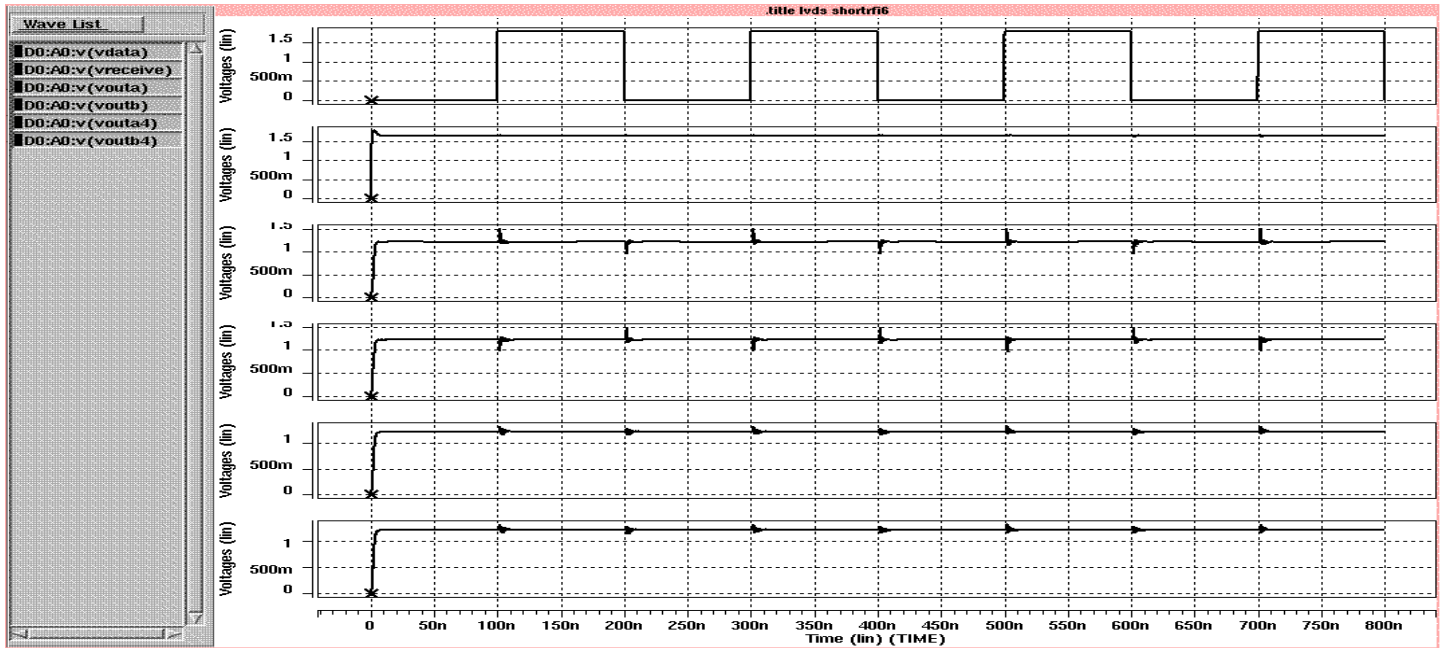

### 3.8 Fault 7 (Short: Positive before CAP and positive after CAP: Not Detected)

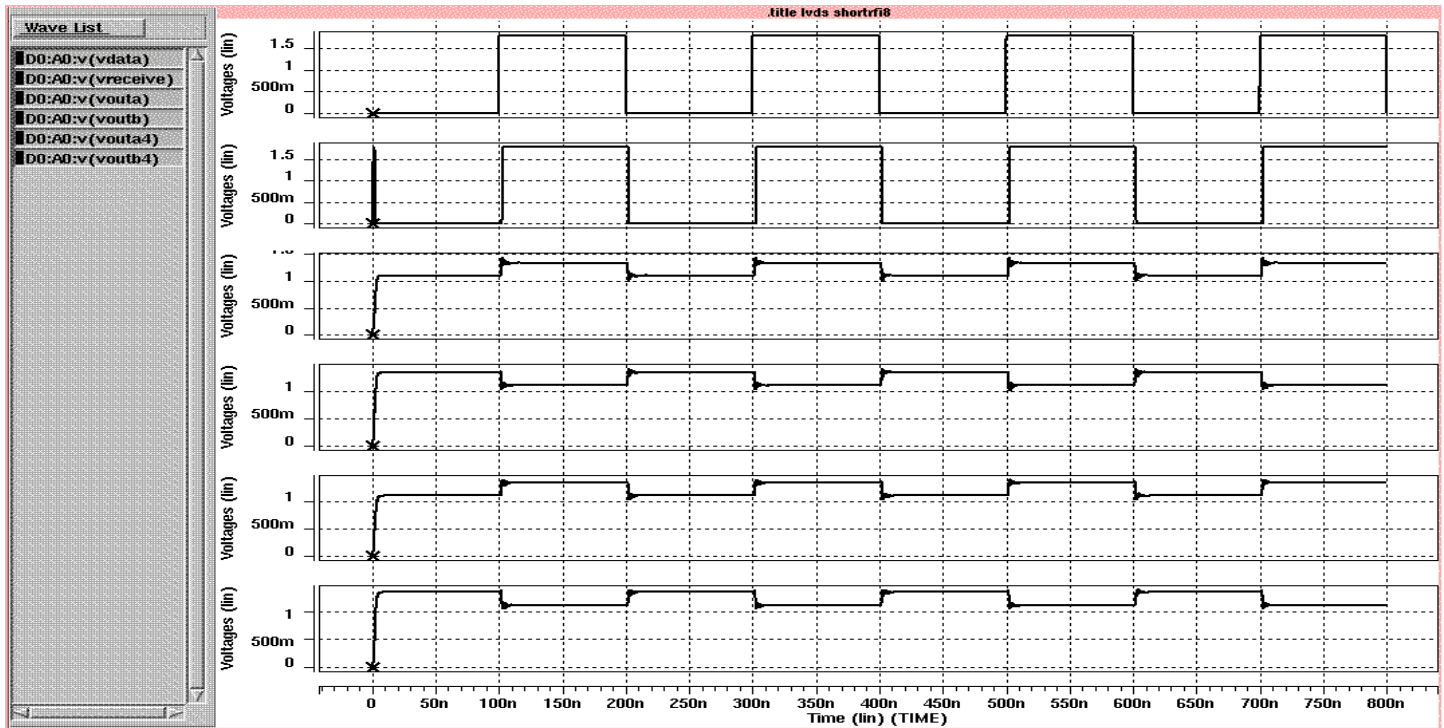

### 3.9 Fault 8 (Short: Negative before CAP and Negative after CAP: Not Detected)

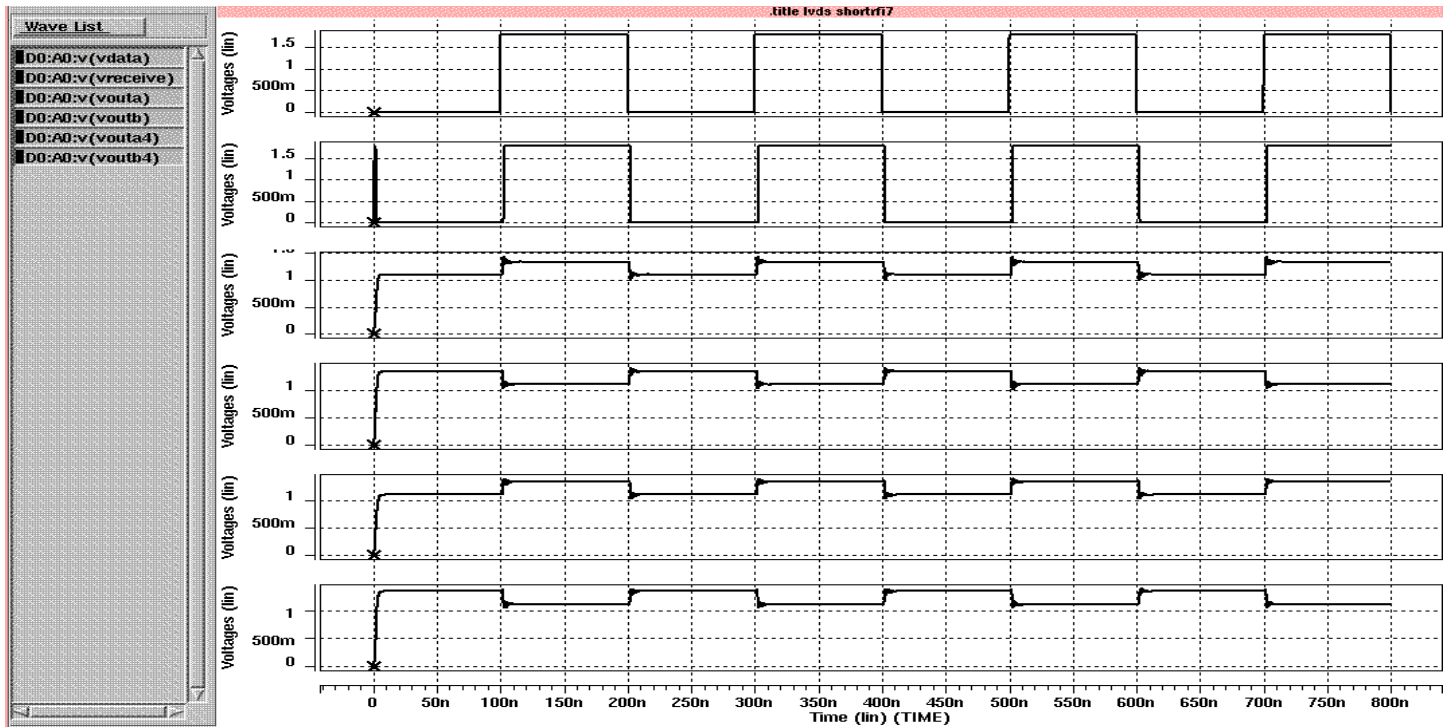

### 3.10 Fault 9 (Stuck-At-0: Positive before CAP: Not Detected)

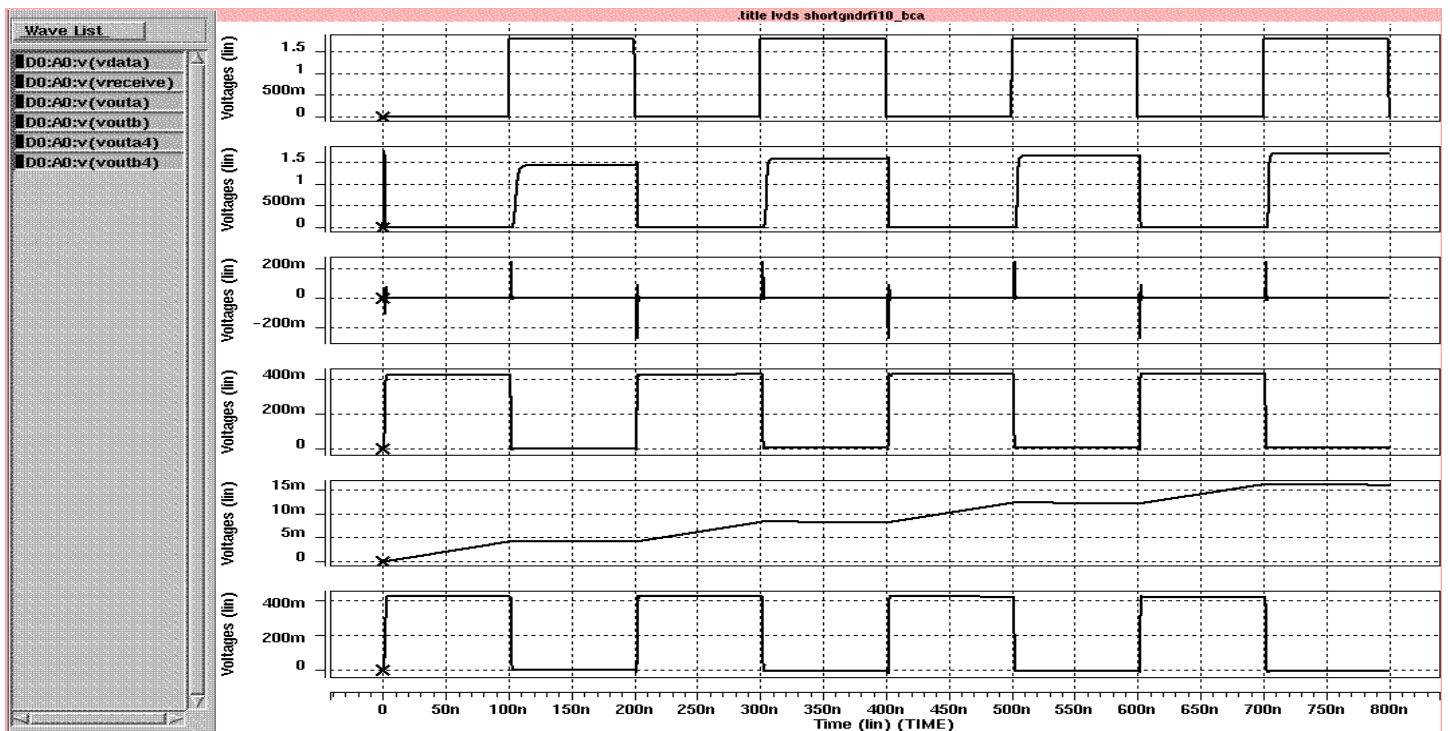

### 3.11 Fault 10 (Stuck-At-1: Positive before CAP)

#### 3.11.1 Stuck to Common Mode Voltage (Not Detected)

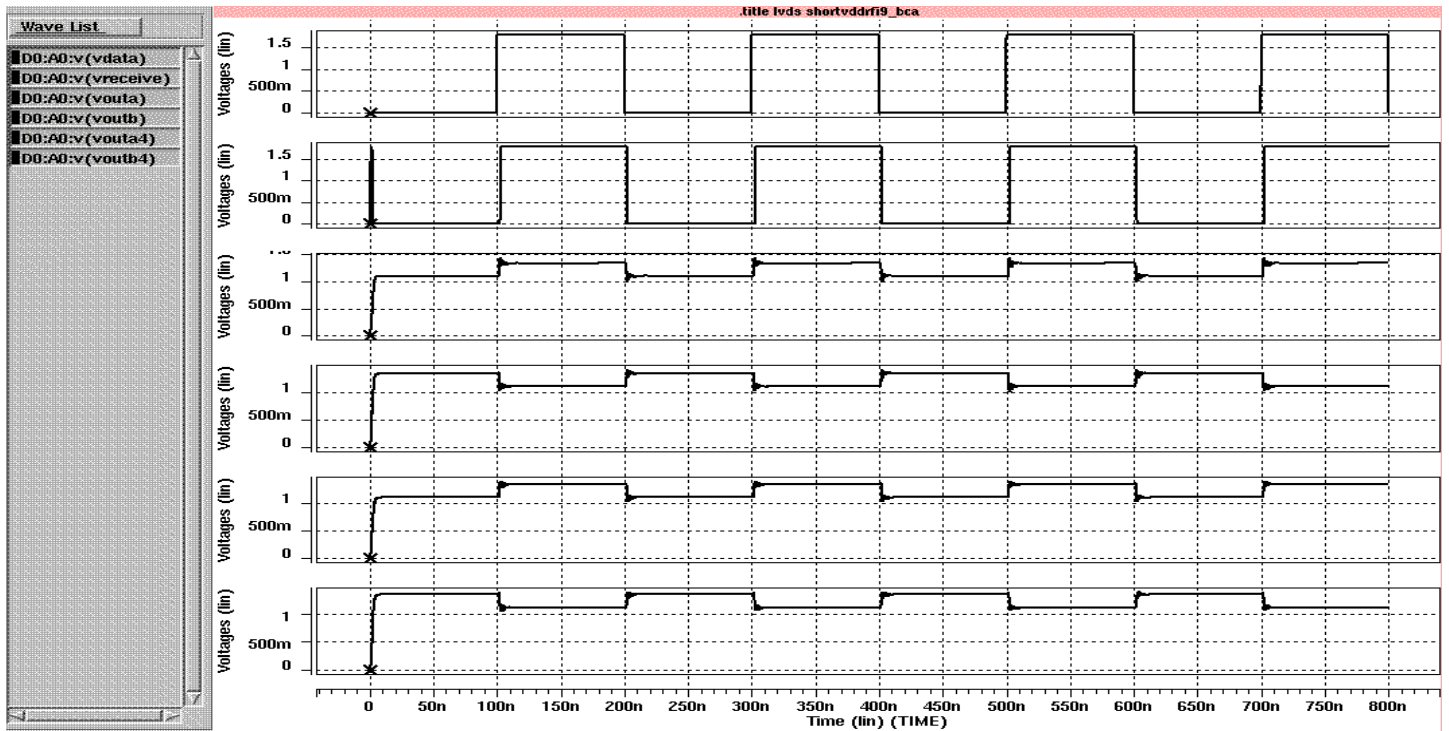

#### 3.11.2 Stuck to 2.5V (Detected)

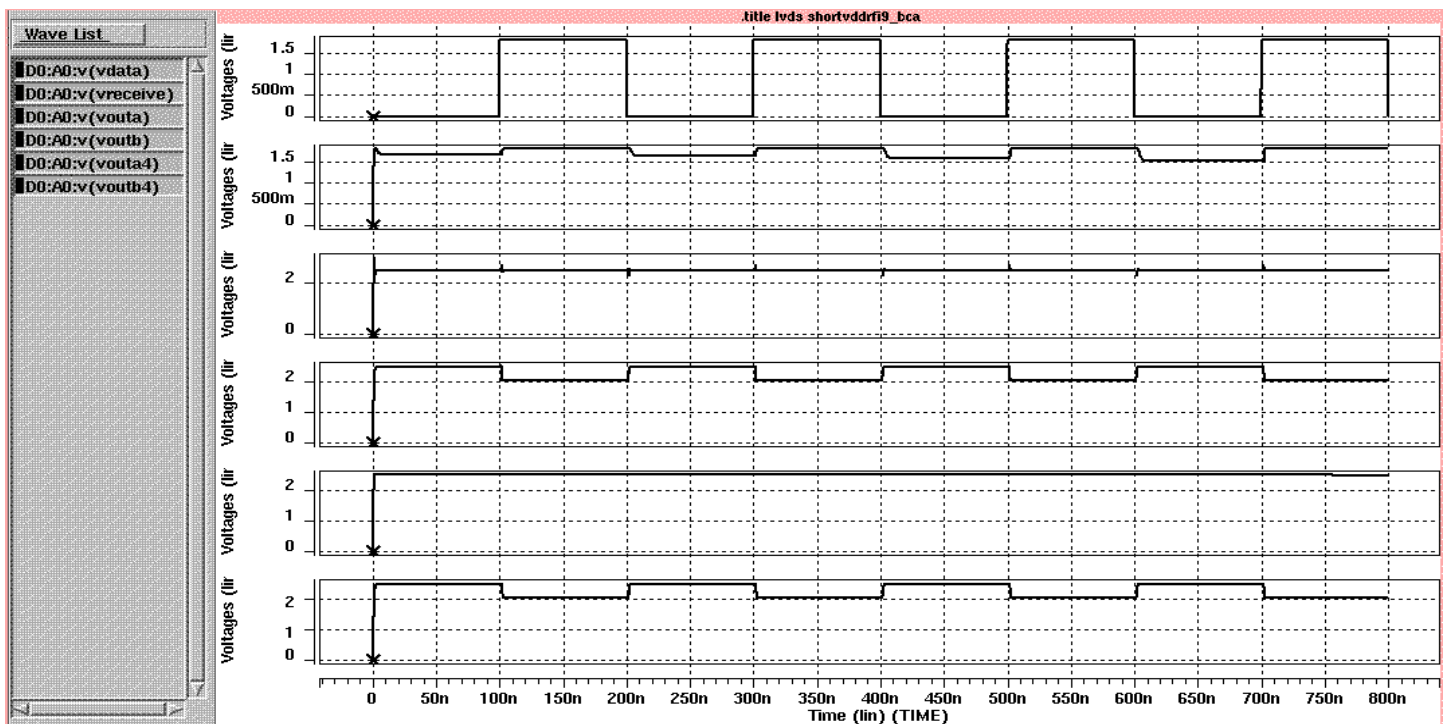

### 3.12 Fault 11 (Stuck-At-0: Positive after CAP: Detected)

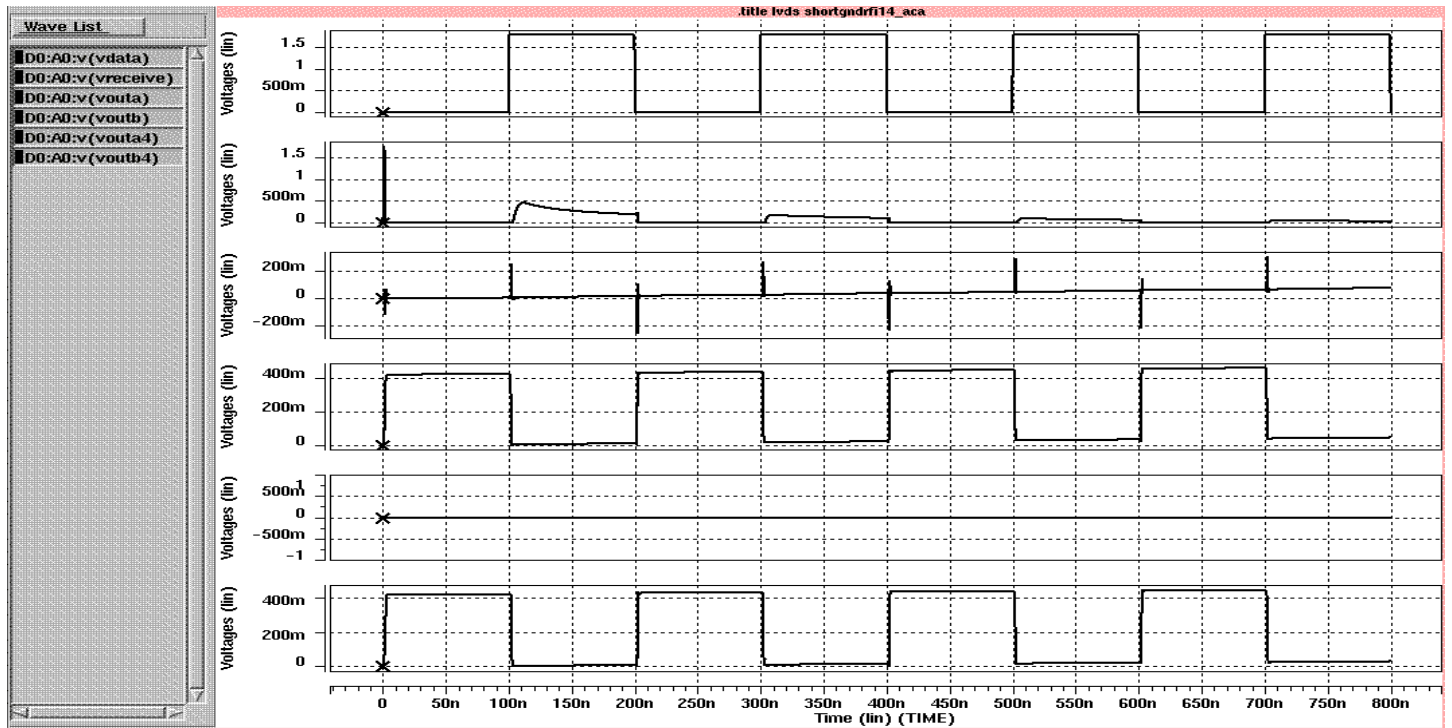

### 3.13 Fault 12 (Stuck-At-1: Positive after CAP)

#### 3.13.1 Stuck to common mode voltage (Not Detected)

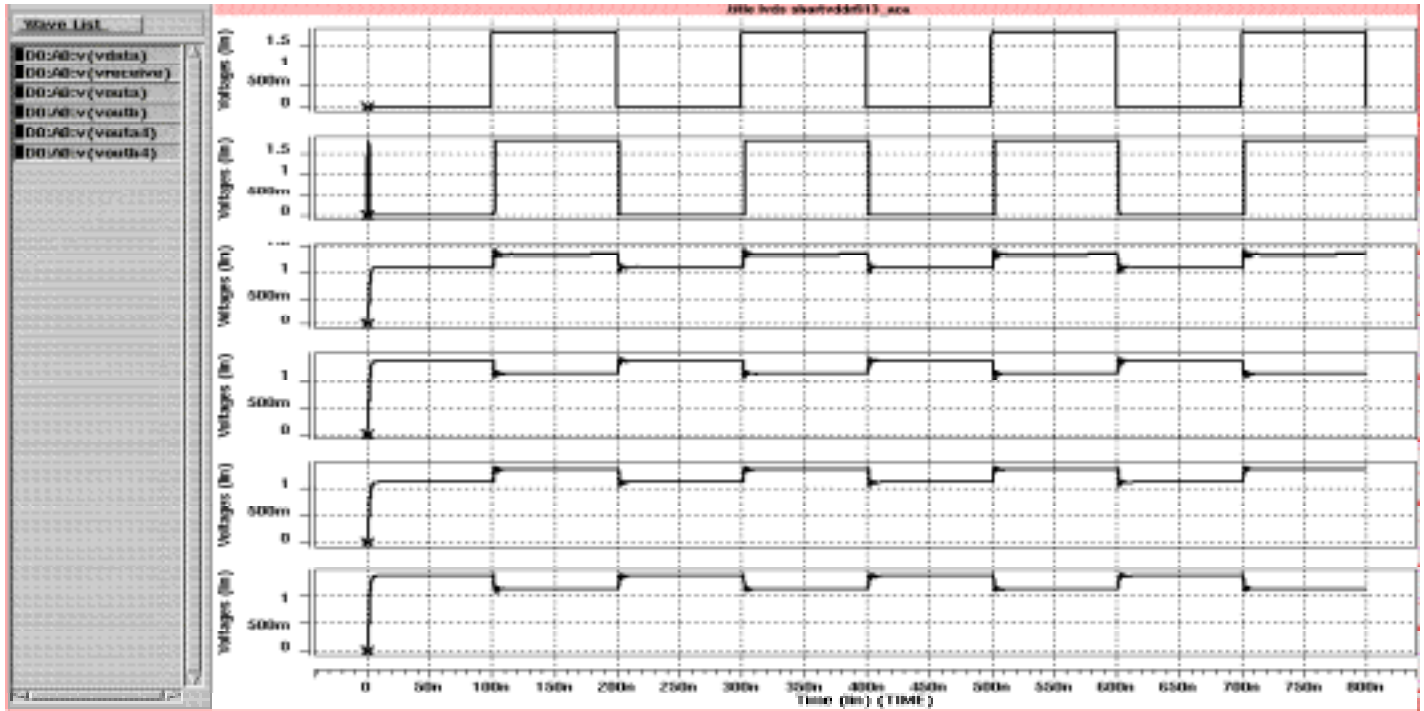

#### 3.13.2 Stuck to 2.5V (Detected)

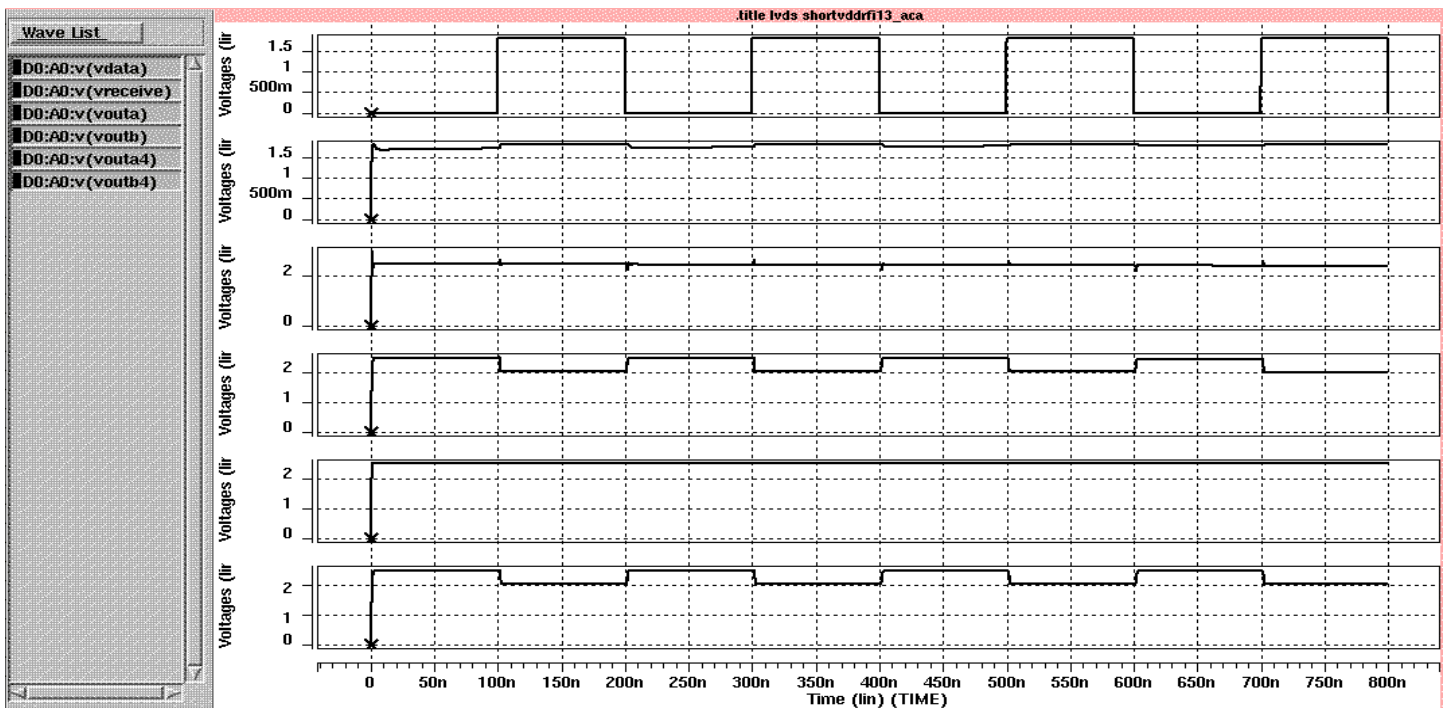



### 3.15 Fault 14 (Stuck-At-1: Negative before CAP)

#### 3.15.1 Stuck to common mode voltage (Not Detected)

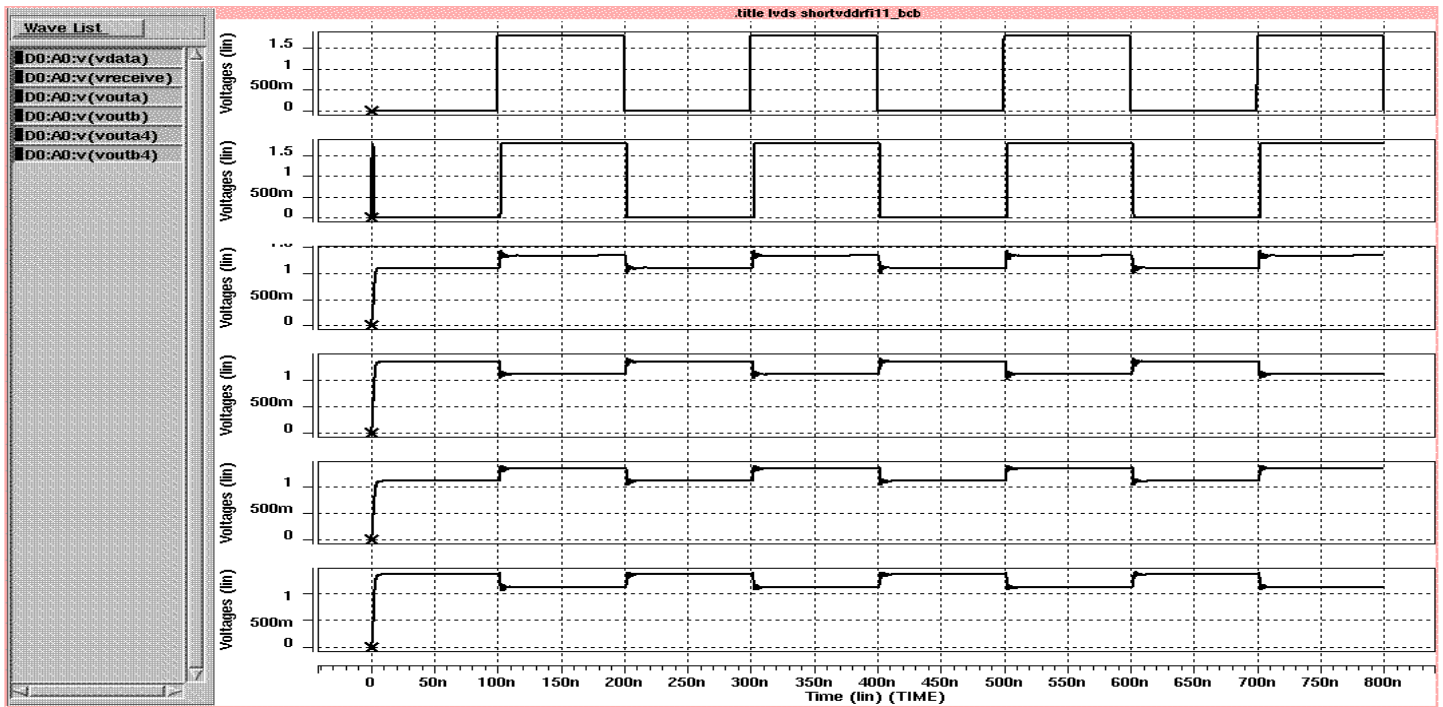

#### 3.15.2 Stuck to 2.5V and above (Detected, Here is marginal voltage)

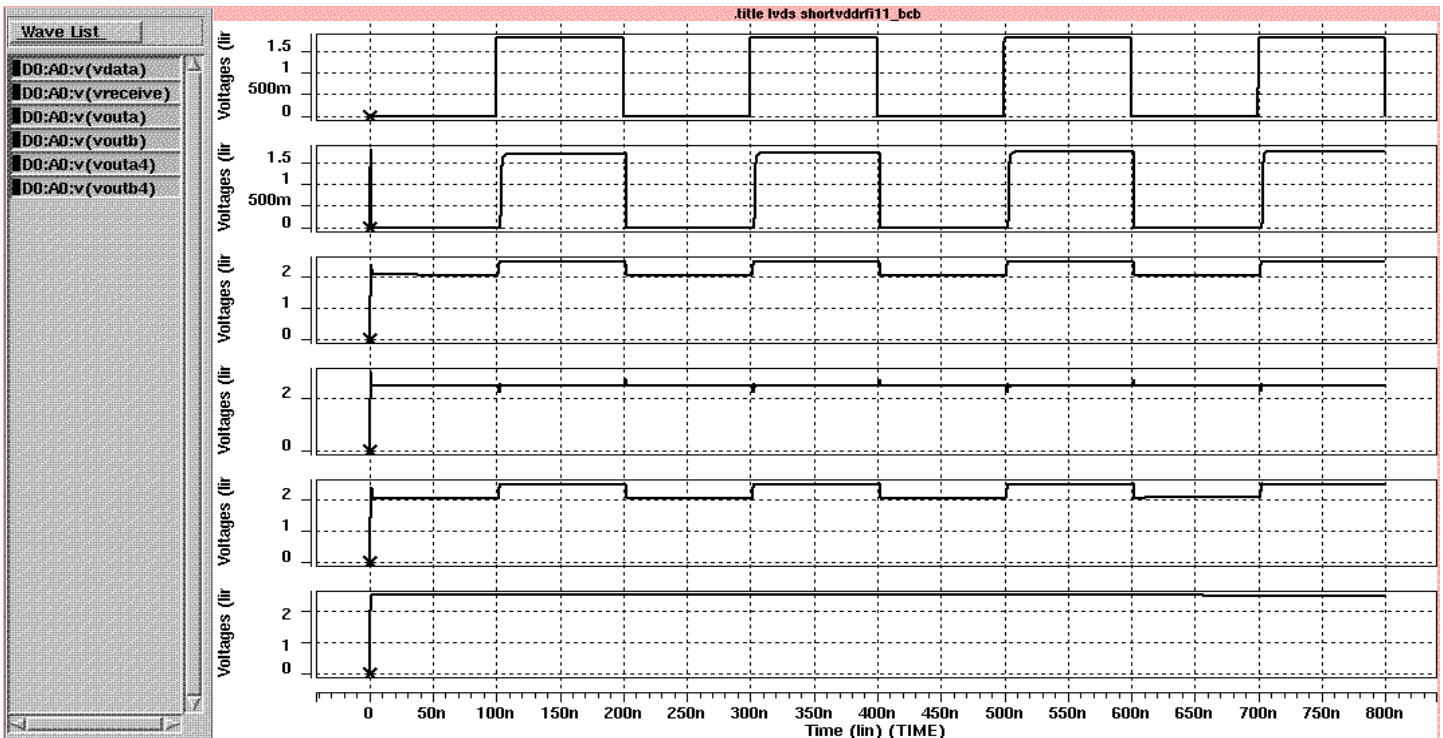

### 3.16 Fault 15 (Stuck-At-0: Negative after CAP: Detected)

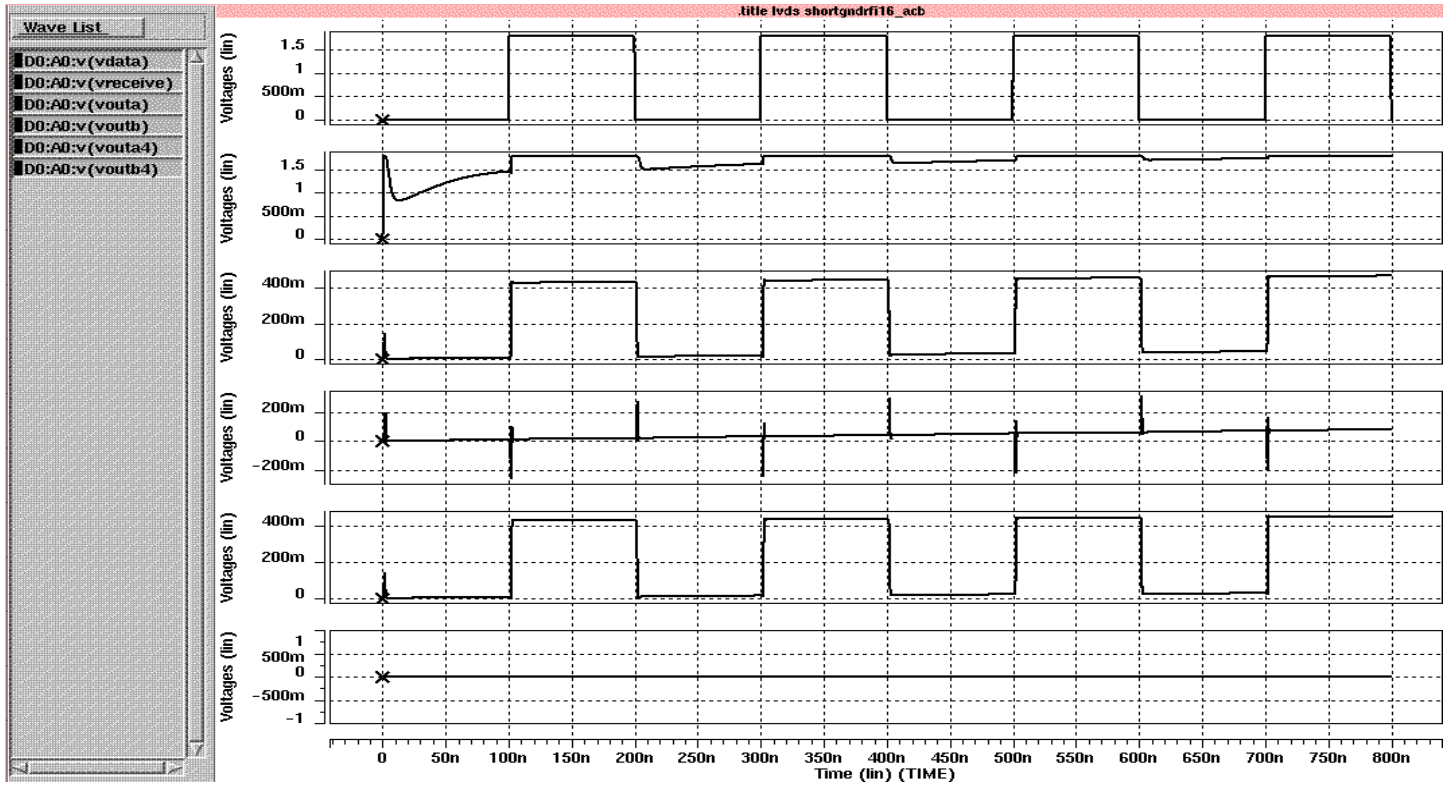

### 3.17 Fault 16 (Stuck-At-1: Negative after CAP)

#### 3.17.1 Stuck to common mode voltage: Not Detected

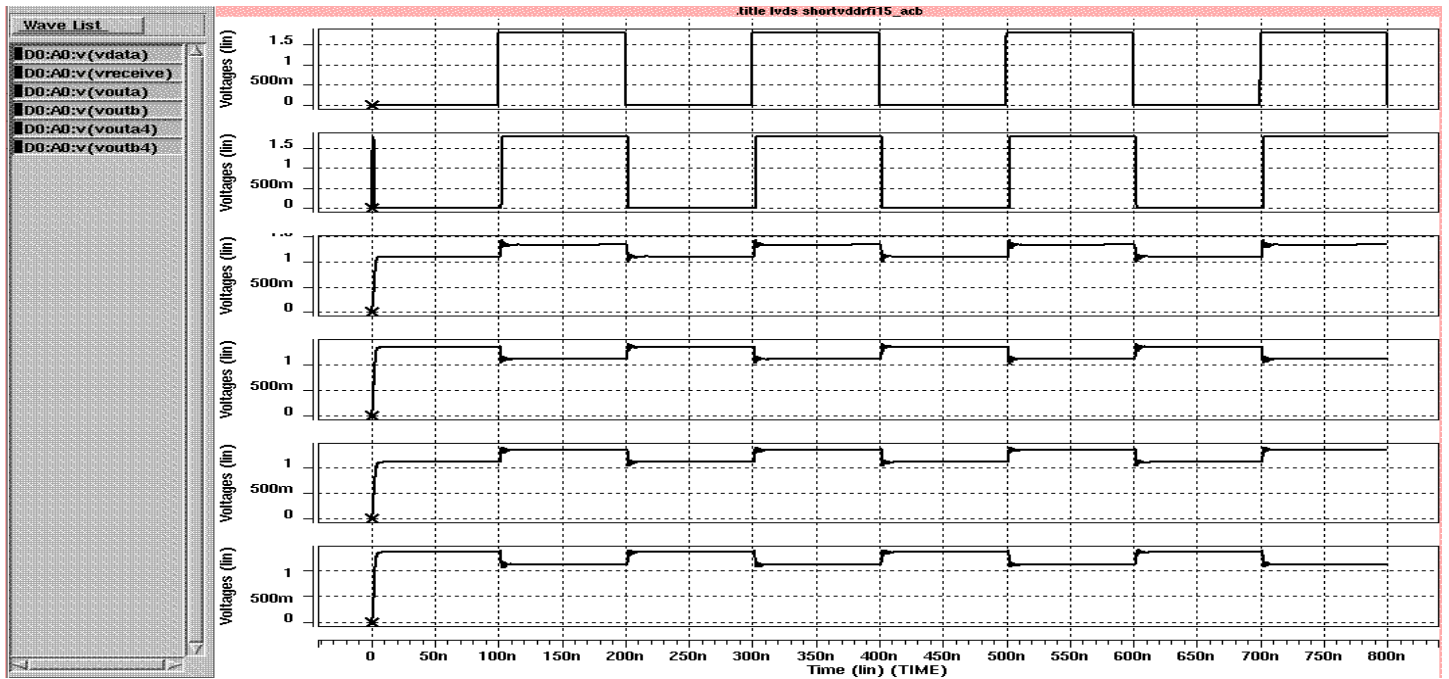

#### 3.17.2 Stuck to 2.5V: Detected

