

**BR060R01 (submitted for p1394.1 committee vote):
FirstRead/Write/Swap, FinalRead/Write/Swap, and
FlushRead/Write/Swap**

Dr. David V. James, Sony
3300 Zanker Road, MS SJ3C1
San Jose, CA 95134-4591
Phone: 408 955-6295
FAX: 408 955-4591
Email: dvj@alum.mit.edu

December, 1999

**This contribution is one of several, presented for review and incorporation.
An overall contribution, which provides an overall context for this and other contri-
butions, is presented in BR047R10.**

Special transactions are proposed for accessing first and final portals, on the path towards the destination.
An ordered FlushRead transaction is like a FialRead, but maintains ordering.

1.11 Special transactions

To support specialized operations between bus-bridge portals, several forms of extended block-write and block-read transactions are defined. These transactions, which are always processed by a portal (rather than an addressed node) include the following:

- FirstWrite. A block write transaction directed to the source's destination-path portal (see 1.11.1).
- FirstRead. A block read transaction directed to the source's destination-path portal (see 1.11.1).
- FirstSwap. A variant of FirstWrite, with a request-sized data payload.
- FinalWrite. A block write transaction directed to the destination's source-path portal (see 1.11.2).
- FinalRead. A block read transaction directed to the destination's source-path portal (see 1.11.2).
- FinalSwap. A variant of FinalWrite, with a request-sized data payload.

There is no explicit command for directed requests to a bus's alpha portal. Instead, the alpha portal responds to two addresses: $local_ID = 3F_{16}$ and $local_ID = phy_ID$ addresses.

Other remote-bus operations, such as the sourcing of GASP packets, can be activated by using a FinalWrite or FinalSwap transaction to direct a message to the bus's source-path portal. Other remote-bus commands, including bus-reset activation and remote phy-packet sourcing, can also be done in this fashion. See 1.11.2 for details.

1.11.1 FirstRead and FirstWrite transactions

FirstRead and FirstWrite requests are implicitly addressed to the source node's destination-side portal, as illustrated in figure 1. The *nodeID* of the responding portal are included in the response, for diagnostic purposes.

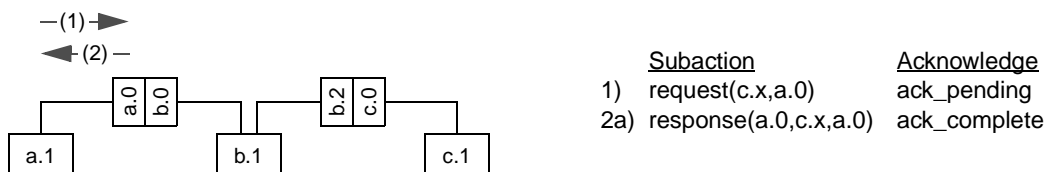

Figure 1—FirstRead and FirstWrite transaction sequences

1.11.2 FinalRead and FinalWrite transactions

FinalRead and **FinalWrite** requests are implicitly addressed to the destination node's source-side portal, as illustrated in figure 2. The nodeID of the responding portal is also contained in the response.

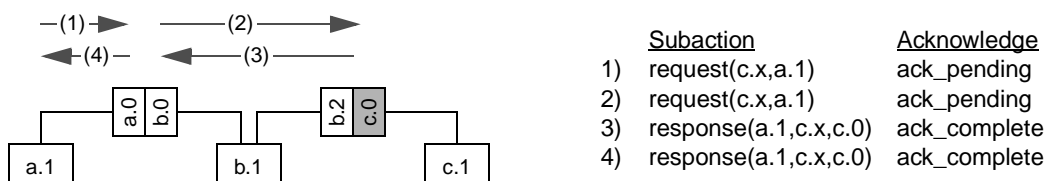

Figure 2—FinalRead and FinalWrite transactions

The **FlushRead** and **FlushWrite** transactions have the same format and function, but are constrained not to pass previously queued packets with the same *destination_ID/source_ID* addresses.

1.11.3 FinalGasp transactions

A remote GASP packet can be produced by encapsulating the isochronous quadlets (excluding the CRC) within the payload of a **FinalWrite** request. The payload of the FinalWrite becomes the contents of a GASP packet when the request reaches its final bus, as illustrated by figure 3.

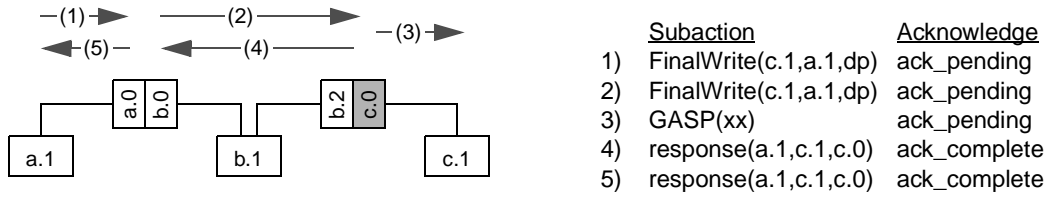

Figure 3—FinalGasp transaction sequence

A similar strategy can be used to send physical-layer-dependent phy packets to remote buses.

3. Subaction forwarding

3.1 Special transactions

To support specialized operations between bus-bridge portals, several forms of extended block-write and block-read transactions are defined. These transactions, which are always processed by a portal (rather than an addressed node) include the following:

- FirstWrite. A block write transaction directed to the source's destination-path portal (see 1.11.1).
- FirstRead. A block read transaction directed to the source's destination-path portal (see 1.11.1).
- FirstSwap. A variant of FirstWrite, with a request-sized data payload.
- FinalWrite. A block write transaction directed to the destination's source-path portal (see 1.11.2).
- FinalRead. A block read transaction directed to the destination's source-path portal (see 1.11.2).
- FinalSwap. A variant of FinalWrite, with a request-sized data payload.

There is no explicit command for directed requests to a bus's alpha portal. Instead, the alpha portal responds to two addresses: $\text{local_ID} = 3F_{16}$ and $\text{local_ID} = \text{phy_ID}$ addresses.

Other remote-bus operations, such as the sourcing of GASP packets, can be activated by using a FinalWrite or FinalSwap transaction to direct a message to the bus's source-path portal. Other remote-bus commands, including bus-reset activation and remote phy-packet sourcing, can also be done in this fashion. See 1.11.2 for details.

3.1.1 FirstRead and FirstWrite transactions

FirstRead and **FirstWrite** requests are implicitly addressed to the source node's destination-side portal, as illustrated in figure 4 and figure 5. The virtual *virtualID* of the responding portal is included in the response, for diagnostic purposes.

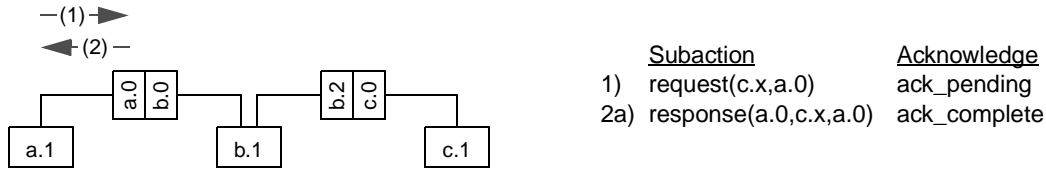

Figure 4—FirstRead and FirstWrite transaction sequences

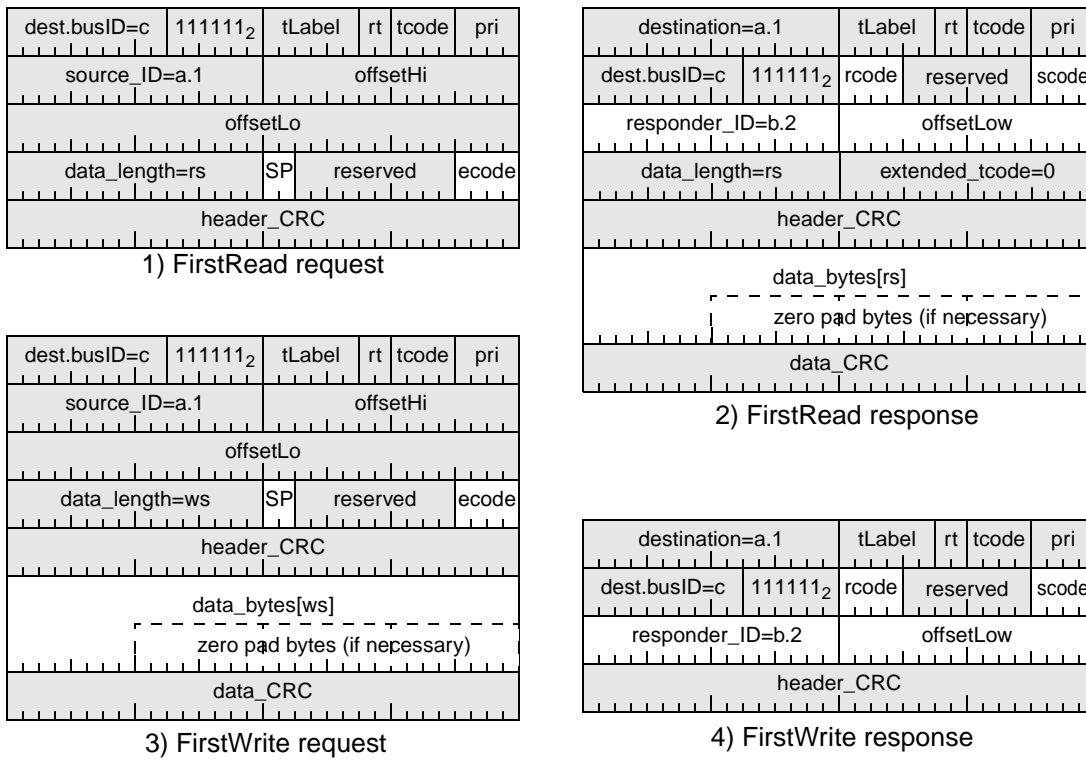

Figure 5—FirstRead and FirstWrite subactions

3.1.2 FinalRead and FinalWrite transactions

FinalRead and FinalWrite requests are implicitly addressed to the destination node's source-side portal, as illustrated in figure 6 and figure 7. The virtual nodeID of the responding portal is also contained in the response.

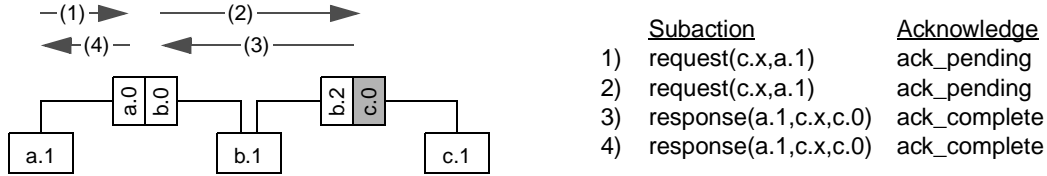

Figure 6—FinalRead and FinalWrite transactions

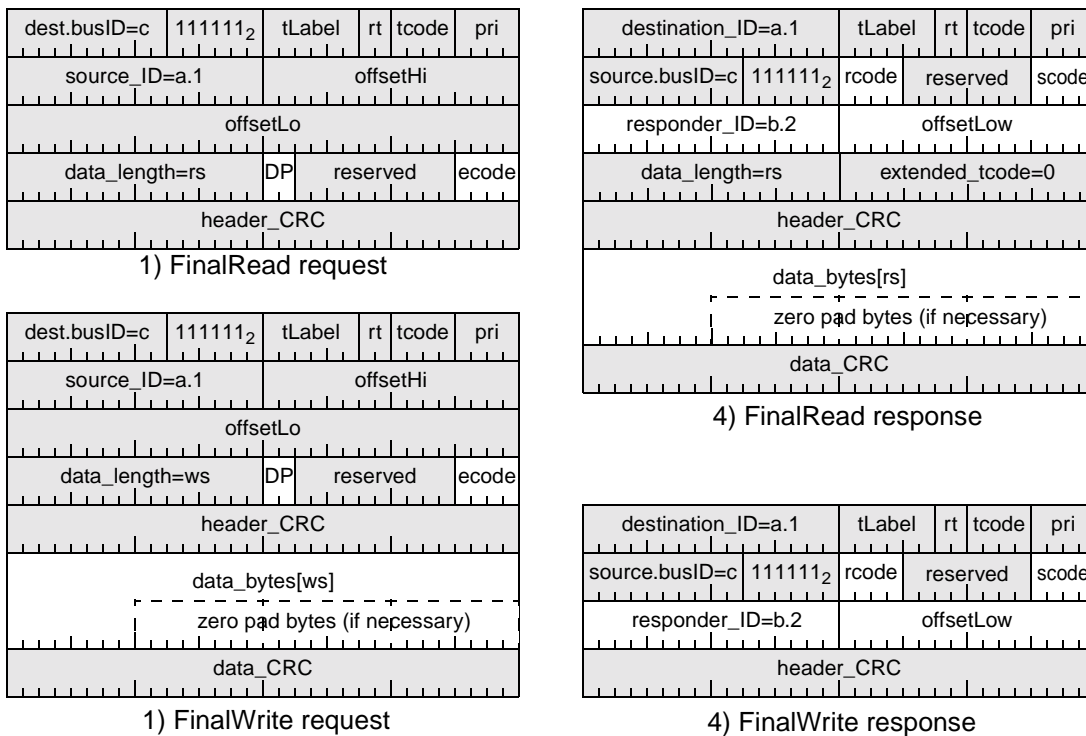

Figure 7—FinalRead and FinalWrite subactions

3.1.3 FirstSwap/FinalSwap transactions

The FirstSwap and FinaSwap transactions can also be directed to the source's destination-side portal, the destination's source-side portal, or the destination's alpha portal. Their formats are similar to the FirstWrite and FinalWrite transactions, as illustrated in figure 8.

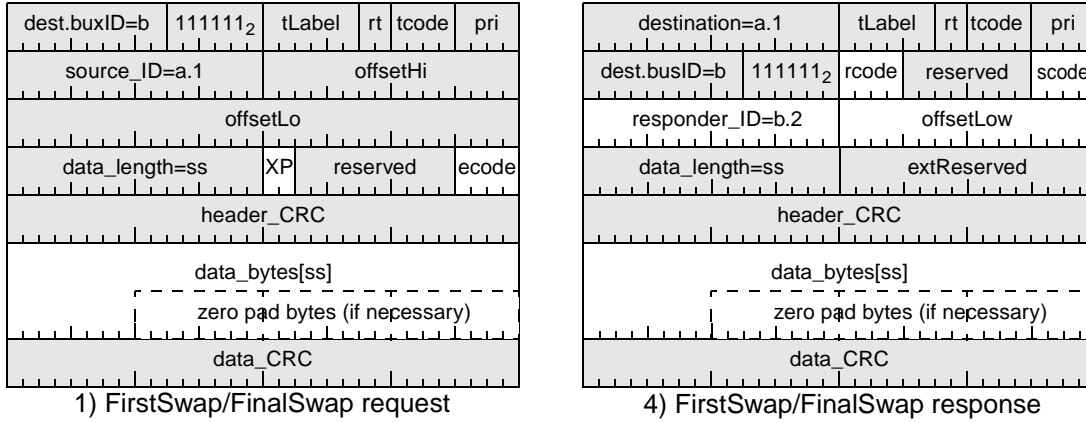

Figure 8—FirstSwap and FinalSwap subactions

3.1.4 FinalGasp transactions

A remote GASP packet can be produced by encapsulating the isochronous quadlets (excluding the CRC) within the payload of a FinalWrite request. The payload of the FinalWrite becomes the contents of a GASP packet when the request reaches its final bus, as illustrated by figure 9 and figure 10.

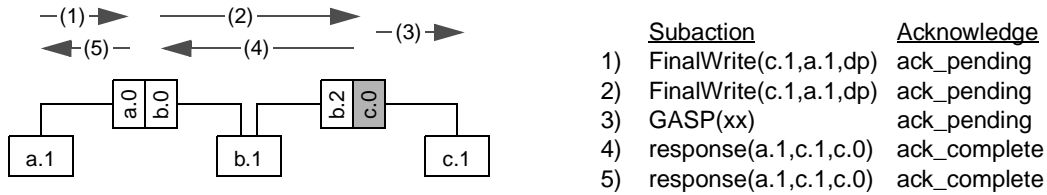

Figure 9—FinalGasp transaction sequence

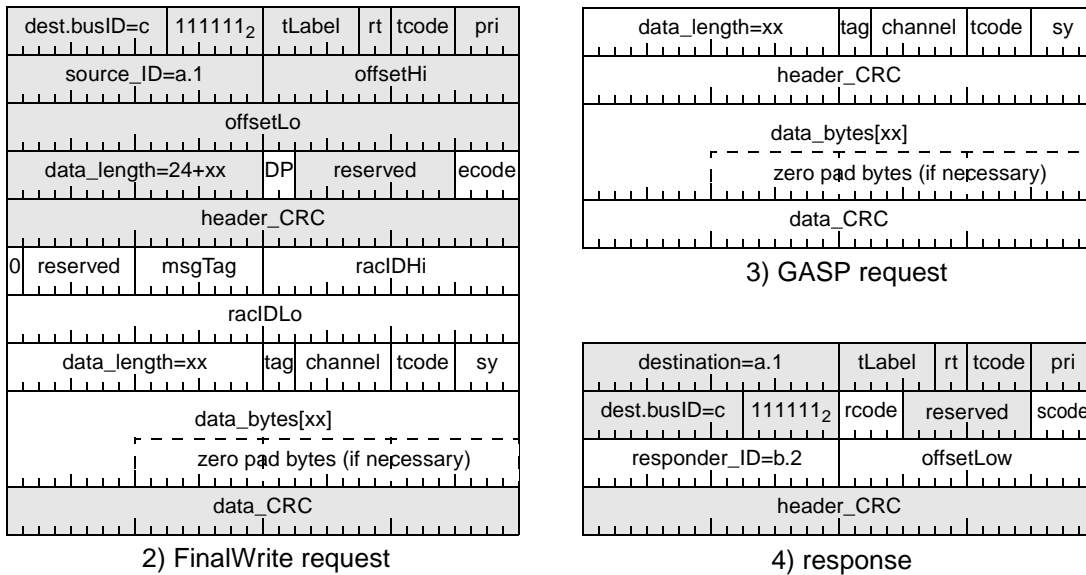

Figure 10—FinalGASP subactions

8. Packet formats

8.1 Path directed requests

8.1.1 FirstRead and FinalRead formats

The format of the **FirstRead** or **FinalRead** request is similar to the block-read request, as illustrated in figure 11. This request is directed to the broadcast phyID address (since the bridge portal is unknown) and contains distinctive extended_tcode values.

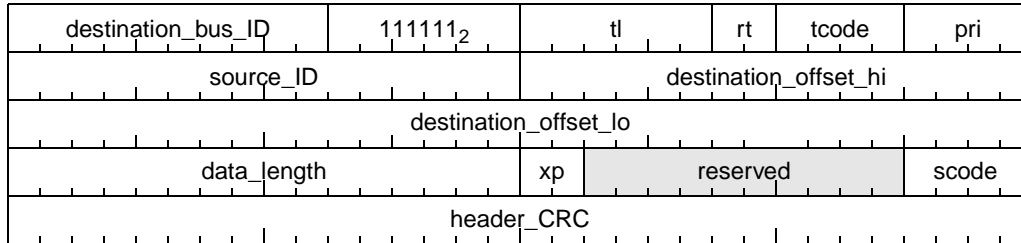

Figure 11—FirstRead/FinalRead request format

The 2-bit *xp* field differentiate between different portal addresses, as specified in table 1.

Table 1—*xp* field specifier

Value	Name	Description
0	NORM	Normal bridge-portal processing
1	FIRST	Taken by the source's destination-path portal
2	FINAL	Taken by the source's destination-path portal
3	FLUSH	Like FINAL, with ordering constraint

8.1.2 FirstWrite/FinalWrite and FirstSwap/FinalSwap formats

The format of the FirstWrite or FinalWrite request is similar to the block-write request, as illustrated in figure 12. This request is directed to the broadcast virtualID address (since the bridge portal is unknown) and contains an extended_tcode value of LOCAL.

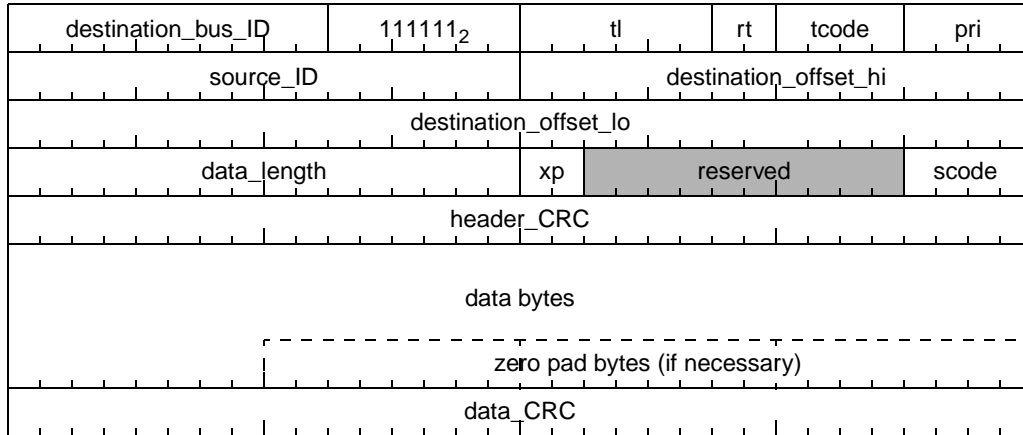

Figure 12—FirstWrite/FinalWrite & FirstSwap/FinalSwap formats

The 2-bit *xp* field is defined in 8.1.1. The *s* bit values identify FirstWrite/FinalWrite and FirstSwap/FinalSwap requests, for 0 and 1 values respectively.

