

# — Port task group (formerly “standard protocol”)

Alistair Coles	HP	<a href="mailto:anc@hplb.hpl.hp.com">anc@hplb.hpl.hp.com</a> (Task Group leader)
Lee Wilson	IBM	<a href="mailto:leewils@us.ibm.com">leewils@us.ibm.com</a>
Michael Johas Teener	Firefly	<a href="mailto:mike@fireflyinc.com">mike@fireflyinc.com</a>
Dave Instone	Xyratex	<a href="mailto:dinstone@uk.xyratex.com">dinstone@uk.xyratex.com</a>
Takayuki Nyu	NEC	<a href="mailto:new@optsys.cl.nec.co.jp">new@optsys.cl.nec.co.jp</a>
Yasuhiro Watanabe	Fujitsu	<a href="mailto:ywata@flab.fujitsu.co.jp">ywata@flab.fujitsu.co.jp</a>
Palanisamy Mohanraj	Intel	<a href="mailto:palanisamy_mohanraj@ccm.ch.intel.com">palanisamy_mohanraj@ccm.ch.intel.com</a>
Oleg Awsienko	Intel	<a href="mailto:oleg_awsienko@ccm.ch.intel.com">oleg_awsienko@ccm.ch.intel.com</a>
Dave LaFollette	Intel	<a href="mailto:dlafolle@mipos2.sc.intel.com">dlafolle@mipos2.sc.intel.com</a>
James Nave	TI	<a href="mailto:Jim_Nave@ti.com">Jim_Nave@ti.com</a>
Keith Heilman	IBM	<a href="mailto:kheilman@us.ibm.com">kheilman@us.ibm.com</a>
Michael Sorna	IBM	<a href="mailto:sorna@vnet.ibm.com">sorna@vnet.ibm.com</a>
Paul Levy	VLSI	<a href="mailto:paul.levy@vlsi.com">paul.levy@vlsi.com</a>
Jerry Hauck	Intel	<a href="mailto:jerry_hauck@ccm.sc.intel.com">jerry_hauck@ccm.sc.intel.com</a>
Colin Whitby-Strevens	SGS Thomson	<a href="mailto:colinws@bristol.st.com">colinws@bristol.st.com</a>
David Wooten	Compaq	<a href="mailto:david.wooten@compaq.com">david.wooten@compaq.com</a>

To join group:

email Alistair Coles: [anc@hplb.hpl.hp.com](mailto:anc@hplb.hpl.hp.com)

---

# — Mode of operation

---

- primarily email
- face-to-face when possible (1394b meetings)
- contributions solicited:
  - addressing open issues
  - text for draft
- once agreement is reached, generate proposed text for draft and publish on 1394B web site & reflector.

---

# — Scope includes:

- Define handling of arbitration and data signals through beta mode ports i.e. 'normal operation'.
- Equivalent to following 1394a functions:
  - tx\_bit
  - start\_tx\_packet
  - stop\_tx\_packet
  - decode\_bit
  - rx\_bit
  - start\_rx\_packet
  - stop\_rx\_packet
  - + functions to translate arbitration signals to 10-bit control words.
- Define handling of errors in received signals
  - notification of errored packets
  - exit 'normal operation' to Start-up
- Generate text, state machines, C-code, timing parameters.

---

# — Scope does not include:

- Tree ID (root contention resolution), self ID, normal arbitration, arbitration enhancements.
- Start up, re-training.
- DS-mode operation.
- Electrical parameters.

## Proposed Interfaces:

- Enhancements task group
  - *Port exchanges data bytes, control states (e.g. 'IDLE', 'TX\_REQUEST') and 'speed' values with Arbitration state machines.*
- Connectivity management task group
  - *Port exchanges control states (Table 7-1, Draft 0.05) with Connectivity Management.*
- Standard electrical task group
  - *Port exchanges tx and rx serial bitstream with electrical interface.*

# Proposed Model

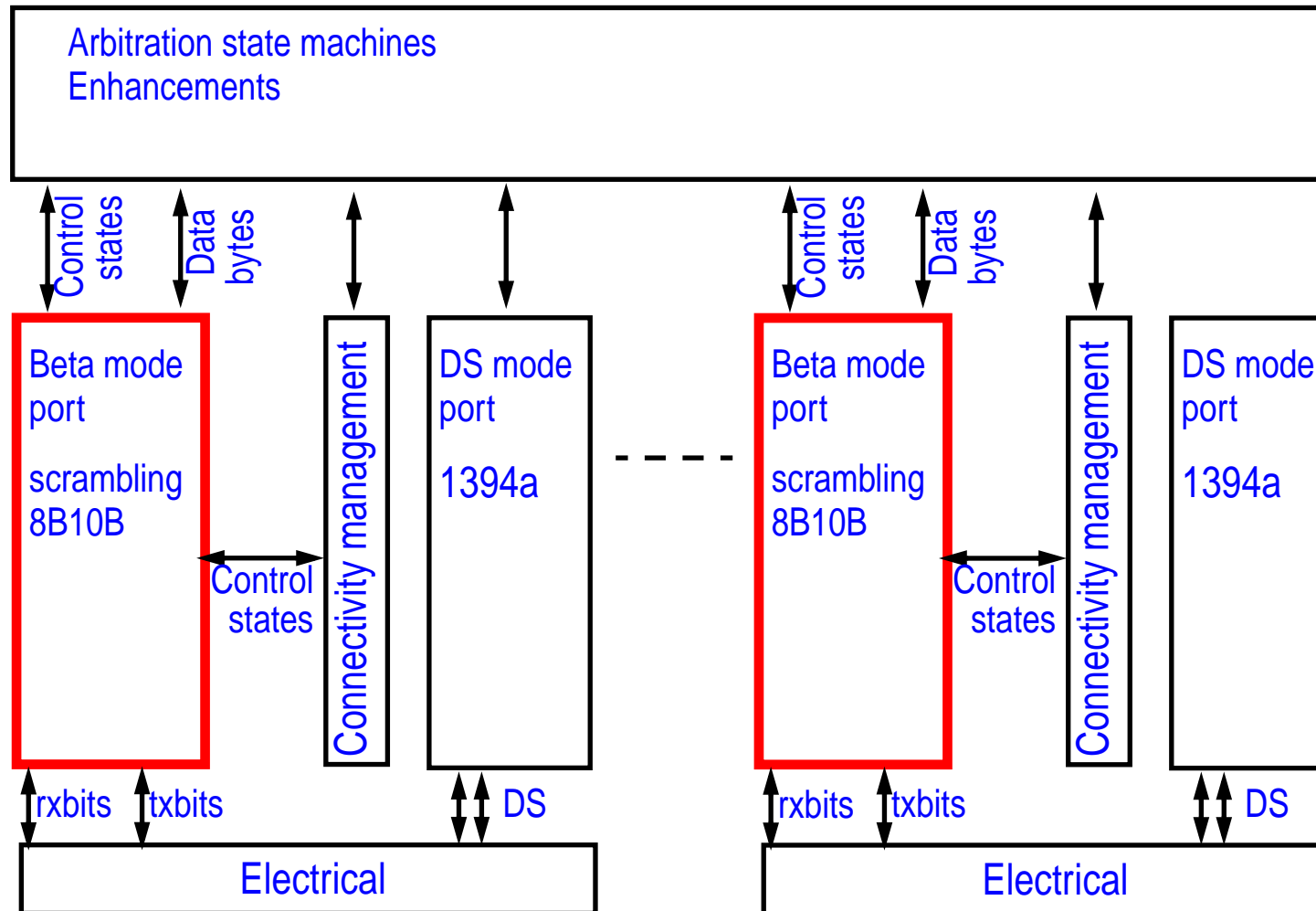

---

# Issues

---

- Speed signaling
  - proposal on web site - do we allow for revision of S200 to S400 ?
  
- Error reporting
  - how do errors detected during decoding get passed to Link layer for packet to be ignored?
  - how do errors detected during decoding get indicated on forwarded packet?
  
- Error handling
  - when do we abort normal operation and retrain the link? (input coming based on ESCON)