



P1394b Accelerations

Questions!

- Elasticity buffer size
 - » increased to insert request/grant?
 - » further increased for arb reset token?
- Efficiency
 - » Grant goes to link or child?
- Request timing
 - » when are they sent/cancelled?
- Fairness interval detection
 - » root detects and sends token?
 - » all nodes detect?
- Error handling
 - » what happens when tokens are lost?

Answers?

- Elasticity buffer size
 - » The elasticity buffer and latency do not need to be increased
 - » let bus owner / transmitting node act as root
 - » tokens are not embedded in packets
 - arbitration requests always flow on available reverse channel
 - requests always go toward the transmitting node
 - grant/deny follows packet and transfers grant ownership
 - grant is special case of DATA_END

More Answers?

- Efficiency
 - » request priority coding is possible with stream of requests
 - » grant goes to highest priority request
 - » In case of tie between link and child port, grant goes to link
 - minimizes idle time by starting packet at earliest time
 - » requests for next interval can be made with low priority
 - transition to next fairness interval can occur during continuous stream of concatenated packets!
- Request timing
 - » Requests are sent continually
 - » Requests are not cancelled, they are superseded by more requests
- Fairness interval detection
 - » supervising/transmitting node detects and sends token

More Answers?

- Error Handling

- » lost request
 - requests are sent continually
 - lost or corrupted request is superseded by following requests
- » lost grant
 - root reclaims bus ownership after timeout

Example

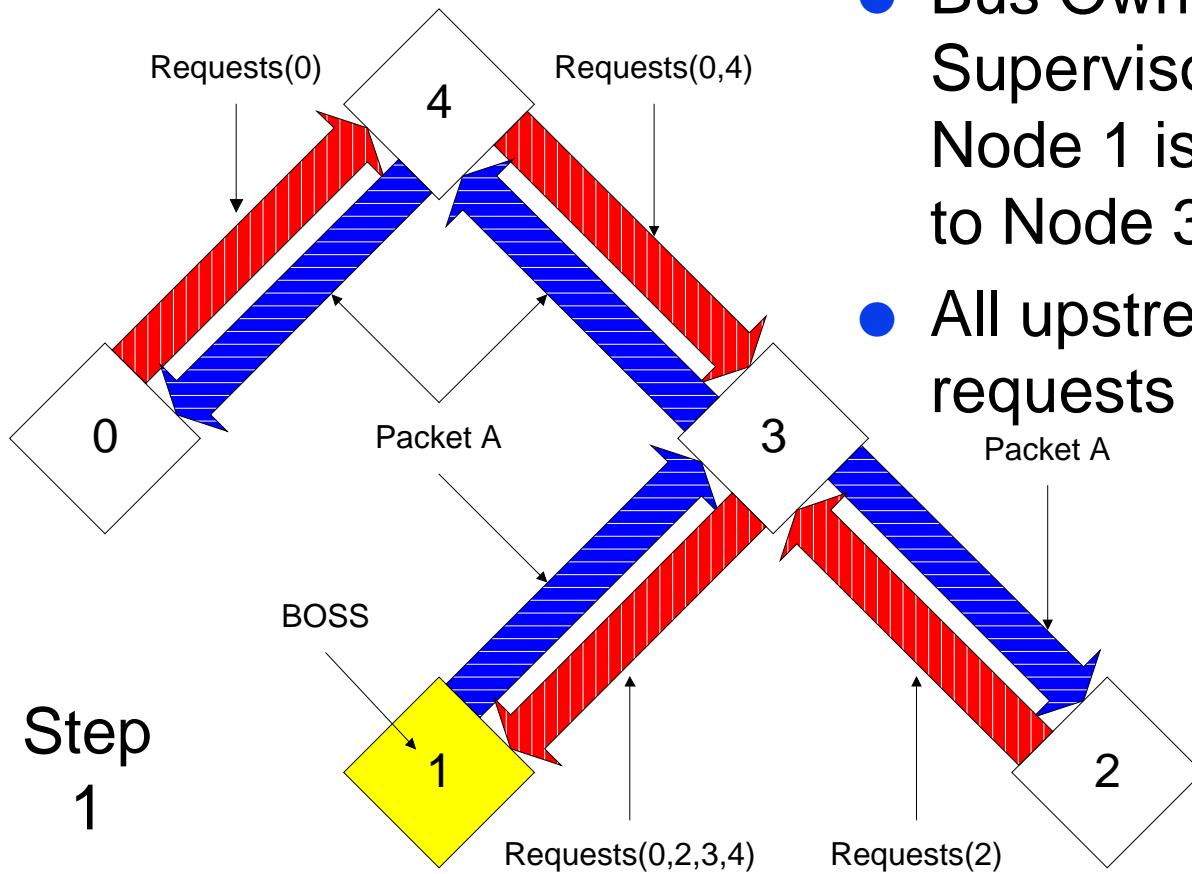

- Bus Owner/ Supervisor/Selector (BOSS) Node 1 is sending Packet A to Node 3
- All upstream paths contain requests to the BOSS

Example

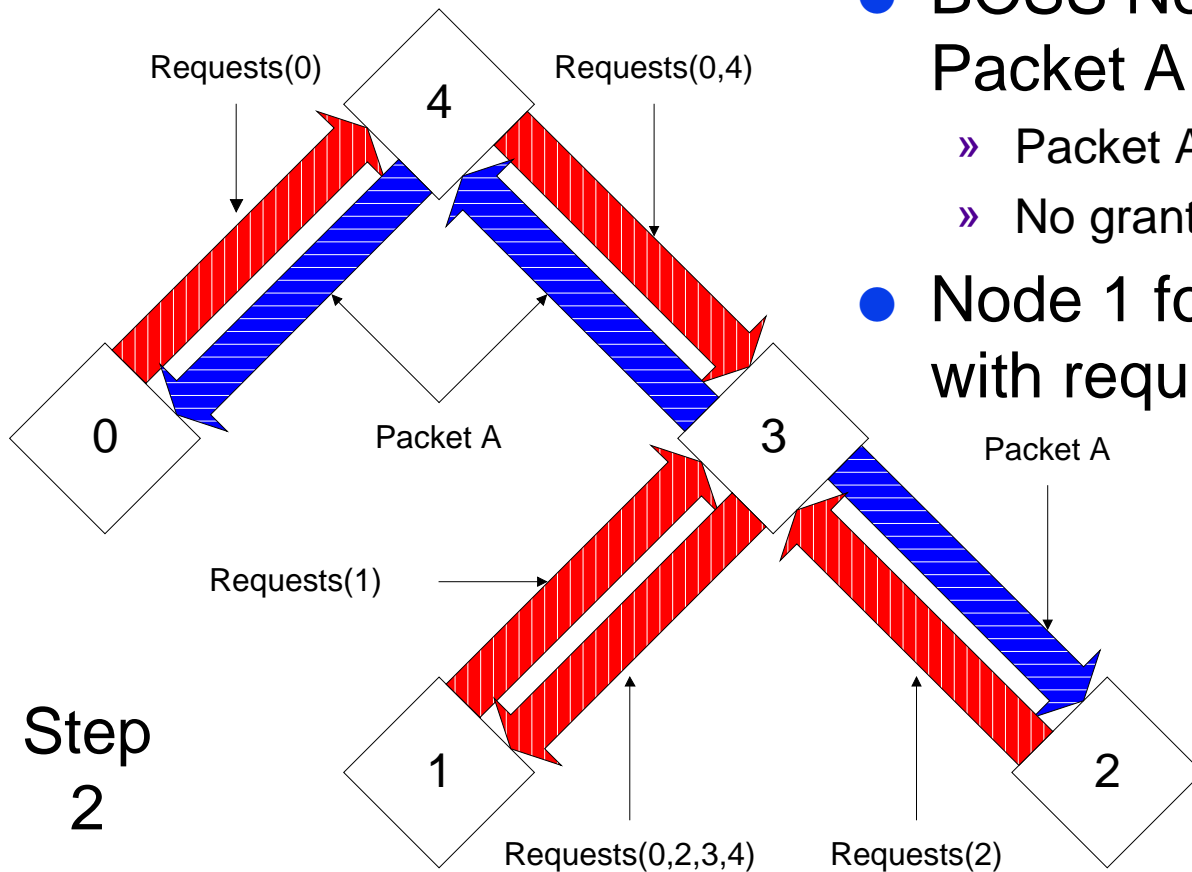

- BOSS Node 1 completes Packet A
 - » Packet A Requires an ACK
 - » No grant is sent
- Node 1 follows Packet A with requests

Example

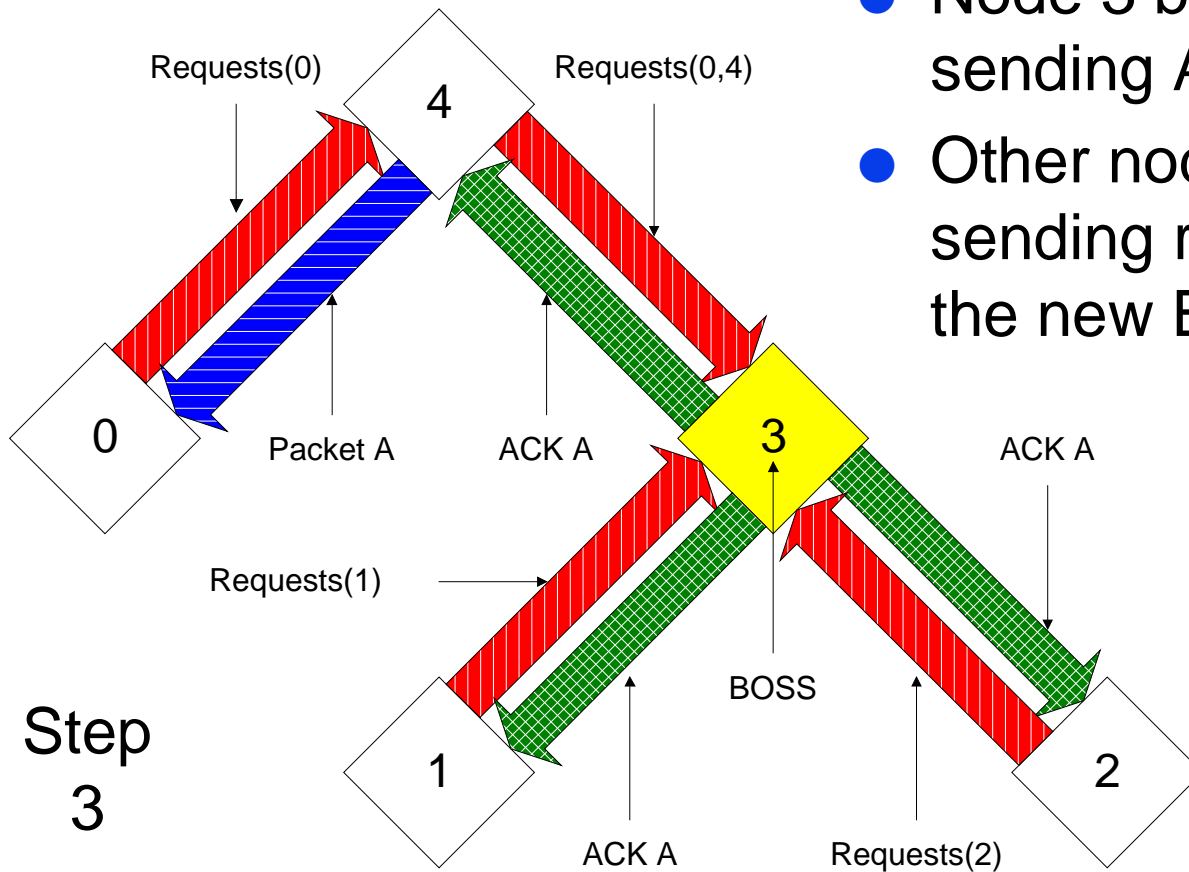

- Node 3 becomes BOSS by sending ACK
- Other nodes continue sending requests toward the new BOSS, Node 3

Step
3

Example

- Node 3 BOSS grants highest priority request
- sends requests on all ports

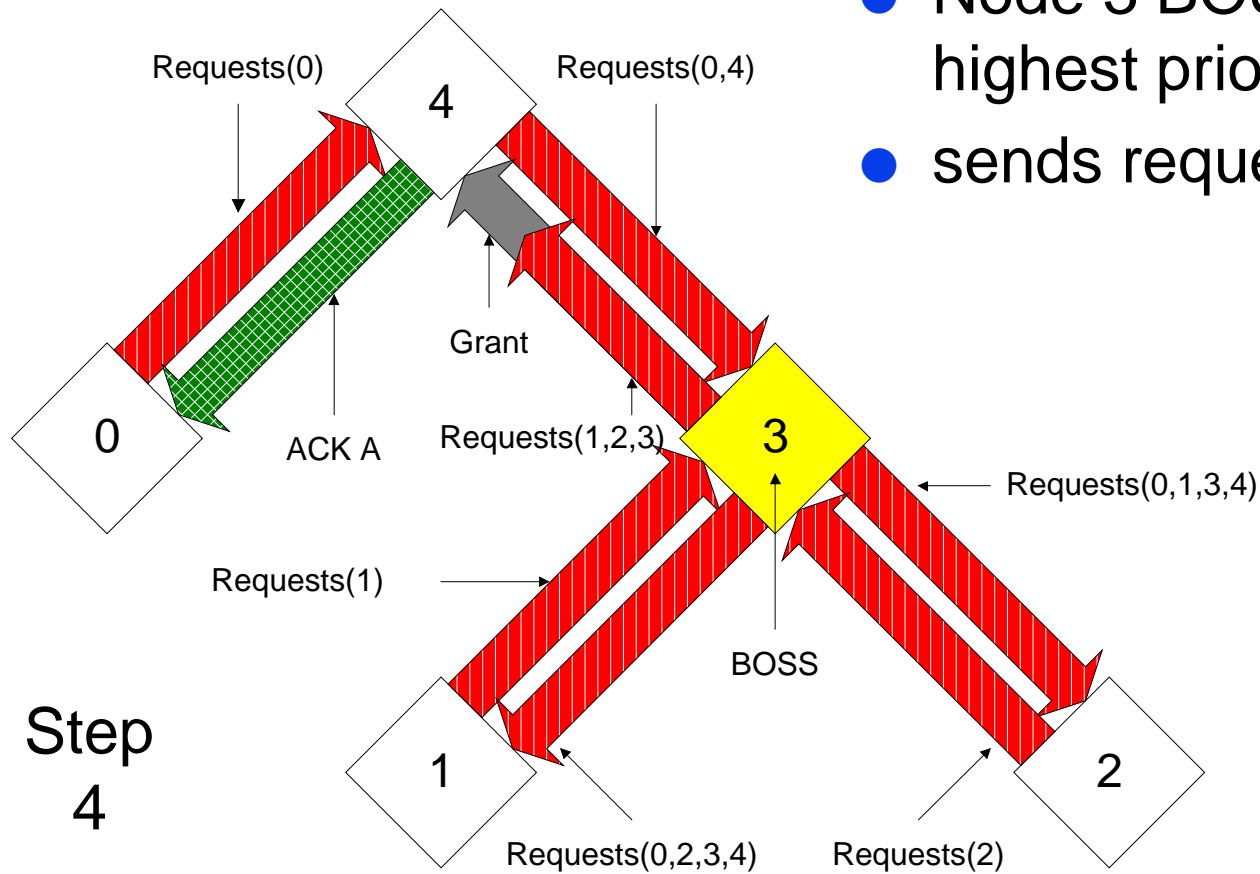

Example

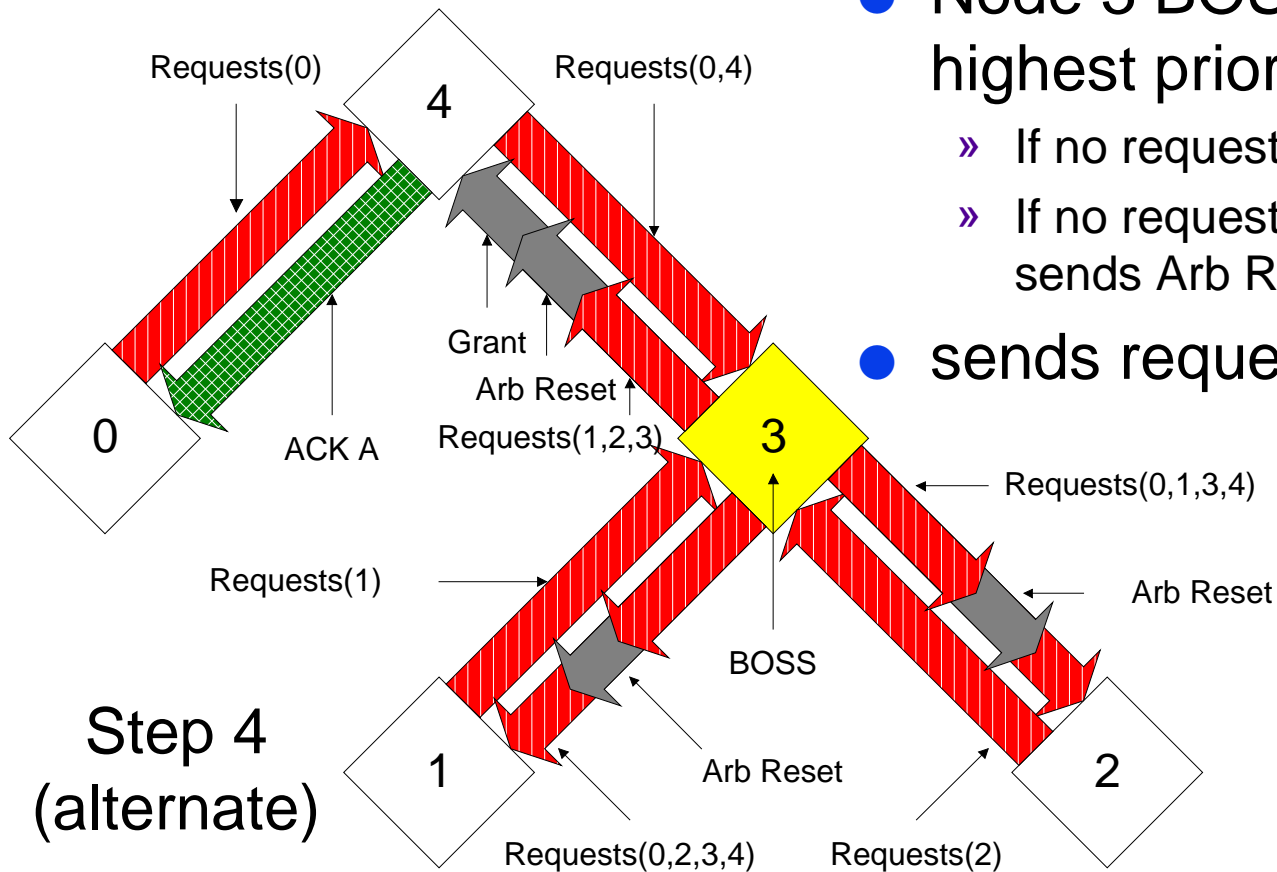

Step 4
(alternate)

- Node 3 BOSS grants highest priority request
 - » If no requests, grants parent
 - » If no requests for this interval, sends Arb Reset on all ports
- sends requests on all ports

Example

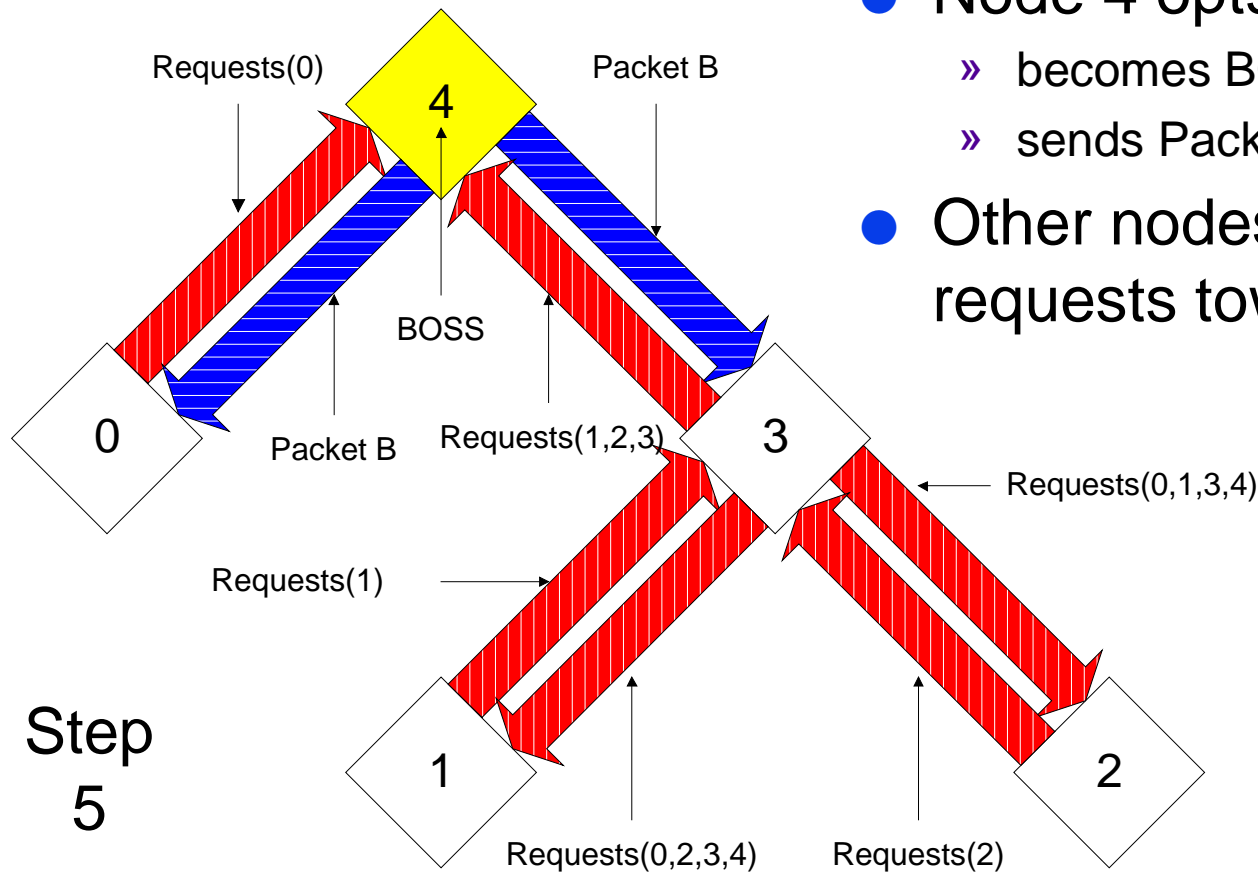

- Node 4 opts to claim grant
 - » becomes BOSS
 - » sends Packet B
- Other nodes forward requests toward BOSS

Benefits

- Minimum elasticity buffer
 - » space is not needed to insert tokens within the data stream
 - » request size can increase
 - Use request token followed by 8 bit request/arb reset data?
 - Requests can contain priorities
 - cycle start > current isoch > next isoch > current asynch > next asynch
- Arbitration phase eliminated (concurrent with data)
- Subaction gap eliminated
- Arb reset gap eliminated
- Optimal concatenation
 - » node closer to sender are favored, idle time is reduced
 - » any granted node may concatenate
 - In 1394A, the possible path for concatenation is between the sender and the root

More Benefits

- Continuous stream of requests
 - » requests are generally available at the node issuing the grant when the node is ready to send the grant
 - » continuously updated priority can be included in requests
- Error handling
 - » lost request
 - requests are sent continually
 - » lost grant
 - grant is passed to parent port if no requests pending
 - root always receives a packet or a grant
 - timeout occurs when the root receives neither a packet nor a grant
 - root becomes the BOSS after bus reset or upon timeout