

## 9. Alternative low cost, long distance physical media dependent layer-- CAT5 UTP

### 9. Category 5 UTP physical medium dependent layer

The alternative ~~low cost~~ long distance physical layer specified by this section (~~CAT 5 UTP~~) enables signaling over ~~50m of~~ Category 5 Unshielded Twisted Pair (UTP) cable while keeping interoperability with the IEEE P1394b interface at a data rate of 100Mbps.

#### 9.1 Overview

This clause specifies the physical media dependent (PMD) sublayer of CAT-5 UTP links for the data rate of 100Mbps. ~~This PMD provides a digital baseband point-to-point interconnection among IEEE P1394b equipment for a distance extension over 50m, which meets the requirements for a IEEE P1394b long distance link.~~ The PMD provides all of the services required to transport a suitably coded digital bit stream across the link segment.

Two variations of this PMD are specified, supporting maximum cable reaches of 50m and 100m. The transmit specifications are common to both variations. Differences occur in the requirements for the receiver performance. It is envisaged that these two variations of the PMD will allow implementation at different cost points and support different market segments.

The PMD sublayer specified in this clause has the following general characteristics:

- Provides full duplex line transmission of P1394b beta mode packets at 125 MBaud
- Supports operation over at least 50 meters of Category 5 cabling (50m variation)  
or
- Supports operation over at least ~~50-100~~ meters of Category 5 ~~cabling~~cabling (100m variation)
- Bit Error Rate of less than or equal to  $10^{-10}$

#### 9.2 Glossary of Terms

- a) BER - Bit Error Ratio
- b) UTP - Unshielded Twisted Pair
- c) CAT-5 - Category 5 cabling

#### 9.3 PMD block diagram

For purposes of system conformance, the PMD sublayer is standardized at the following points. The CAT 5 UTP PMD transmitter characteristics are specified at the media connector (TP2) as shown in figure 9-1. The received signal characteristics are specified at the output of the cable plant (TP3). The specifications assume that all measurements are made after a mated connector pair, relative to the source or destination.

TP1 and TP4 are reference points for use by ~~implementers~~implementors to specify vendor components. TP1 and TP4 are used as reference points in this standard only in informative sections, as they may not be readily testable in a system implementation.

Figure 9-1—CAT 5 UTP PMD Interfaces

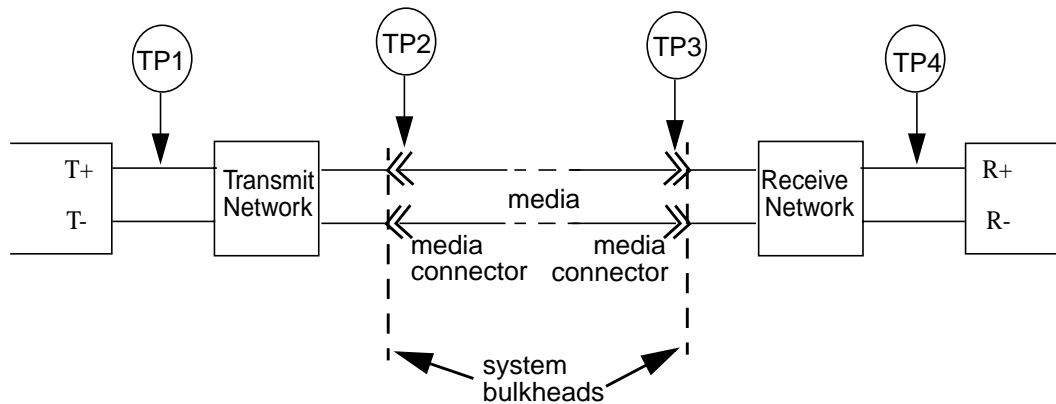

**9.4 PMD implementation (informative)**

The CAT 5 UTP PMD is specified in a manner that permits a simple implementation involving the addition of only passive components to a 1394B PHY device that provides the standard electrical interface specified in clause 5. However, implementation in this manner is not a requirement of this standard and is described here for informative purposes only.

A typical implementation may consist of a 1394B PHY device attached to the media via a transmit network and media connector. It is envisaged that such a transmit network could be a passive circuit that adjusts the transmit voltage of the standard electrical interface at TP1 to the levels specified for the UTP media at TP2. The transmit network would typically include an isolating transformer.

The receive network would likewise typically include an isolating transformer. In addition, the receive network would include an equalization network that corrects for the frequency dependent attenuation of the cable plant. A typical equalization circuit is described in [tbd].

**9.5 Operation of CAT-5 links**

P1394b CAT-5 links employ full-duplex baseband transmission over two pairs of Category 5 Unshielded twisted-pair wiring. The signals are NRZ binary symbols sent at 125 MBaud according to the standard P1394b symbol encodings. Connection between the CAT 5 cable system and the P1394b PHY I/O pads may be accomplished by means of pulse transformers which ensure impedance matching and fully differential signal launch/reception over the useful spectrum of the bit stream.

**9.6 Media specification**

The UTP link may consist of cable, end connectors and intermediate connection devices such as patch panels and wall plates.

**9.6.1 100 ohm UTP link segment ~~specification~~specification - 50m reach**

All components of a link segment shall meet the requirements specified by ISO/IEC 11801 for category 5 compliance. In addition, the link shall meet the requirements specified by ISO/IEC 11801 chapter 7 for a 100 ohm balanced class D link, adjusted for a maximum channel length of 50m. This adjustment shall be made by subtracting the maximum permitted attenuation of 50m of category 5 100 ohm balanced UTP from the maximum attenuation value. This implies that the maximum attenuation at 62.5 MHz is 9.85 dB.

A link segment containing a combination of no more than 40m of category 5 UTP, no more than 10m of category 5 flexible cord and no more than four category 5 connectors is compliant with this specification.

**9.6.2 100 ohm UTP link segment specification - 100m reach**

All components of a link segment shall meet the requirements specified by ISO/IEC 11801 for category 5 compliance. In addition, the link shall meet the requirements specified by ISO/IEC 11801 chapter 7 for a 100 ohm balanced class D link. A link segment containing a combination of no more than 90m of category 5 UTP, no more than 10m of category 5 flexible cord and no more than four category 5 connectors is compliant with this specification.

**9.6.3 100 ohm UTP cable specification**

The transmission medium for a UTP PMD channel shall be two pair or four pair 100 ohm balanced UTP meeting all the requirements for 100 ohm balanced category 5 cables specified by ISO/IEC 11801:1995 chapter 8.

**9.6.4 Connection hardware**

All connecting hardware used within a UTP PMD channel (including outlets, transition ~~connectors~~connectors, patch panels and cross connect fields) shall meet or exceed the requirements specified in chapter 9 of ISO/IEC 11801 for category 5 100 ohm balanced cabling.

The procedures described in Annex A.2 of ISO/IEC 11801 shall be used to make all measurements verifying the compliance of connection hardware. The connector termination practices and UTP cable practices described in chapter 10 of EIA/TIA-568-A shall be followed.

**9.6.5 Media Interface Connector**

An eight pin receptacle (jack), meeting the requirements of IEC 603-7, shall be used as the mechanical interface between the PMD and the UTP link segment. ~~Figure [tbd]~~ Figure 9-2 and ~~table [tbd]~~ table 9-1 describe the pin assignment that shall be used for this connector

The link segment shall be terminated at each end with an eight pin plug, meeting the requirements of IEC 603-7. The link segment shall include a crossover function. The crossover shall connect pins 1 and 2 of the media interface connector at one end of a link segment to pins 7 and 8 respectively at the other end of the link segment. The fashion in which this crossover is implemented (for example, within a patchcord or within connection hardware) is beyond the scope of this standard.

**Figure 9-2—Media Interface Connector**

**Table 9-1—Media Interface Connector pin assignments**

Pin	Circuit
1	Tx+
2	Tx-

1  
2  
3  
4  
5  
6  
7  
8  
9  
10  
11  
12  
13  
14  
15  
16  
17  
18  
19  
20  
21  
22  
23  
24  
25  
26  
27  
28  
29  
30  
31  
32  
33  
34  
35  
36  
37  
38  
39  
40  
41  
42  
43  
44  
45  
46  
47  
48  
49  
50  
51  
52  
53  
54  
55  
56  
57  
58  
59  
60  
61  
62  
63  
64  
65  
66

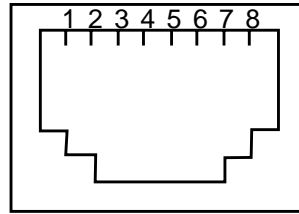

**Table 9-1—Media Interface Connector pin assignments**

Pin	Circuit
3	
4	
5	
6	
7	Rx+
8	Rx-

**9.7 PMD electrical specifications**

**9.7.1 Galvanic isolation**

A coupling transformer is normally used within a UTP PMD to electrically isolate the 1394b PHY and the UTP cable plant. The UTP PMD shall provide electrical isolation according to at least one of the following electrical strength tests:

- a) 1500 V rms at 50 Hz to 60 Hz for 60 seconds, applied as specified in Section 5.3.2 of IEC Publication 950.
- b) 2250 Vdc for 60 seconds, applied as specified in Section 5.3.2 of IEC Publication 950.
- c) A sequence of ten 2400 V impulses of alternating polarity, applied at intervals of not less than 1 second. The shape of the impulses shall be 1.2/50 ms (1.2 ms virtual front time, 50 ms virtual time or half value) as defined in IEC Publication 60.

There shall be no insulation breakdown, as defined in Section 5.3.2 of IEC Publication 950, during the test. The resistance after the test shall be at least 2 Megaohms, measured at 500 Vdc.

**9.7.2 Transmitter specifications**

The signal measured at the output of the UTP PMD media interface connector shall meet the requirements of table 9-2.

*Provisional:* In addition, the signal shall satisfy the requirements of the signal mask shown in figure 9-3 and calibrated in table 9-3. These specifications shall be met while the PMD is transmitting a continuously repeating D0.0 character. This character contains a sequence of three consecutive 1 symbols. This sequence of three 1's shall be compared with the signal mask shown in figure 3.

NOTE—A sequence of repeating D0.0 characters is generated whenever the port has its transmit scrambler disabled and is generating a REQ(training) signal.

**Table 9-2—UTP transmitter electrical specifications**

Parameter	Requirement	Units
Differential amplitude  (peak to peak)		
Max	7631050	mV
Min	540950	mV
Max(OFF)	162	mV
Rise/fall time		
Max	tbd 5?	ns
Min	tbd 3?	ns
Differential skew	200	ps
Jitter	tbd	ps
Output balance		
0.1-30MHz	>45	dB
30-60MHz	>40	dB
60-100MHz	>35	dB
Return loss	tbd	dB

**Figure 9-3—Signal -mask for transmitted signal.**

**Table 9-3—Coordinates for signal mask**

X label	X value	Y label	Y value
X1	tbd	Y1	tbd
X2	tbd	Y2	tbd
X3	tbd	Y3	tbd
X4	tbd	Y4	tbd
X5	tbd	Y5	tbd
X6	tbd		

~~NOTE 1—The transmitter differential amplitude specification may be met by a transmitter compliant with table [tbd] coupled through a transformer having a turns ratio of  $\sqrt{\frac{110}{100}}$  and an insertion loss of 1 dB.~~

NOTE 1—~~Whilst~~ While this specification is intended to enable compliance with regulations concerning RF emissions, it is not intended to ensure compliance with these regulations. The implementor should consider any applicable local, national or international regulations.

NOTE 2—Output balance is defined as the ratio of differential voltage to common mode voltage at the output of the transmitter.

NOTE 3—(Editorial) The provisional rise and fall time specification numbers are drawn from the FDDI TP-PMD standard.

1  
2  
3  
4  
5  
6  
7  
8  
9  
10  
11  
12  
13  
14  
15  
16  
17  
18  
19  
20  
21  
22  
23  
24  
25  
26  
27  
28  
29  
30  
31  
32  
33  
34  
35  
36  
37  
38  
39  
40  
41  
42  
43  
44  
45  
46  
47  
48  
49  
50  
51  
52  
53  
54  
55  
56  
57  
58  
59  
60  
61  
62  
63  
64  
65  
66

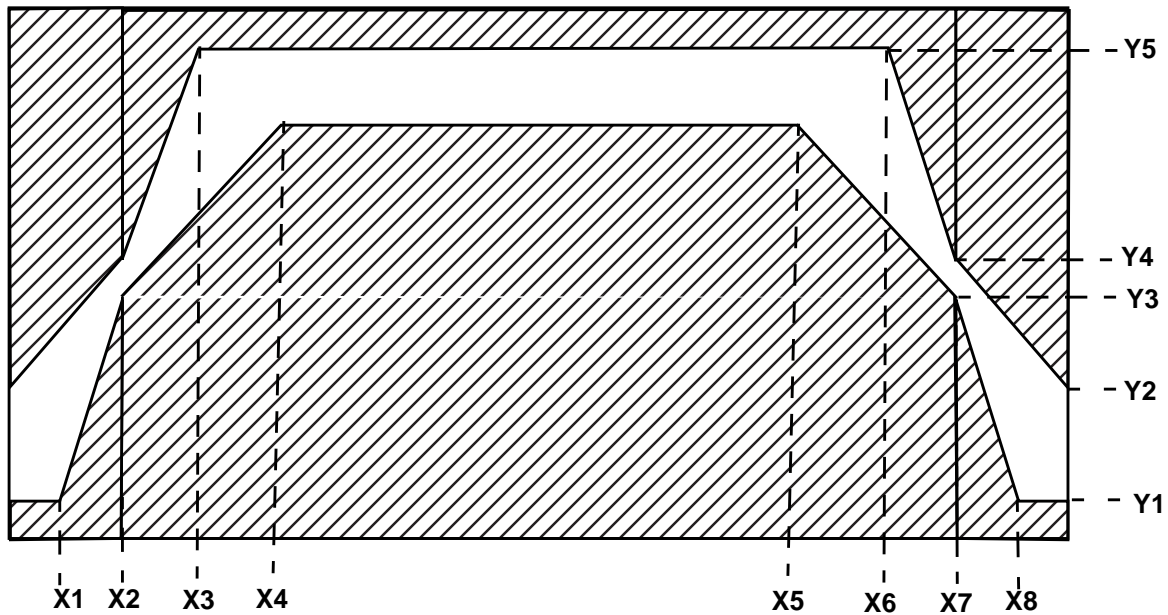

**9.7.3 Receiver specifications**

**9.7.3.1 Receiver input signals**

**9.7.3.2 Receiver input signals - 50m reach**

A UTP PMD receiver meeting the requirements for a 50m cable reach shall be capable of recovering data with a Bit Error Rate of better than or equal to  $1$  in  $10^{10}$  when receiving signals from the output of a worst case link segment. The worst case link segment shall consist of an appropriate length of cable and number of connectors, such that the link attenuation is equivalent to that specified by ISO/IEC 11801 chapter 7 for a 100 ohm balanced class D link, adjusted for a maximum channel length of 50m. This adjustment shall be made by subtracting the maximum permitted attenuation of 50m of category 5 100 ohm balanced UTP from the maximum attenuation value. This implies that the maximum attenuation at 62.5 MHz is 9.85 dB.

The receiver shall also be capable of recovering data with a Bit Error Rate of better than or equal to  $1$  in  $10^{10}$  when receiving signals from the output of a link segment comprising any length of category 5 UTP cable up to 50m, and any number of connectors up to a maximum of 4.

In addition to this, the receiver shall comply with the requirements of table 9-4.

**Table 9-4—UTP receiver electrical specifications**

Parameter	Requirement	Units
Minimum differential sensitivity	50	mV
Input impedance	100 +/- 15	ohm
Return loss:		
2MHz-30MHz	>16	dB
30MHz-60MHz	>16-20*log(f/30), f is frequency in MHz	dB
60MHz-100MHz	>10	dB

**9.7.3.3 Receiver input signals - 100m reach**

A UTP PMD receiver meeting the requirements for a 100m cable reach shall be capable of recovering data with a Bit Error Rate of better than or equal to 1 in 10<sup>10</sup> when receiving signals from the output of a worst case link segment. ~~The link segment shall consist of an appropriate length of cable and number of connectors, such that the link attenuation worst case link segment shall consist of an appropriate length of cable and number of connectors, such that the link attenuation~~ is equivalent to ~~the sum of the maximum attenuation specified in that specified by ISO/IEC 11801 chapter 8-7 for 50m of category 5 UTP and the maximum attenuation specified in ISO/IEC 11801 chapter 9 for four category 5 connectors~~ a 100 ohm balanced class D link.

The receiver shall also be capable of recovering data with a Bit Error Rate of better than or equal to 1 in 10<sup>10</sup> when receiving signals from the output of a link segment comprising any length of category 5 UTP cable up to ~~50m~~ 100m, and any number of connectors up to a maximum of 4.

In addition to this, the receiver shall comply with the requirements of ~~table [tbd]~~ table 9-4.

**Table 9-5—UTP receiver electrical specifications**

Parameter	Requirement	Units
Minimum differential sensitivity	50	mV
Input impedance	100 +/- 15	ohm
Return loss:		
2MHz-30MHz	>16	dB
30MHz-60MHz	>16-20*log(f/30), f is frequency in MHz	dB
60MHz-100MHz	>10	dB

**9.7.3.4 Receiver equalization (informative)**

**9.8 PMD implementation - 50m reach (informative)**

The CAT 5 UTP PMD is specified for 50m reach in a manner that permits a simple implementation involving the addition of only passive components to a 1394B PHY device that provides the standard electrical interface specified in clause 5. However, implementation in this manner is not a requirement of this standard and is described here for informative purposes only.

A typical implementation may consist of a 1394B PHY device attached to the media via a transmit network and media connector. It is envisaged that such a transmit network could be a passive circuit that adjusts the transmit voltage of the standard electrical interface at TP1 to the levels specified for the UTP media at TP2. The transmit network would typically include an isolating transformer.

The receive network would likewise typically include an isolating transformer. In ~~order to comply with the requirements of 9.7.3.2~~ addition, in order to comply with the requirements of 9.7.3.2 , it ~~is~~ may be necessary for the receiver to compensate for the distortion introduced to the signal due to the frequency dependent attenuation of the cable plant. This compensation is typically provided by an equalization circuit. This clause describes one implementation of an equalizer that might be suitable for use in a CAT 5 PMD. However, this method of implementation is not a requirement of this standard, and other equalization techniques are not prohibited. Furthermore, adoption of the equalization technique described in this subclause does not guarantee compliance with the standard; the implementor should also ensure that all the requirements of clause 9.7.3.2 are met.

The length of cable used between a CAT 5 PMD transmitter and receiver may vary from close to zero to fifty ~~metres~~ me-  
ters. The frequency response and level of distortion introduced by the cable plant may therefore vary from one cable plant to another. An adaptive equalizer reacts varying cable lengths by changing its frequency response to match the actual

1 cable length. In contrast, a fixed or compromise equalizer has a static frequency response that will not match all cable  
2 lengths. Fixed equalizers have the advantages of not requiring a training algorithm, and the potential for implementation  
3 using only passive components.  
4

5 A fixed equalizer can be used to provide sufficient equalization for a 1394B CAT 5 cable. An example of an equalizer circuit  
6 that may be used is shown in [figure 9-4](#). This circuit is a simple high pass filter that boosts the higher frequency  
7 components of the CAT 5 PMD in order to generate a sufficient decision window in the eye diagram at the output of the  
8 receive network (TP4). Examples of eye diagrams at the input [and output](#) and [output](#) of this equalizer circuit are shown in  
9 [figure 9-5](#).

Figure 9-4—Example equalizer circuit (informative)

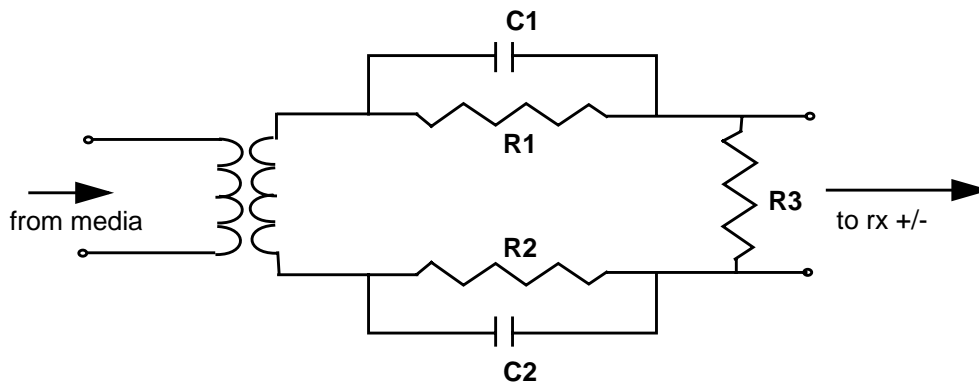

$R1 = R2 = \text{tbd}, C1 = C2 = \text{tbd}, R3 = \text{tbd}$

Figure 9-5—Signals at input and output of equalizer (informative)

TBD

### 9.9 PMD implementation - 100m reach (informative)

The CAT 5 UTP PMD for 100m reach has a specification that is similar to those contained in other standards documents supporting 100m of category 5 UTP, such as ANSI X3.263-1995 (Fibre Distributed Data Interface - Token Ring Twisted Pair Physical Layer Medium Dependent (TP-PMD)) and AF-PHY-0015.000 (ATM Physical Medium Dependent Interface Specification for 155Mb/s over Twisted Pair Cable). While the CAT 5 UTP PMD is compatible with all the logical functions of the 1394B PHY (e.g. 8B10B coding, scrambling), implementation of the 100m reach CAT 5 UTP PMD is likely to require further active components (e.g. line drivers, equalizer circuits) in addition to a 1394B PHY device that provides the standard electrical interface specified in clause 5. In this respect, it is envisaged that the CAT 5 UTP PMD for 100m reach may be implemented using technology similar to that developed for the standards referenced above. However, use of such technology is neither necessary not sufficient for compliance with this standard.

1 **9.10 Testing**

2  
3  
4 TBD -- various cable, transmitter and receiver test modes and templates.  
5  
6  
7  
8  
9  
10  
11  
12  
13  
14  
15  
16  
17  
18  
19  
20  
21  
22  
23  
24  
25  
26  
27  
28  
29  
30  
31  
31  
32  
33  
34  
35  
36  
37  
38  
39  
40  
41  
42  
43  
44  
45  
46  
47  
48  
49  
50  
51  
52  
53  
54  
55  
56  
57  
58  
59  
60  
61  
62  
63  
64  
65  
66

1  
2  
3  
4  
5  
6  
7  
8  
9  
10  
11  
12  
13  
14  
15  
16  
17  
18  
19  
20  
21  
22  
23  
24  
25  
26  
27  
28  
29  
30  
31  
31  
32  
33  
34  
35  
36  
37  
38  
39  
40  
41  
42  
43  
45  
46  
47  
48  
49  
50  
51  
52  
53  
54  
55  
56  
57  
58  
59  
60  
61  
62  
63  
64  
65  
66