



Possible Grounding Schemes for 1394 Beta/Bilingual Connectors & Cables

Dave Brunker

Molex Inc

1999/April/28th

Ground Scheme Alternative #1



Minimum Isolation System:

- Shield tied to Frame Ground
- Signal returns commoned with power ground and isolated from shield

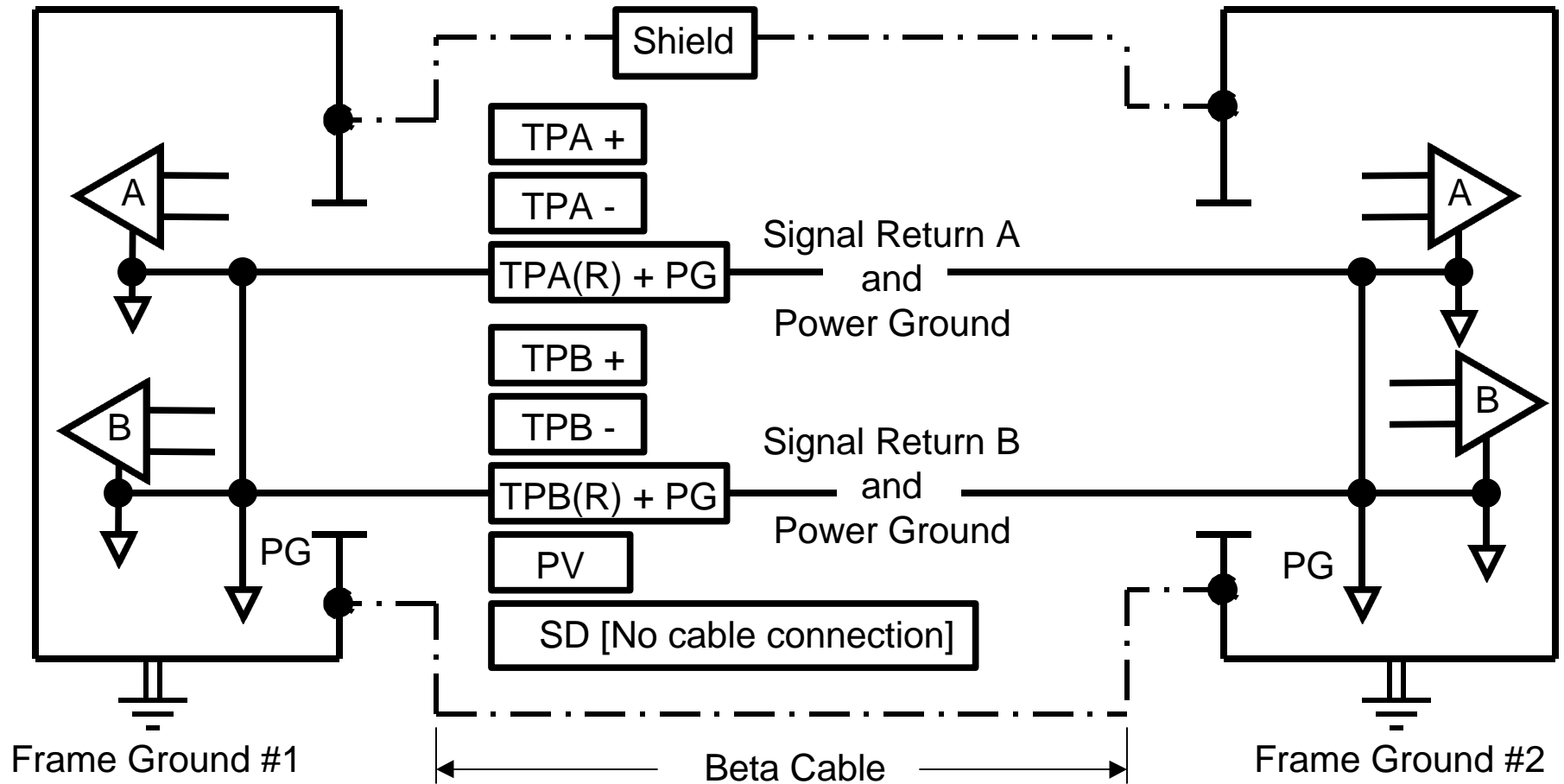

Ground Scheme Alternative #2



Frame to Frame Galvanic Contact:

- Shield tied to Frame Ground
- Signal returns isolated from power ground and fully dedicated to Rx input

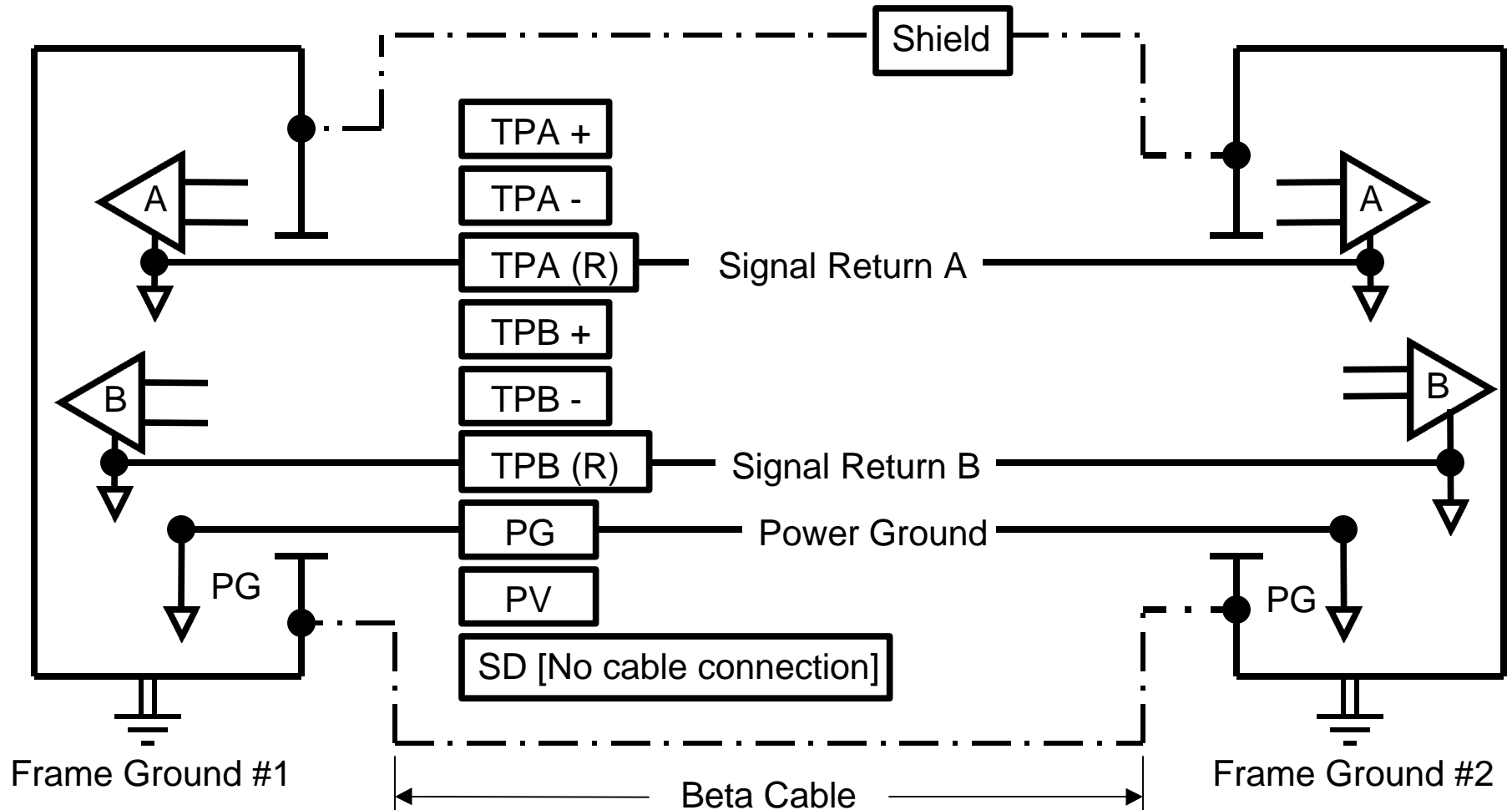

Ground Scheme Alternative #3



Full System Isolation:

- Shield isolated from Frame Ground
- Signal returns isolated from power ground and fully dedicated to Rx input

