



Fiber Jack Connector

IEEE 1394b

Don Wiencek
Panduit Corporation
September 23, 1997

Fiber Jack



TIA FOCIS-6 Connector for POF and GOF



Fiber Jack and IEEE 1394b

- Fiber Jack is the *only* TIA (FOCIS-6 and 'Detail' specification) and ISO/IEC (NWIP) connector compatible with POF *and* GOF
- Fiber Jack (POF) is an approved connector in the ATM RBB (Residential Broadband) draft standard
- Fiber Jack has been selling world-wide for the past nine months



*Successful standards employ
de facto standard products.*

Fiber Jack = SC/ST + RJ45



Fiber Jack Meets 1394b Criteria

Glass Optical Fiber

- Fiber Jack is currently being considered to replace the SC connector within TIA-568 (and TIA-570 by reference)
- Fiber Jack is being proposed by the US TAG to the IEC as a New Work Item Proposal (with the support of the ATM Forum)

**TIA Specification
DRAFT**

Detail Specification

Connector Set for Plastic Optical

Fibers and Cables

Type FOCIS-6 (Fiber Jack)

Environmental Category I

June 17, 1997



Fiber Jack Performance

<i>Test</i>	<i>Required Performance</i>	<i>Fiber Jack Typical Results</i>
FOTP-34 Insertion Loss	< 0.75dB max	< 0.15 dB typical
FOTP-185 Coupling Strength	> 25 lbs.; < 0.75dB max	No increase
FOTP-2 Impact	< 0.3dB increase	No increase
FOTP-1 Flex	< 0.3dB increase	No increase
FOTP-4 High Temperature	< 0.3dB increase	< 0.14dB increase
FOTP-21 Mating Durability	500 cycles; < 0.3dB increase	No increase
FOTP-5 Humidity	< 0.3dB increase	No increase
FOTP-6 Cable Retention	>15 lbs.; < 0.3dB increase	No increase
FOTP-36 Twist	3.3 lbs.; < 0.3dB increase	No increase
FOTP-71 Temperature Shock	< 0.3dB increase	< 0.15dB increase
FOTP-188 Low Temperature	< 0.3dB increase	No increase
FOTP-11 Vibration	< 0.3dB increase	< 0.11dB increase



Fiber Jack Insertion Loss

Multimode (FOTP-34)

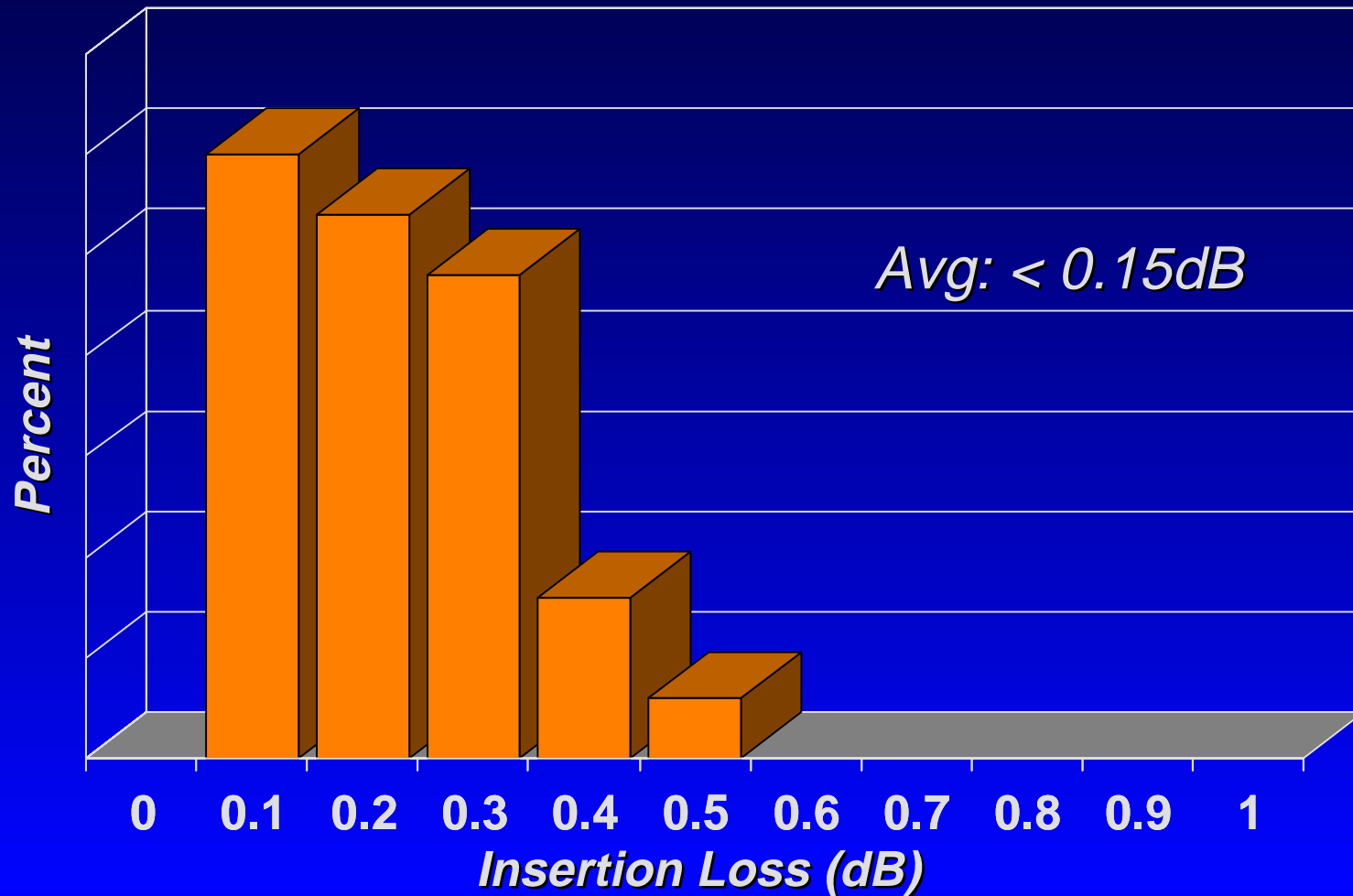



Fiber Jack Insertion Loss

Single-mode (FOTP-34)

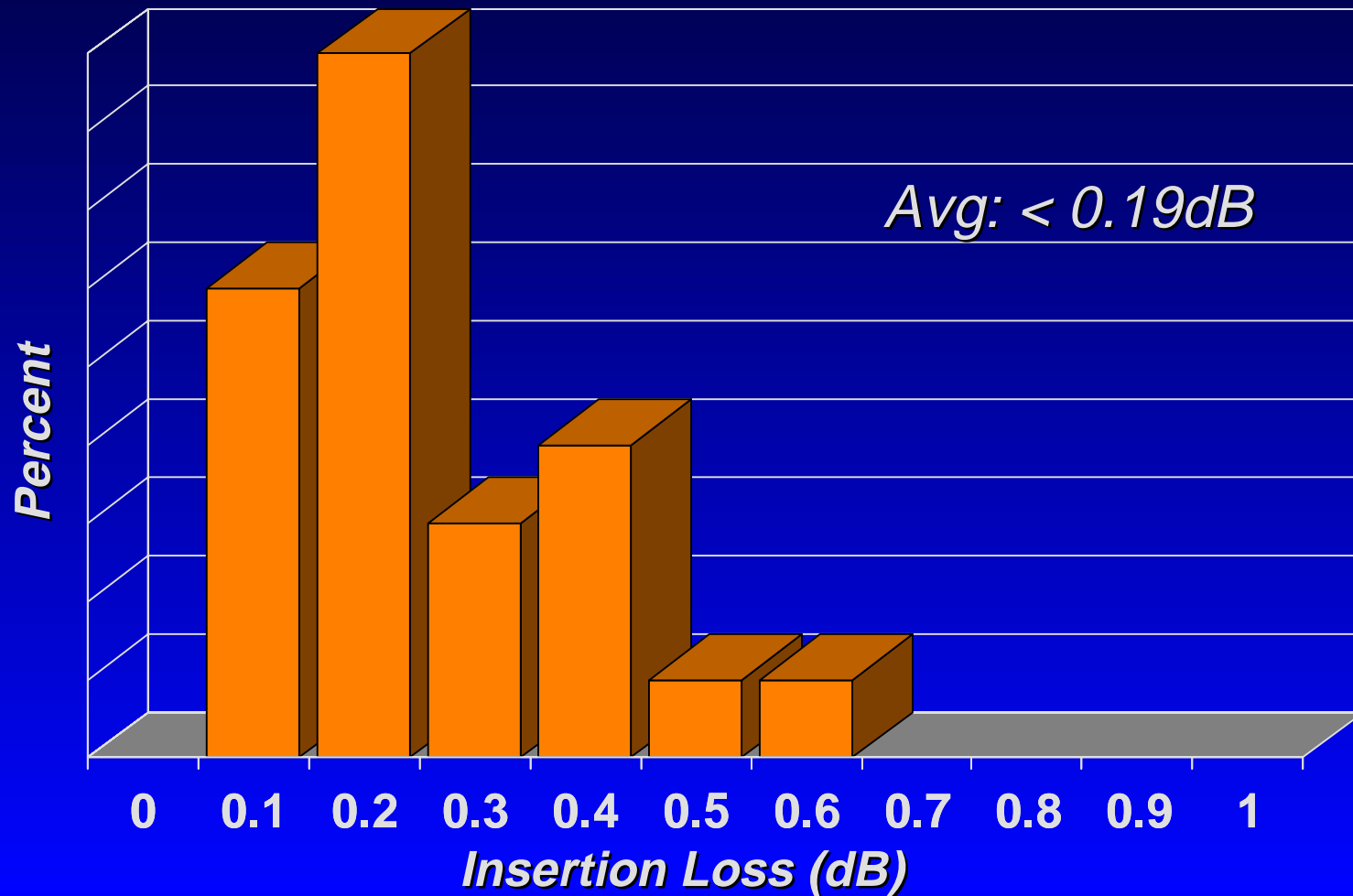



Highlights of GOF Fiber Jack

- *Safe* (fragile fibers are protected by using *proven* ferrule technologies)
- Mechanically robust for 20 year lifespan in the home
- Small size, superior ergonomics, adapterless, flush mounted jacks (*same as RJ-45*)
- Field and factory terminable for both jacks and plugs with standard tools and cable
- Fits within all existing outlets, panels, enclosures, etc.
- Ferrule protected fibers can be properly cleaned



Fiber Jack Meets 1394b Criteria

Plastic Optical Fiber

- Cost is equal to or lower than RJ-45
- Termination time can be faster than RJ-45
- Already accepted by the ATM Forum
- 100 meter transmissions at > 100 Mbps



**The ATM Forum
Technical Committee**

**155 Mbps Plastic Optical
Fiber and Hard Polymer
Clad Fiber PMD
Specification**

AF-PHY-POF155-0079.000

May, 1997

NOTE 2: The improved minimum receiver input power for the HPCF receiver interface is due to the more efficient optical coupling from the smaller diameter HPCF into the same optical detector to achieve a minimum detected current which yields a BER of $10E-10$. The interface point for the minimum receiver input power specification is located between the plug of the connector and the receptacle.

NOTE 3: The receiver eye opening represents the time interval allocated for the clock recovery function after the optical to electrical conversion at the receiver.

2.1.4.4 Jitter

The following jitter specifications apply for the POF and HPCF interface.

(R) The transmit interface jitter shall be as specified in section 2.1.4.2.

(R) The receiver interface jitter shall be as specified in section 2.1.4.3.

The receiver jitter tolerance and the jitter transfer through the interface are for further study. Note that the jitter transfer specification is only applicable when the interface is synchronized to the recovered clock.

2.1.5 Physical media interface

(R) The optical fiber interface should be the PN receptacle and the duplex F07 plug or PN plug and should meet the interface standard, IEC 1754-AA (NWIP) and the performance standard, IEC 1753-BB(FFS). It is presumed that the PN receptacle accepts the PN plug and the duplex F07 plug. An example is shown in figure 1. The performance of the connector shall be tested by a standard test method (FFS)³. It is recommended that the network polarity (transmit and receive) be managed in accordance with ANSI/TIA/EIA-568-A. Alternative connector styles are for future study to be defined by the IEC.

(R) The worst case connector insertion loss, including the effect of environmental conditions, shall be less than 1.3 dB for POF and 2.0 dB for HPCF.

³ The standard test method for the connector is proposed for development in the IEC.

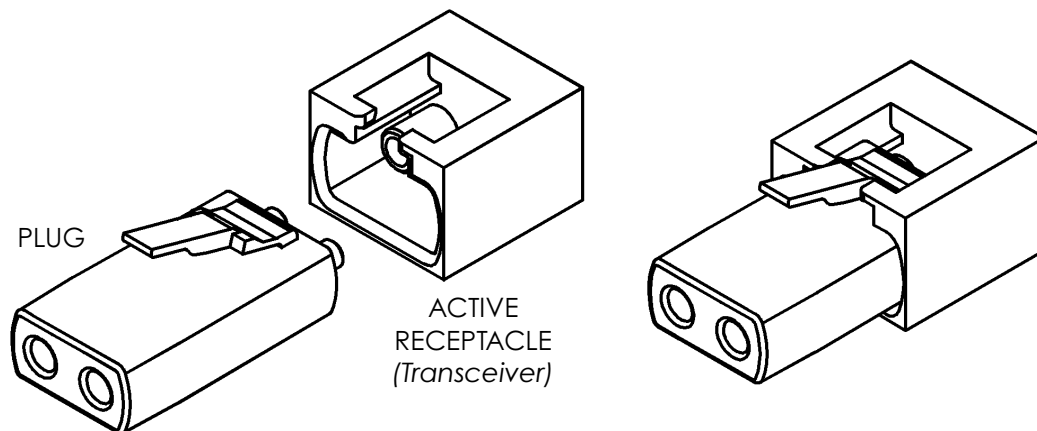

Figure 1b Physical Media Plug and Receptacle
Example (Fiber Jack, TIA PN3871)

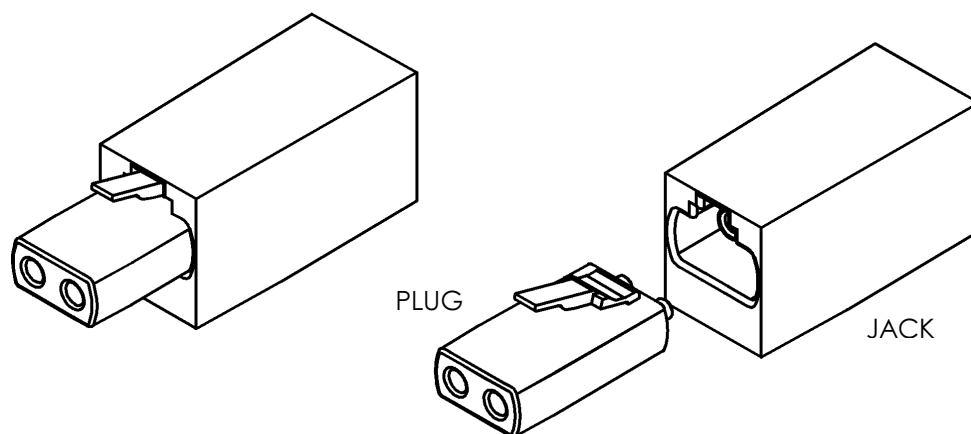
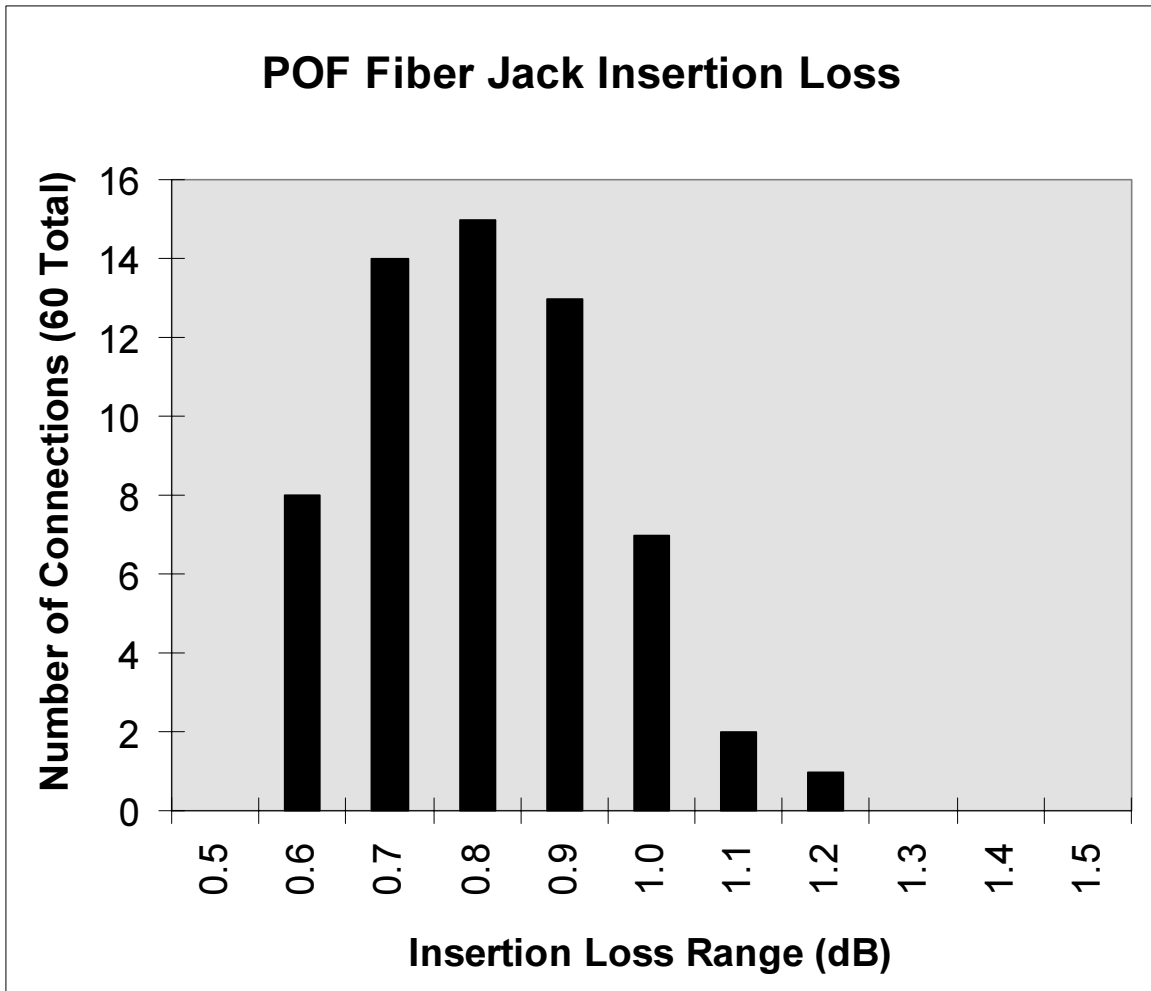

Figure 1c Physical Media Plug and Jack
Example (Fiber Jack, TIA PN3871)

III. Fiber Jack Optical and Mechanical Performance:

The POF FIBER JACK was tested in compliance with the industry standard test methods which have been proven reliable for glass optical fiber connectors. The test sequence followed Environmental Category II specifications. The following test results reflect the performance of 60 POF connections.

Insertion Loss FOTP-34:



Maximum specified insertion loss: 1.3 dB

Average insertion loss: 0.87 dB

Standard deviation: 0.13 dB

Maximum tested insertion loss: 1.23 dB



Connector Requirements P1394b

- **Single Interface for All Media**
 - **Fiber Jack specified for both POF and GOF**
- **Low Cost**
 - **POF Yes**
 - **GOF Not yet**
- **20 Year Life**
 - **POF - FOTP Test**
 - **GOF - 20 plus years of history**



Connector Requirements P1394b

- Suitable for Equipment, Wall Plates, etc.
 - e.g Pan-Net
- Suitable for Multi-mode Fiber
 - *OPTI-JACK™* Fiber Optic Connector
- Low Loss < 1.5 db
 - GOF less than .75 db
 - POF less than 1.5 db
(less than 2.0 db (PJ-2))



Connector Requirements P1394b

- Pre-Assembled Patch Cords
 - Currently Available
 - Both Plug and Jack are Field Terminable
- Assist Physical Safety
 - POF inherently safe
 - GOF safe due to standard SC/ST Ferrules



Connector Specification P1394b

- Easy Termination
 - POF Yes
 - GOF In development
- Standards in Progress
 - TIA, IEC, ATM, IEEE, VESA HN
- Small Size, Duplex, Asymmetric
 - RJ-45 Design

Proposal

The following proposed text is intended to be added to section 1.13 of the draft baseline IEEE p1394b text. Since the TIA/EIA and ISO/IEC are completing the Intermateability standards regarding the Fiber Jack connector, the dimensional details are not included here.

Fiber Jack Connector

The Fiber Jack (FJ) receptacle, jack and plug shall meet the interface standard TIA FOCIS-6 (ANSI PN#3871) and Plastic Optical Fiber FJ Detail performance standard (ANSI PN#3872). Network polarity (transmit and receive) are to be managed in accordance with ANSI/TIA/EIA-568-A.

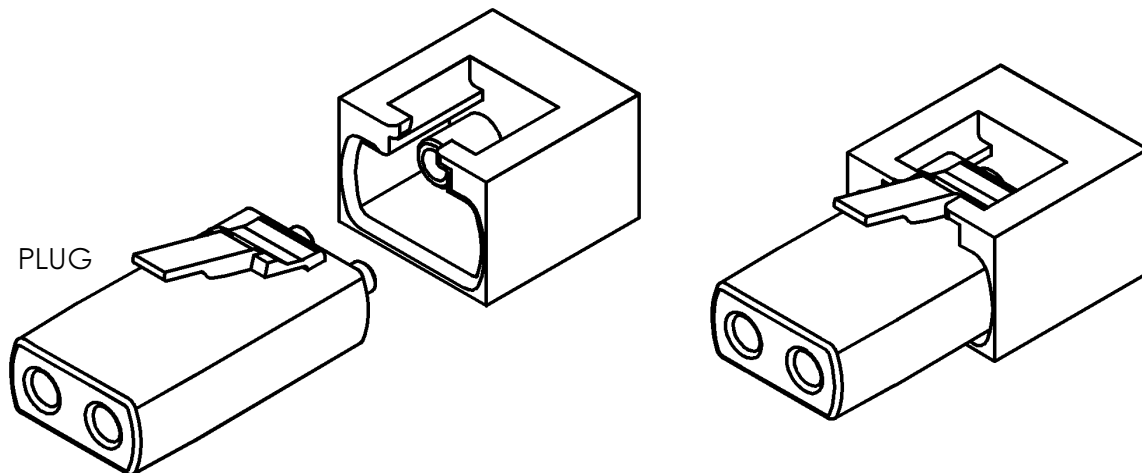

Figure 4 Physical Media Plug and Receptacle/Jack

The parent connector for type FJ connector family is a duplex plug and jack which is characterized by a modular plug and jack latching style and 2.5 mm nominal ferrules set on a 6.25 mm pitch. There are two plugs, the PJ-1 and PJ-2. The PJ-1 independently spring loads the ferrules into which the two fibers are mounted. The PJ-2 is a low-cost type comprised of a one piece body and fiber retaining clip. The two plugs have mechanical compatibility with the Fiber Jack style jack. The FJ interface is described by TIA/EIA FOCIS-6 and ISO/IEC XXXX (NWIP).