

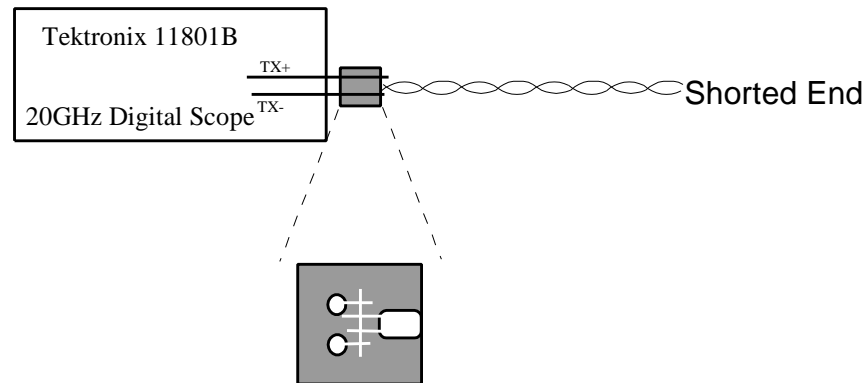

1394 Connector and Cable Studies

Experimental Setup

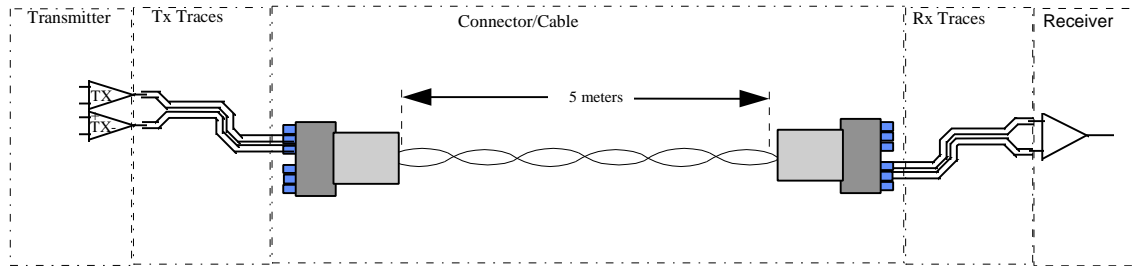



Connector TDR Data

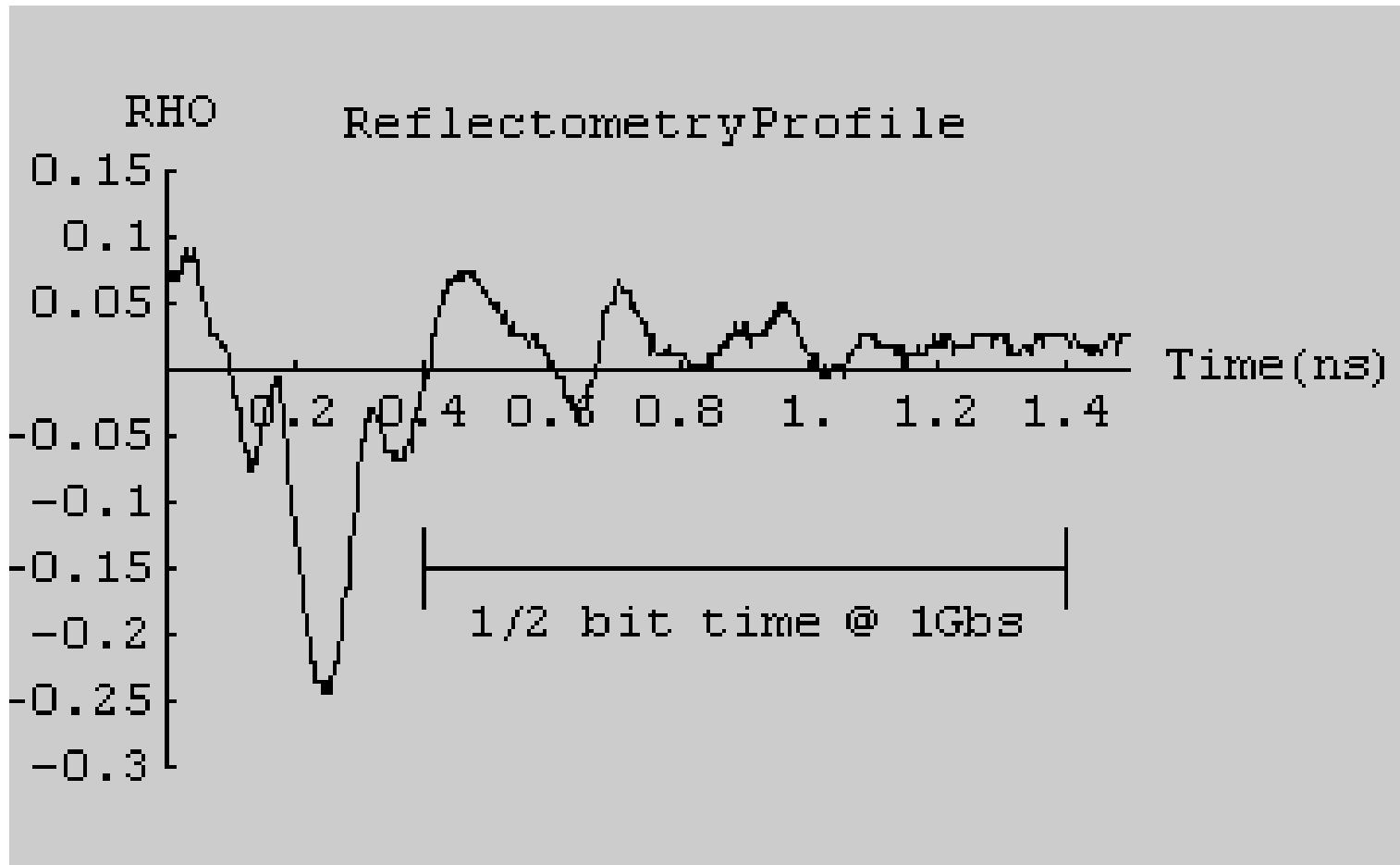

Opened Pins

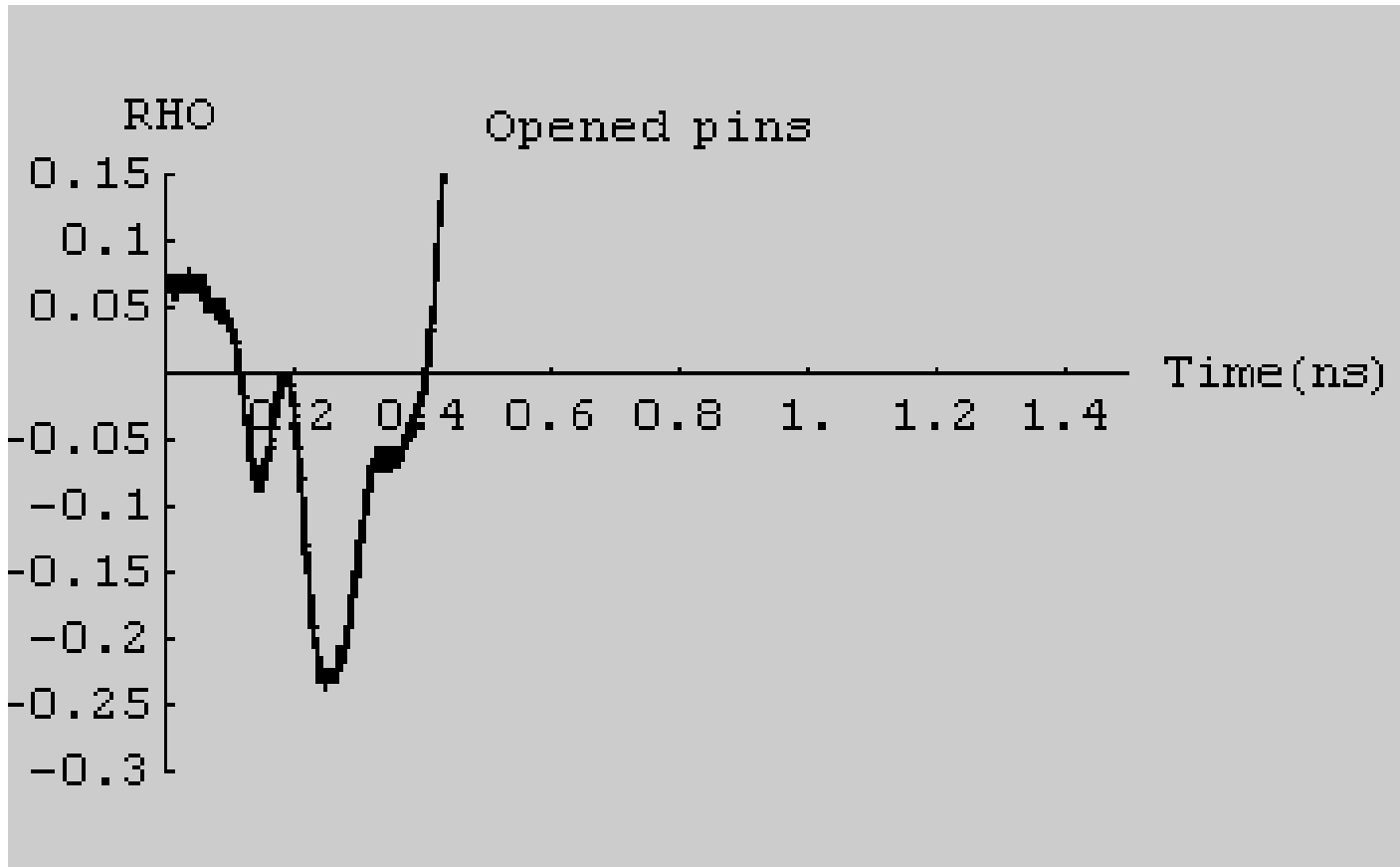



100 ps Smoothing

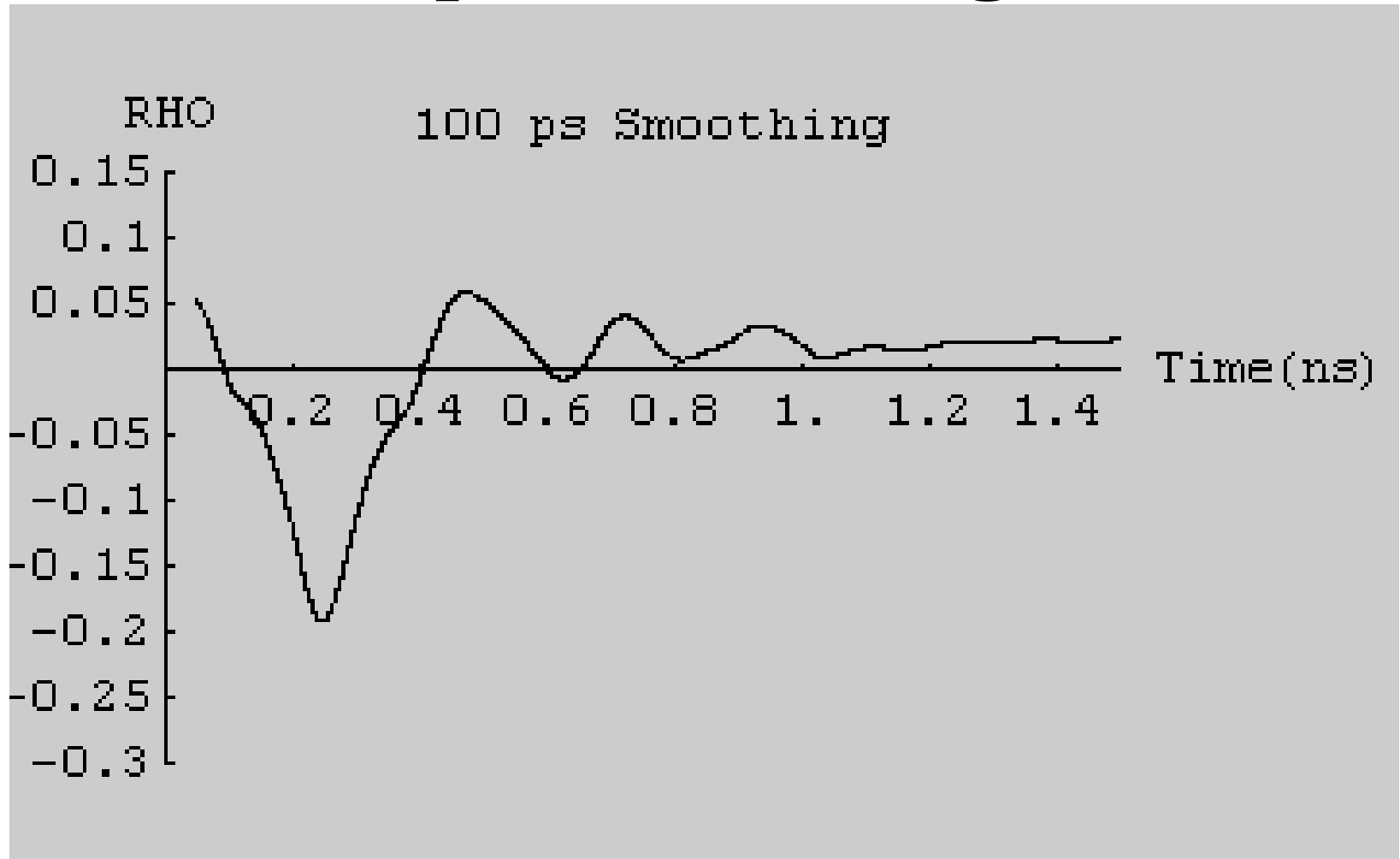



Impedance Profile

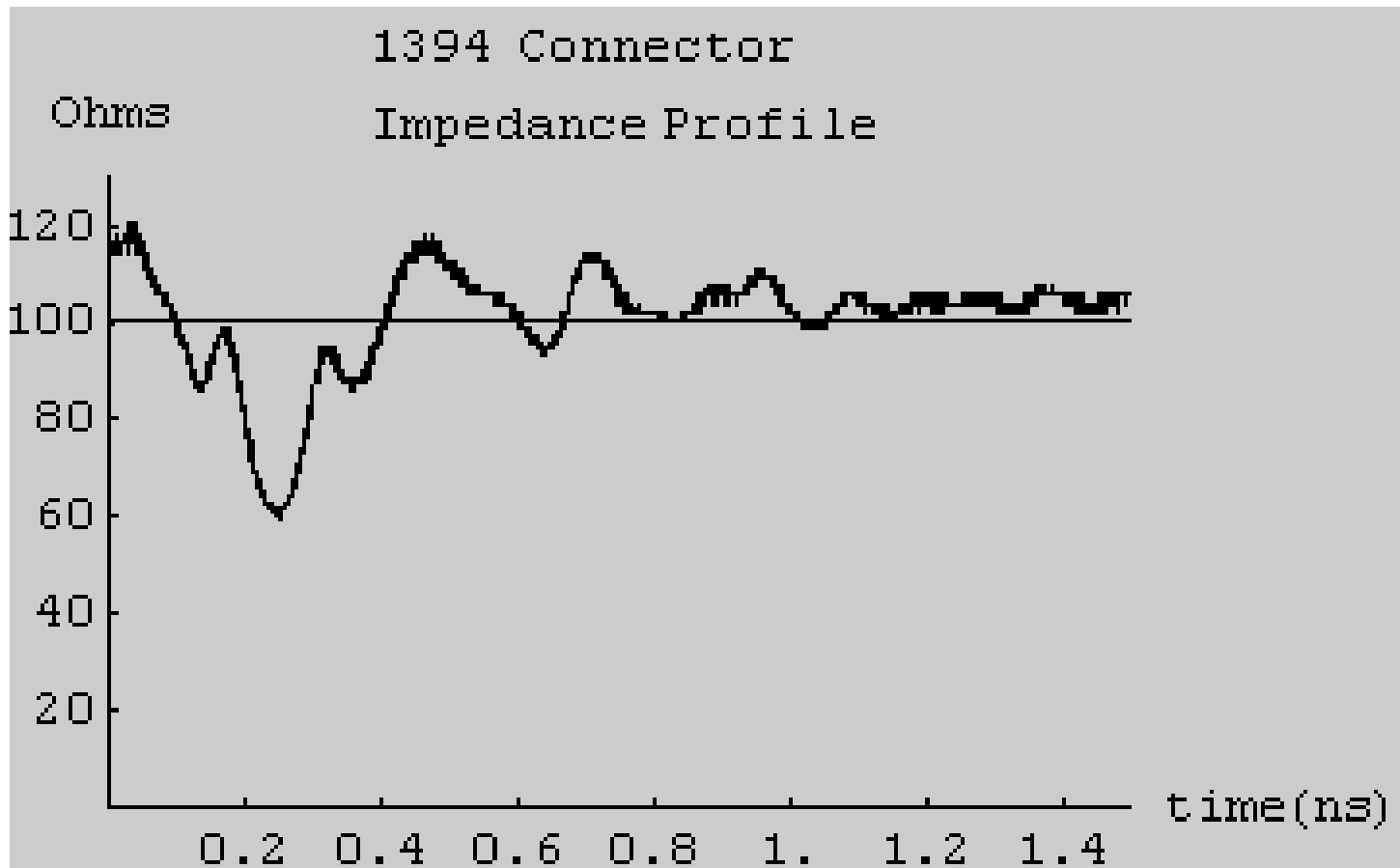

Complex Impedance Profile

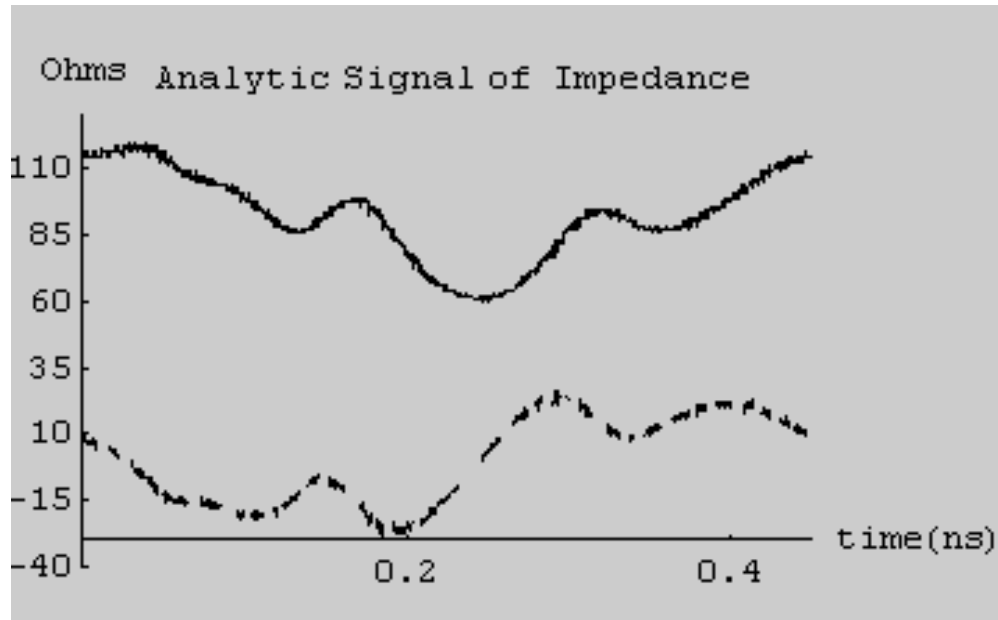

The definition of the transmission coefficient (S_{12}) is :

$$S_{12}(\omega) = T(\omega) = \frac{2Z_{\text{load}}(\omega)}{Z_{\text{load}}(\omega) + Z_0(\omega)}$$

Similarly the definition of the reflection coefficient (S_{11}) is :

$$S_{11}(\omega) = R(\omega) = \frac{Z_{\text{load}}(\omega) - Z_0(\omega)}{Z_{\text{load}}(\omega) + Z_0(\omega)}$$

S Parameters Calculation

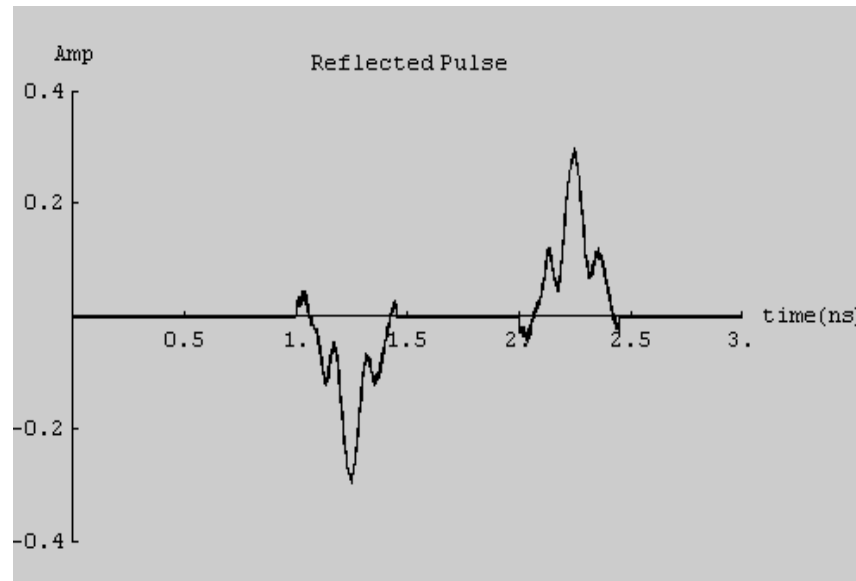
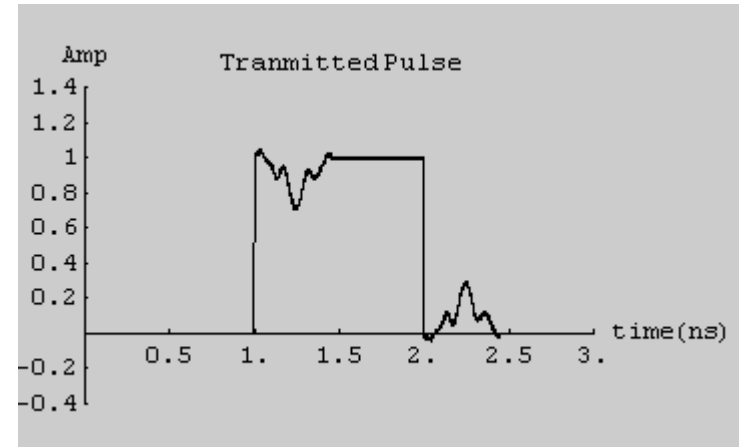
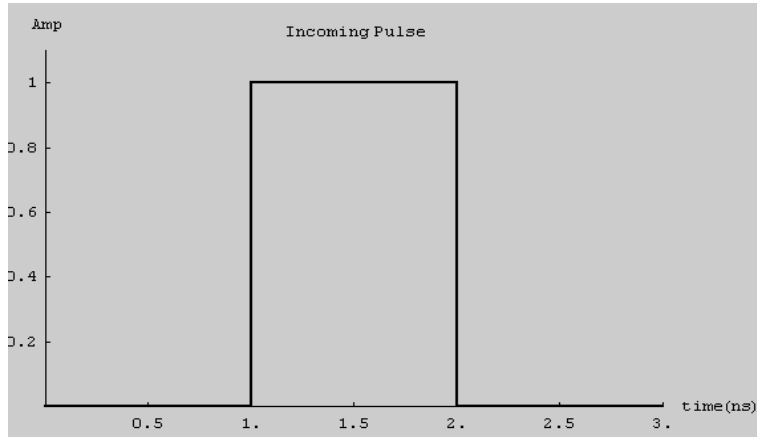



S Parameters

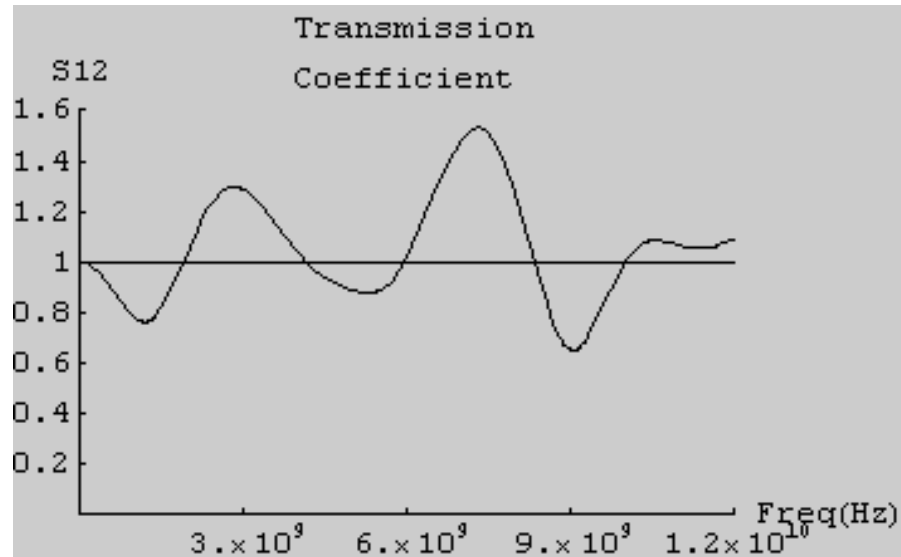
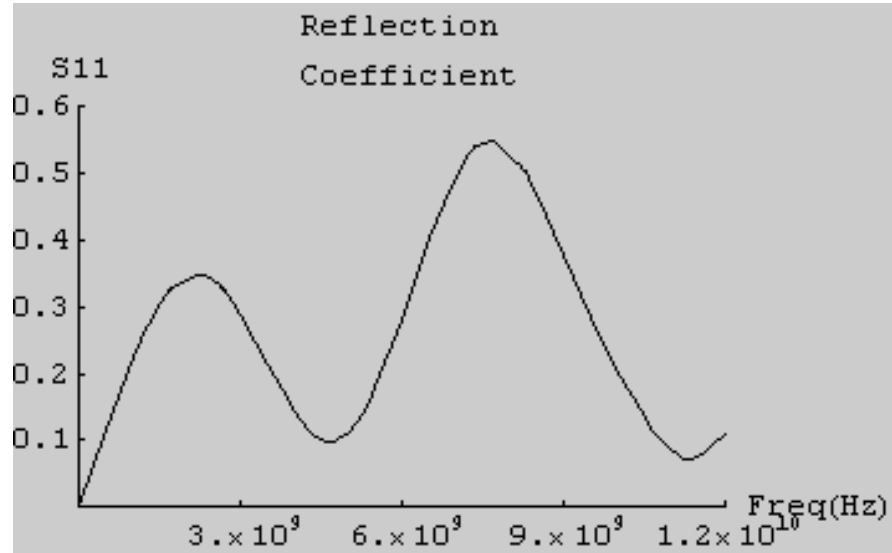

Back Calculation of TDR

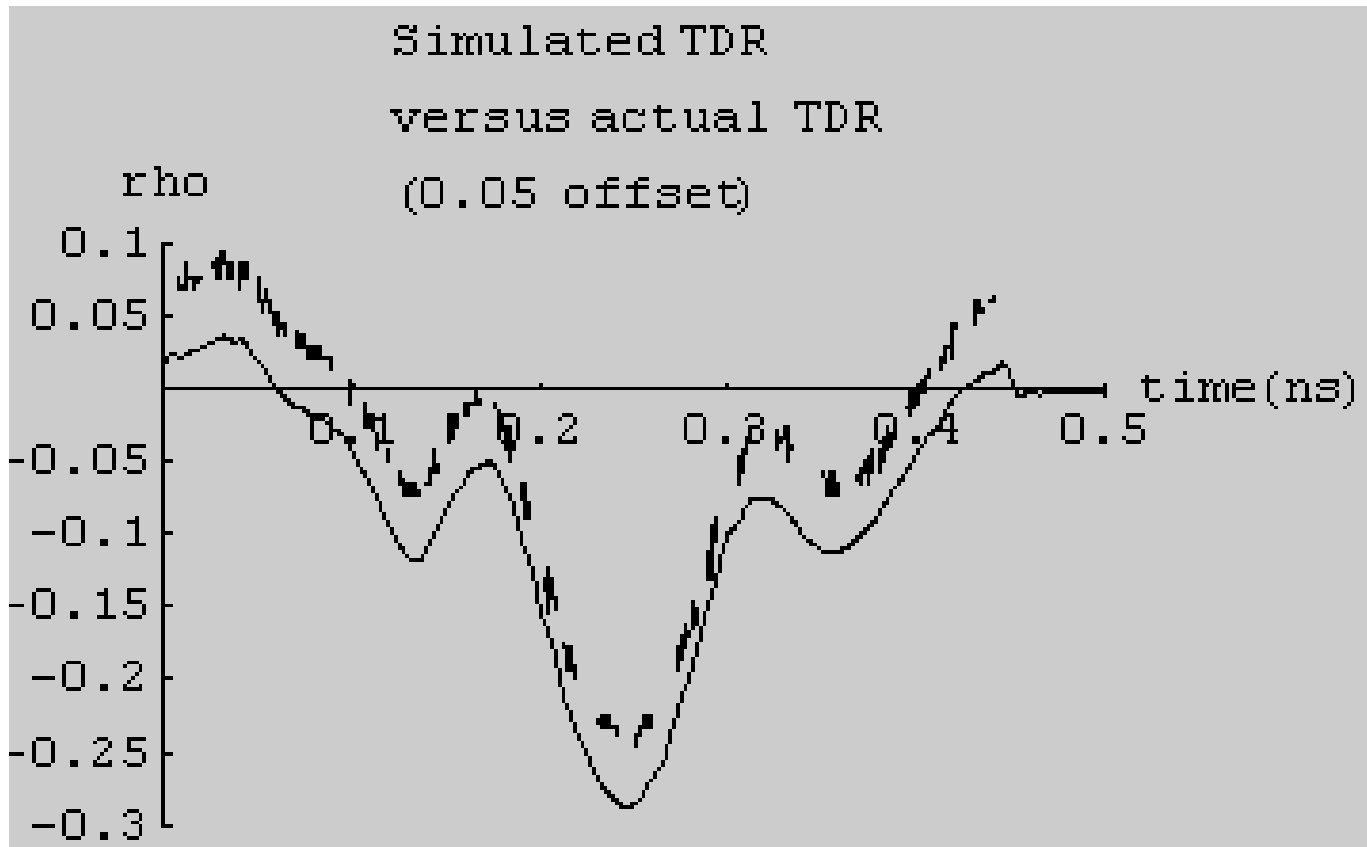



Cable Model

$$\partial_z v[z, t] == -r i[z, t] - l \partial_t i[z, t]$$

$$\partial_z i[z, t] == -g v[z, t] - c \partial_t v[z, t]$$

$$r_{\text{internal}} = \begin{cases} r_{dc} \left(1 - i \frac{f}{f_0} \right), & f \leq f_0 \\ r_{dc} \sqrt{\frac{f}{f_0}} (1 - i), & f > f_0 \end{cases}$$

Ideal Skin Depth Effect



Experimental Cable Analysis

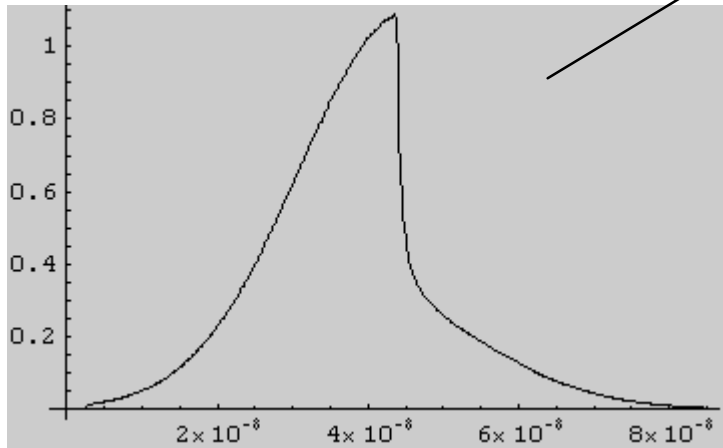
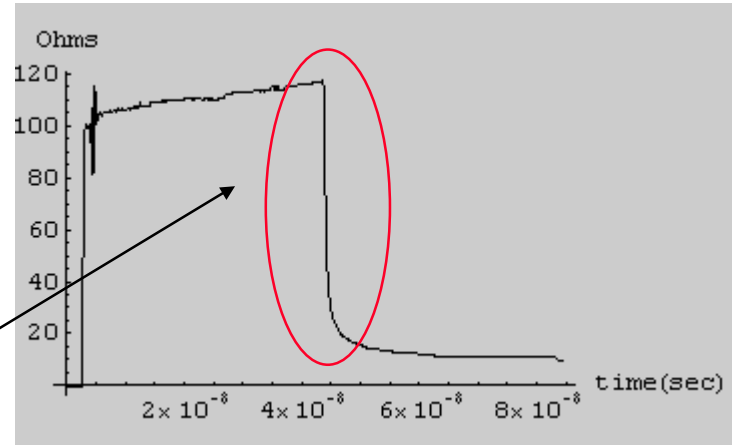
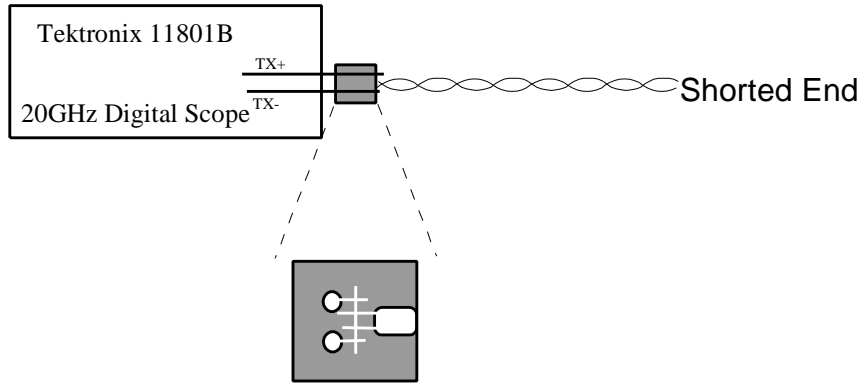

Return Pulse multiplied by a Gaussian windowing function

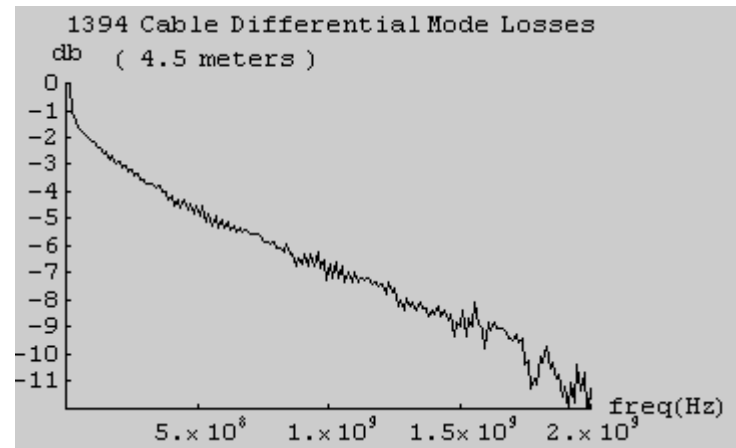



Back Simulation of Cable Data

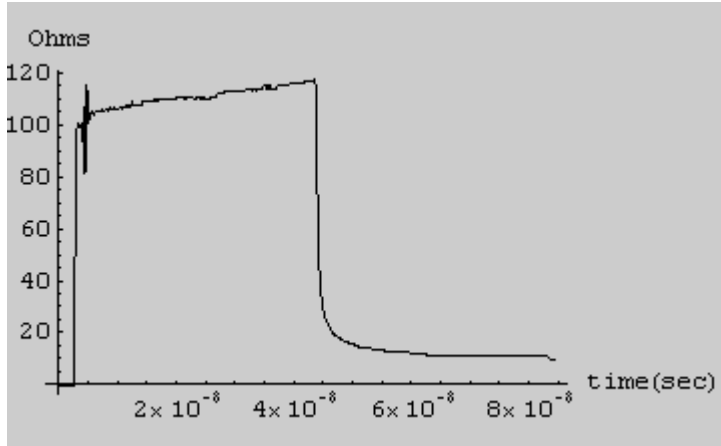

Experiment

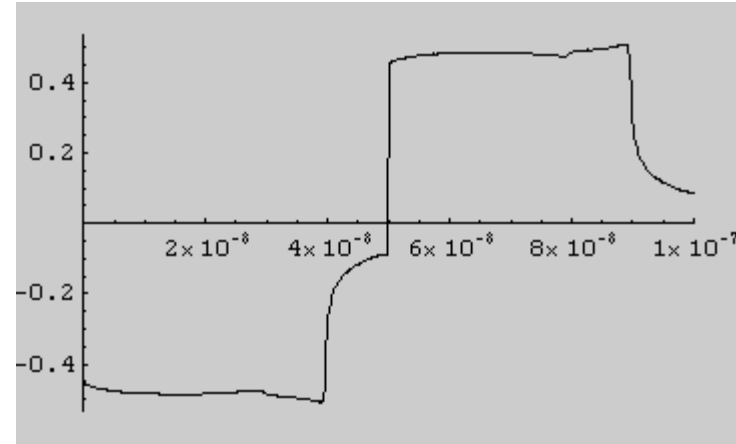

Model

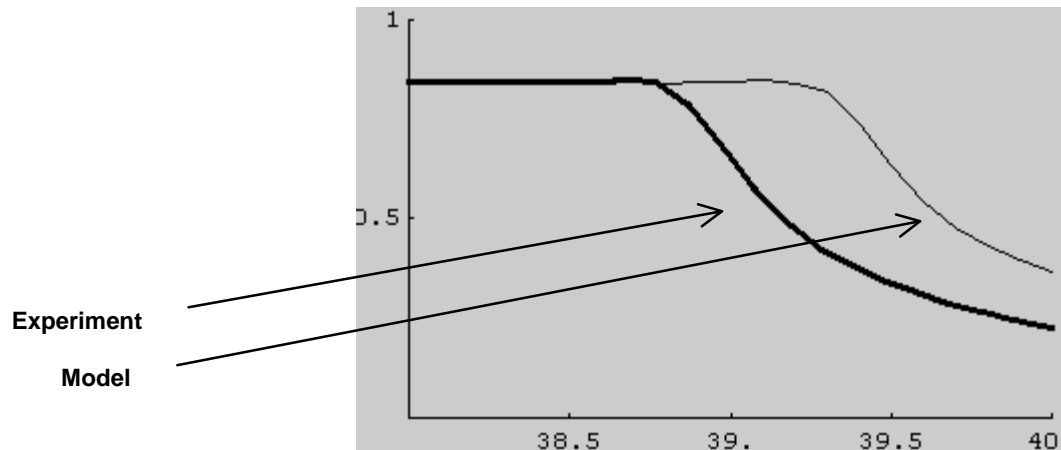

Return Pulse Corner Detail



Simulated Cable/Connector Transfer Amplitudes

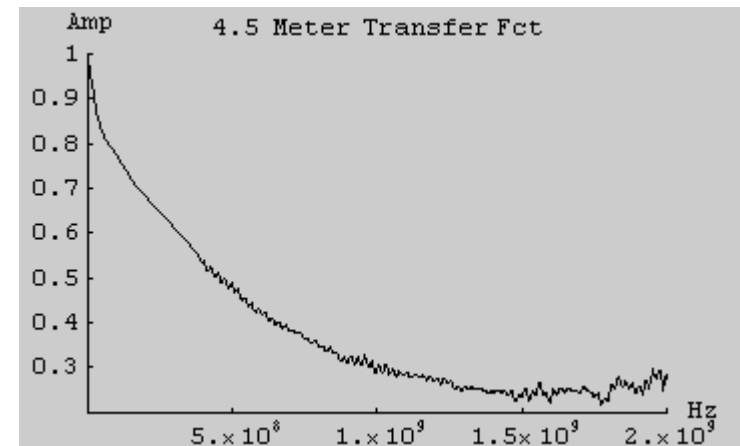
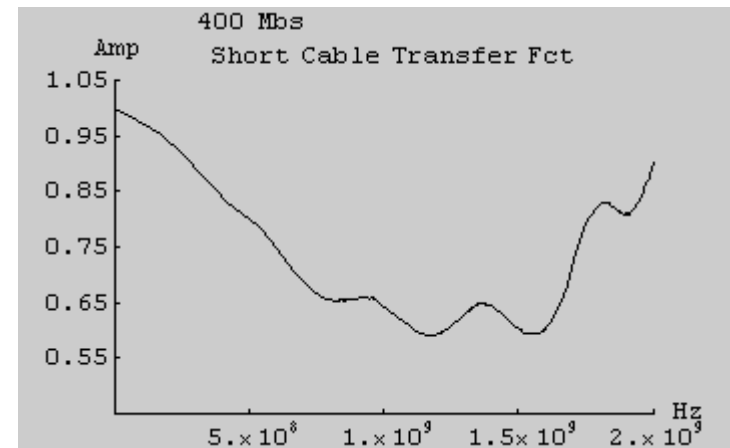
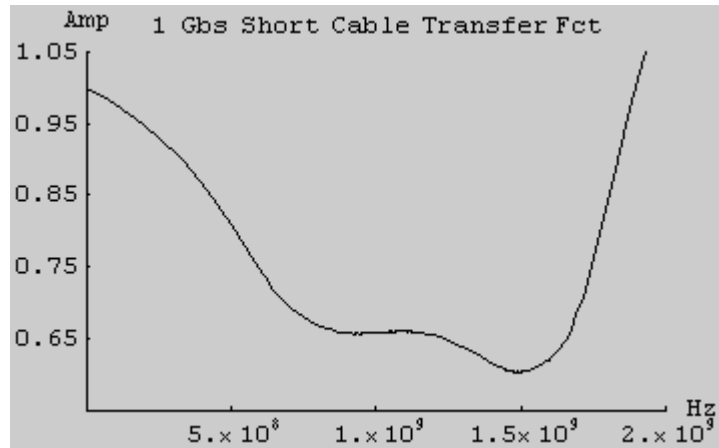

$$S_{\infty} = \frac{H(\omega) T^2(\omega)}{1 - R^2(\omega) H^2(\omega)}$$



Bit Test Pattern

11000001010011111010100000000000000000000000

00000101111111111111111111111111111110 ... repeating



Simulated Eye Diagrams

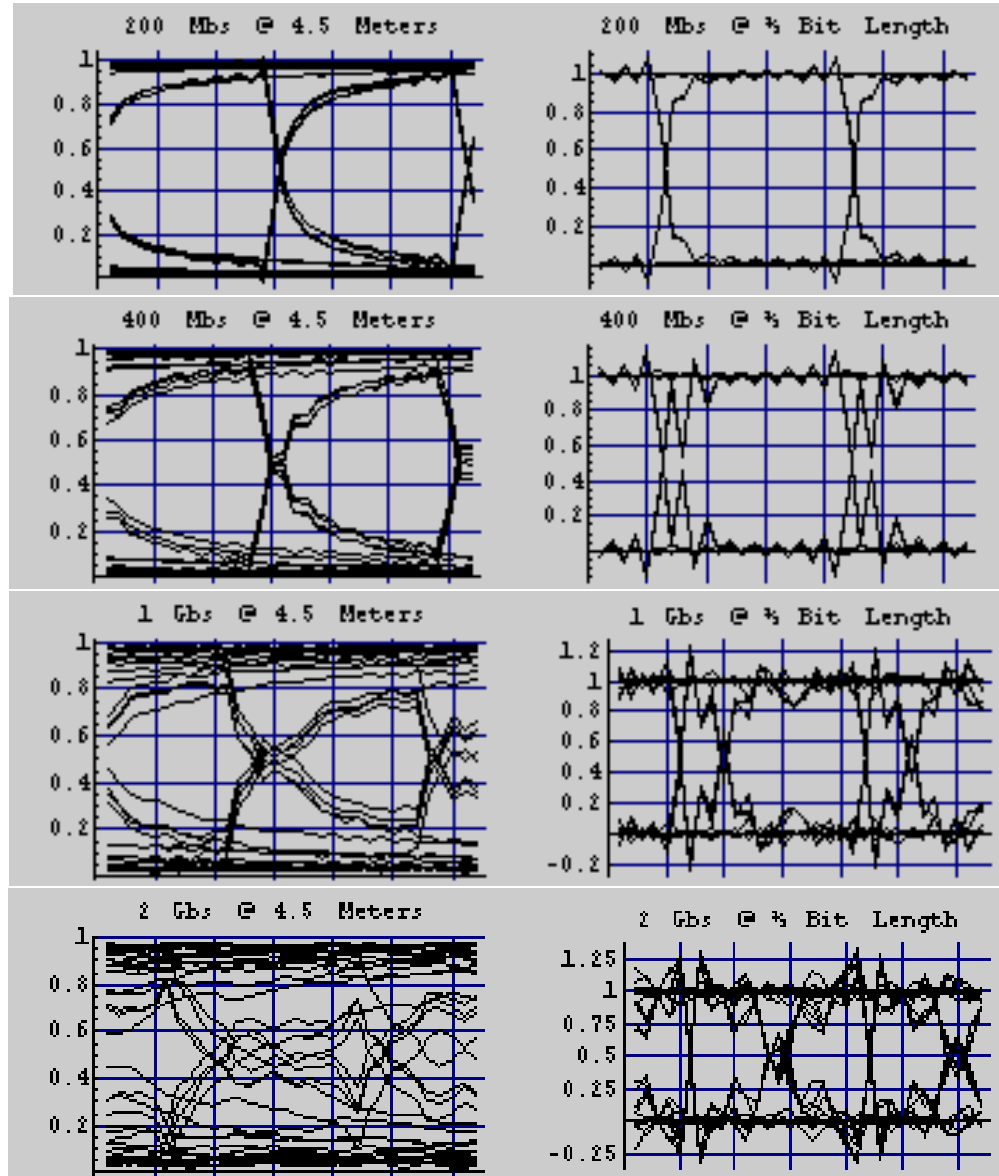



400 Mbs Short Cable Simulation

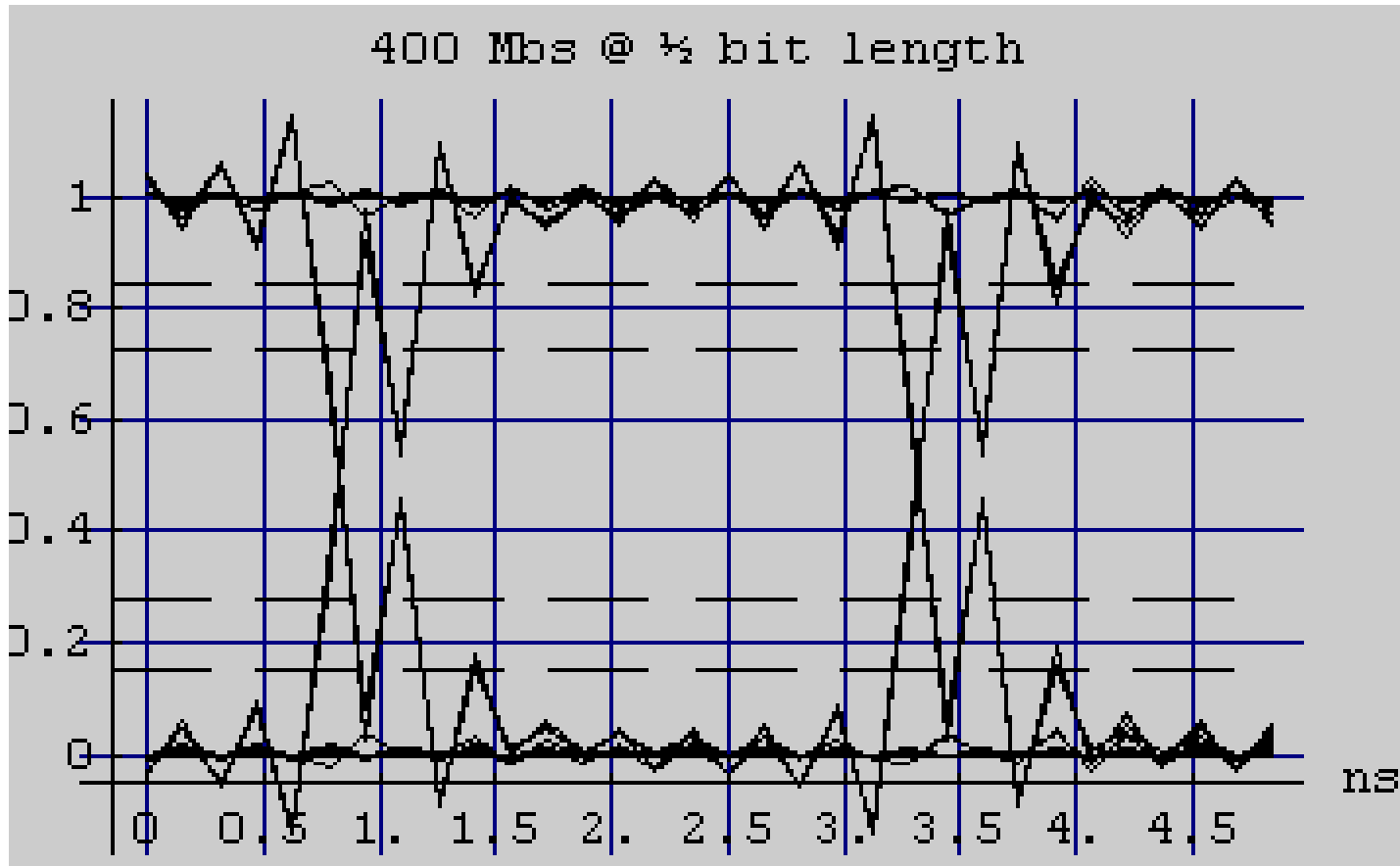



400 Mbs 4.5 Meter Simulation

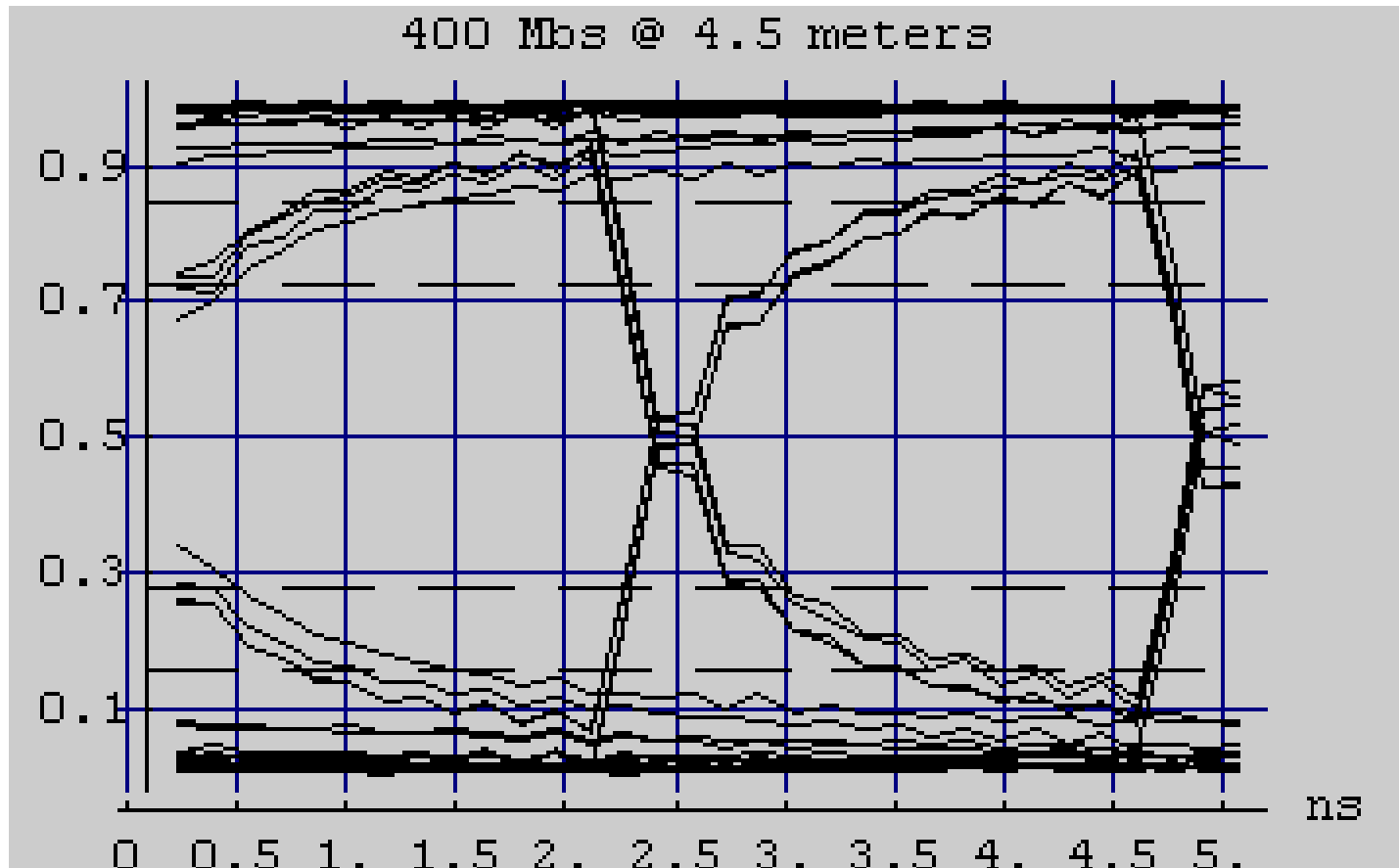



Experimental Results

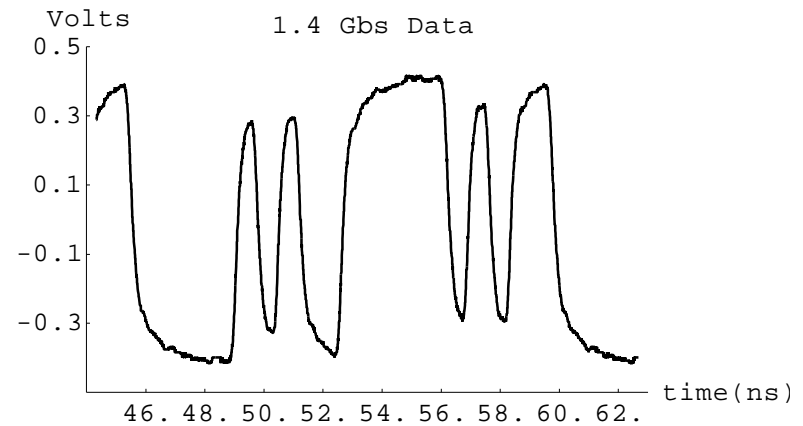
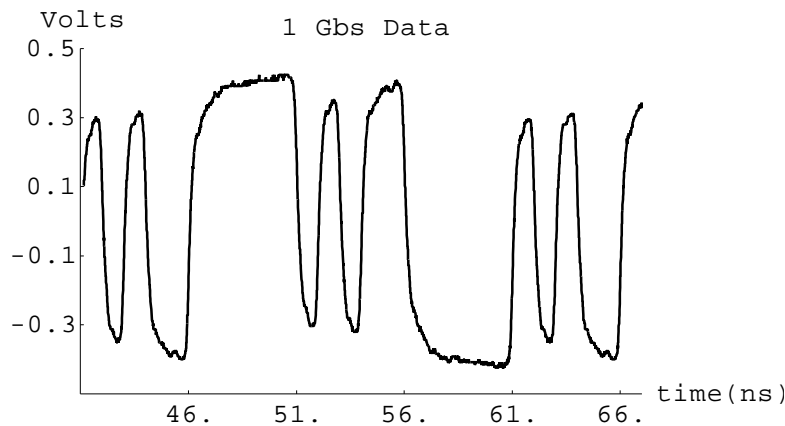
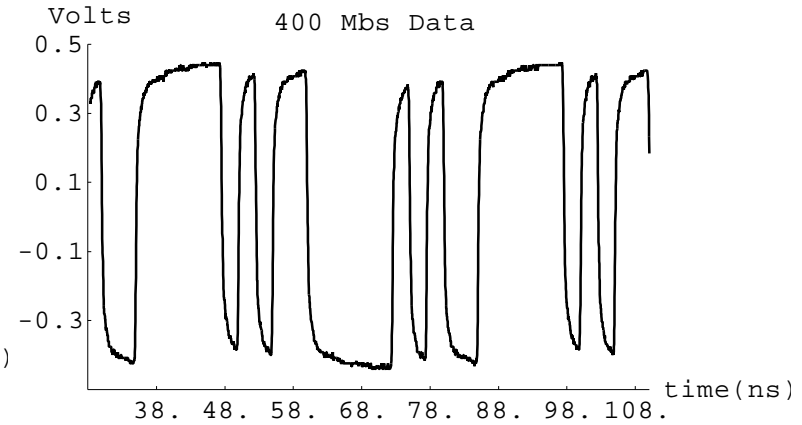
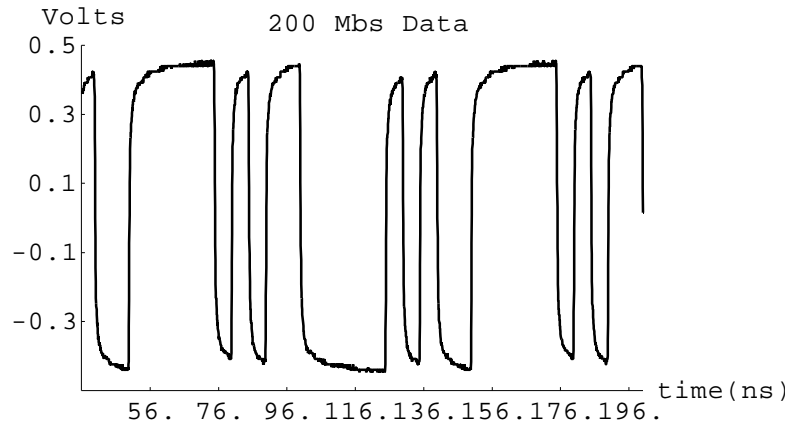



Experimental Eyes

