

VF-45 Duplex Fiber Optic Interconnect

PROPOSAL

IEEE P1394b Meeting

Natick, MA

September 23, 24 1997

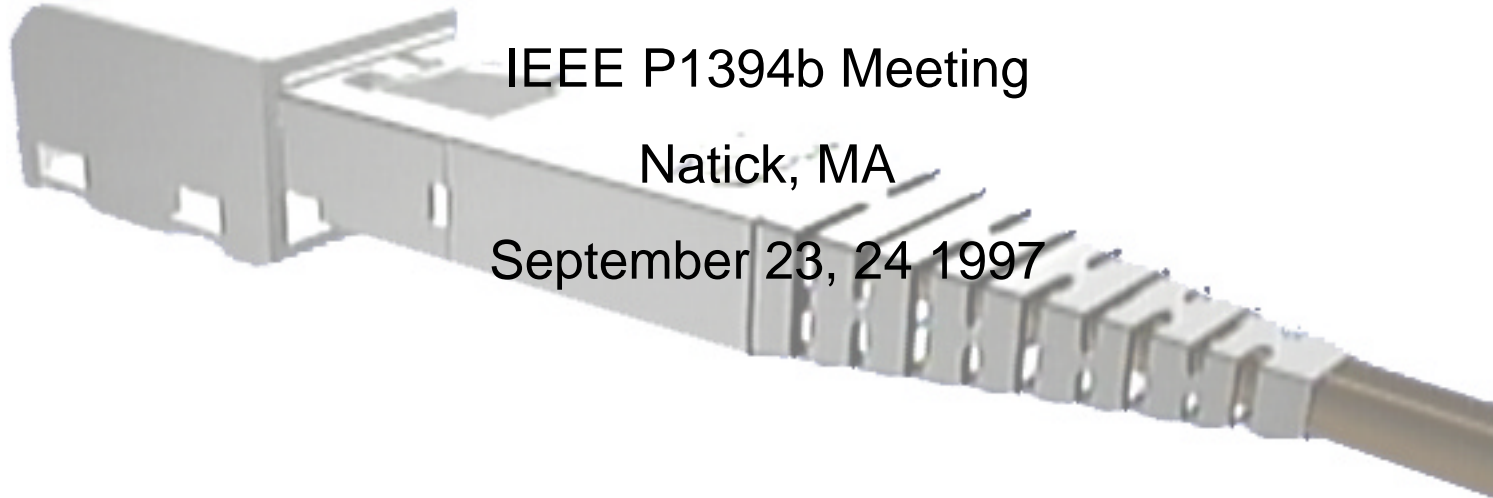

Juan Pulido
3M Company
6801 River Place Blvd.
MS A130-2N-13
Austin, TX 78726
Tel: 512.984.5188
E-mail: JMPULIDO@mmm.com

3M Volition™ Cabling System



Fiber-To-The-Desk System



3M Volition™ Cabling System

Applications Driving Fiber Demand

- Growth of powerful computer applications
- Continued increase in computer processing power
- Bandwidth for future applications
- EMI, RFI and Cross talk on copper
- Minimize cabling changes every 3-4 years
- Telecommuting/Internet/ “SMART HOMES”
- Increasing need to network these applications at high speed



Benefits of Fiber Cabling Systems

- Proven technology in backbones
- Greater flexibility
- Future-proofed for any bandwidth
- Marketable real estate (FTTD)
- Home wiring for life thus reducing cost and need to re-cable often



IT Trends

- Computing power doubles approximately every 2 years
- Projected data rates of 10 Mbps - ??Gbd
- New software utilizes all available computing power
- End users demand the ability to network applications at high speeds (Client-Server-Networks-Internet)

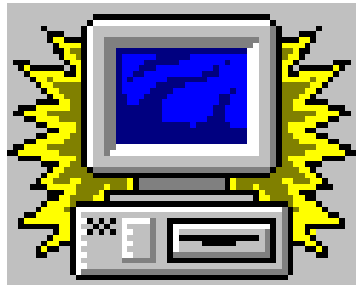

What Path for the Future?

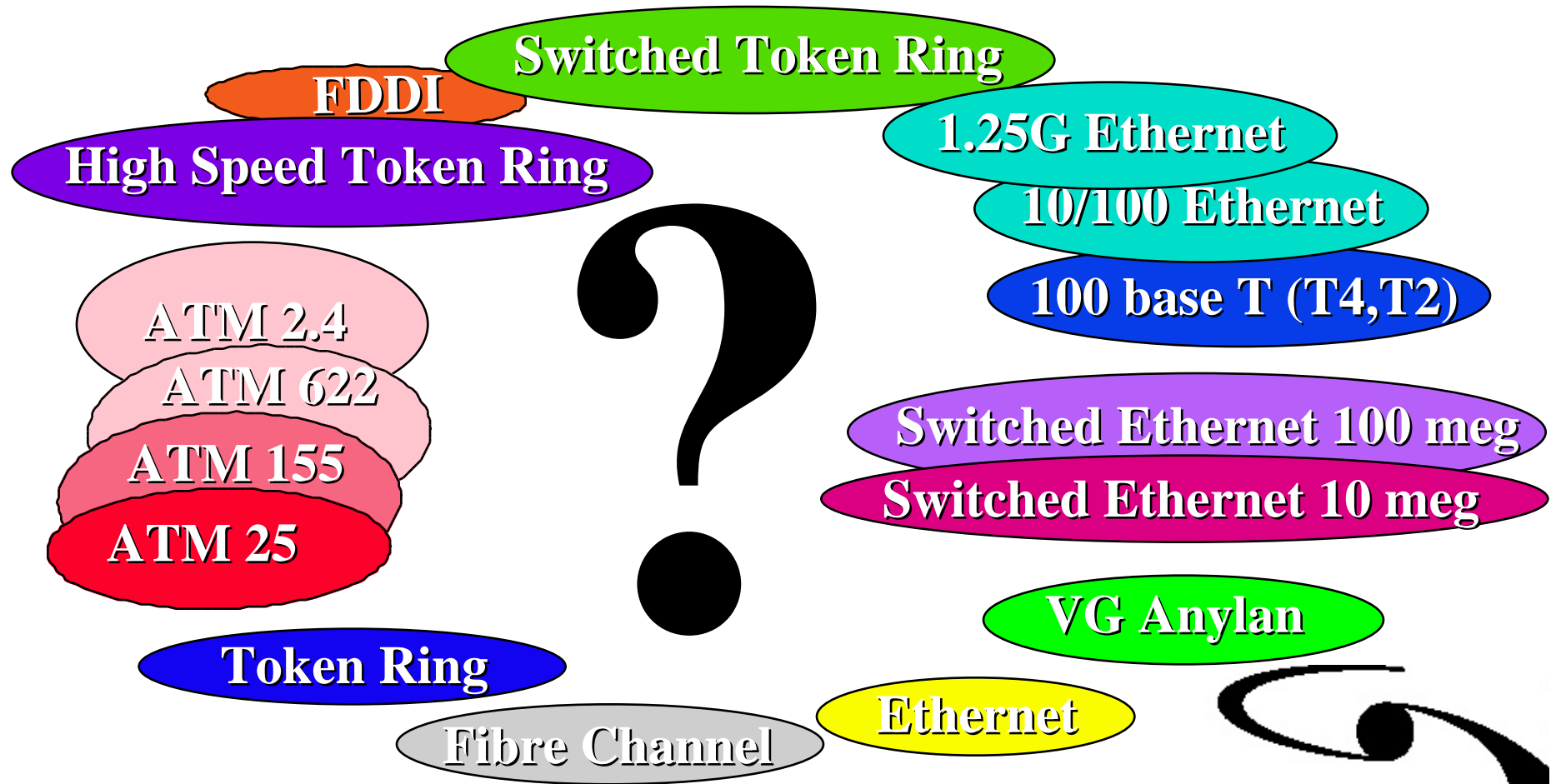

ONE CABLING SOLUTION!!

Bandwidth

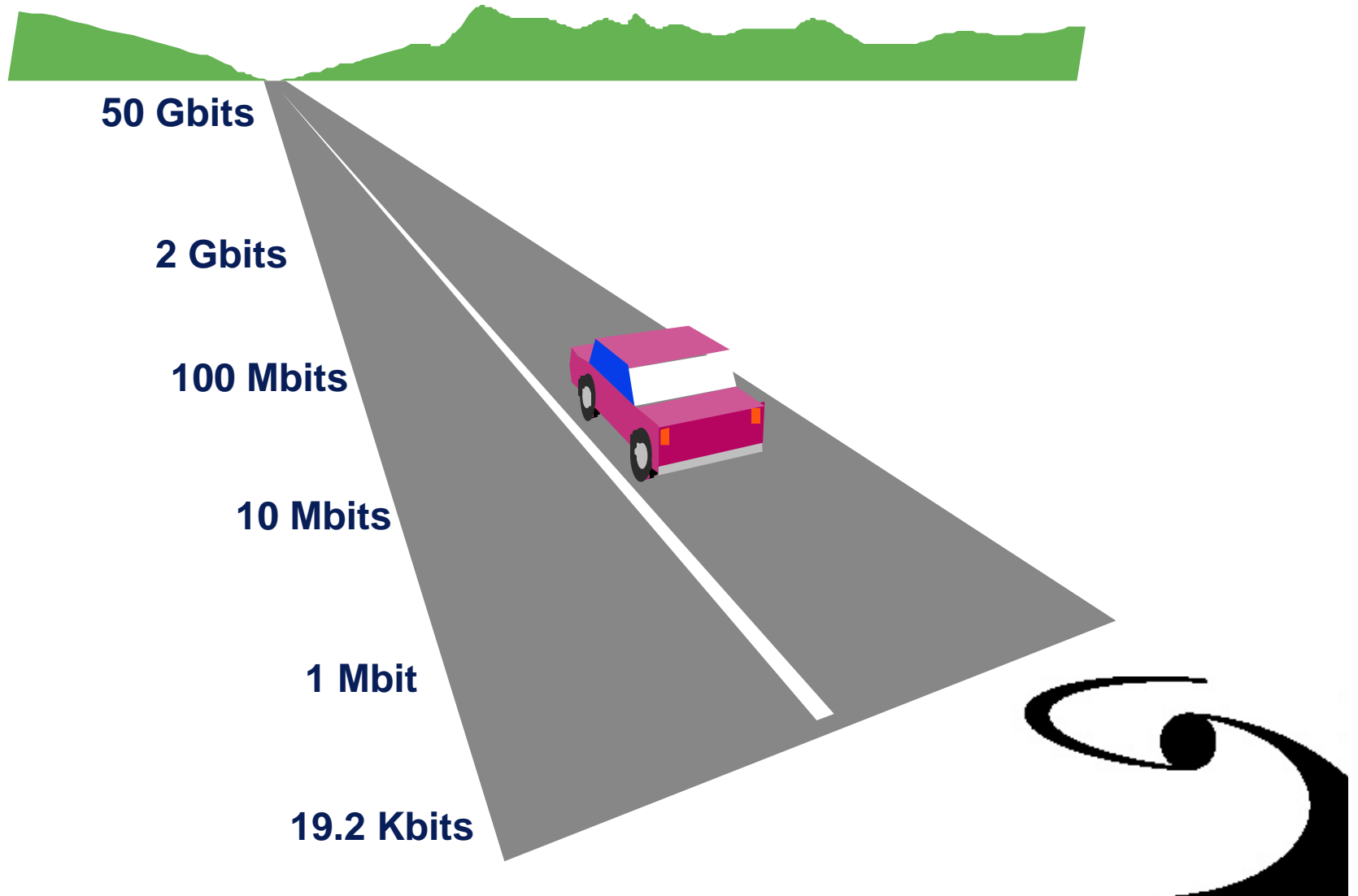

Future Proofing Copper

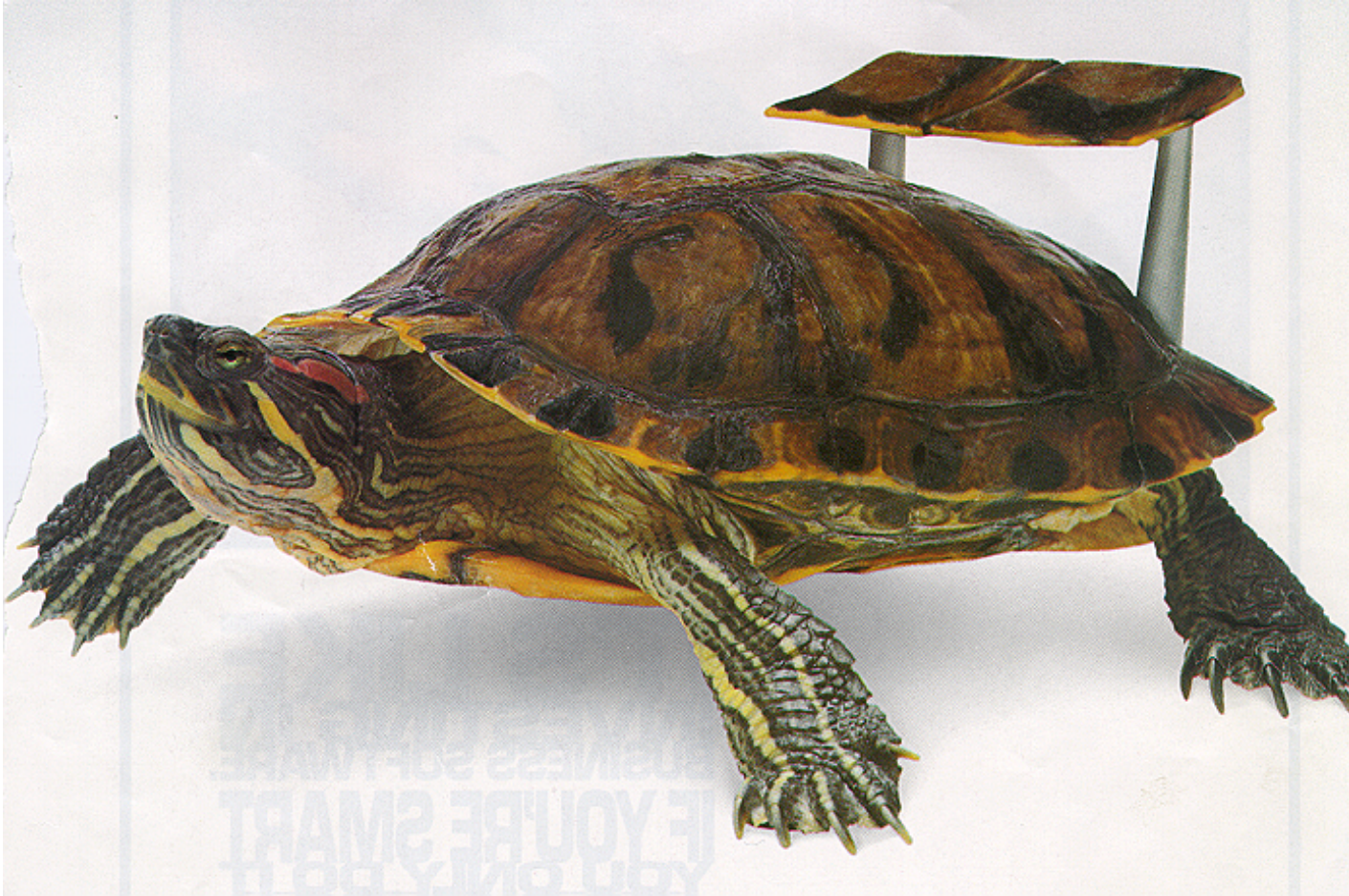

3M Volition™ Cabling System

Current Concerns

Issues with current cabling products

◆ COPPER

- Lifetime Costs
- Installation Quality
- Bandwidth Limitations
- Crosstalk, EMI
- Cable Volume & Weight

→ Is it Future-proof?

◆ WIRELESS

- Cost
- Bandwidth
- Security
- Reliability
- New Technology

◆ PLASTIC OPTICAL FIBER

- Cost
- Bandwidth
- Attenuation
- Ease of Installation

→ Is it Future-proof?

◆ FIBER

- Component Cost
- Electronics Cost
- Ease of Installation
- “Dark Art”

→ Ideal, but not seen as cost effective....YET



Network Cost Sensitivity Issues

- Component Costs
- Electronics/Electro-Optics Costs
- Installation
- Testing
- Moves and Changes
- Lifetime (Maintenance)



3M FTTD System Challenges

- Minimize system Costs
- Minimize Installation and Required Skill level
- Meet Industry Standard performance requirements
- Have Familiarity of an RJ45 Connector
- Compatible with standard glass optical fiber
- Comparable labor cost to UTP copper
- Field mountable in less than 2 minutes
- Compatible with standard test procedures
- Copper network as cost benchmark



Volition , Low Cost, Small Form Factor Optical Interconnect Proposal - System Solution

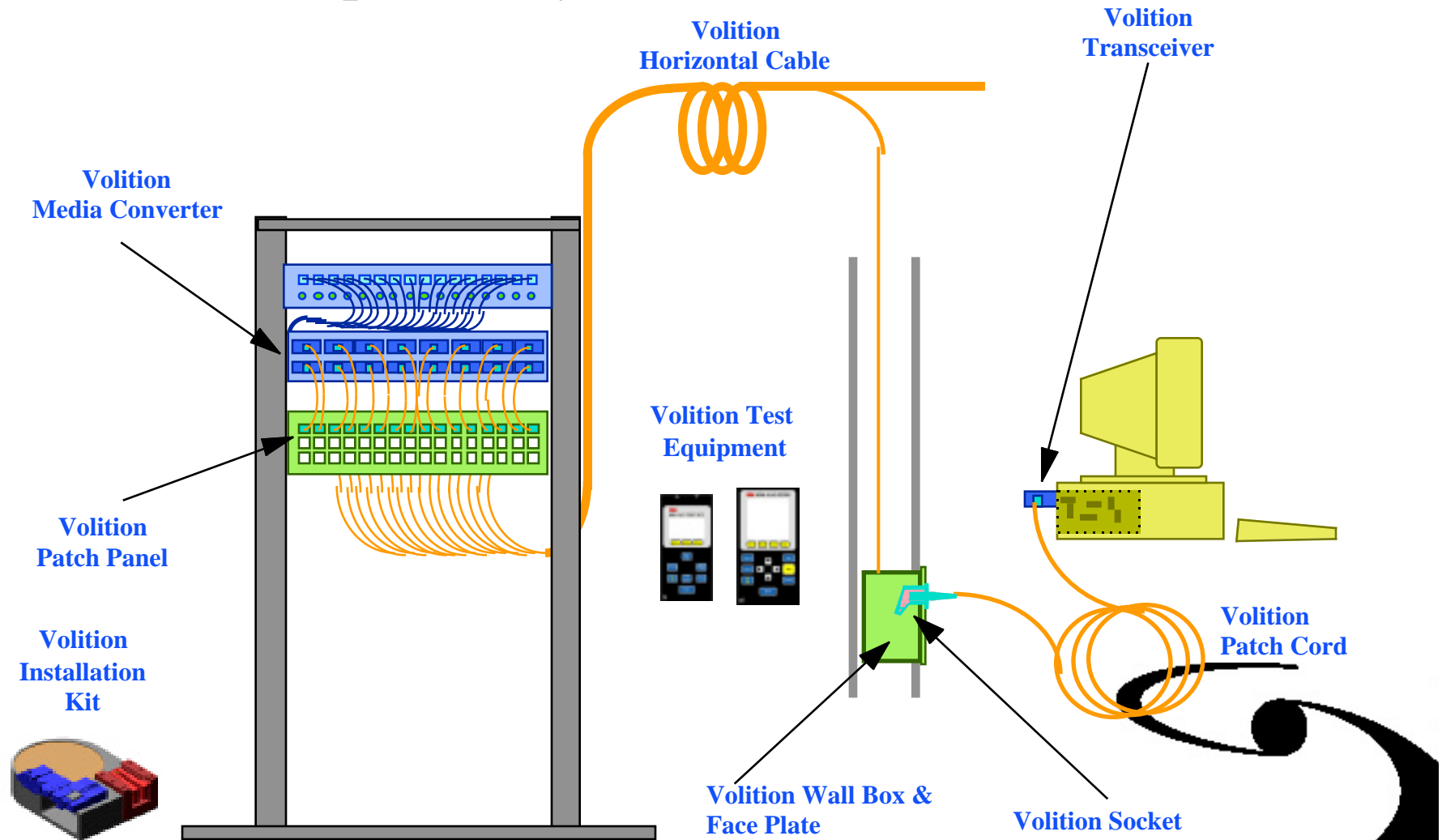

VF-45 Low Cost Duplex Fiber Optic Connector -1394b

- Fits 1394b Criteria:
 - Low Cost, Simple Installation, low loss (TIA compliant)
 - Suitable for Home Wiring with 20year lifetime
 - Standards Activity
 - Low to zero maintenance
 - Duplex, asymmetric, differentiated (keying)
 - Supports speeds from 125MBaud up to 4GBaud
 - Suitable for equipment, dongles and wallplates
 - Supports Multimode GLASS Optical Fiber
 - 50 micron & 62.5 micron
 - * Except POF due to many uncertainties/variables
 - One cabling solution for any bandwidth
 - EYE Safe



VF-45 Low Cost Duplex Fiber Optic Connector -1394b

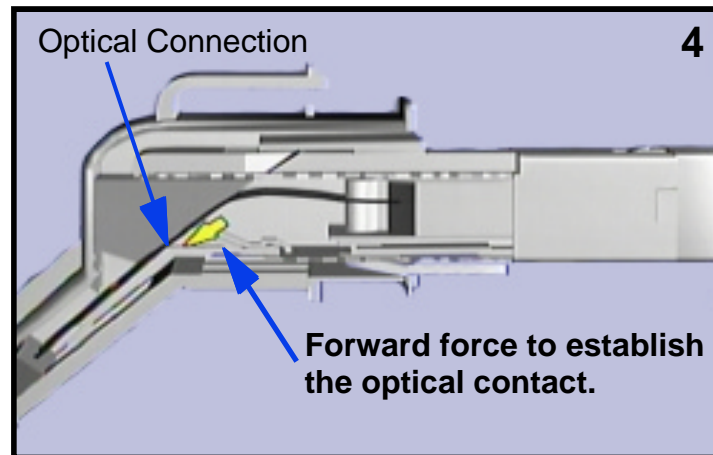
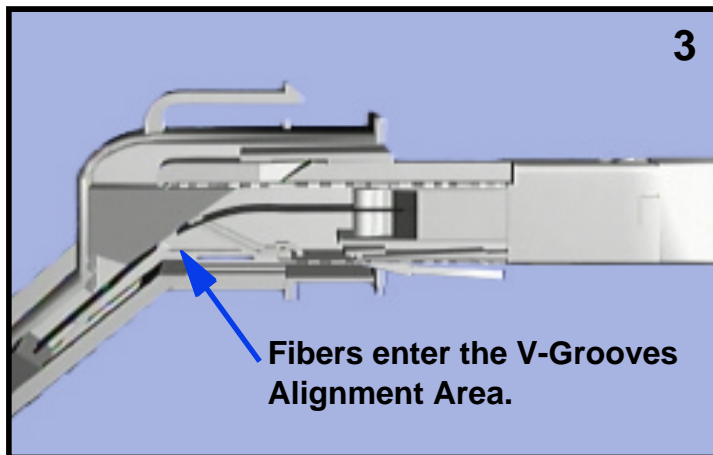
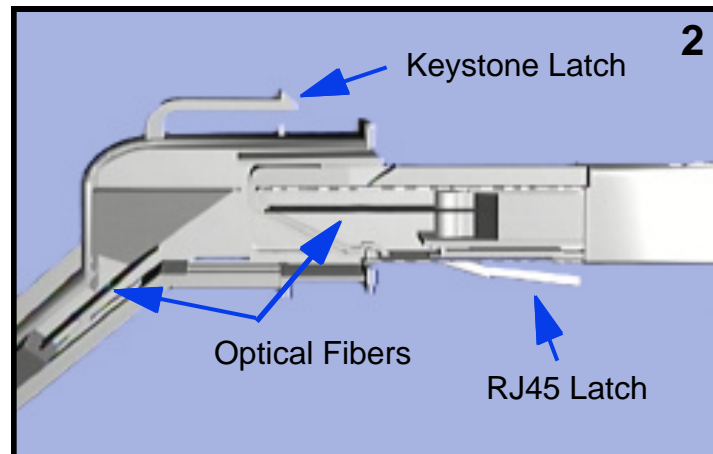
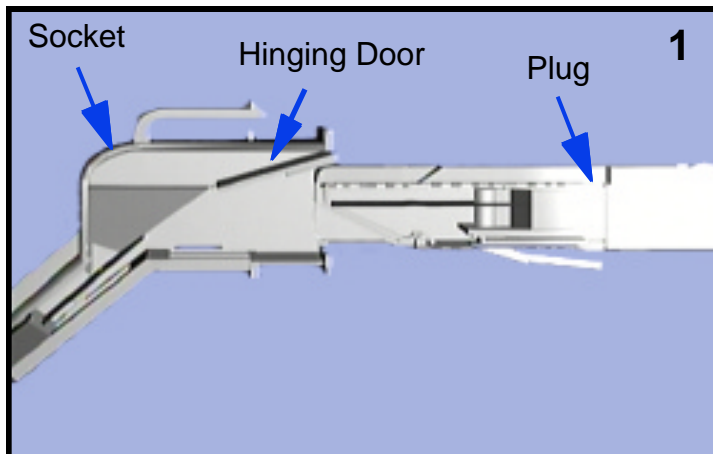

VF-45 Low Cost Duplex Fiber Optic Connector -1394b

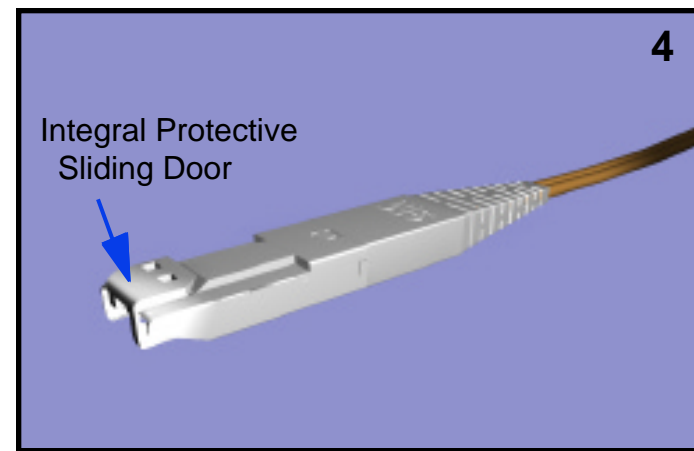
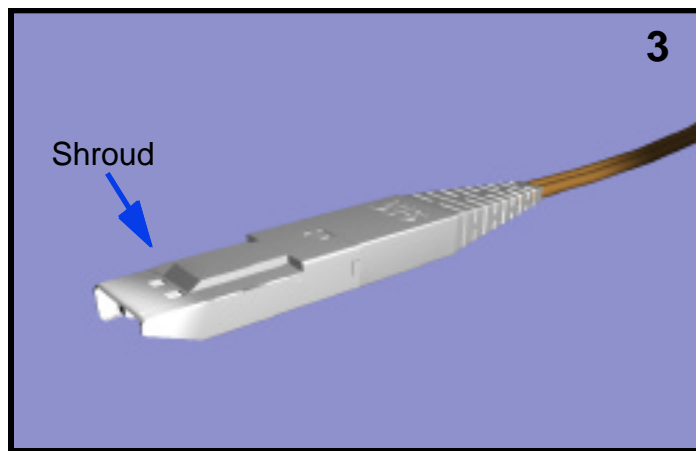
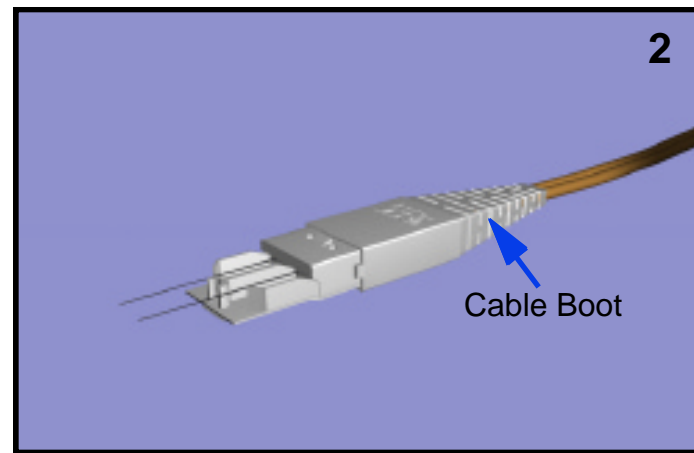
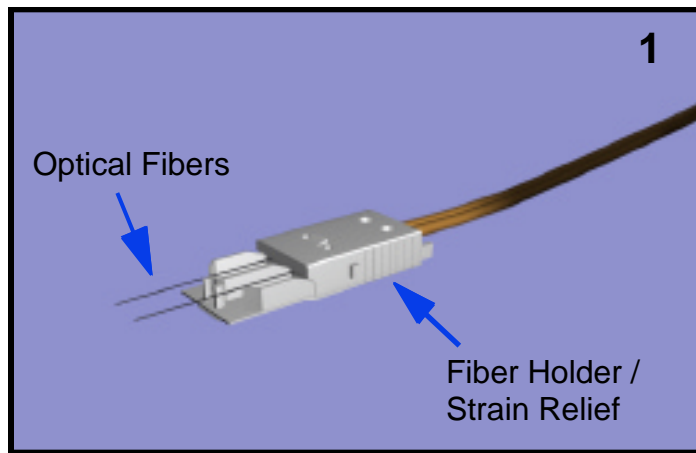

VF-45 Low Cost Duplex Fiber Optic Connector -1394b

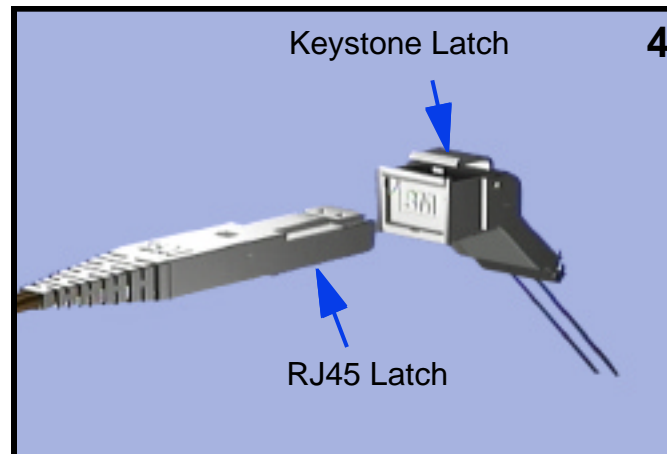
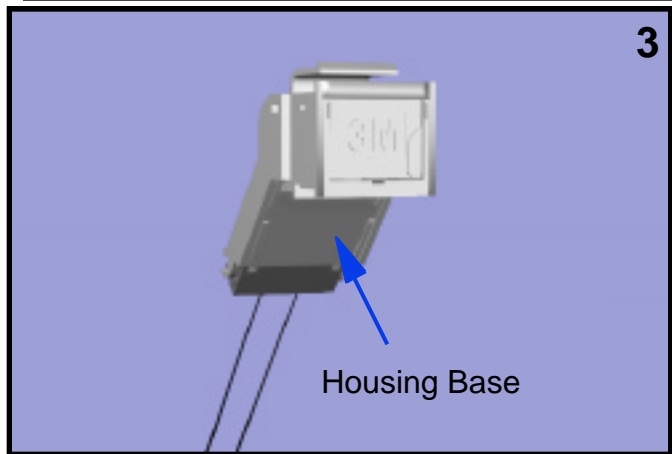
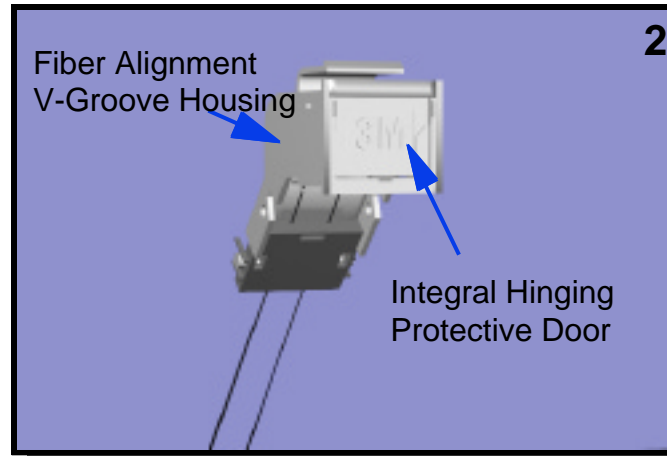
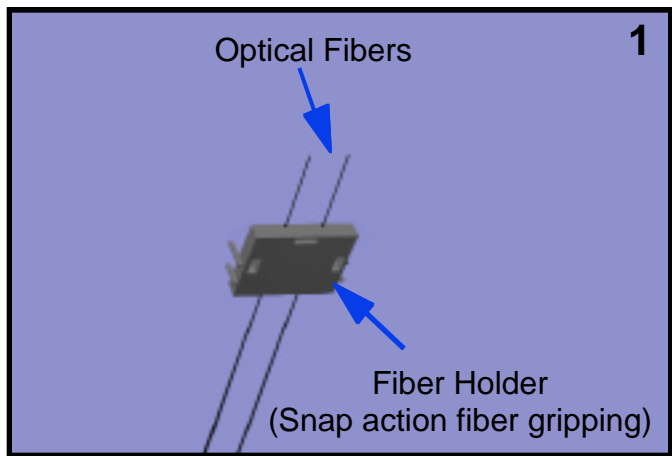

VF-45 Low Cost Duplex Fiber Optic Connector -1394b

- Advantages over Standard SC:
 - Significant improvement over SC
 - Low cost (50% of SC)
 - Sub-assembly components
 - Installation labor
 - Small Size (50% of Duplex SC)
 - High density footprint
 - Duplex / Polarized



VF-45 Low Cost Duplex Fiber Optic Connector -1394b

- Performance - ISO 11801; TIA-568A
- All source technologies
- Dust and Eye protection
- Licensing per ANSI requirements



VF-45 Low Cost Duplex Fiber Optic Connector -1394b

“Performance Requirements”

Requirement	ISO/IEC 86B	TIA/EIA FO-6.3	Test Method
Attenuation	0.75 dB Max	0.75 dB Max	IEC 1300-3-4
Return Loss	- 20 dB	- 20 dB	
MM	-26 dB	-26 dB	
SM	500	500*	
Mating Durability			IEC 1300-2-2
Engagement/Separation Force	Simplex <i>20N</i> Duplex <i>40N</i>	None None	IEC 1300-3-11
Impact	5 Drops @ 1 m	8 Drops @ 1.5 m	IEC 1300-2-1
Cable Retention	50N @ 0°, Active	33N	IEC 1300-2-4
Side Pull	5N @ 90°, Active	6.6N @ 0°, Active	IEC 1300-2-4
Strength of Coupling	40N, Active	33N	IEC 1300-2-6
Flex	5N, Active	5N	IEC 1300-2-x
Torsion	None	15N @ 0°	IEC 1300-2-5
Cold	-10°C/96 hr., Active	-10°C/96 hr., Active	IEC 1300-2-7
Heat	+60°C/ 96 hr., Active	+60°C/96 hr., Active	IEC 1300-2-18
Humidity	+40°C/90-95% RH 96 hr., Active	+40°C/90-95% 96 hr., Active	IEC 1300-2-19
Thermal Cycling	x5 of -10°C/60°C Active	None	IEC 1300-2-22
Vibration	10-50-10 Hz, Active	None	IEC 1300-2-1

Note: Italic Indicates That The Corresponding Values Are Being Revised

* Rev1. 8/01/96

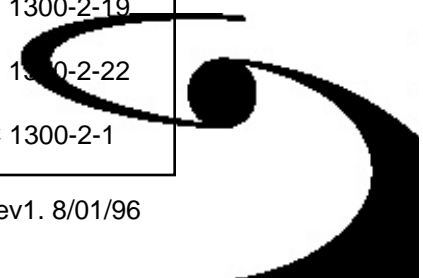

Current Connector Standard

- Duplex SC
 - 2.5 mm simplex ceramic ferrules
 - Simplex SC connectors w/duplex clip
 - Push - Pull
 - Same size / density as ST-style
 - High Cost



Ceramic Ferrule

X-Y-Z Fiber Alignment

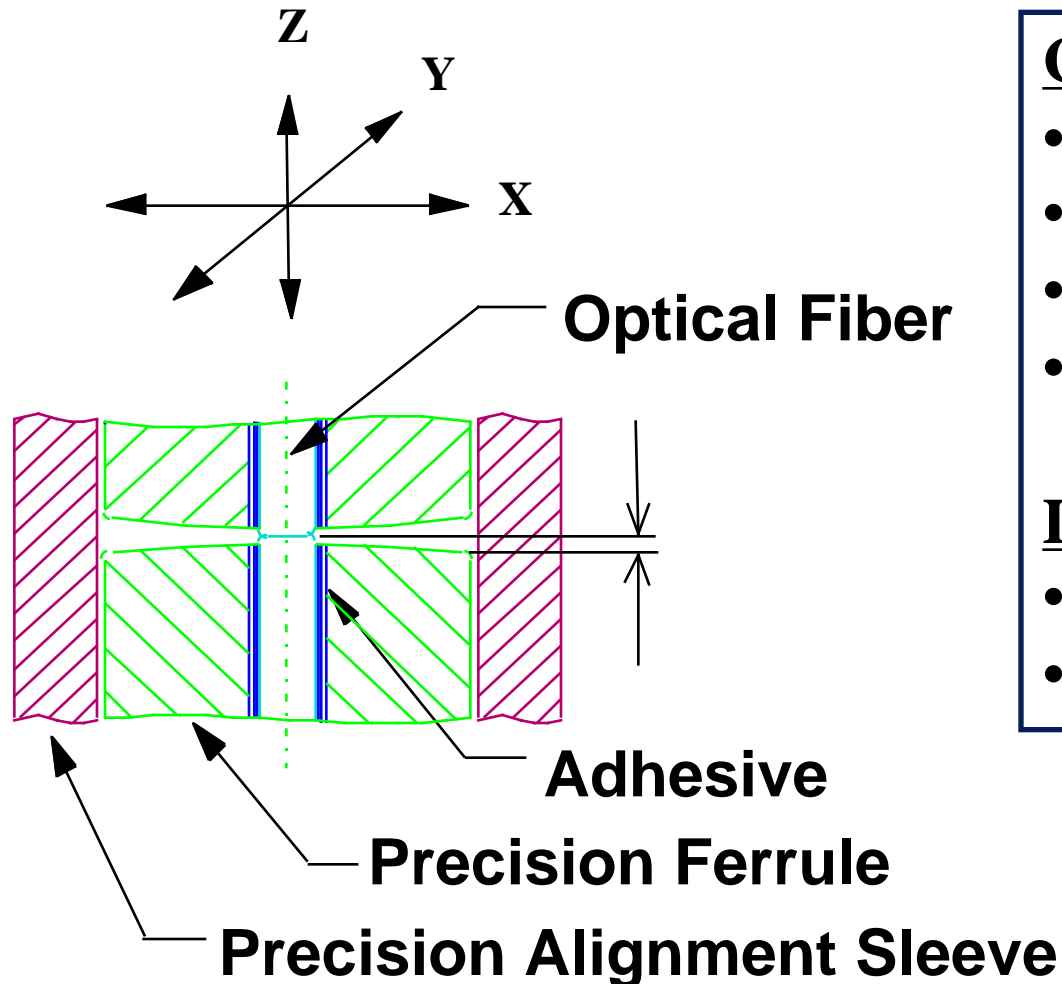

Concentric Components

- Core to Cladding
- Fiber to Capillary
- Capillary to Ferrule OD
- Ferrule OD to Sleeve

Length Components

- End Face Polish
- Spring Pressure

Single Ferrule / Duplex X-Y-Z Fiber Alignment

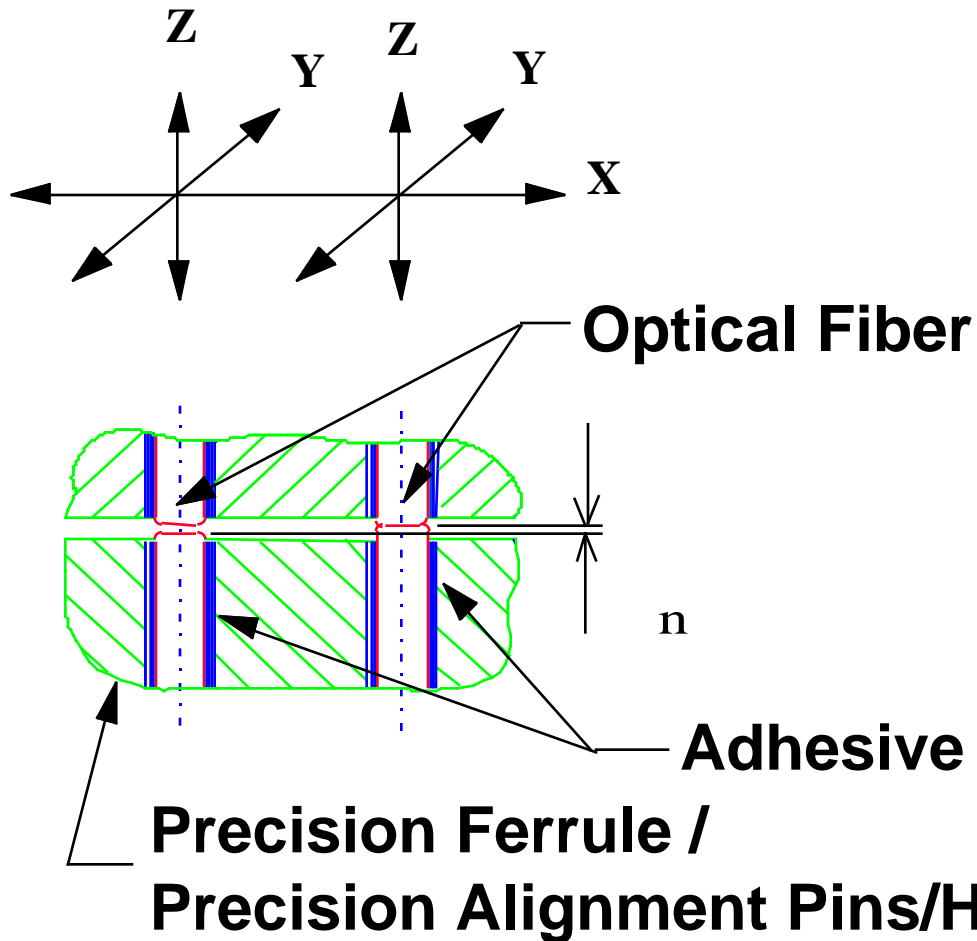

Concentric Components

- Core to Cladding
- Fiber to Capillary
- Capillary to Capillary
- Capillary to Ferrule OD
- Ferrule OD to Sleeve
- Pin Alignment

Length Components

- End Face Polish
- Spring Pressure

VF-45 “Ferrule-less” V-Groove Technology

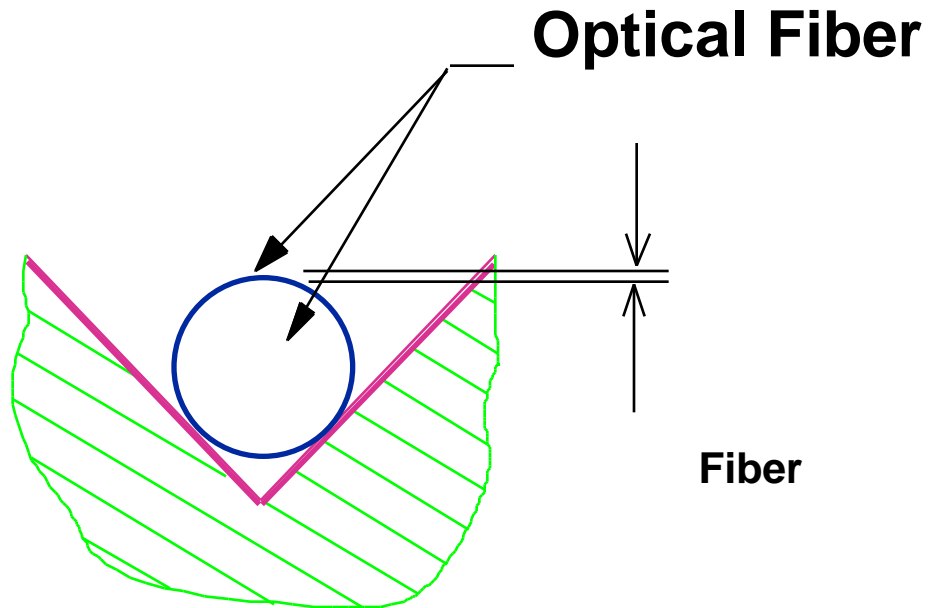

Concentric Components

- Core to Cladding
- Fiber OD to Fiber OD

Length Components

- Minimal

Optical Performance:

Self Alignment of Optical Fiber

Typ. Tolerance: Multi Mode - 3 μm

Single Mode - 0.8 μm



VF-45 Low Cost Duplex Fiber Optic Connector -1394b

“V-Groove Fiber Alignment”

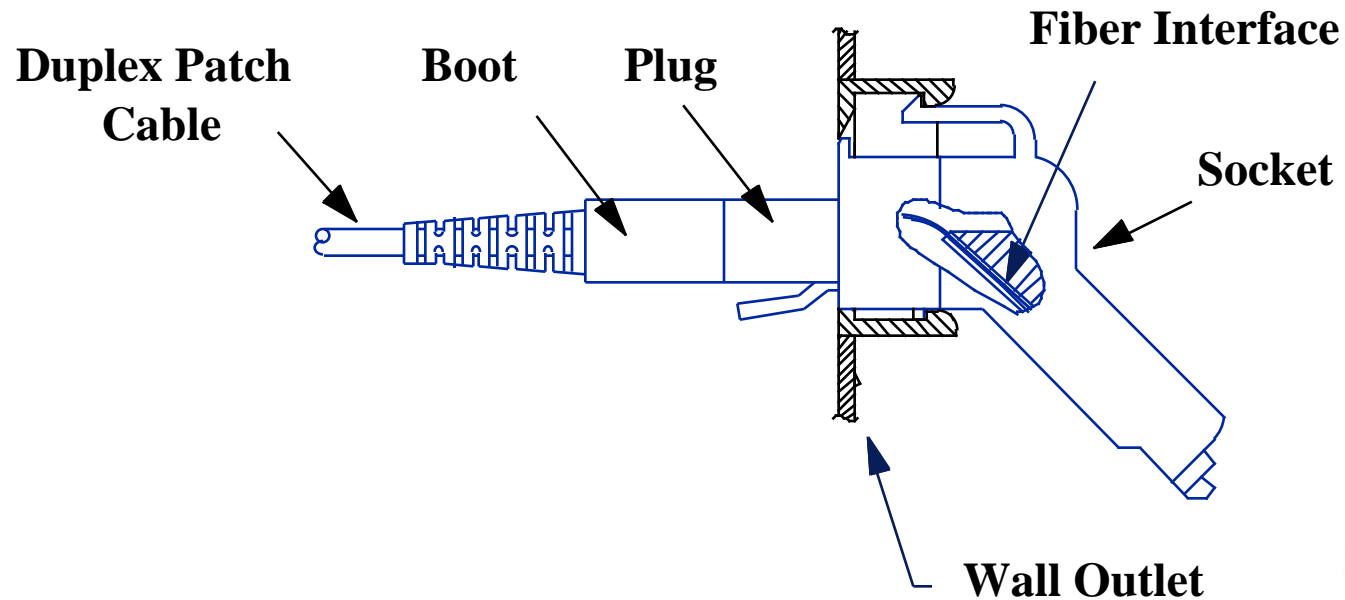

VF-45 Duplex Fiber Connector vs. Duplex SC

- Reduced Cost
 - A few molded plastic parts
 - No precision ceramic ferrules
 - No collars or springs

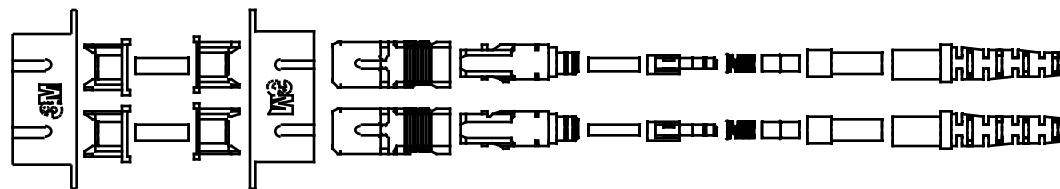
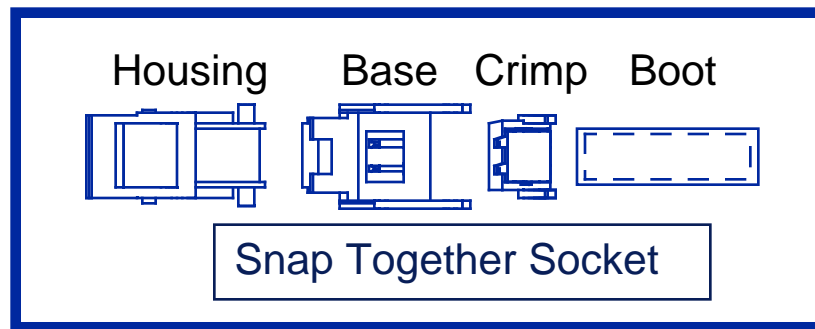
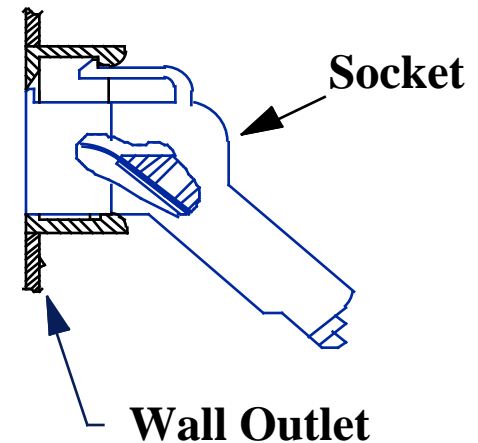

CURRENT SC CONFIGURATION

VF-45 Low Cost Duplex Fiber Optic Connector -1394b

- Proposed Cost:
 - Elimination of ALL precision components (Ferrules/Sleeves)
 - Elimination of Alignment coupling/adapter
 - Minimum component count
 - Readily available materials
 - Transferable technologies (injection molded)
 - Elimination of adhesives and corresponding accessories
 - Simplicity and efficiency of installation



VF-45 Low Cost Duplex Fiber Optic Connector -1394b

- Ease of installation
 - Duplex fiber installation
 - Prep and terminate two fibers at one time
 - Minimal tools required
 - Minimize number and cost of tools
 - Minimal handling of bare fibers
 - Safety, Yield and cleanliness



VF-45 Low Cost Duplex Fiber Optic Connector -1394b

- Ease of Installation & Testing
 - Glass Fiber Optic Cable is Robust
 - Pull-strength rating: 160 pounds
 - TIA 568-A Building Cabling Standard for UTP recommended at 25 pounds
 - Labor to install fiber optic cable and UTP is comparable
 - Approved TIA-526-14 test procedures for Glass Optical fiber are available



Transceiver Package V-Groove Fiber Alignment

- Cost reduced E/O device into single package
 - Improves density

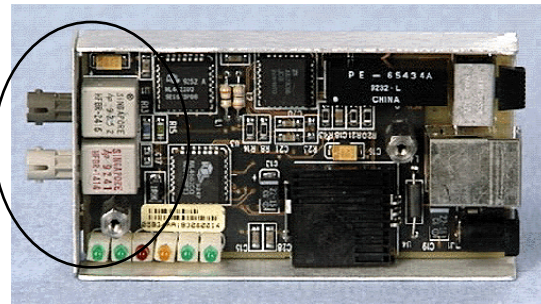
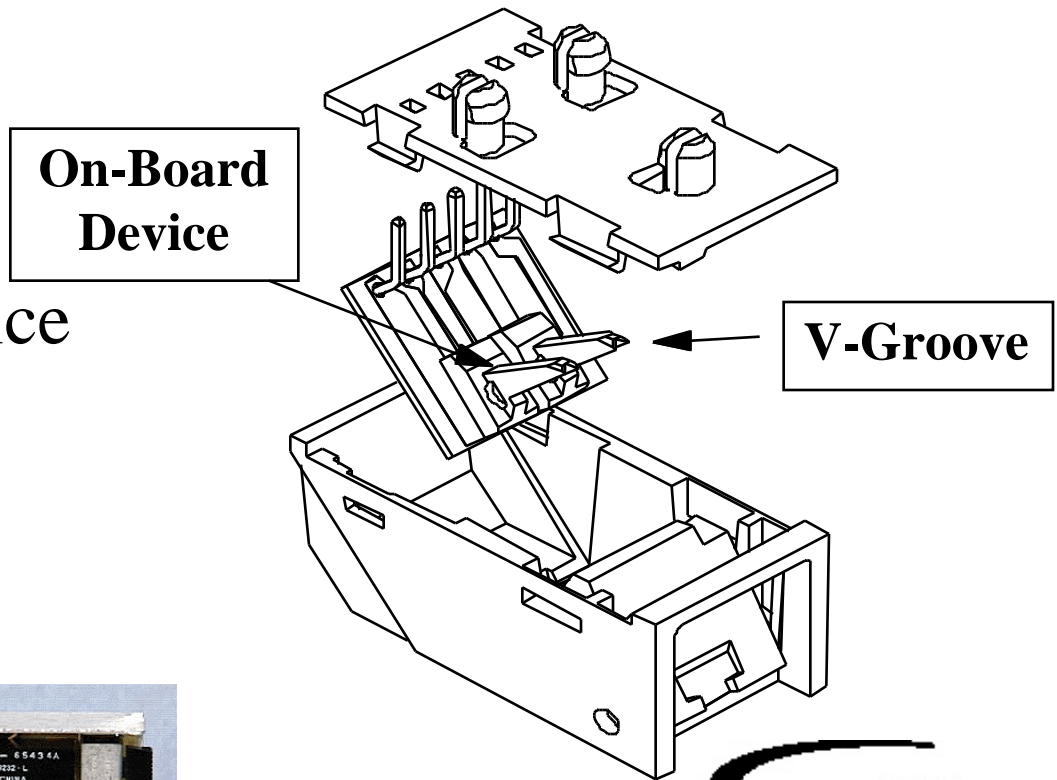

V-Groove Technology and Transceiver Cost

- Reduced alignment complexity
 - Duplex fibers align direct to devices
 - Packaging automation
- High density
 - Same as RJ-45
 - Equal # of ports as copper in electronic hubs
 - Half the size of duplexed SC
- Reduces cost of terminal equipment
- Drives horizontal fiber toward cost parity to copper

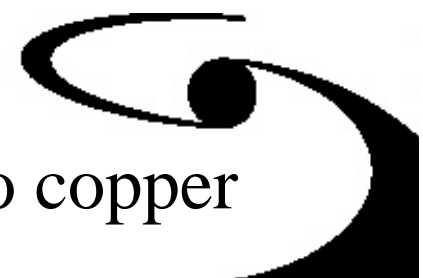

VF-45 Low Cost Duplex Fiber Optic Connector -1394b

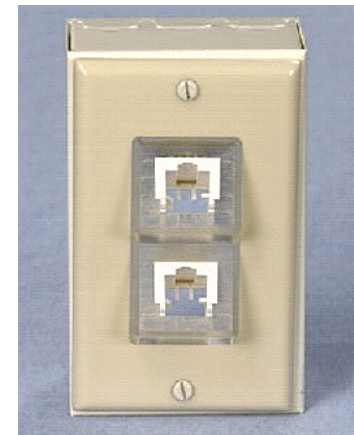
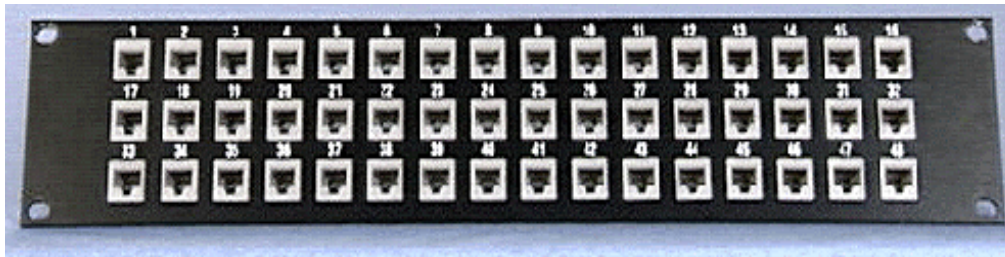
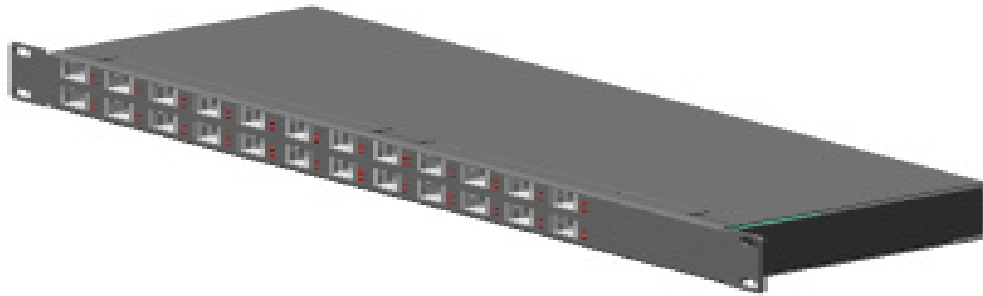

VF-45 Low Cost Duplex Fiber Optic Connector -1394b

- Supports VCSEL Technology
 - Higher transmission speeds on standard MM fiber (50um)
 - 2 to 3 GHz/km without special signal launch
 - Possible 6 to 10 GHz/km with special signal launch
 - Low cost transmitter for high speed
 - Low EMI even at high density applications
 - Low power needs 10-15% of LED's



VF-45 Low Cost Duplex Fiber Optic Connector -1394b

Summary

- Low cost solution to standard optical connectors
- V-Groove technology offers cost reductions
 - Elimination of precision components
 - Ferrules
 - Reduced labor of installation
- High density transceiver in copper footprint
- Amateur Installation



VF-45 Low Cost Duplex Fiber Optic Connector -1394b

- Vision for Home Application:
 - Parts readily available at places like:
 - Home Depot, Radio Shack, Distributor counters etc....
 - Termination kit to be low cost i.e. throw away
 - Fewer parts
 - Any one can install/terminate
 - Just like installing a phone jack today
 - VF-45 Home Kit will be designed minimal installations
 - Current kit designed for large installations



VF-45 Low Cost Duplex Fiber Optic Connector -1394b

- Availability
 - Over 14 Alpha and Beta trials TODAY
 - Production release January 1998
 - Standards activity ongoing
 - Networking
 - ATM, Fibre Channel, Ethernet Gigabit, 10/100
 - Cabling
 - TIA-568A, ISO 11801, CENELEC, TR41
 - Will be pursuing TIA-570 Residential Cabling
 - Components
 - IEC

