

Distribution System Static VAR Compensators: Field Experience

Ray Kemerer

Power Quality Systems, Inc.

February 4, 1998

IntelliVAr Advanced Static VAr Compensator (ASVC)

Block Diagram

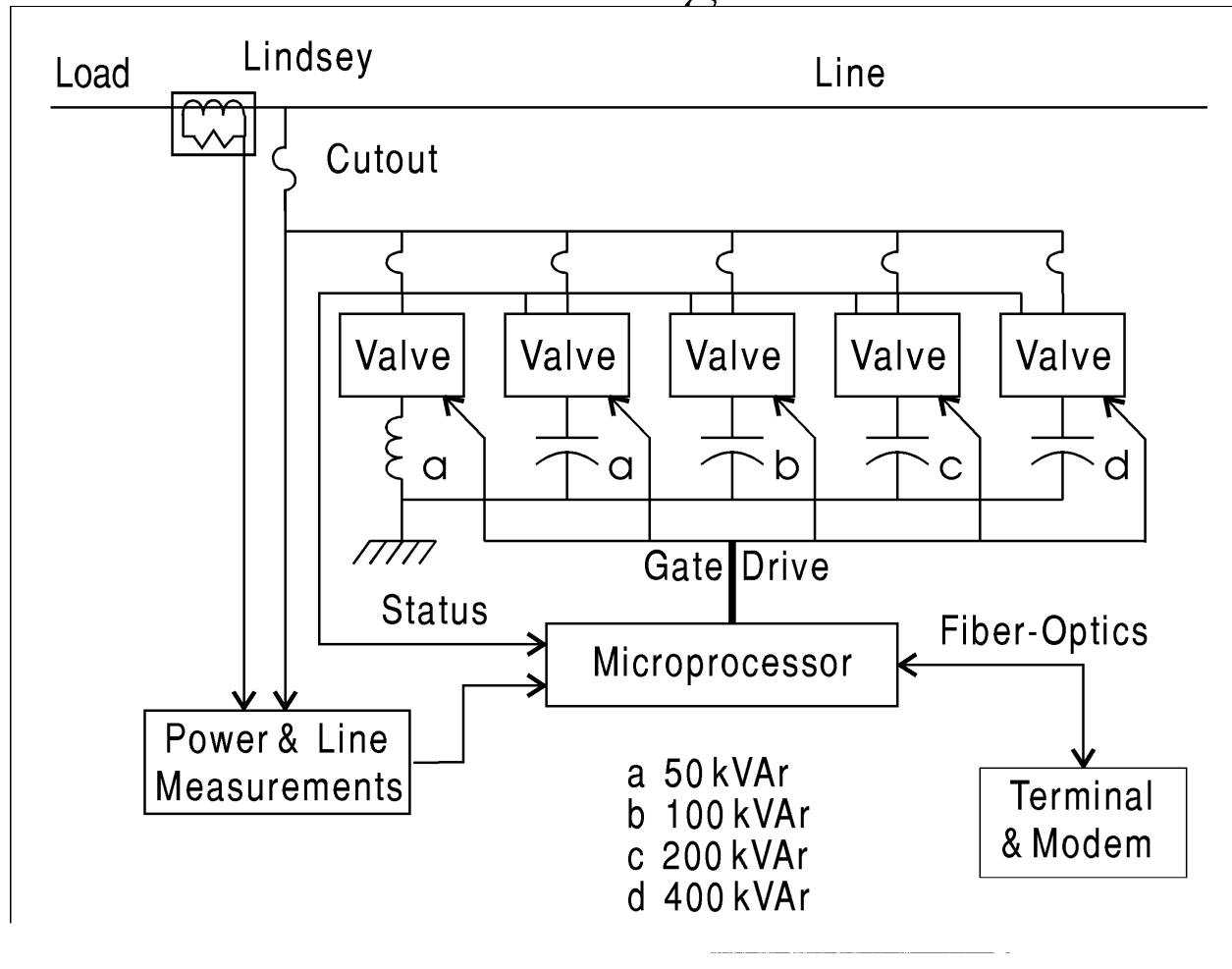

Some Typical ASVC Applications

- Lumber/Paper Mills
- Arc Welders
- Arc Furnaces
- Large Motor Loads
- Large Power Supplies
- Pumping Stations

Typical ASVC Specifications

- Frequency: 50 Hz or 60 Hz
- Voltage: 7200 to 7967 volts line to neutral (directly connected)
- 95 kV BIL
- -40° to +40°C
- 2500 lbs. (1100 kg)
- Applied kVAr Capacity: 100 lagging to 1000 leading per phase
- Stepless Control
- Dimensions: 85 (216) x 51 (130) x 47 (119) inches (cm)

Requirements for Installation

- Install Platform (not required if pole-mounted).
- Install “load break” cutout for connection to ASVC line bushing.
- Replace pole top insulator with current sensor.
- Connect neutral to ASVC ground pad.
- Provide 200 VA, 120 volt service and telephone or cellular connection (for remote communication only).
- Installation does not cause customer service interruption.

Pole-Mounted Installation Detroit Edison



Pre-Installation Considerations

- Source and transformer impedance data
- Baseline load data such as harmonic content, power factor, and time duration of dynamic loads
- Modeling and simulation
- Installation type: pole, platform, or pad-mount

Actual vs. Modeled Power System

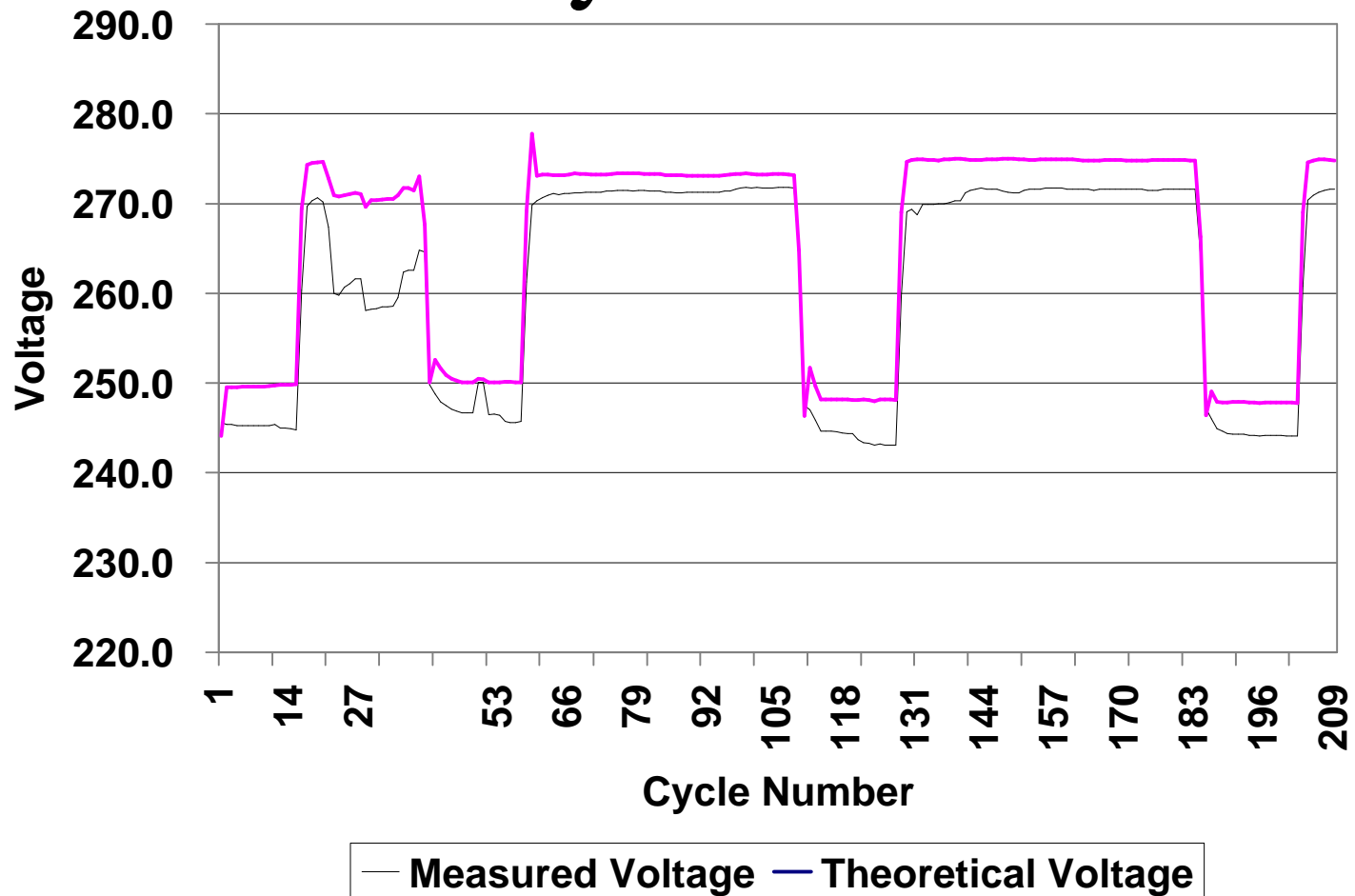

Predicted ASVC Response

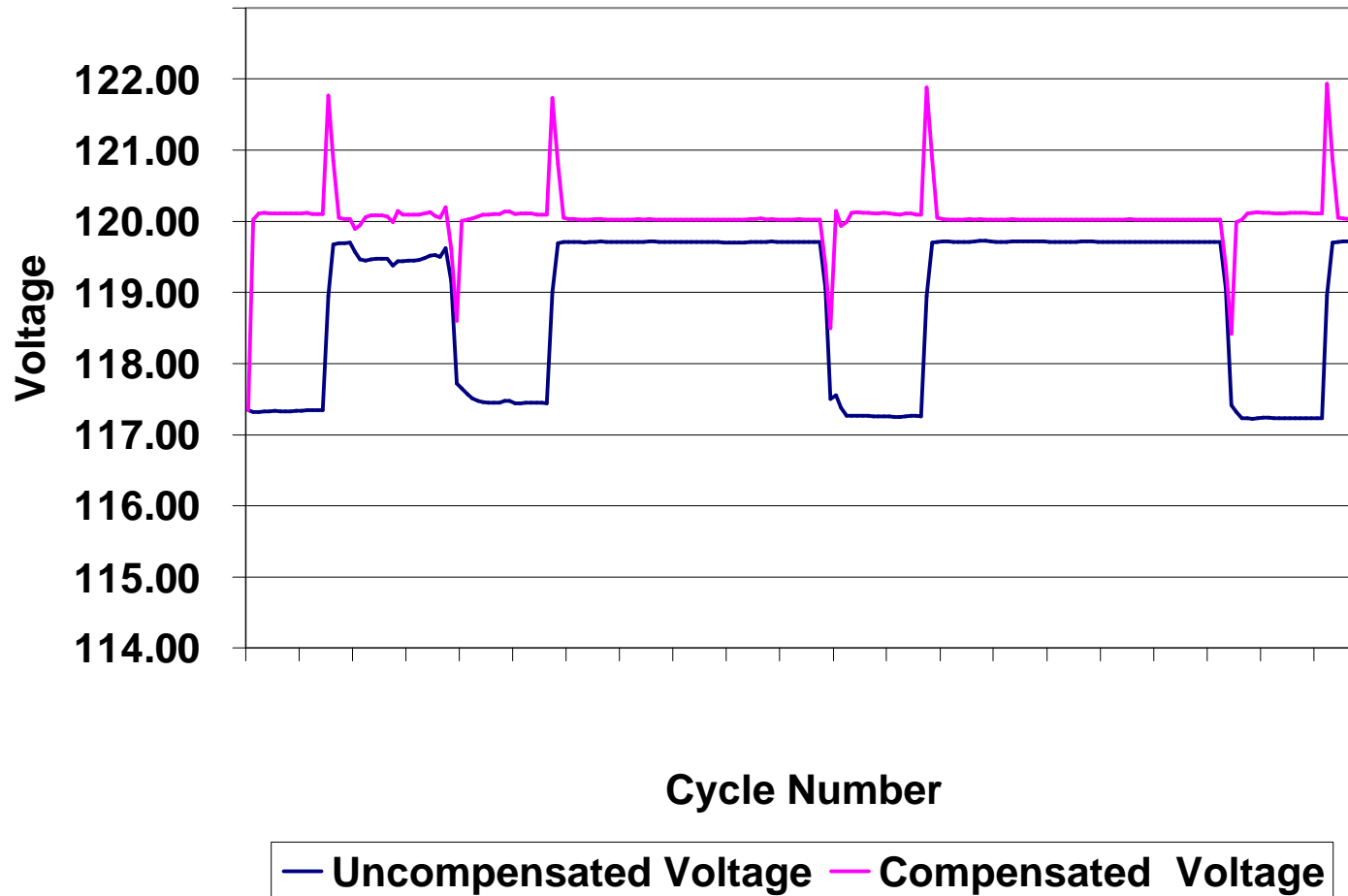

Oconee EMC (Ogelthorpe Power) Installation - Dudley, GA

- 7200 volt line to neutral rating
- 50 kVAr inductive to 650 kVAr capacitive per phase (stepless)
- Installed at highly automated Gilman Building Products plant (lumber mill)
- Motor load was generating flicker
- Gilman plant had motor failures and motor drive tripping
- Power factor ranged from .7 lagging to worse than .866 leading

Platform-Mounted ASVC System at Gilman Building Products Installed January 27, 1997



Improved Voltage Stability

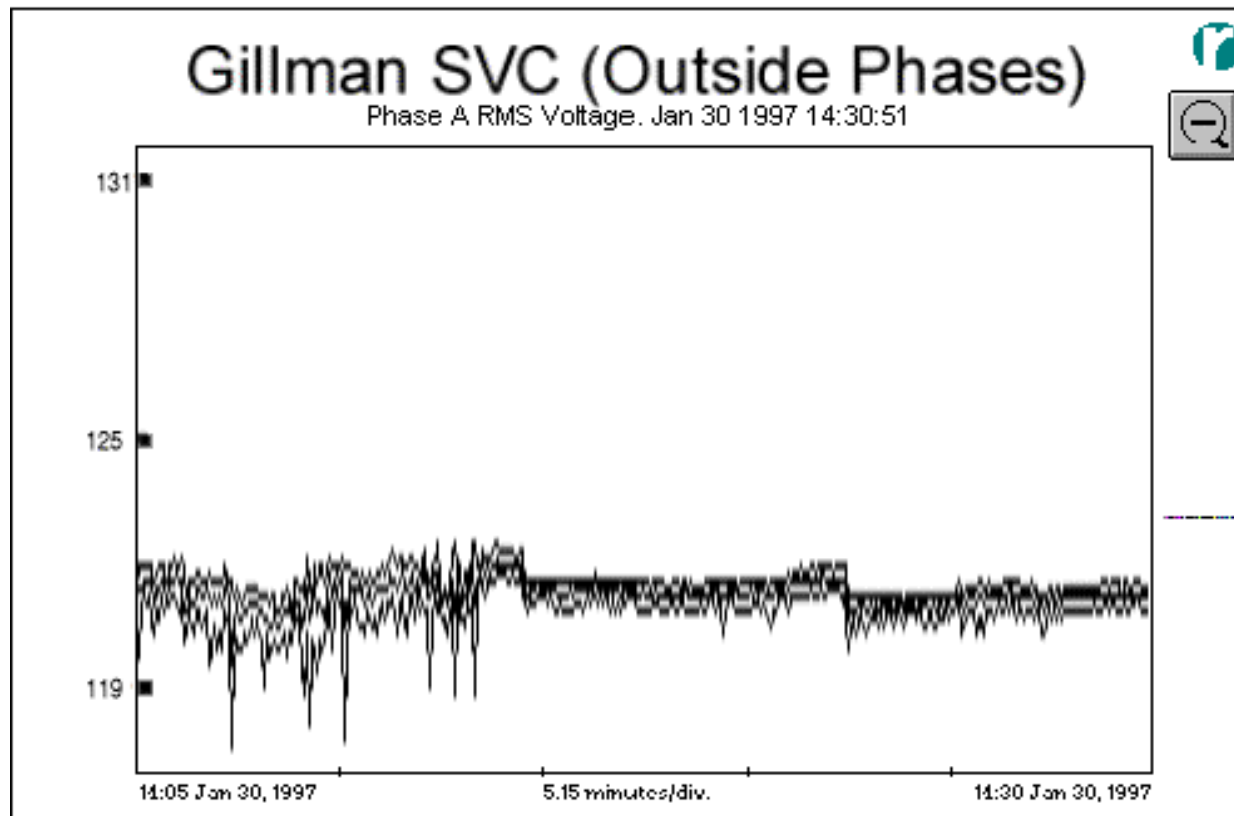

Conclusions - Lumber Mill Installation

- No customer motor failures in the year since installation
- Power factor improved to near unity during leading and lagging load conditions
- Improved power quality for Gilman and neighboring distribution customers
- Directly connected ASVC has been a reliable and effective solution.