*Field Experience with a Series
Compensation Device*

Stephen Middlekauff
IEEE PES July 14, 1998



Dynamic Voltage Restorer



Photo courtesy of Westinghouse

The Series Compensation Device (SCD)

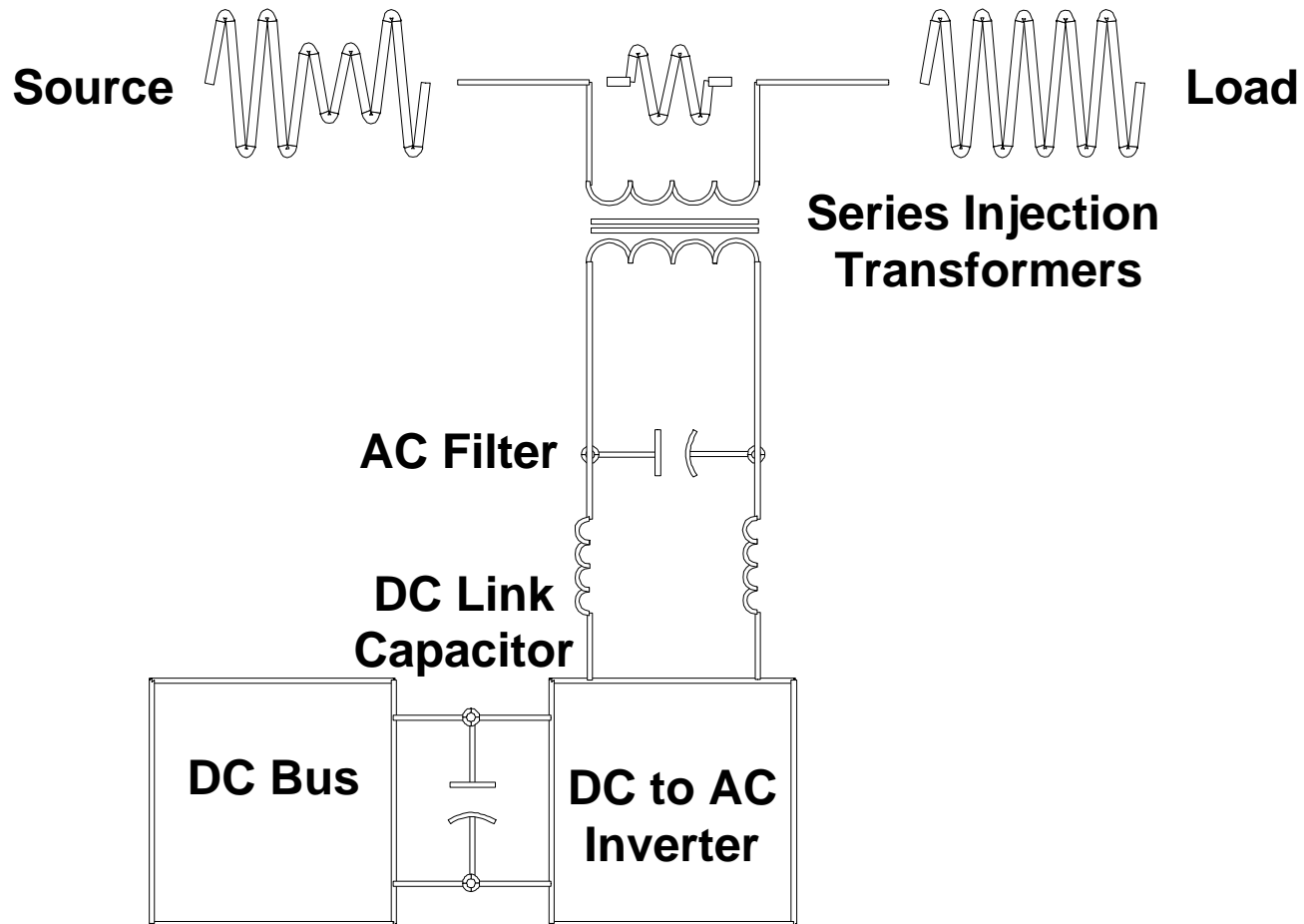

The Dynamic Voltage Restorer *(DVR)*

- **Westinghouse/EPRI/Duke Power tailored-collaboration**
- **50% Rated voltage injection**
- **Capacitor energy storage**
- **Installed to protect sensitive textile customer**

Field Experiences

- **Enclosure Issues**
- **Trailer vs. Enclosure design**
- **Grounding Issues**
- **Climate/Environment Issues**

Trailer vs. Enclosure Design

- **New Westinghouse design is fully enclosed**
- **Challenges with Trailer:**
 - **Tires**
 - **Support**
- **Added permanent supports**

Trailer vs. Enclosure (cont.)

- **Workability**
- **Ease of Access to components**
- **Safety**
- **Footprint**

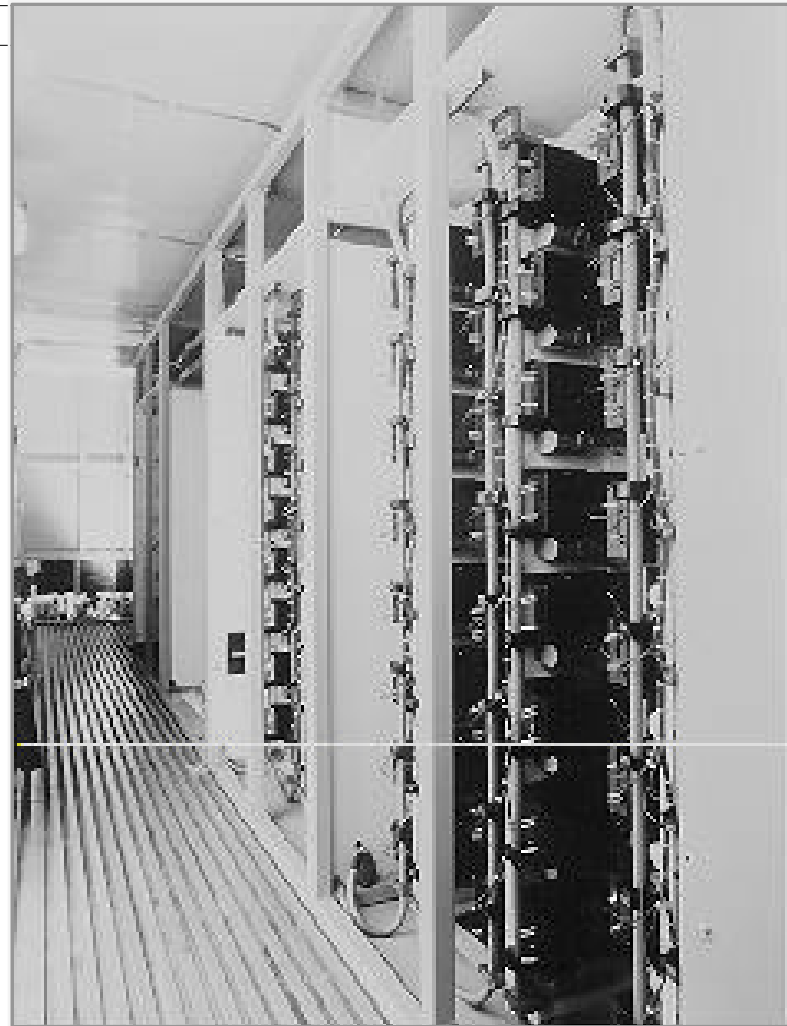

Photo courtesy of Westinghouse

Environmental Issues

- **Outdoors**
 - Must be air cooled
 - Air must be filtered
- **Pollen / dirt build-up**
- **Frequent filter changes necessary**
- **Created fault**
 - Wire tracked
 - Control Electronics Damaged
- **Periodic thorough cleaning necessary**

Grounding Issues

- **Requires 2-man DLT crew**
- **Frequent trips to site**
- **Safety considerations**



Remote Re-start

- **Feature added in 1997**
- **Solves problem of shortage of personnel available to re-start**
- **Helpful for nuisance tripping**
- **Safe and effective**

Dig-in (Downstream Fault)

- **DVR bypassed**
 - protected itself
 - did not feed fault

- **Phone line ramifications**

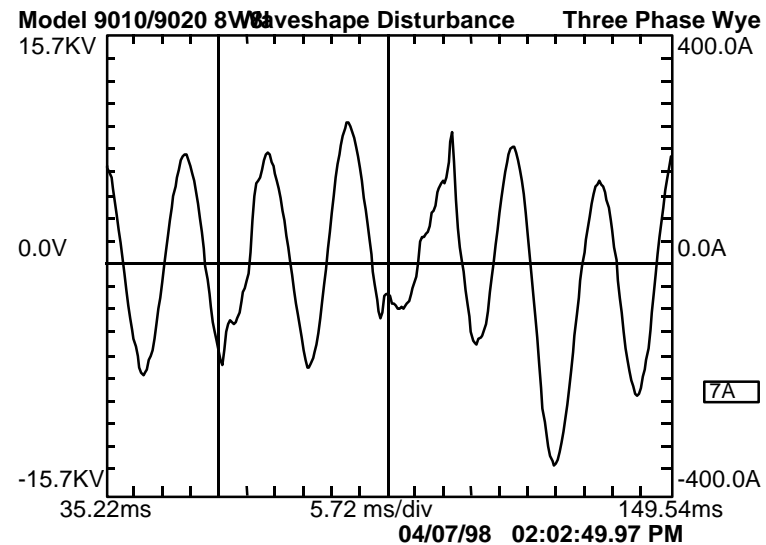
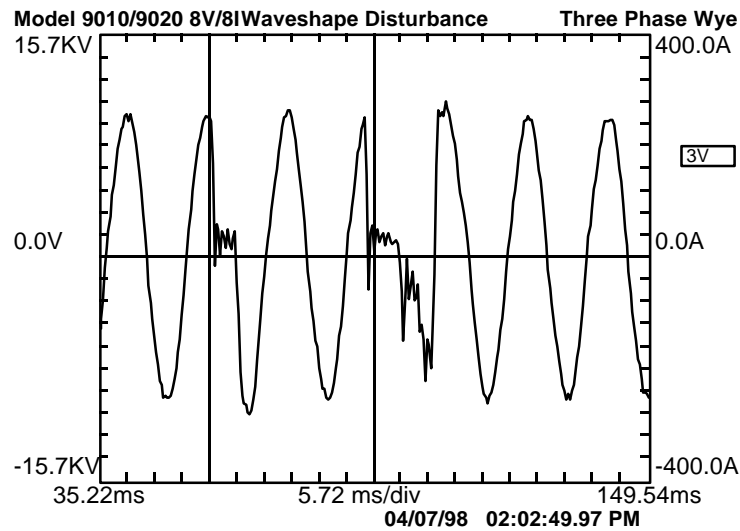

Customer Perception

- **Very Positive**
- **Increasing Confidence**
- **Realizing Benefit**
- **Higher Expectations**

Steady-state Voltage Imbalance

- Increased circuit load
- DVR improved from 2.1% to 0.7%
- Potential control power problem
- Three-phase regulators

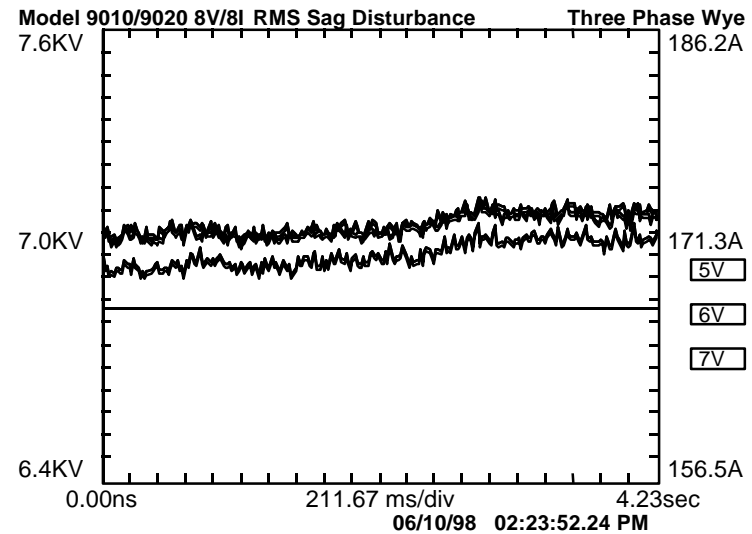
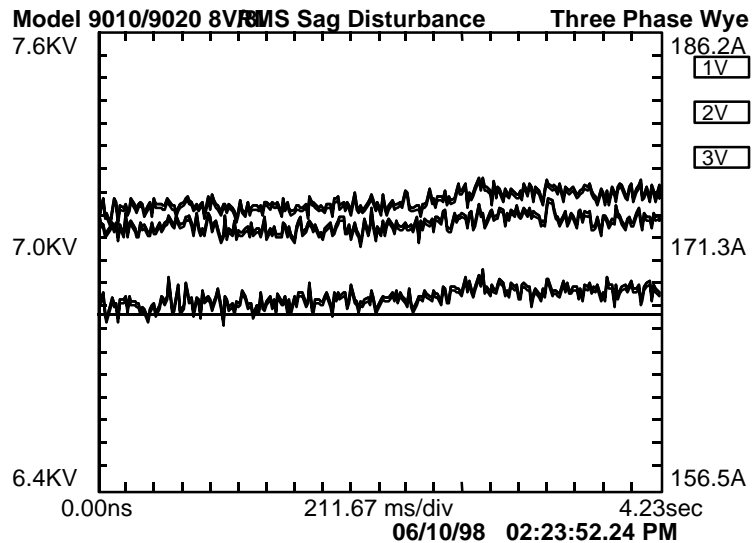

Waveforms

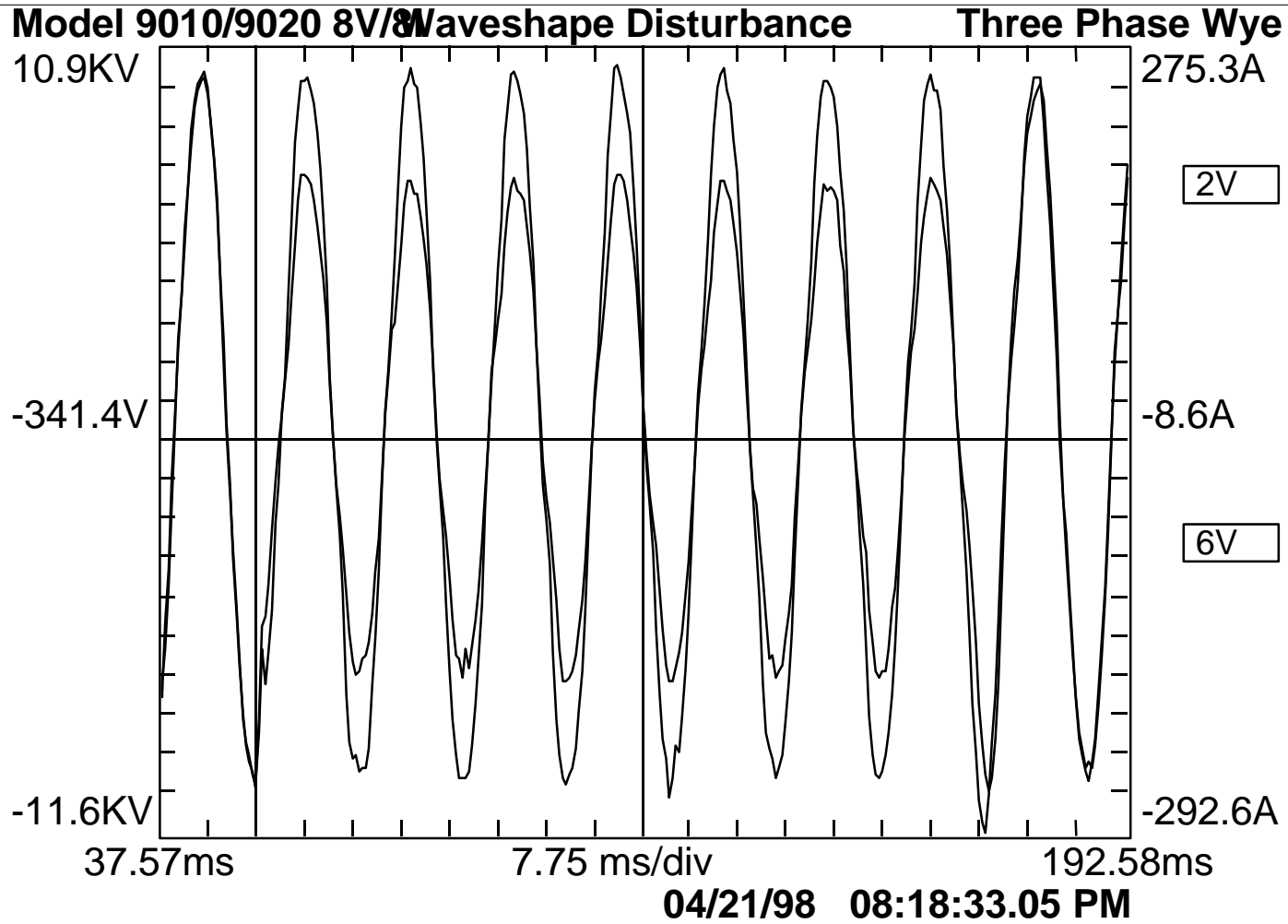

More Waveforms

Model 9010/9020 8W3a Waveshape Disturbance Three Phase Wye

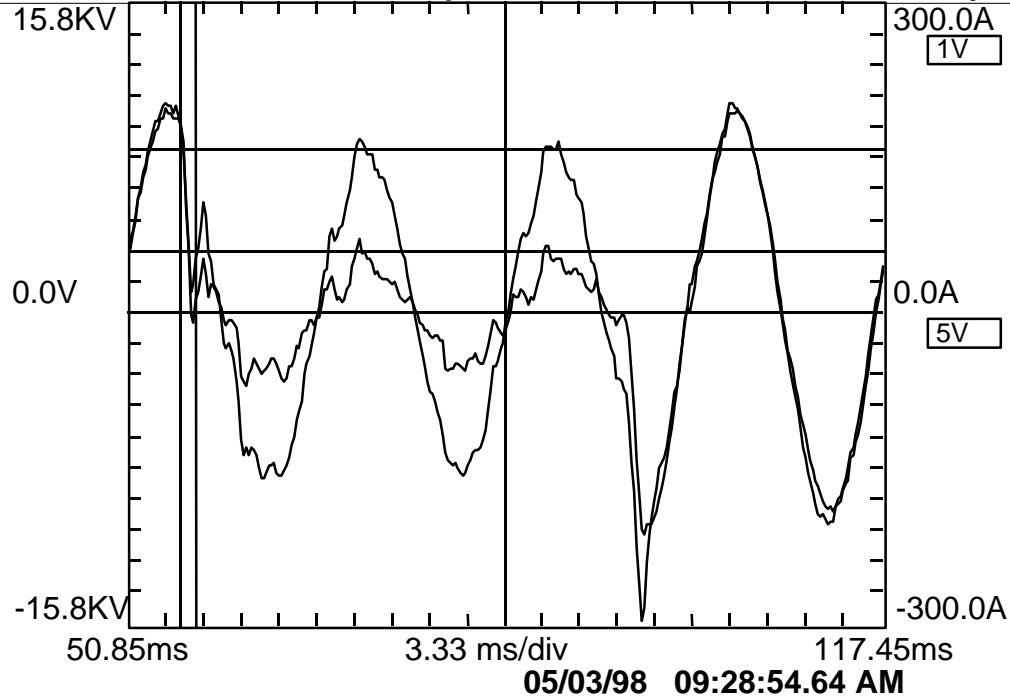

Channel	Y1	Y2	Delta
Voltage	8.361K	3.176K	5.185K

Channel	Y1	Y2	Delta

Time	X1	X2	Delta
	55.32ms	56.66ms	1.34ms (745.73Hz)

Even More Waveforms

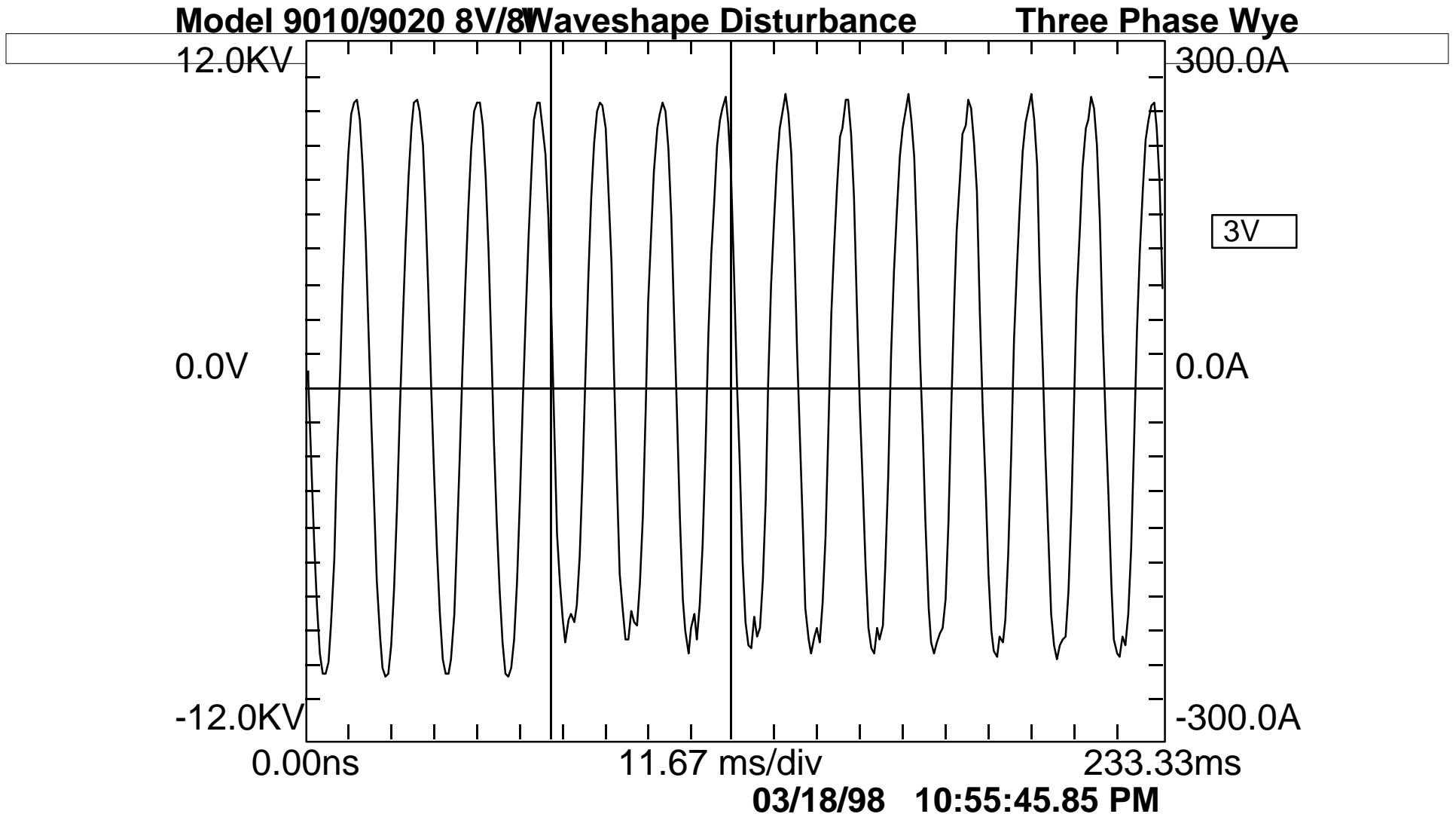

More Waveforms Still

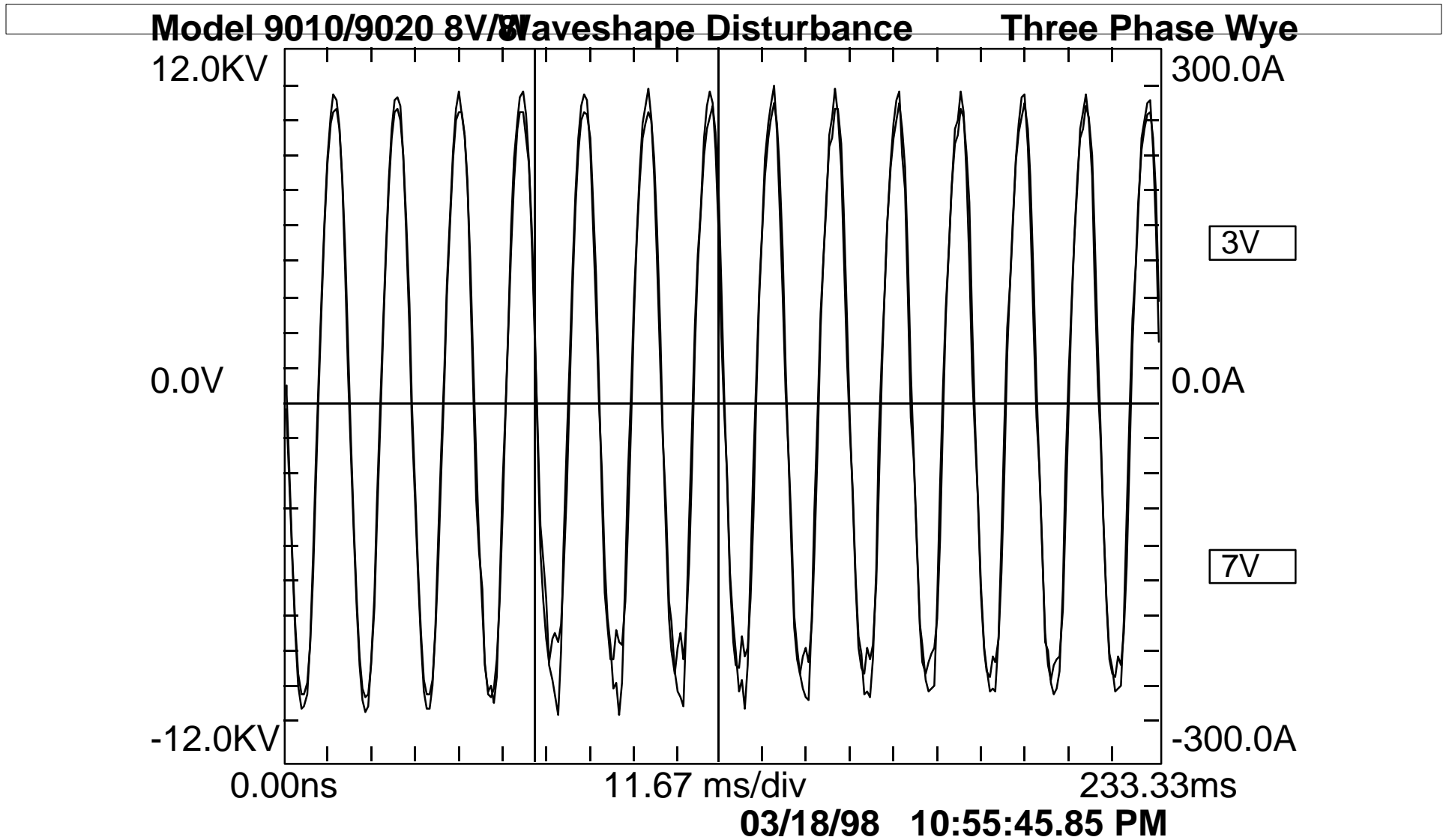

Performance Data

- **On-line to correct over 30 events in 1998**
- **Heavy storm season**
- **Availability still near 100%**
- **Continues to perform as designed**

More Performance Data

- **10 events caused process interruption in 1998**
 - 2 outages
 - 3 extended sags
 - 2 downstream faults
 - 1 DVR was off-line
 - 1 DVR corrected as designed (lightning)
- **DVR performed as designed on all but one event for 1998**

Future Plans

- **Will continue to protect at same location**
- **Extended maintenance contract**
- **Continue to monitor, learn, and gain experience**
- **Continue to satisfy customer**