

**A Proposal for IEEE P1451.5, Standard for a Smart Transducer Interface for Sensors and Actuators - Wireless Communication Protocols and Transducer Electronic Data Sheets (TEDS) Formats**

**Submission Title:** [Link Adaptation and Management Protocol (LAMP)]

**Date Submitted:** [Mar-28-2003]

**Source:** [Myung Lee] Organization: [CUNY/Samsung(SAIT)]

Address: [ Department of Electrical Engineering  
The City College, City University New York  
Convent Avenue at 138<sup>th</sup> Street  
New York, NY 10031]

Voice: [212-650-7260], FAX: [212-650-8249], E-Mail:[lee@ccny.cuny.edu]

**Re:** [Call for Proposals; Doc. <related doc #'s>]

**Abstract:** [We propose Link Adaptation and Management Protocol (LAMP), which includes autoconfiguration, session management, data transfer, reliable multicasting/broadcasting]

**Purpose:** [proposal and call for discussion]

**Notice:** This document has been prepared to assist the working group in defining the IEEE P1451.5 draft standard. It is offered as a basis for discussion and is not binding on the contributing individual(s) or organization(s). The material in this document is subject to change in form and content after further study. The contributor(s) reserve(s) the right to add, amend or withdraw material contained herein.

**Release:** The contributor acknowledges and accepts that this contribution becomes the property of IEEE and may be made publicly available by the IEEE P1451.5 Wireless Sensor Working Group.

# < Link Adaptation and Management Protocol (LAMP) for IEEE 1451.5 >

<Myung Lee, Professor>

< Yong Liu, Chunhui Zhu, Xuhui Hu, Taekyoung Kwon >

<CUNY/Samsung>

<tel: 212-650-7260>

<fax: 212-650-8249>

<lee@ccny.cuny.edu>

# Table of Content

1. Introduction
2. Acronyms and abbreviations
3. General Descriptions
  - 3.1 Overview
  - 3.2 Architecture
4. LAM Layer Specifications
  - 4.1 LAM Layer Service Specification
    - 4.1.1 LAM Management Service
    - 4.1.2 LAM Data Service
  - 4.2 LAM Packet Formats

# 1. Introduction

- Goal of our proposal
  - Providing reliable wireless communications between Wireless Transducer Interface Modules (WTIMs) and Network Capable Application Processor (NCAP) for IEEE 1451 networks.
  - Providing the mechanisms of autoconfiguration, session management, data transfer, and reliable multicasting/broadcasting.
- The scope of this proposal
  - Defining the Link Adaptation and Management Layer between the Application Layer and the underlying IEEE wireless MAC Layers, including 802.15.4 and 802.11 families.

## 2. Acronyms and abbreviations

- **IEEE P1451**
  - NCAP: Network Capable Application Processor
  - TEDS: Transducer Electronic Data Sheet
  - WTIM: Wireless Transmission Interface Module
- **IEEE 802.15.4**
  - MLME: MAC subLayer Management Entity
  - MCPS: MAC Common Part Sublayer
  - PLME: Physical Layer Management Entity
  - SAP: Service Access Point
  - PD: PHY layer Data service
  - PIB: PAN Information Base
  - GTS: Guaranteed Time Slot
  - CFP: Contention Free Period
- **LAM**
  - LAM: Link Adaptation and Management
  - LAMP: Link Adaptation and Management Protocol
  - LD: LAM Layer Data Service
  - LLME: LAM Layer Management Entity
  - PPQ: Pending Packet Queue
  - MIB: Management Information Base
  - DCA: Dynamic Channel Adaptation
  - BP: Broadcast Period
- **APPL**
  - APPL: Application
  - ALME: Application Layer Management Entity

# 3. General Descriptions

## 3.1 Overview

3.1.1 What we are addressing?

3.1.2 Why IEEE 802.15.4 for IEEE P1451.5?

3.1.3 IEEE 802.15.4 Overview

3.1.4 IEEE 802.11b vs. IEEE 802.15.4

## 3.2 Architecture

# 3.1.1 What we are addressing?

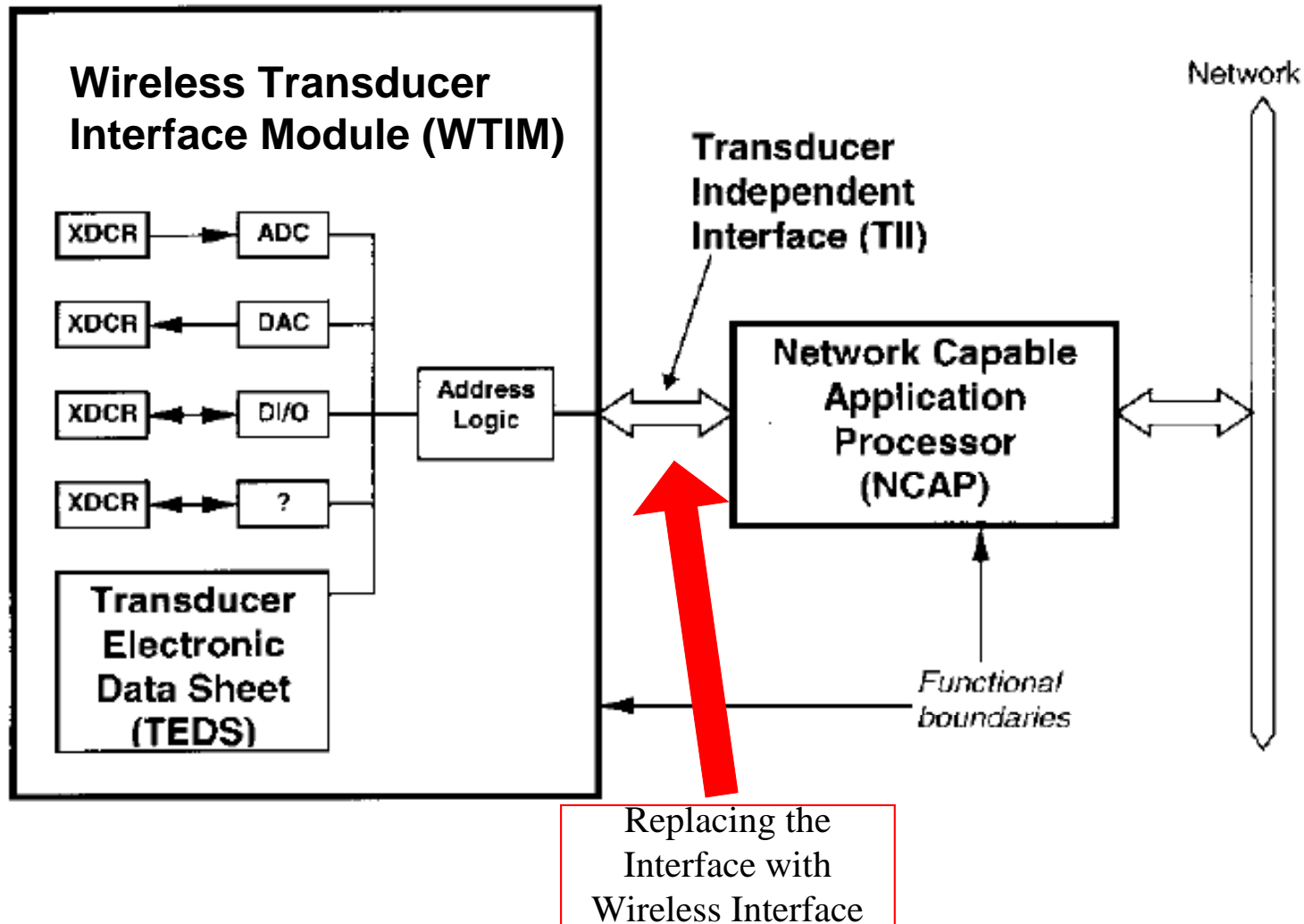

# What we are defining?

## P1451.5 Standardization Options

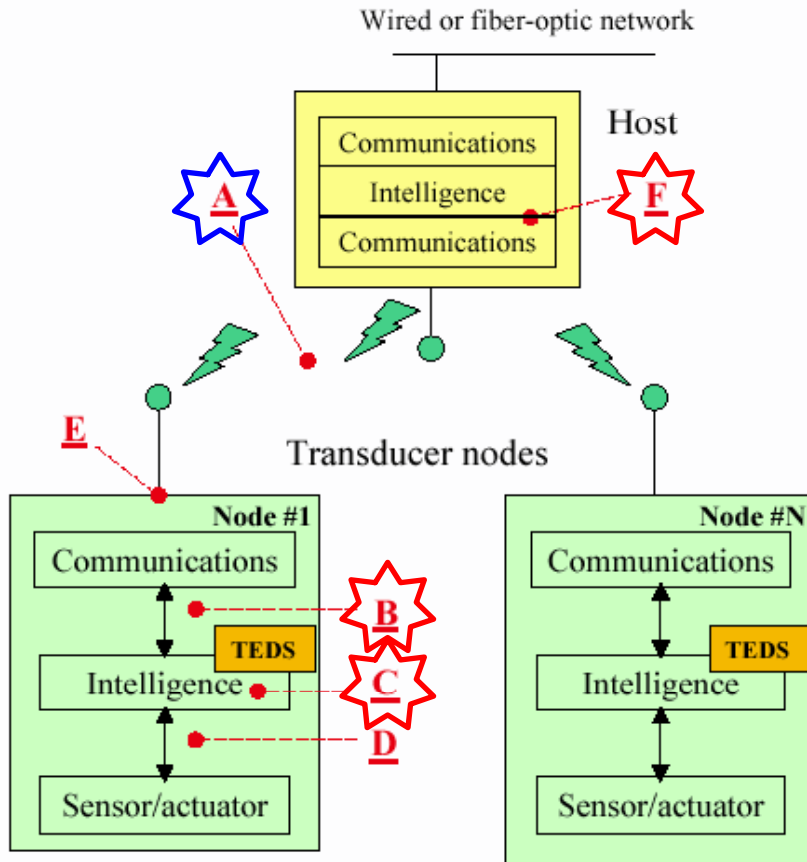

**Standardization options** (modified based on discussion at P1451.5 meeting on 5/7/02 )

**A- HW** - RF spectrum, wireless protocol (Adopt an industry standard, data format), could do Appendix X, each with profile to address

★ **A- SW** - Wireless message formats, data/control model, security model (Part of an industry standard)

**B- HW** - Interface between intelligence and wireless transceiver (Do not standardize)

★ **B- SW** - Message formats (Define or adopt from P1451.3)

★ **C- SW** - TEDS (Contents and size - define or adopt from P1451.3), data/control models (Define or adopt from P1451.3)

**D- HW** - Low level wired interface (Do not standardize)

**E- HW** - Packaging, antennas (Do not standardize)

**F- HW** - Interface between host intelligence and wireless transceiver (Do not standardize)

★ **F- SW** - API between host intelligence and wireless transceiver (Define or adopt from P1451.3)

**In general, the objectives are:**

- Interoperable in spectrum level.
- Don't want to lock on a specific vendor HW, but has profiles for Bluetooth, 802.11b, 802.15.4, and others protocols, etc.
- Define message passing format, specify host API, Java, DCOM, and COM++, etc. , and have a few reference implementations.
- Transducer nodes = STIM
- Host = NCAP.



Standard we adopted (HW + SW)



Standard we proposed (SW only)

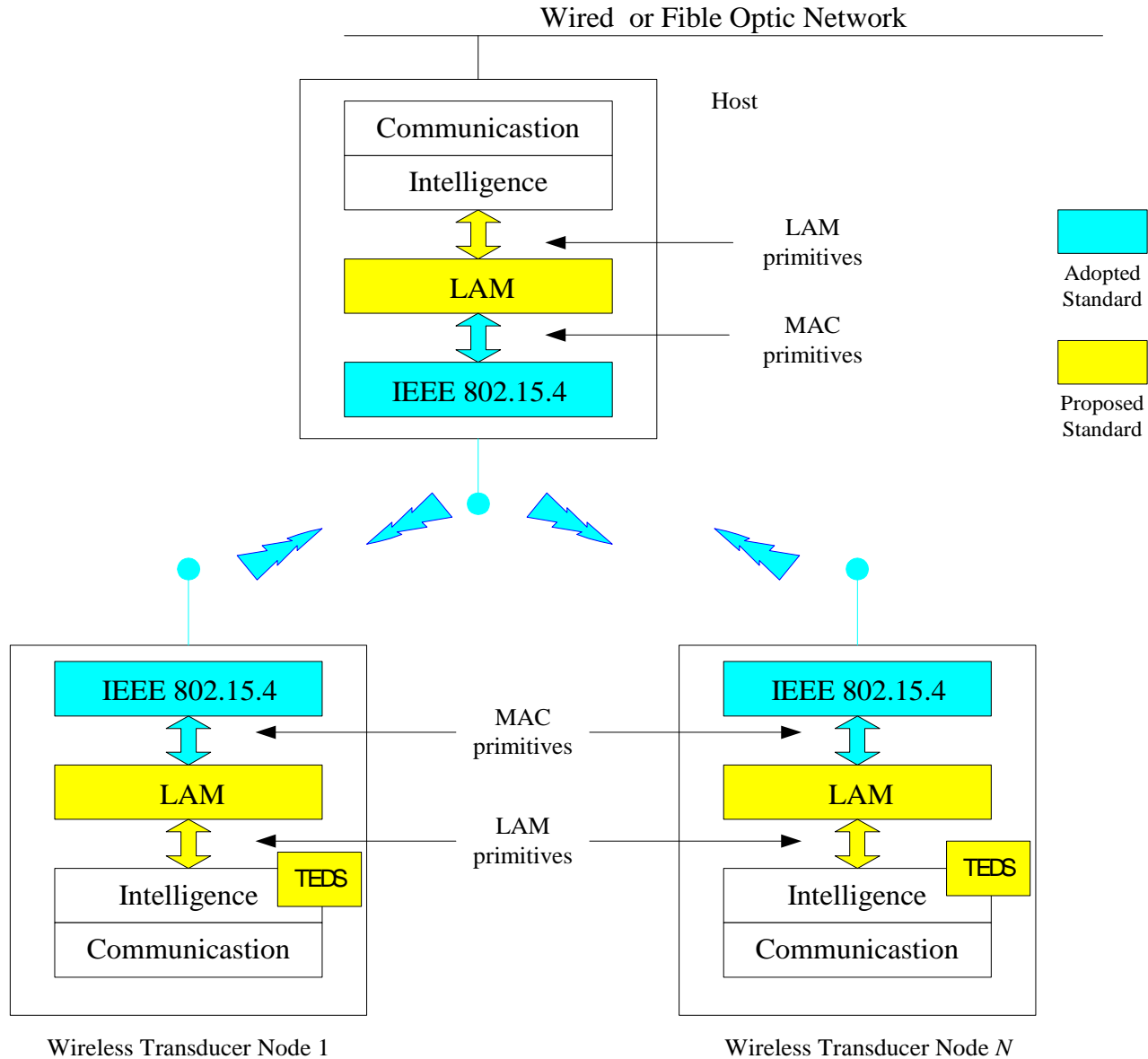

# Our View

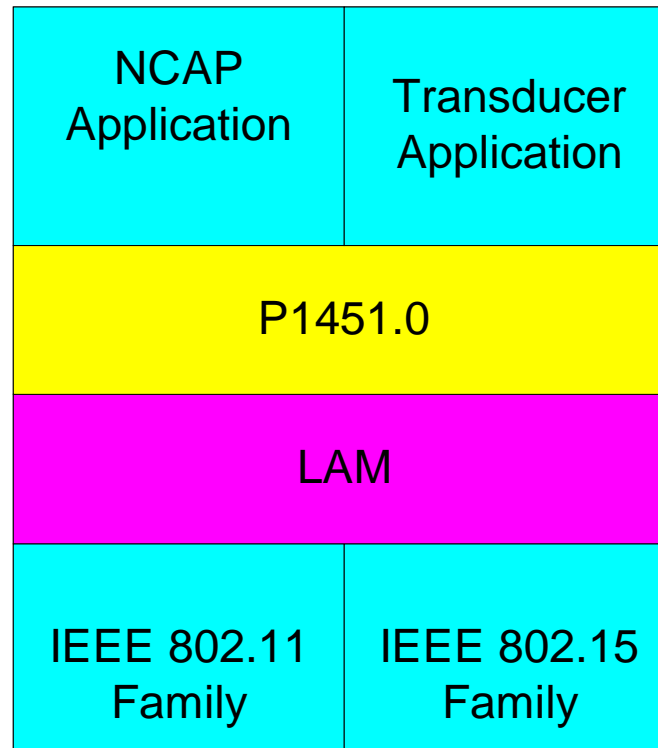

LAM - Link Adaptation and Management

# LAM vs. ZigBee

- ZigBee:
  - The ZigBee Alliance is an association of companies working together to create a low-cost, low power consumption, two-way, wireless communications standard based on IEEE 802.15.4 standard.
  - ZigBee standard defines a protocol suite/profile from network layer to application layer.
  - ZigBee is an ongoing project, the first draft is expected to be available in June, 2003
  
- What LAM has and ZigBee does not in current version:
  - Reliable end-to-end transmission
  - Reliable broadcast/multicast support
  - Sleeping mode support
  - Differentiated service
  - Data aggregation support

## 3.1.2 Why IEEE 802.15.4 for IEEE P1451.5

- 802.15.4 satisfies major 1451.5 requirements

Criteria	Yes/No	Detail
Reliability		Acknowledgement
Message resolution		Up to 113 bytes
Sensors per access point		256 and up
Latency		Beacon, GTS
Security		Access control list

- Also, 802.15.4 is designed to support **long battery life**, **low cost**, and **easy installation**.

## 3.1.3 IEEE 802.15.4 Overview

- USER level
  - Wireless personal area network
  - Low power, low cost, long battery life
  - Easy installation
- MAC level
  - Star and peer-to-peer topology
  - Contention period and contention-free period
  - Reliability: fully acknowledged protocol
  - Flexible addressing modes
- PHY level
  - 16 channels in the 2.4GHz band / 10 channels in the 900 MHz band / 1 channels in the 800 MHz band
  - Maximum 250 Kbps bandwidth for each channel
  - Range: 10m indoor, 30m outdoor

## 3.1.4 IEEE 802.11b vs. IEEE 802.15.4

	IEEE 802.15.4	IEEE 802.11b
Communication Range	Short (10m indoor, 30m outdoor)	Long (100m indoor, 300m outdoor)
Power Consumption	Low	High
Cost	Low	High
Battery Life	Long	Short
Bandwidth	Small	Large
Freq. Band	2.4GHz/900MHz/800MHz	2.4GHz

Although this proposal is based on IEEE 802.15.4, it can be easily ported to IEEE 802.11b because the services provided by these two standards are essentially the same.

## 3.2 Architecture

# IEEE P1451.5 Protocol Reference Model

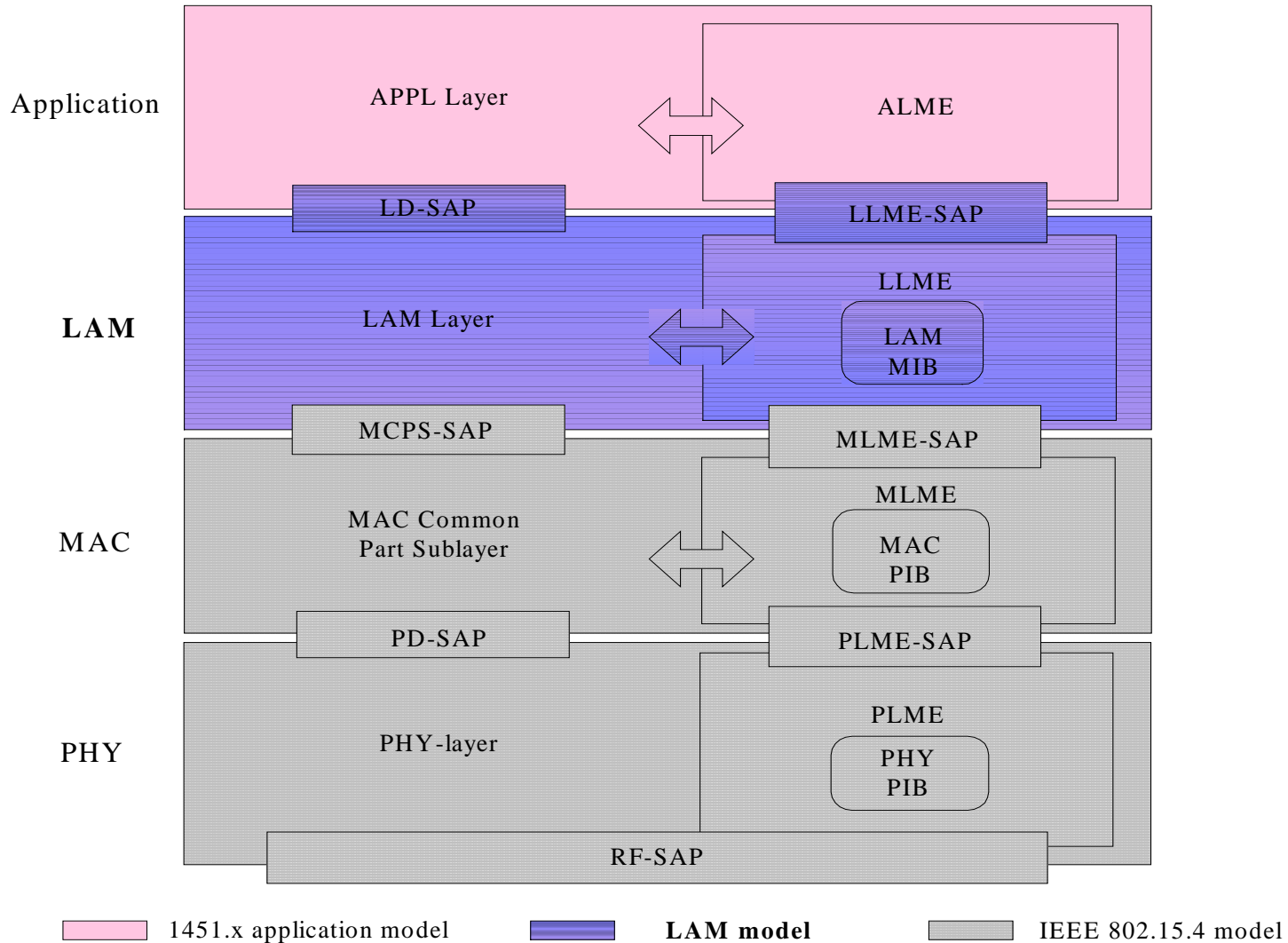

# Layer Service Specifications

- **APPL Layer:** provides smart transducer functions defined in IEEE P1451.2 and IEEE P1451.3.
- **LAM Layer:** provides an interface between the APPL layer and the IEEE 802.15.4 MAC layer.
  - The LLME provides the LAM management service, which can be accessed through the LLME-SAP by the ALME.
  - The LAM data service can be accessed through the LD-SAP by the APPL layer.
- **MAC and PHY Layers:** are defined in IEEE 802.15.4 to provide the wireless communication ability and the medium access control.

# 4. LAM Specifications

## 4.1 LAM Service Specification

4.1.1 LAM Management Service

4.1.2 LAM Data Service

## 4.2 LAM Packet Formats

4.2.1 General Packet Formats

4.2.2 Data Packet Formats

4.2.3 Acknowledgment Packet Formats

4.2.4 Control Packet Formats

# 4.1.1 LAM Management Service

## 4.1.1.1 Session Management

### 4.1.1.1.1 Overview of the LAM Management Services

### 4.1.1.1.2 Details of the LAM Management Services

- NCAP Startup
- WTIM Startup and Addressing
- Service Discovery
- WTIM Disassociation/Detach
- WTIM Orphan
- Unexpected WTIM Detach
- Service Primitives
- Dynamic Channel Adaptation

## 4.1.1.1.1 Overview of the LAM Management Service

The LLME provides a complete set of management services to support “plug and play”. These services include:

- Device Startup
- WTIM Addressing
- Service Discovery
- WTIM detaching
- Connection and channel maintenances

# 4.1.1.1.2 Details of the LAM Management Services

# Message Sequence Chart of NCAP Startup

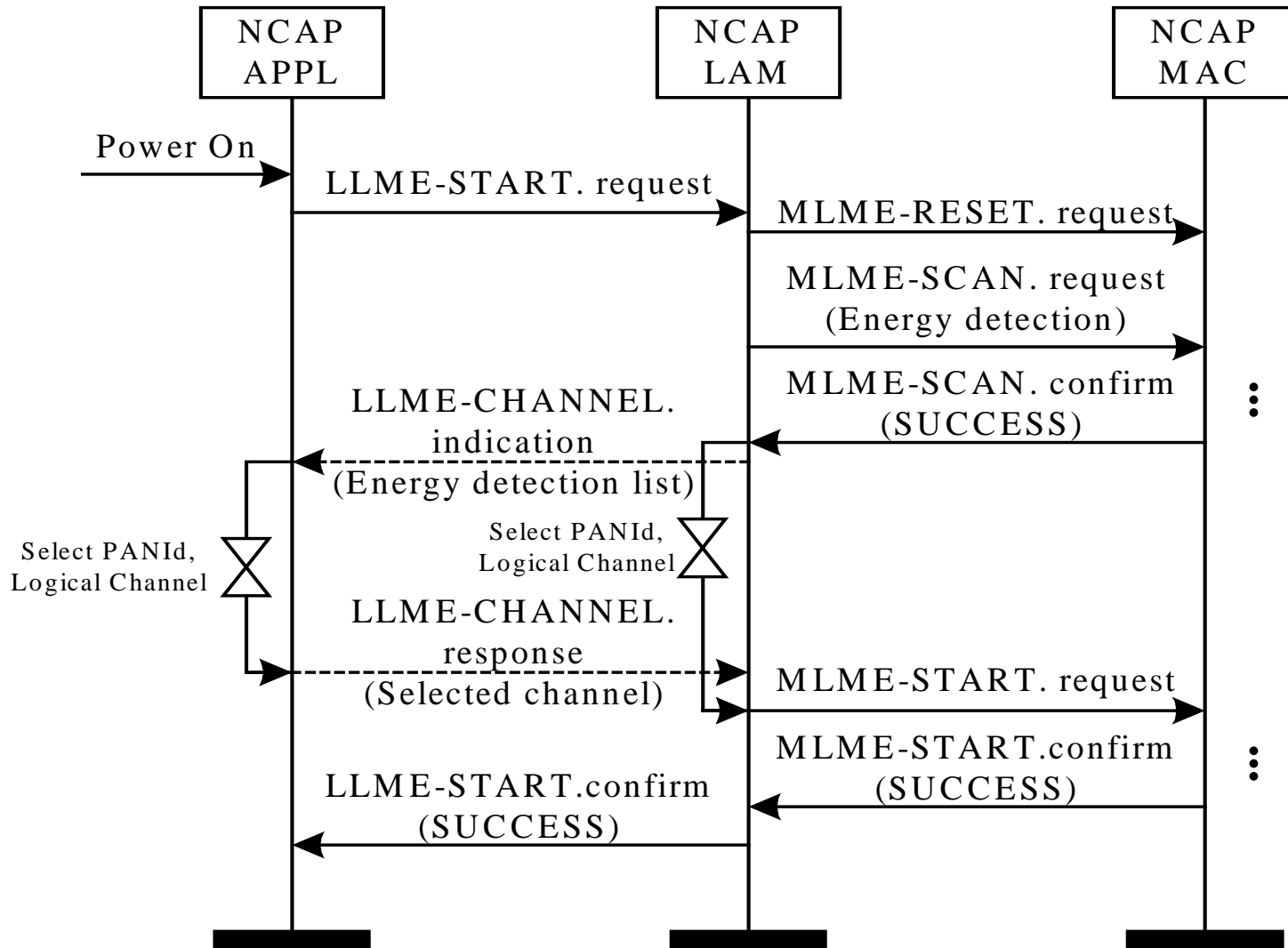

# NCAP Startup Procedure

- When the NCAP is powered on, it generates an *LLME-START.request* primitive to initiate the LAM layer and clarify some of its services. For example, a parameter in the *LLME-START.request* decides whether the channel selection should be determined at the LAM layer or at the application layer.
- Upon receiving the *LLME-START.request*, the LLME directs the MLME to reset as well as scan the channels and collect the channel conditions (energy measurement list, etc.). If the application layer wants to choose a proper channel, the *LLME-CHANNEL.indication* is used to relay the channel conditions to the ALME and the corresponding *LLME-CHANNEL.response* will return the channel choice.
- The LLME then asks the MLME to begin transmitting beacons by sending *MLME-START.request*.
- Finally, with the *MLME-START.confirm* from the MLME, the LLME sends the ALME an *LLME-START.confirm* to report the NCAP startup status.

# Message Sequence Chart of WTIM Startup

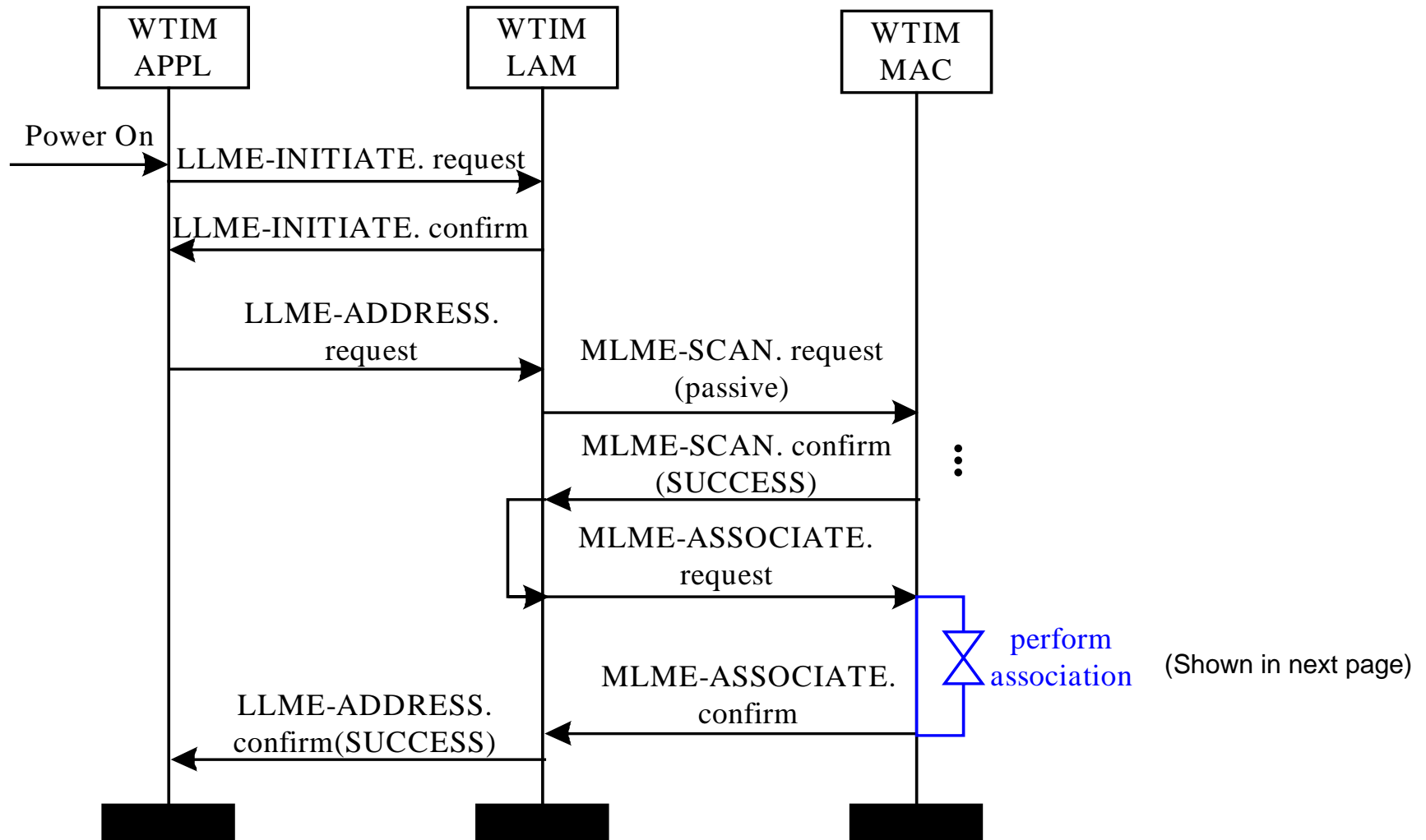

# Message Sequence Chart of WTIM Addressing

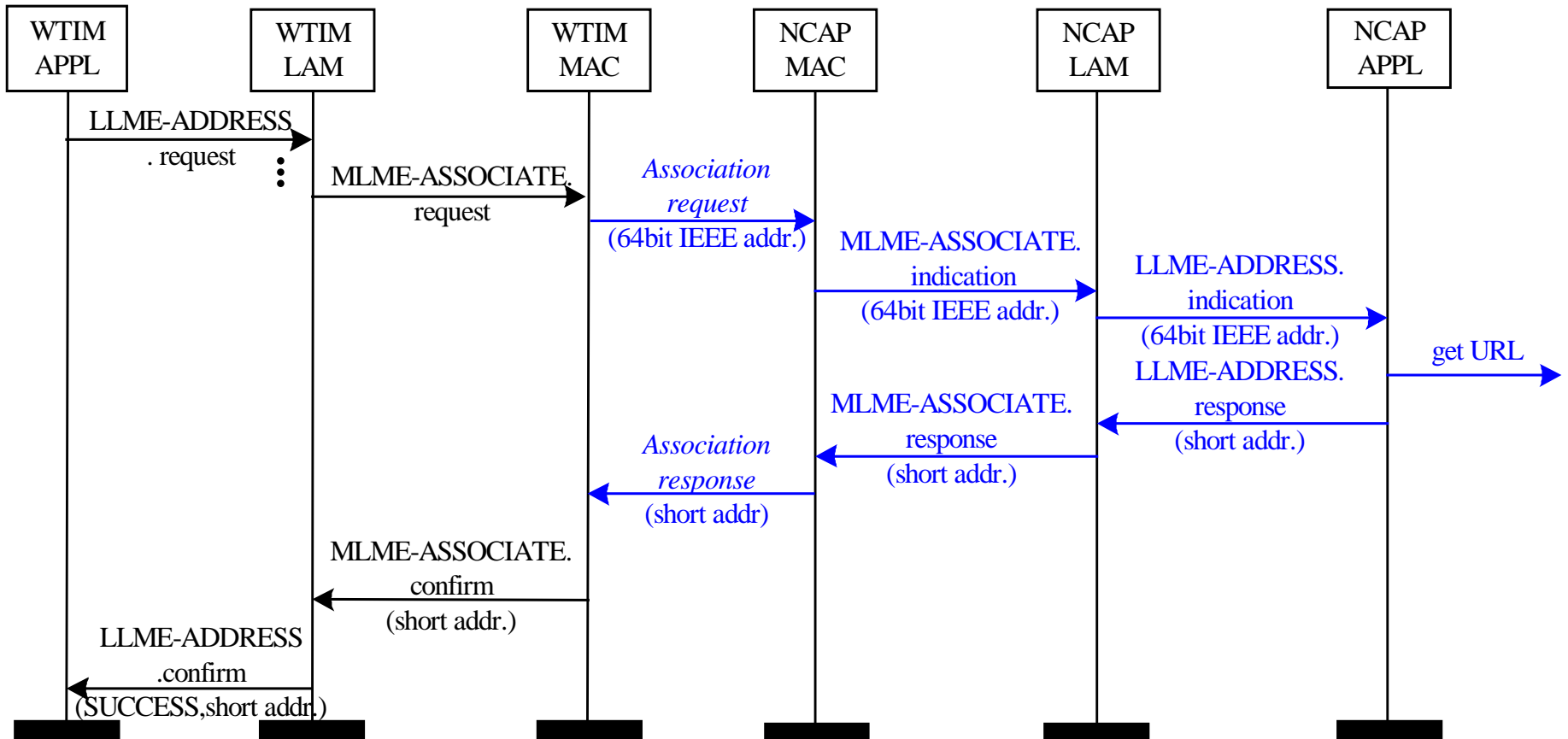

# WTIM Startup and Addressing

- When the WTIM is powered on or reset, it generates an *LLME-INITIATE.request* and an *LLME-INITIATE.confirm* for initial setup (such as the default values of the MIB variables) in the LAM.
- After the initiation, the WTIM generates an *LLME-ADDRESS.request* to discover the NCAP and establish “association” with the NCAP. If the NCAP has sufficient resources (such as address spaces) to support the WTIM, it shall assign and return a short address to the WTIM.
- The NCAP APPL layer may send the extended 64-bit IEEE address of the WTIM to an address resolution server to request a URL for the WTIM.

# Message Sequence Chart of Service Discovery

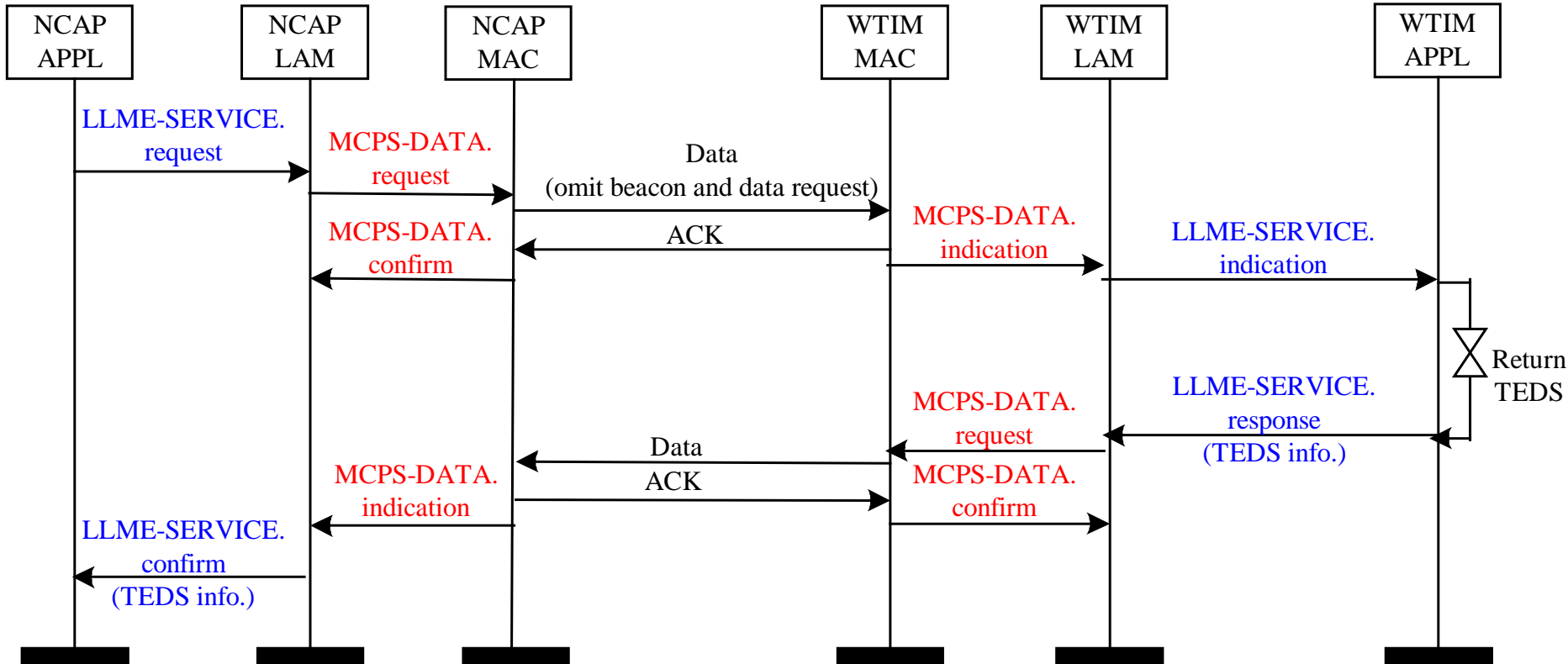

# Service Discovery

- After the WTIM establishes “association” with the NCAP, the NCAP needs to collect the TEDS information from the WTIM. To do this, the NCAP generates an *LLME-SERVICE.request* primitive with the requirement of the desired TEDS information.
- The *LLME-SERVICE.request* is then encapsulated as a MCPS data in the LAM and sent out using *MCPS-DATA.request*.
- After the WTIM receives and decapsulates the data, it sends an *LLME-SERVICE.indication* to the APPL layer for corresponding TEDS information.
- To return the required TEDS information, the WTIM APPL layer generates a *LLME-SERVICE.response*, which is also encapsulated and sent out in the MAC layer as a data.
- Finally, the NCAP obtains required TEDS information from *LLME-SERVICE.confirm*.

# Message Sequence Chart of WTIM Disassociation — NCAP Initiated

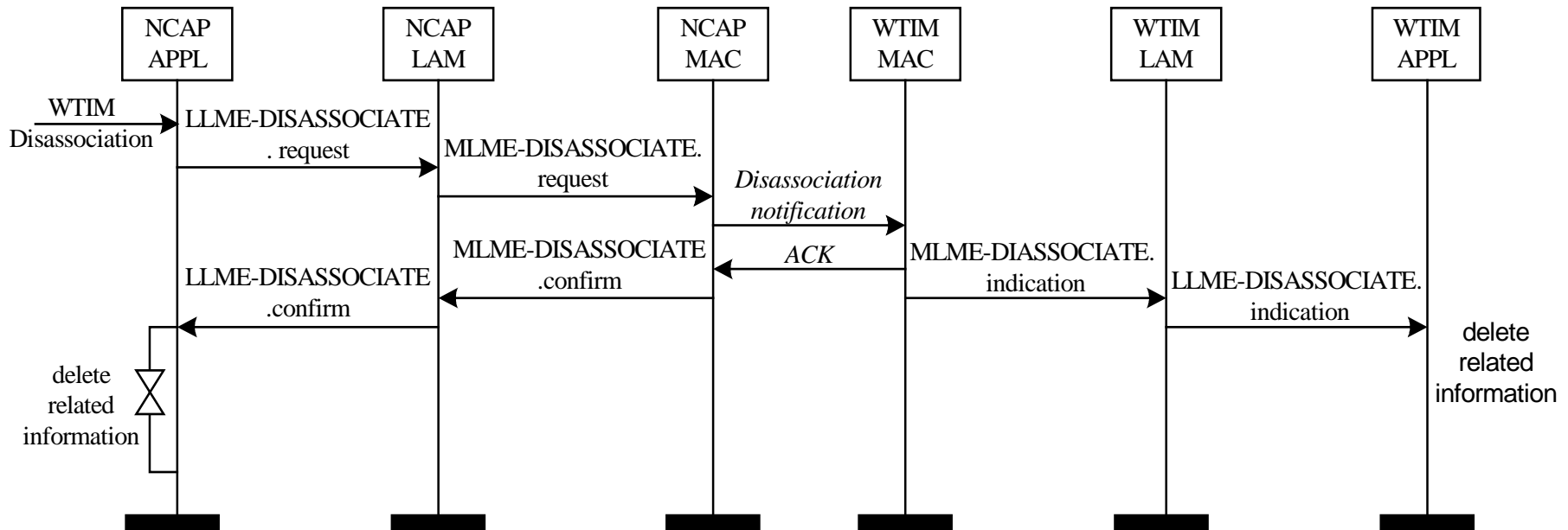

# Message Sequence Chart of WTIM Detach — WTIM Initiated

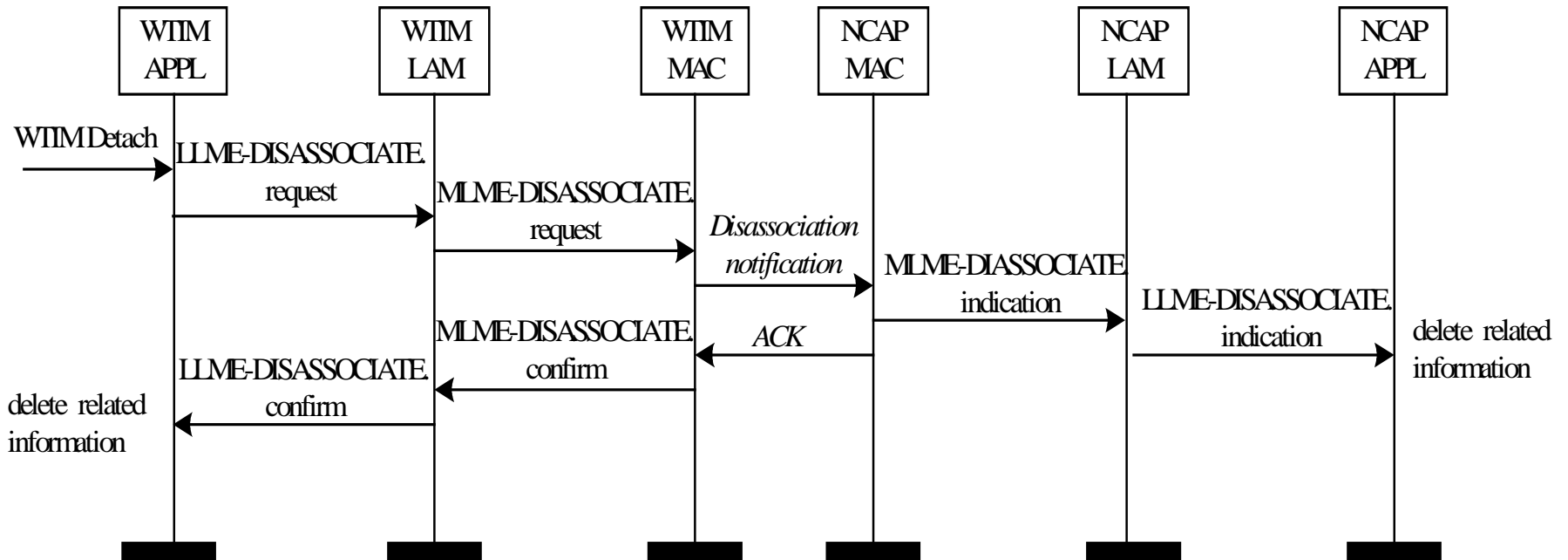

# WTIM Detach/Disassociation Procedure

- When the NCAP wants to disassociate a WTIM, it generates *LLME-DISASSOCIATE.request* to notify the LAM layer. This primitive invokes the LLME to direct the MLME to generate *MLME-DISASSOCIATE.request*.
- After receiving the *MLME-DISASSOCIATE.indication*, the WTIM shall generate *LLME-DISASSOCIATE.indication* to the APPL layer so that the APPL layer can delete all information allocated by the NCAP (PAN id, short address, etc.).The NCAP will also delete the information related to the WTIM (the short address, TEDS description, etc.) at its APPL layer after it receives *LLME-DISASSOCIATE.confirm*.
- When a WTIM wants to detach from the NCAP, it generates *LLME-DETACH.request* to notify the LAM layer. This primitive invokes the LLME to direct the MLME to generate *MLME-DISASSOCIATE.request*.
- After receiving the *MLME-DISASSOCIATE.indication*, the NCAP shall generate *LLME-DISASSOCIATE.indication* to the APPL layer to delete the information related to the WTIM. The WTIM will also delete the information allocated by the NCAP at its APPL layer after it receives *LLME-DISASSOCIATE.confirm*.

# Message Sequence Chart of Orphan WTIM

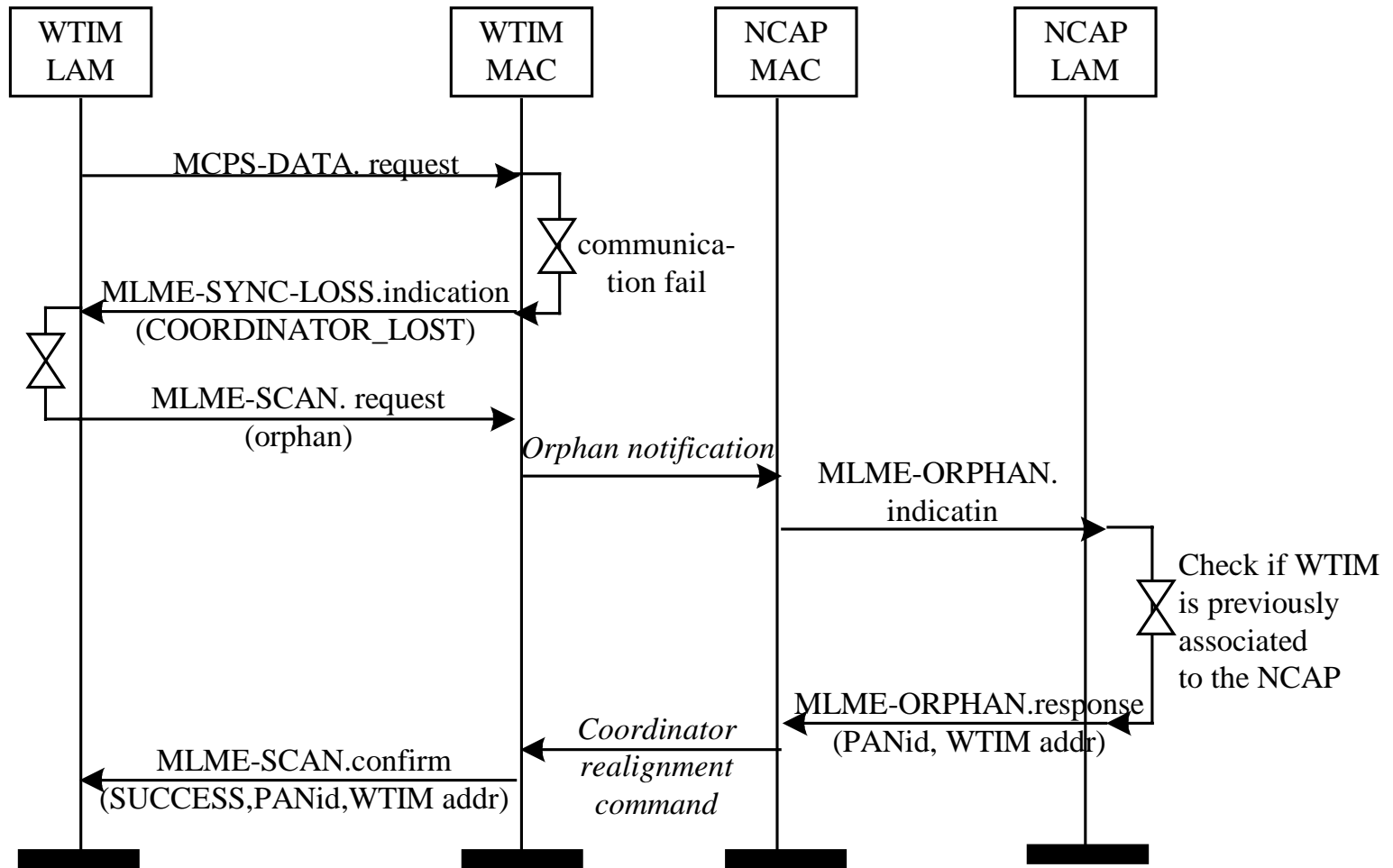

# WTIM Orphan Procedure

- IF a WTIM fails to communicate with the NCAP for *aMaxCommunicationsFailures* successive times\*, it declares itself orphaned by generating *MLME-SYNC-LOSS.indication* with a loss reason of *COORDINATOR\_LOST*. When the LLME receives the primitive, it directs the MLME to scan the channels by issuing *MLME-SCAN.request* with a scan type of orphan scan.
- After the NCAP gets *MLME-SCAN.indication* in the LLME, and if it finds a record of the WTIM, it shall generate a *MLME-ORPHAN.response*. Otherwise, it ignores the command.
- The orphan scan shall terminate when the WTIM receives a coordinator realignment command from the NCAP or the specified set of logical channels has been scanned.

\* A single communication failure occurs when a transaction fails to reach its intended destination, i.e. an ACK is not received after *aMaxFrameRetries* attempts.

# Message Sequence Chart of Unexpected WTIM Detach

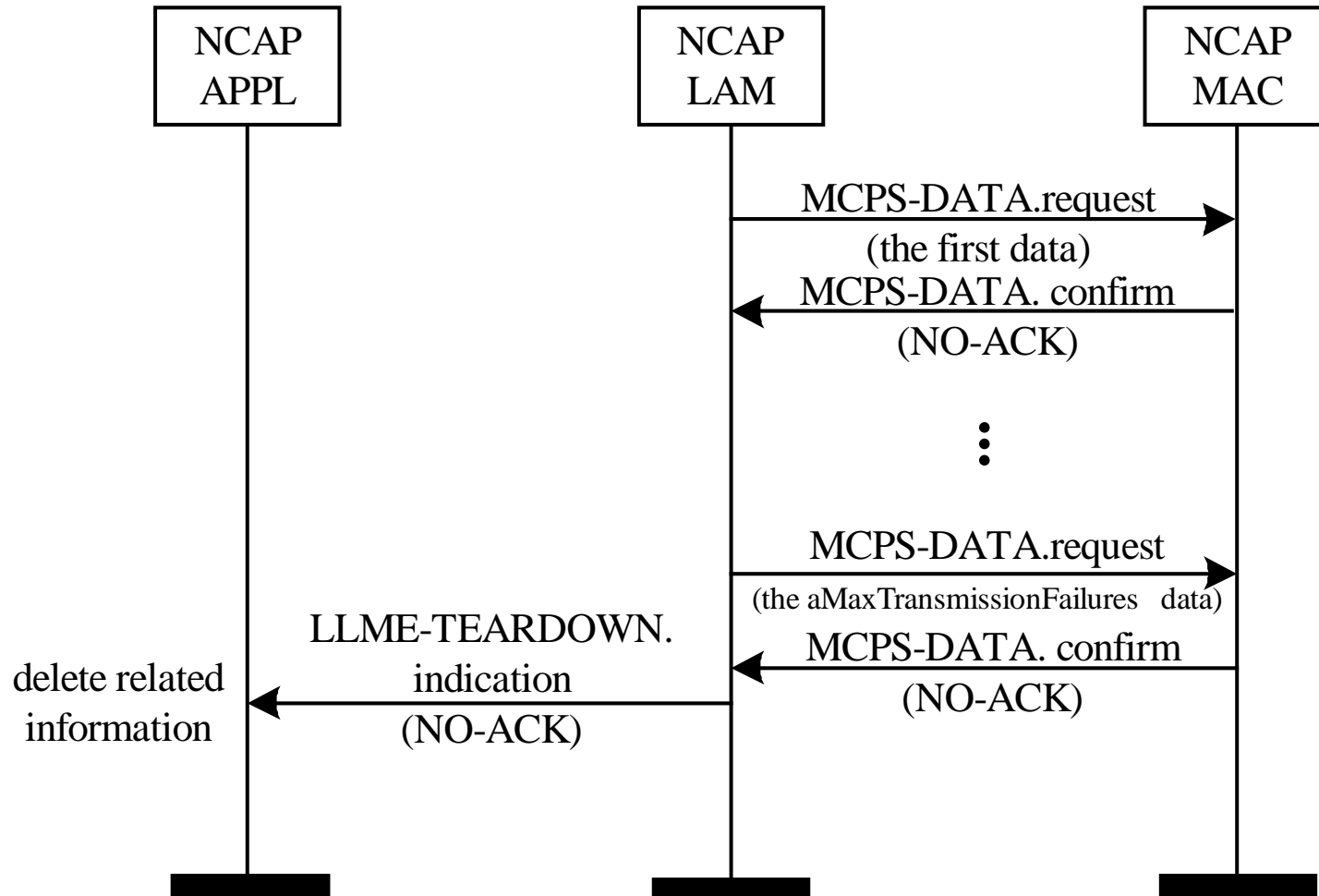

# Unexpected WTIM Detach Procedure

- Due to some unexpected reasons of a WTIM, such as power down or departure without disassociation, the NCAP may lose the contact with the WTIM. In this case, the NCAP should consider to disassociate the WTIM with the decision of its APPL layer.
- If NCAP has failed to communicate with a WTIM for *aMaxTransmissionFailures* successive times, it shall conclude that the WTIM has detached unexpectedly and shall generate an *LLME-TEARDOWN.indication* primitive to the ALME with a tear down reason of *NO-ACK*.
- Upon receiving this primitive, the ALME of the NCAP will execute disassociation procedure if it wants.

# Dynamic Channel Adaptation (DCA)

- NCAP provides the DCA service to applications.
- NCAP also provides the report (link quality) service to applications.
- NCAP reports the status of link quality regularly or when the link quality is poor or upon application's request.
- In this proposal, the NCAP maintains *AvgLinkQuality* for each WTIM.
- *AvgLinkQuality* is the average of the recently received  $N$  MAC frames.
- Whenever the LAM reports link quality, it resets the *AvgLinkQuality*.

# DCA at NCAP (cont'd)

- *LLME-DCA.request*: to initiate DCA
- *LLME-DCA.indication*: to inform channel change
- *LLME-DCA.confirm*: to report the DCA result
- Main procedure
  - NCAP: *MLME-SCAN* primitive
  - NCAP → WTIM: *LLME-DCA* message (broadcast)
  - WTIM: *MLME-SET* primitive
  - WTIM: *MLME-SYNC* primitive
  - NCAP: *MLME-START* primitive
- NCAP waits *aMaxProcessTime* between sending *LLME-DCA* message and invoking *MLME-START.request*.

# DCA Sequence Chart

NCAP

WTIM

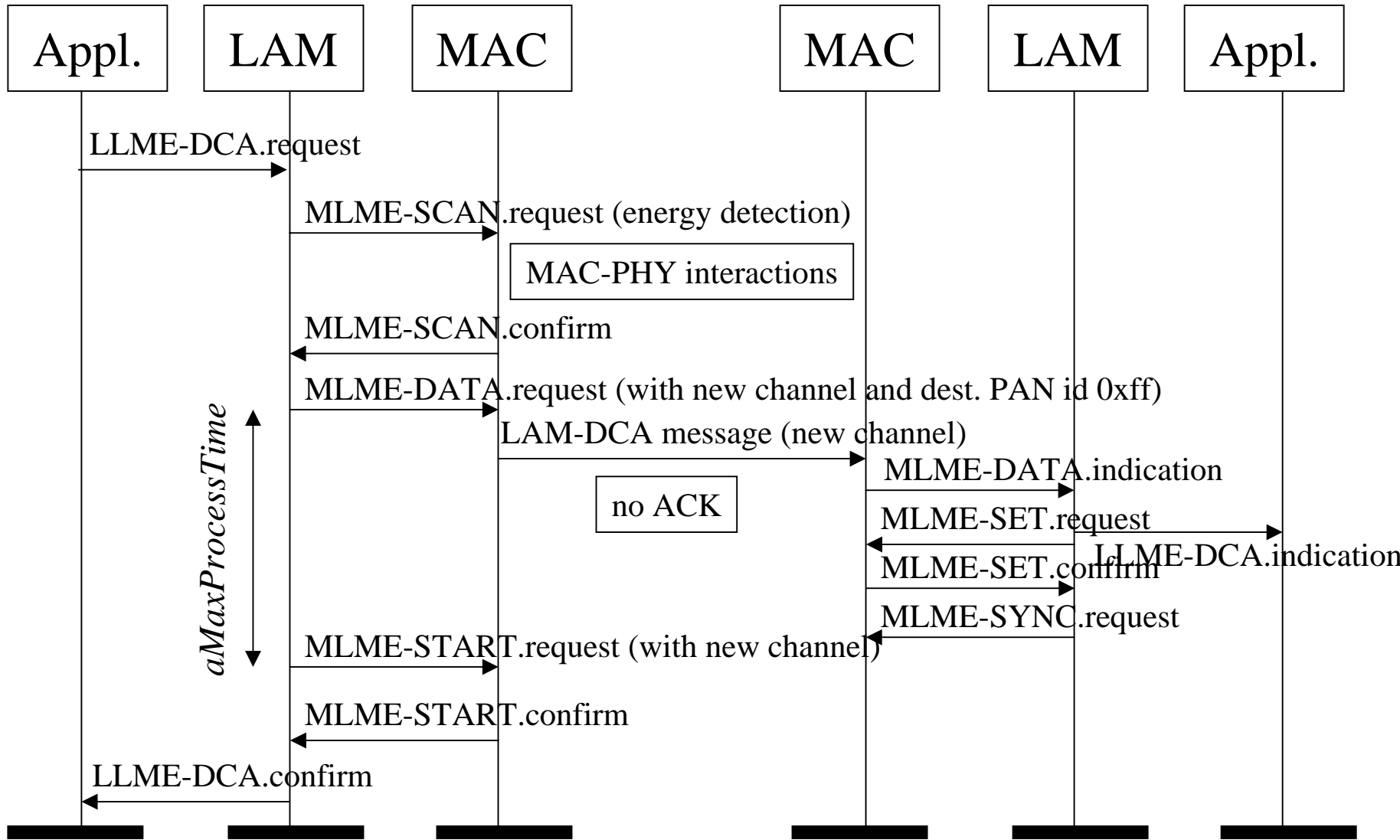

# Report service in LAM layer

- *LLME-REPORT.request*
  - Default setting is for all WTIMs
  - The optional setting may specify WTIMs of interest
- *LLME-REPORT.confirm*
  - Report  $N$ , *AvgLinkQuality* for each WTIM

# Primitives accessed through LLME-SAP

Name	Request	Indication	Response	Confirm
LLME-START	X			X
LLME-CHANNEL		X	X	
LLME-INITIATE	X			X
LLME-ADDRESS	X	X	X	X
LLME-SERVICE	X	X	X	X
LLME-DISASSOCIATE	X	X		X
LLME-TEARDOWN		X		
LLME-GET	X			X
LLME-SET	X			X
LLME-DCA	X	X		X
LLME-REPORT	X			X

## 4.1.2 LAM Data Service

4.1.2.1 Functions to Support

4.1.2.2 Data Service Primitives

4.1.2.3 Data Scheduling

4.1.2.4 Batch Delivery

4.1.2.5 Reliable Broadcasting/Multicasting

# 4.1.2.1 Functions to Support

# Application Functions Supported

- From P1451.2 standard
  - Addressing - functional and channel
  - Data Transport - data read from and written to the WTIM
  - Triggering - global or channel
  - Interrupts - masks, status registers
  - Control - WTIM or channel
  - Optional functionality - e.g. self calibration
- From P1451.3
  - Support of multiple WTIMs

# Data Transmission Mechanisms Defined in IEEE 802.15.4

- Packet based data transmission mode
- Star topology network with centralized control at the coordinator
- Beacon based channel synchronization mechanism
- A well-defined superframe structure supporting both contention-based and contention-free medium access
- An “indirect” data transfer scheme to handle data delivery from a coordinator to a device

# Simplification of the Triggering Processes

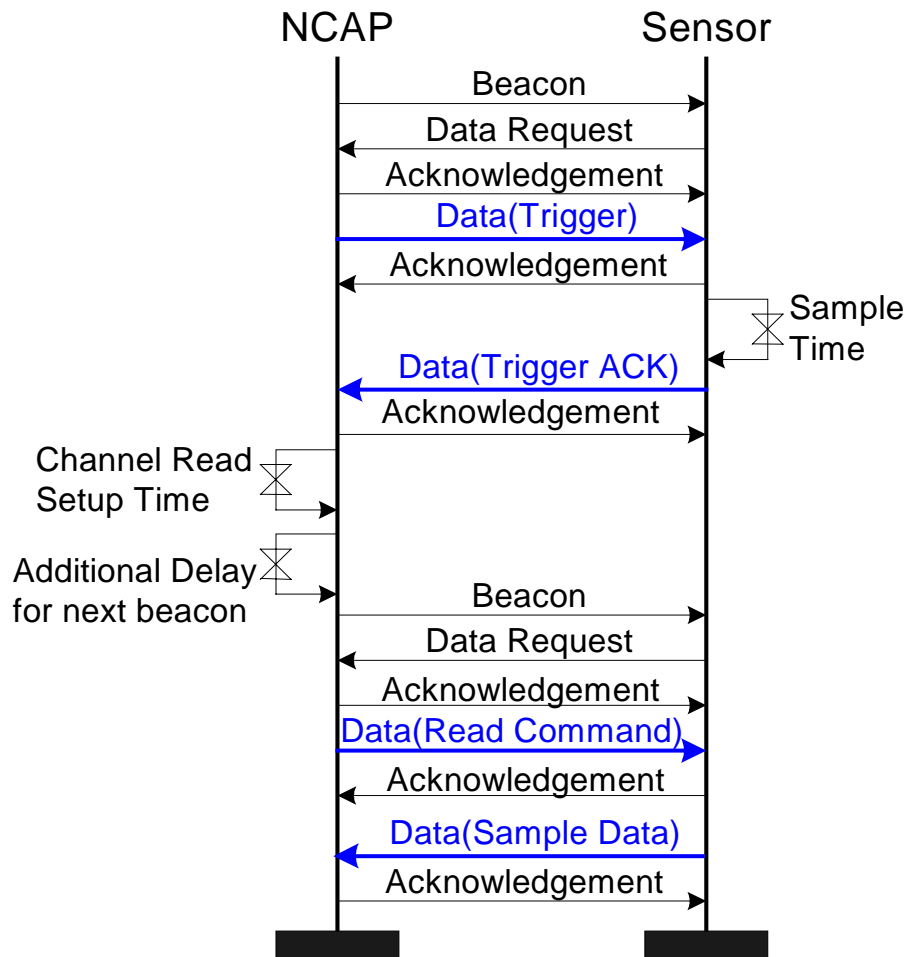

- Some application processes can be simplified to be consistent with the packet level transmission mode.

- An example is the triggering processes.

- The separation of the *trigger* command and the *read* command introduces redundant traffic and additional delay.

# Simplification of the Triggering Processes (Cont.)

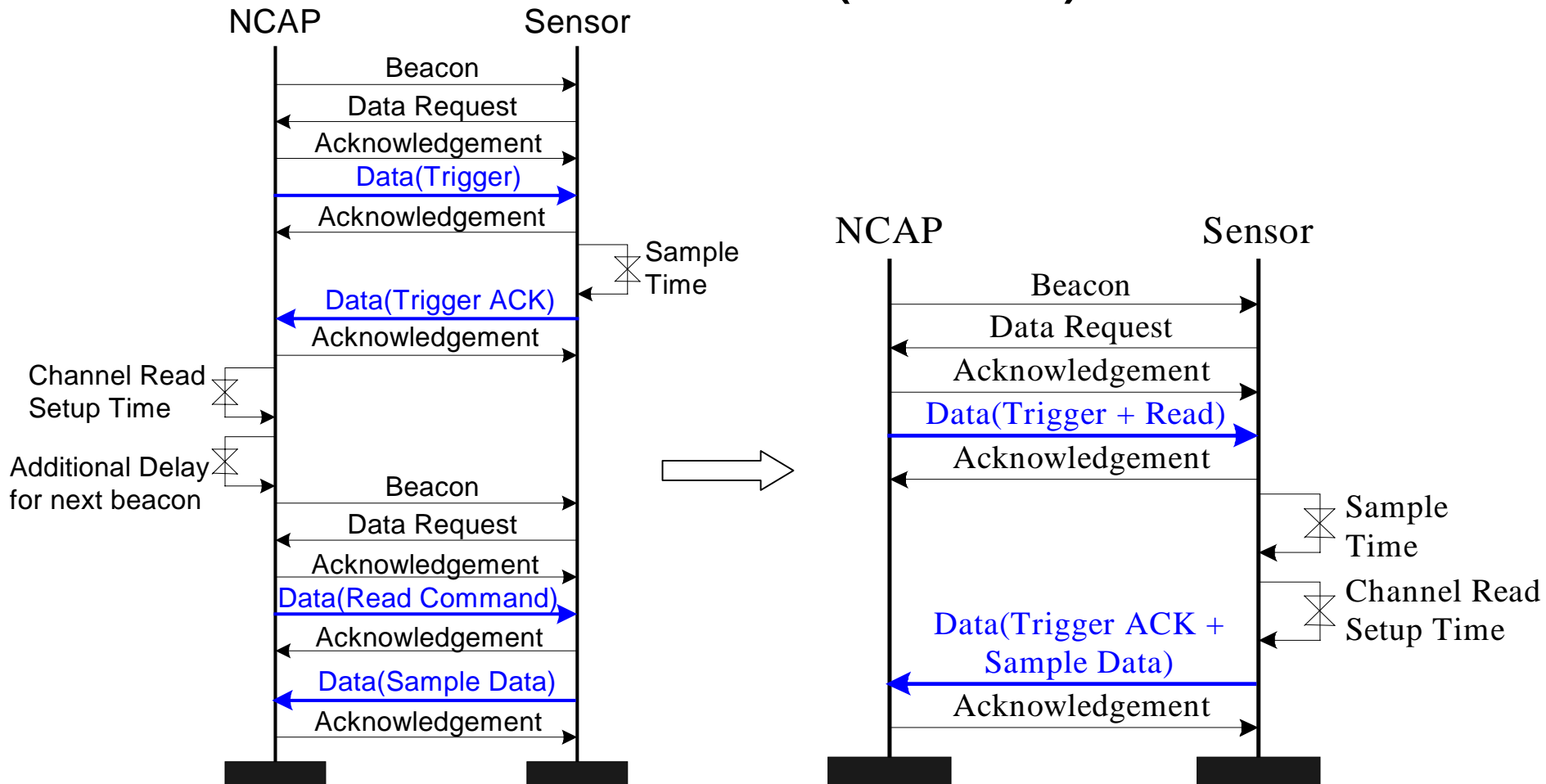

# Simplification of the Triggering Processes (Cont.)

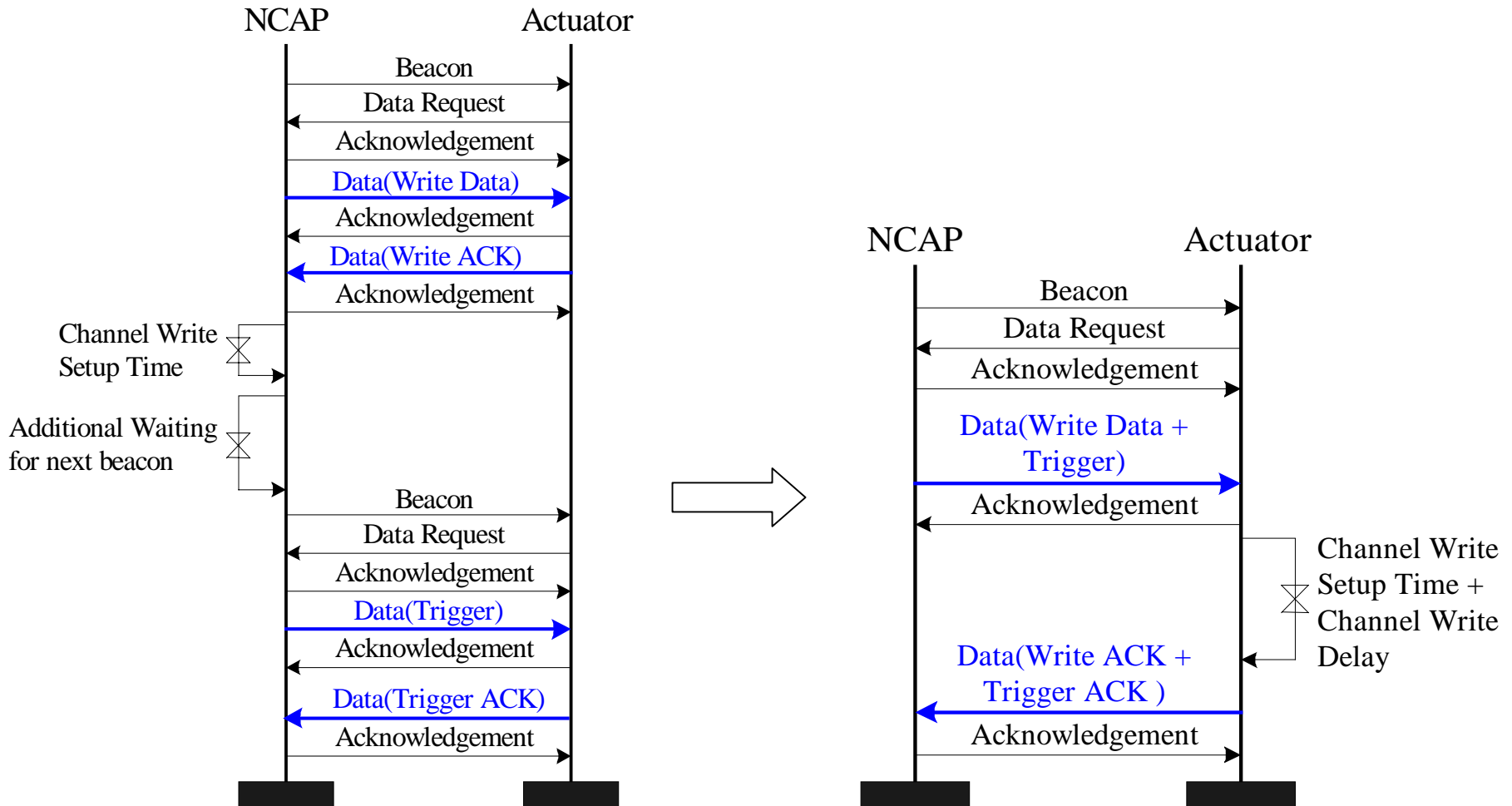

# Supporting Transducer Functions Using LAM Data Service

- The LAM layer SAP (LD-SAP) supports the transport of application protocol data units (APDUs) between peer APPL entities.
- To support application level reliability, we define four primitives (*LD-DATA.request*, *LD-DATA.indication*, *LD-DATA.response*, *LD-DATA.confirm*) in the LD-SAP.
- The LAM layer creates LAM protocol data units (LPDUs) according to the requirements of the application layer and passes them to the MAC common part sublayer via the MCPS-SAP defined in IEEE 802.15.4.

# 4.1.2.2 Data Service Primitives

# Message Sequence Chart Describing the MAC Data Service

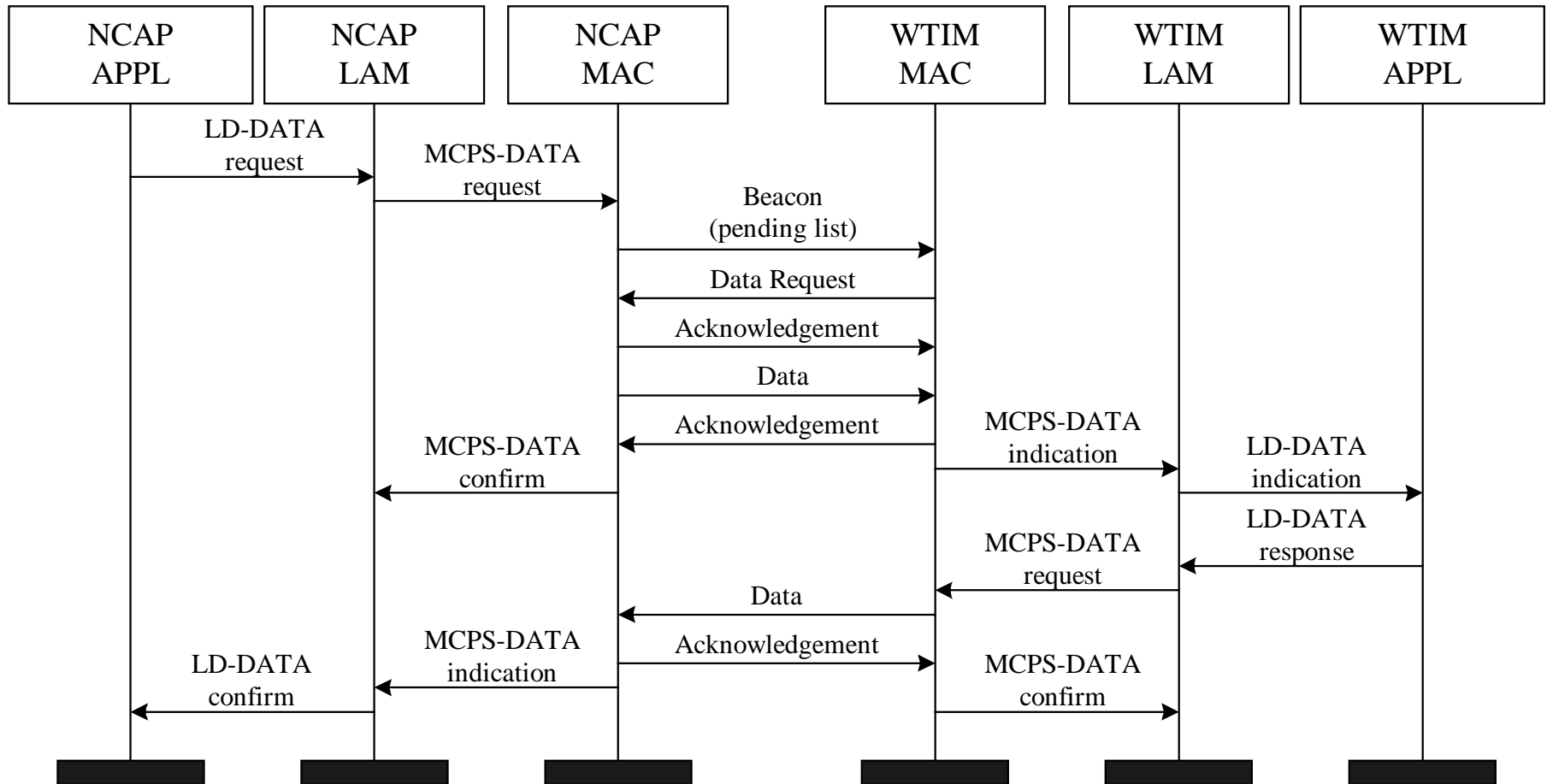

Message Sequence For NCAP-Initiating Traffic

# Message Sequence Chart Describing the MAC Data Service (Cont.)

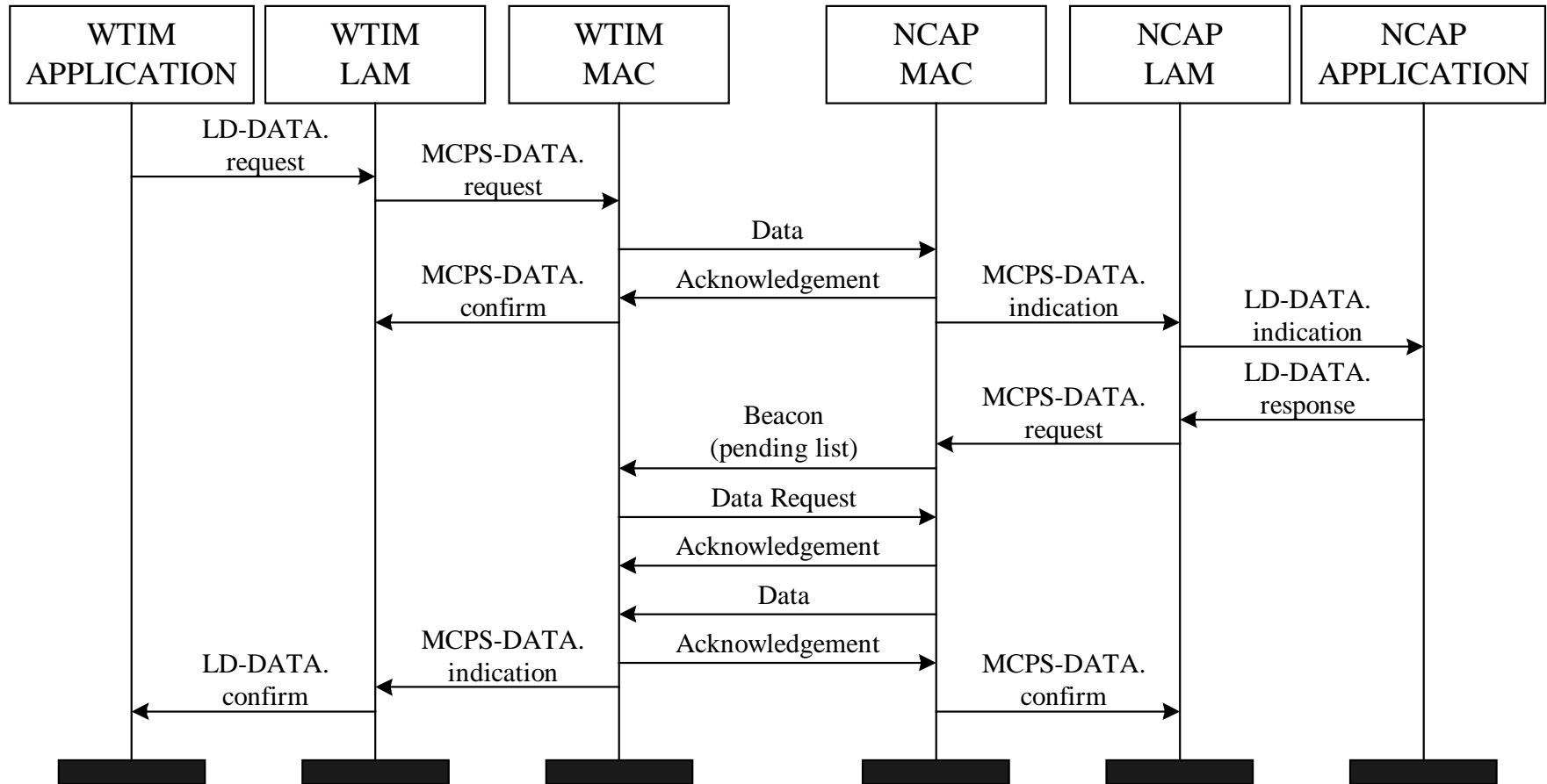

Message Sequence For WTIM-Initiating Traffic

# LAM Data Transfer Primitives

The *LD-DATA.request* and the *LD-Data.response* include the same set of parameters:

```
{  
  AddrMode,  
  SrcAddr,  
  DstAddr,  
  SeqNum,  
  lsdu,  
  lsduLength,  
  BroadcastAttr,  
  PriorityLevel,  
  TxOptions  
}
```

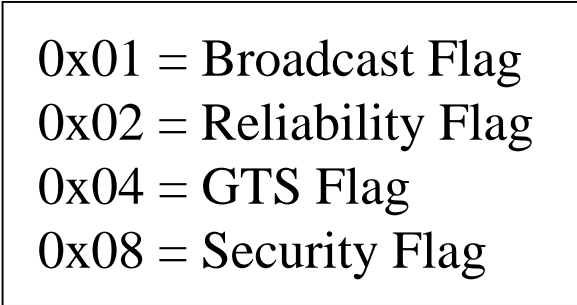

0x01 = Broadcast Flag  
0x02 = Reliability Flag  
0x04 = GTS Flag  
0x08 = Security Flag

# LAM Data Transfer Primitives (Cont.)

The *LD-DATA.indication* and the *LD-Data.confirm* include the same set of parameters:

```
{  
  AddrMode,  
  SrcAddr,  
  DstAddr,  
  SeqNum,  
  lsdu,  
  lsduLength,  
  BroadcastAttr,  
  TxOptions  
}
```



0x01 = Broadcast Flag  
0x02 = Security Flag

# 4.1.2.3 Data Scheduling

# Packet Pending Queue

- The NCAP can put up to seven WTIM addresses of the pending packets in the “address list” field of its beacon packets.
- If the NCAP needs to support more than seven WTIMs, the “address list” field cannot accommodate the addresses of all pending packets.
- We build a pending packet queue (PPQ) in the LAM layer to store these excess packets and sequentially push them to the “address list” field of the beacon packets .

# Packet Pending Queue (Cont.)

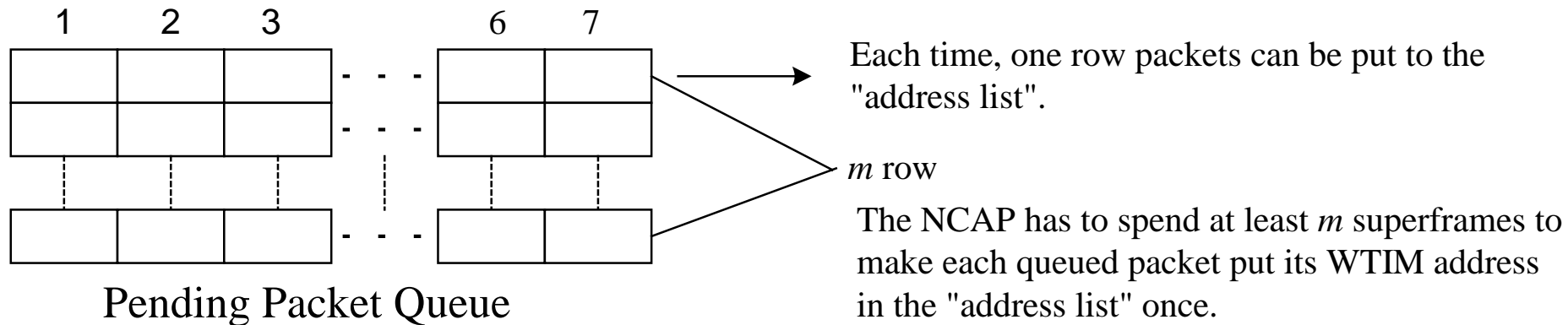

Since each queued packet can only put its address in the address list every  $m$  superframes, one WTIM, when wakes up, has to scan at least  $m$  superframe beacons to determine whether or not it has pending packet in the NCAP. The parameter  $m$  is put in the "beacon payload" to be accessed by all awake WTIM.

If the NCAP has the prior knowledge of the WTIMs' wake-up time, it can smartly sort the queued packets by the WTIMs' wake-up time for higher efficiency.

# Priority Consideration

We classify the packets from the NCAP into three priority levels:

- High priority packets have their whole contents included in the beacon payload so that the addressed WTIMs can catch them immediately.
- Medium priority packets have their WTIM addresses included in each beacon payload without queuing with the low priority packets in the PPQ.
- Low priority packets only wait at the PPQ and be placed in the address list in turn.

# GTS Support

- When the LAM layer of one WTIM receives a *LD-DATA.request* primitive (or a data packet from the MAC layer) with the “GTS flag” set as 1, it immediately generates a *MLME-GTS.request* to apply for a position in the CFP of the NCAP superframe.
- If the GTS request is approved by the NCAP, it uses the allocated GTS to periodically transmit (or receive) data packets with guaranteed QoS.
- This function is especially useful for the instant transmission of large batch of packets between the NCAP and WTIMs.

## 4.1.2.4 Batch Packet Delivery

- When the NCAP LAM accumulates more than one packets from the application layer destined to a same WTIM, it can assemble these packets to the payload of a single MAC frame, and send them out at one time.
- In the WTIM side, the large payload of the MAC frame is disassembled in the WTIM LAM and recovered to original packets that are then sent up to the application layer of the WTIM one by one.
- If one MAC frame is not large enough to include all the packets, more than one MAC frame are used. All MAC frames except the last one have their “frame pending” subfield set to 1 to make the WTIM request the frames continuously without waiting for new beacons.

# 4.1.2.5 Reliable Broadcasting /Multicasting

# Applications of Reliable Broadcast/Multicast

- NCAP sending global triggers, controls and commands to all/multiple WTIMs;
- NCAP sending re-programming files to all/multiple WTIMs.

# Assumptions

- WTIMs may go to sleep in order to save power. Each WTIM should inform the NCAP about its sleeping period and next wake up time during the setup procedure; WTIMs should also inform the NCAP once their sleeping period or scheduled wake up time have been changed.
- Once wake up, a WTIM should receive at least one beacon signal before entering next sleeping period;
- By collecting sensor information in TEDS format, NCAP has the knowledge of all the WTIMs and their sensors;

# Challenges

- WTIMs may be in sleeping mode when a broadcast packet is sent;
- IEEE 802.15.4 is designed to favor battery powered devices which will be in sleep state most of the time. Data sessions are assumed to be initiated by devices, not the coordinator;
- Broadcasting is not naturally supported in IEEE 802.15.4.

# Broadcasting by using the Beacon frame

<b>Octets: 2</b>	<b>1</b>	<b>3/4/10</b>	<b>2</b>	<b>1</b>	<b>variable</b>	<b>variable</b>	<b>2</b>
Frame control	Sequence number	Addressing fields	Superframe specification	Pending address specification	Address list	Beacon payload	Frame check sequence
MAC header			MAC payload				MAC footer

- In IEEE 802.15.4, only the Beacon signal is broadcasted without contenting with other communications.
- The broadcast packet will be put in the “Beacon payload” field;
- If a WTIM receives a beacon with a payload field present, it shall indicate it to the DME and then LAM will process it and response with an Acknowledgment packet (as a Data generated at WTIM) to confirm the reception of the broadcast packet.

# Communication from a coordinator in a beacon-enabled network

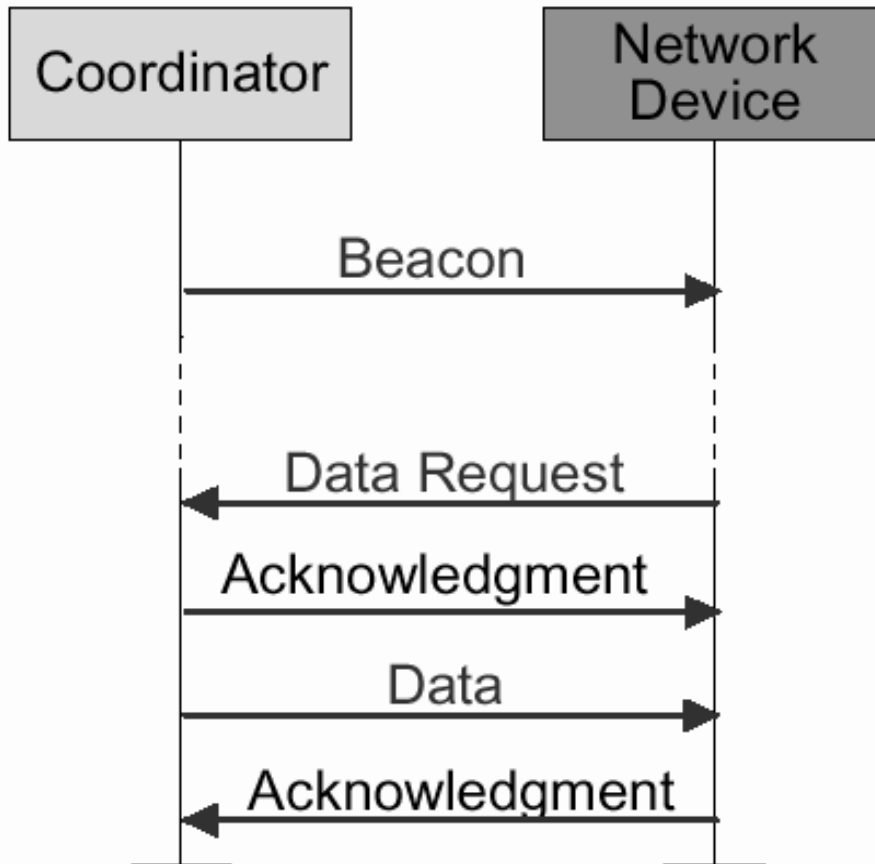

- If we use the “Pending Address List” field in the beacon frame, the receivers will automatically send a “Data Request” to the coordinator if they are in the list. Then it becomes multiple unicast because the coordinator will response to each receiver respectively.
- Apparently this is not a good way of doing broadcasting.

# Communication to a coordinator in a beacon-enabled network

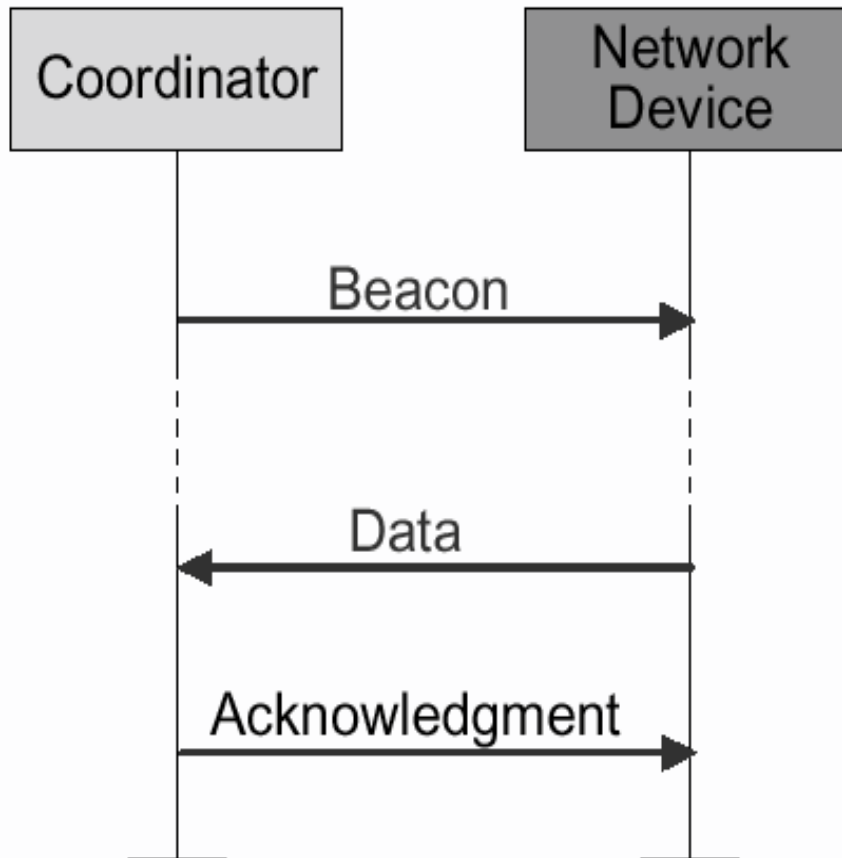

- It is natural to follow this procedure to broadcast a packet;
- Packets can be broadcasted using the payload field of beacon;
- The ACK of broadcast packet can be treated as “Data” (with “ack.req” bit set to “0”, the Acknowledgment from coordinator can be saved)

# Broadcast Period (BP)

- Broadcast Period is defined as the time period during which the coordinator shall keep on sending the same broadcast packet in the beacon frames;
- BP is determined by examining the sleeping period of each device – it will be set to the longest reasonable sleeping period among all devices (devices with extremely long sleeping period will not be considered when determining the value of BP);
- A threshold can be set to represent the BP.

# Broadcast Operation

1. The NCAP determines the number of WTIMs in the network and the Broadcast Period (BP);
2. The NCAP starts broadcasting the packet in every beacon signal using “*Beacon payload*” field until the number of WTIMs which have not acknowledged the broadcast packet (UnAckedWTIM), is less than or equal to 7;
3. When the number of UnAckedWTIM is  $> 7$ :
  - Upon receiving the packet, WTIM composes an acknowledgement at DME and sends this ACK via Data frame at MAC layer;
4. When the number of UnAckedWTIM is  $\leq 7$ :
  - Broadcast packets will no longer be sent by using the payload field of the beacon. Instead, they will be sent by putting the addresses of the devices which have not sent the acknowledgments in the *Pending Address List* of the beacon. The communication procedure illustrated in slide 5 will be used to pull these nodes to request the sending of packets from NCAP to WTIMs;
5. This process stops when either the BP is reached or all of the WTIMs ACK the packet. If the NCAP has not heard all the acknowledgments from the WTIMs when the BP is reached, a list of nodes which have not sent the ACK will be put in the *Pending Address List* and Step 4 will be followed to deliver the packet.

# Message Sequence of Broadcast Packet

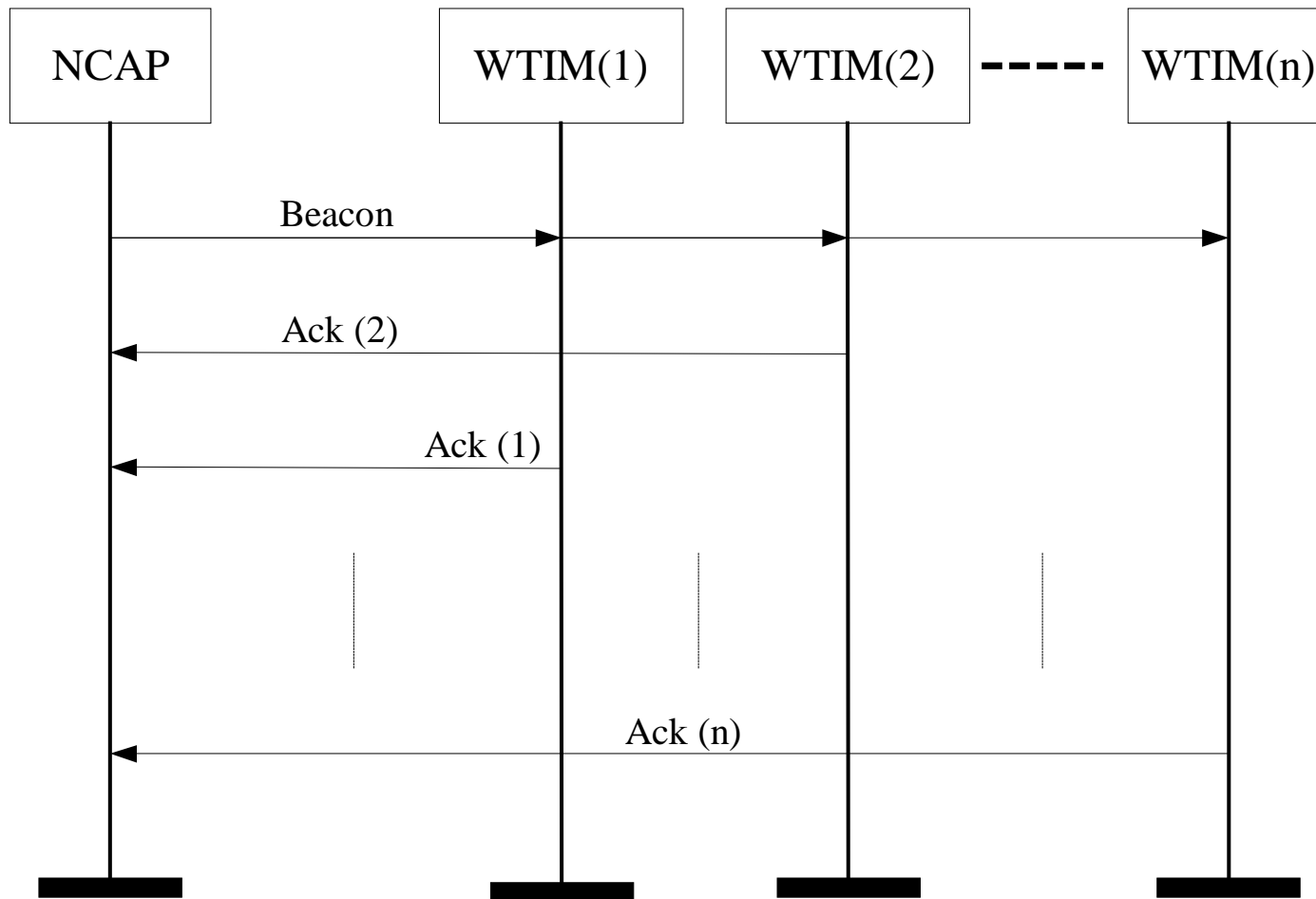

# Multicasting

- Multicasting is sometimes needed to transmit messages from the NCAP to a group of WTIMs. For instance, a trigger signal needs to be sent to all WTIMs which contain temperature sensors.
- This project only considers multicasting among homogeneous WTIMs/Sensors, i.e. only WTIMs contain same kinds of sensors can be in the same group.
- Multicasting is done by broadcasting the packet with an attribute specified (e.g. temperature) at the MAC and PHY layer.
- Upon receiving the packet, WTIMs check their local information to see whether they belong to the multicast group. If yes, an acknowledgment packet will be sent back to NCAP.

## 4.2 LAM Packet Formats

## 4.2.1 General Packet Formats

<b>Octets: 2</b>	<b>1</b>	<b>variable</b>
Packet Control	Sequence Number	Packet Payload
LAM Header		LAM Payload

**General LAM Packet Format**

<b>bits:0-1</b>	<b>2</b>	<b>3-7</b>	<b>8</b>	<b>9</b>	<b>10</b>	<b>11-15</b>
Packet Type	Broadcast Indication	Attr.	Ack. Req	Packet Pending	GTS Flag	Reserved

**LAM Packet Control Field**

# Packet Type Field

<b>Packet Type Value</b>	<b>Description</b>
00	Data
01	Acknowledgment
10	Command
11	Reserved

## 4.2.2 Data Packet Format

<b>Oct et s: 2</b>	<b>1</b>	<b>var i bl e</b>
Packet Cont r ol	Seqence Number	Dat a Payl oad
LAM Header		LAM Payl oad

**LAM Data Packet Format**

## 4.2.3 ACK Packet Format

<b>Oct et s: 2</b>	<b>1</b>
Packet Cont r ol	Seqence Number
LAM Header	

**LAM ACK Packet Format**

## 4.2.4 Command Packet Format

<b>Octets: 2</b>	<b>1</b>	<b>1</b>	<b>variable</b>
Packet Control	Sequence Number	Command Identifier	Command Payload
LAM Header		LAM Payload	

### LAM Command Packet Format

# LAM Command Packet

Command Identifier	Command
0x01	LLME-SERVICE
0x02 - 0xff	Reserved

Reserved fields will be used to provide higher layer services, such as routing, pairing etc., which are not supported by MAC services.