

# Update of IEEE P1500 Core Wrapper Architecture

Presented by  
Lee Whetsel  
on behalf of CTAG Working Group

International Test Conference  
October 7, 2002

# Topics

- Wrapper Overview & Applications
- Wrapper Architecture & Instructions
- Wrapper Harness Cells
- Summary

# Block Level Overview of a P1500 Wrapper

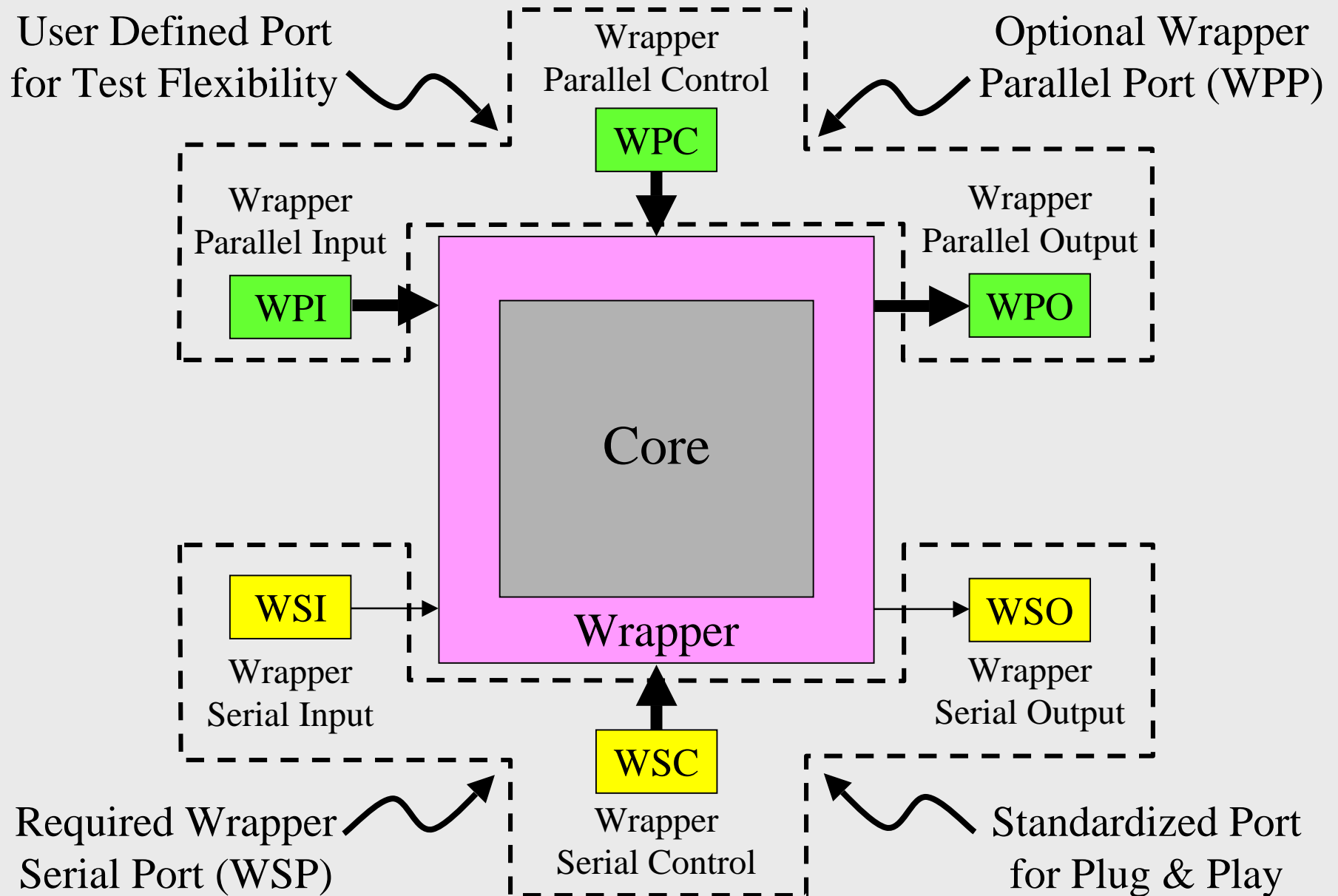

# P1500 Wrapper Configuration Examples

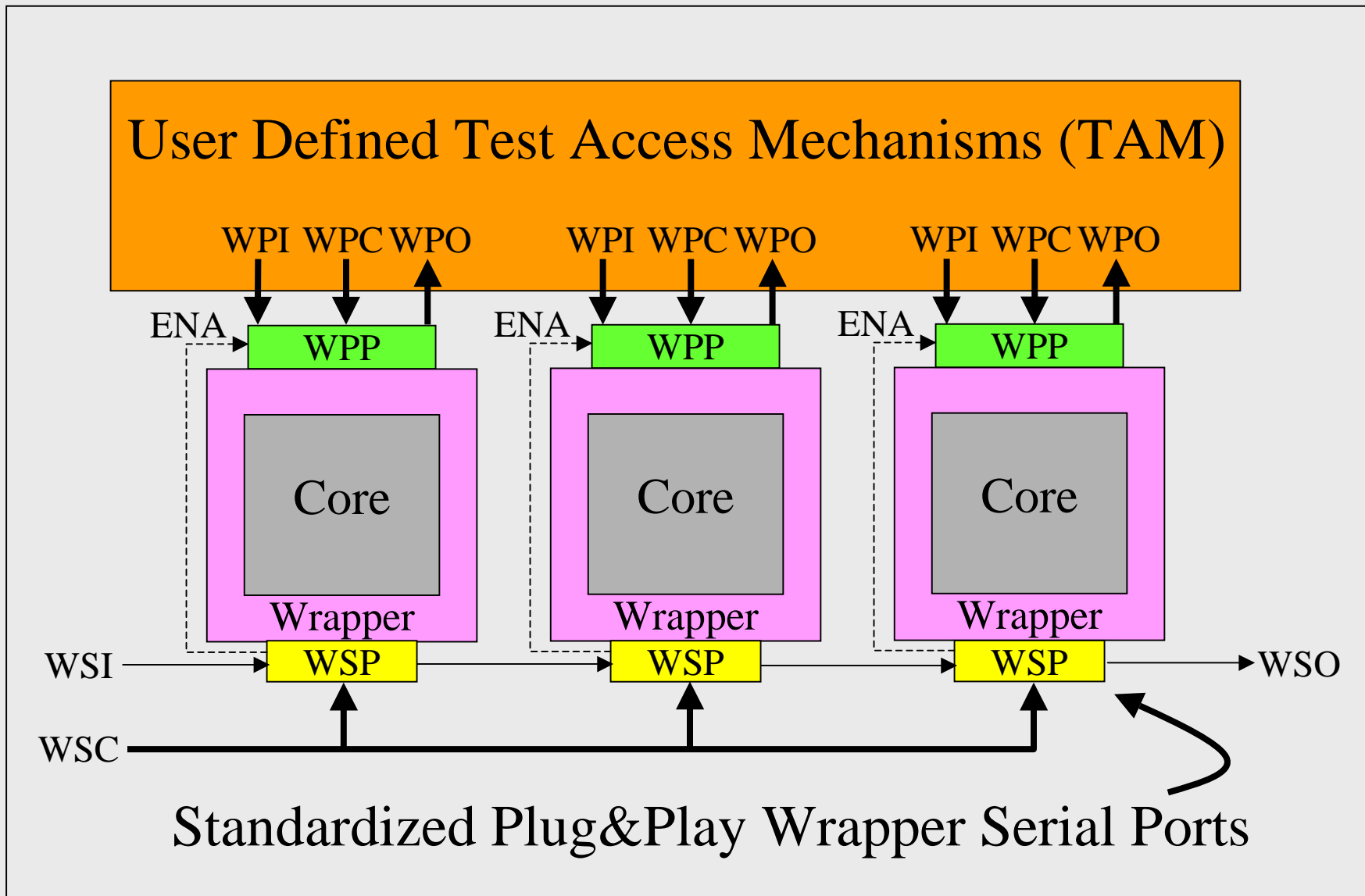

# P1500 Wrapper Configuration Examples

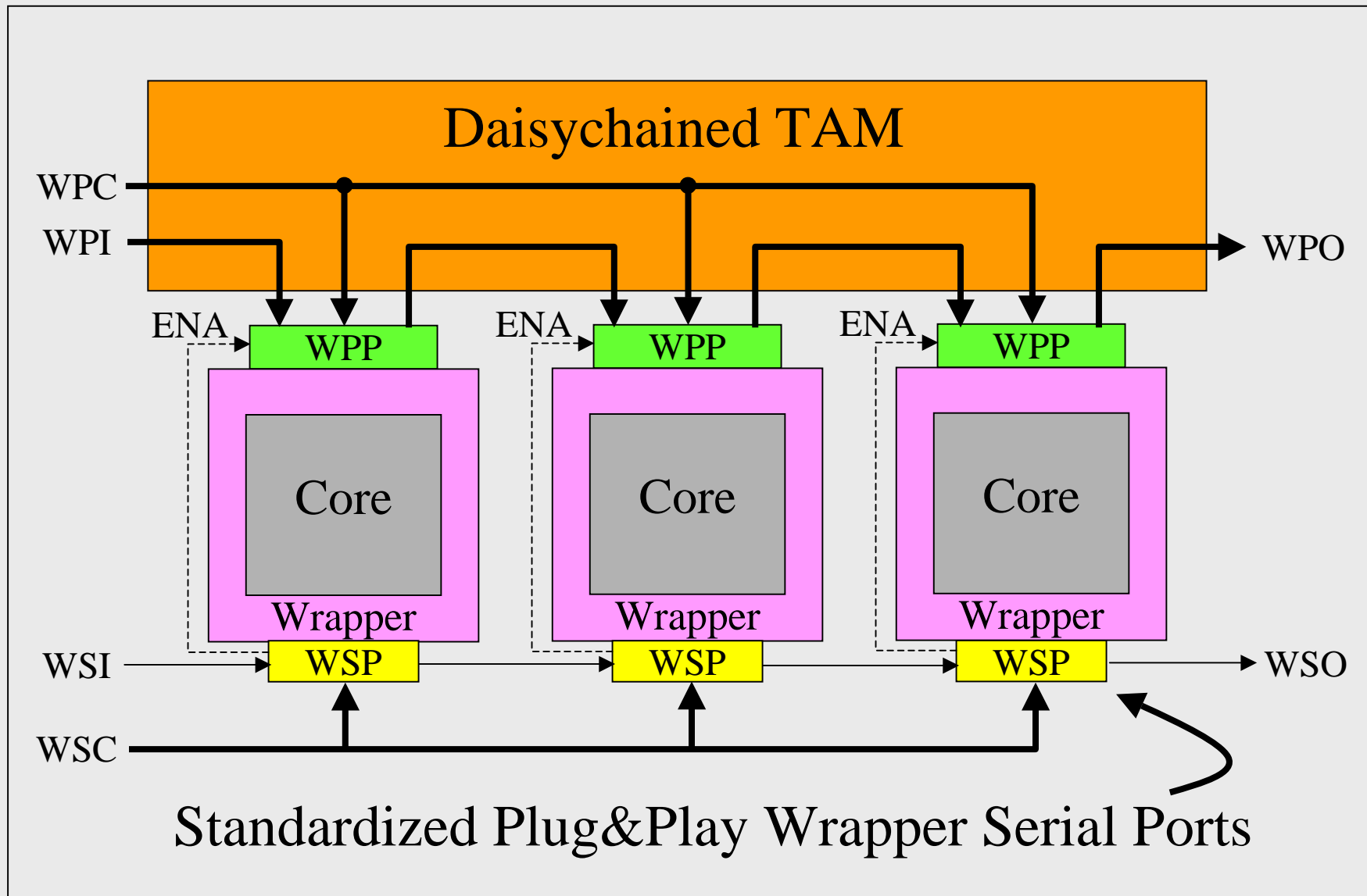

# P1500 Wrapper Configuration Examples

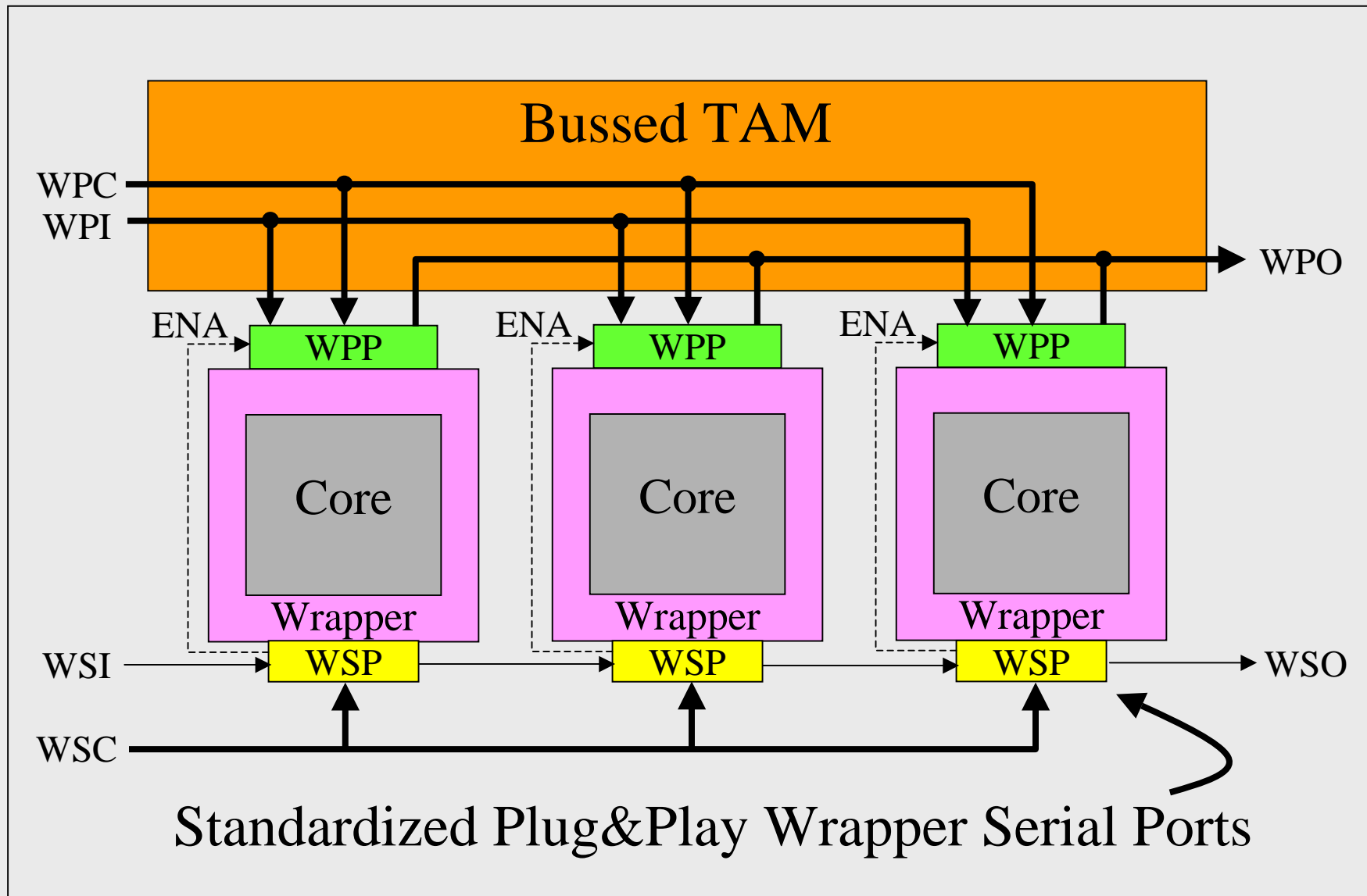

# P1500 Wrapper Configuration Examples

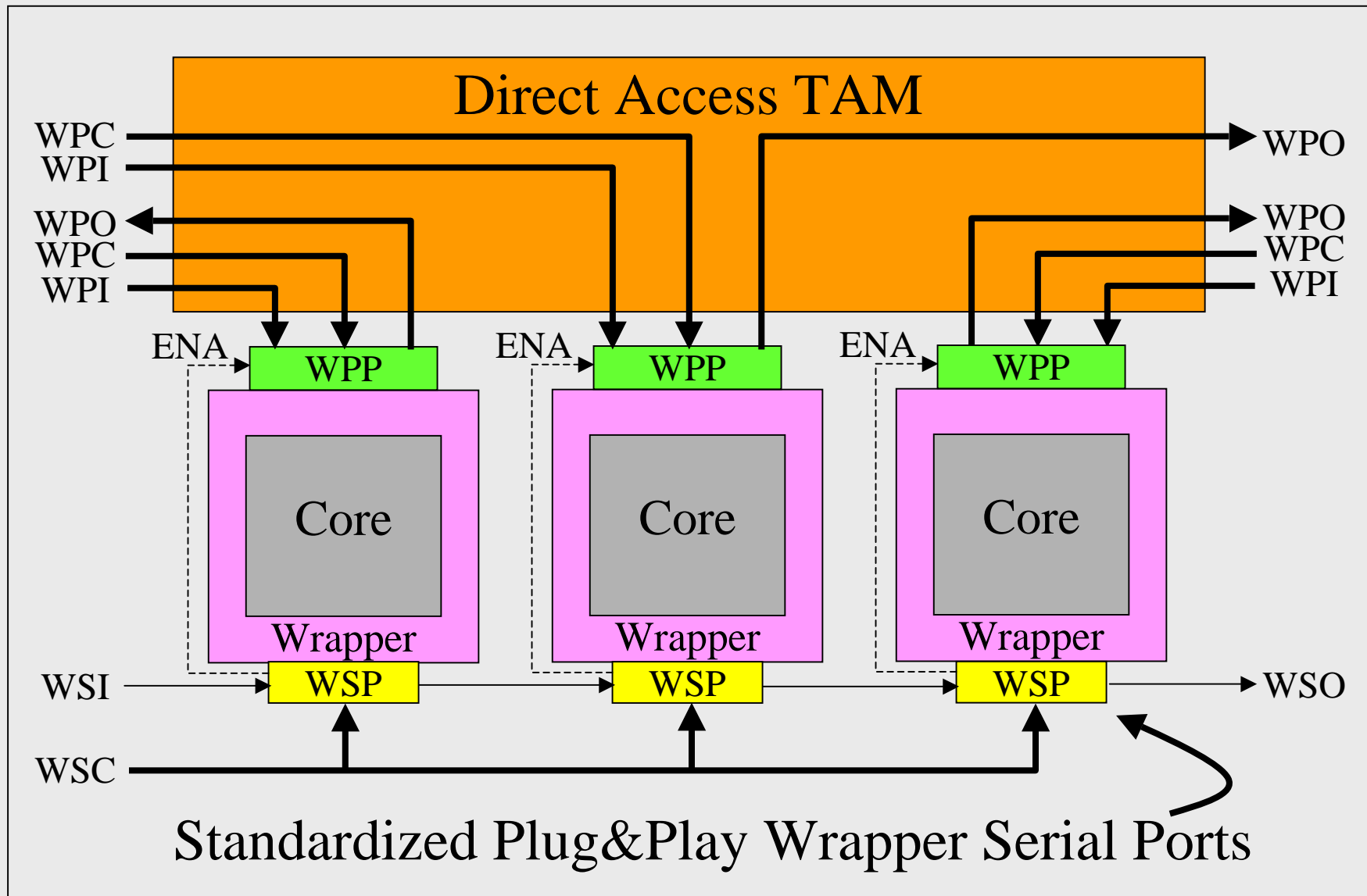

# P1500 Wrapper Configuration Examples

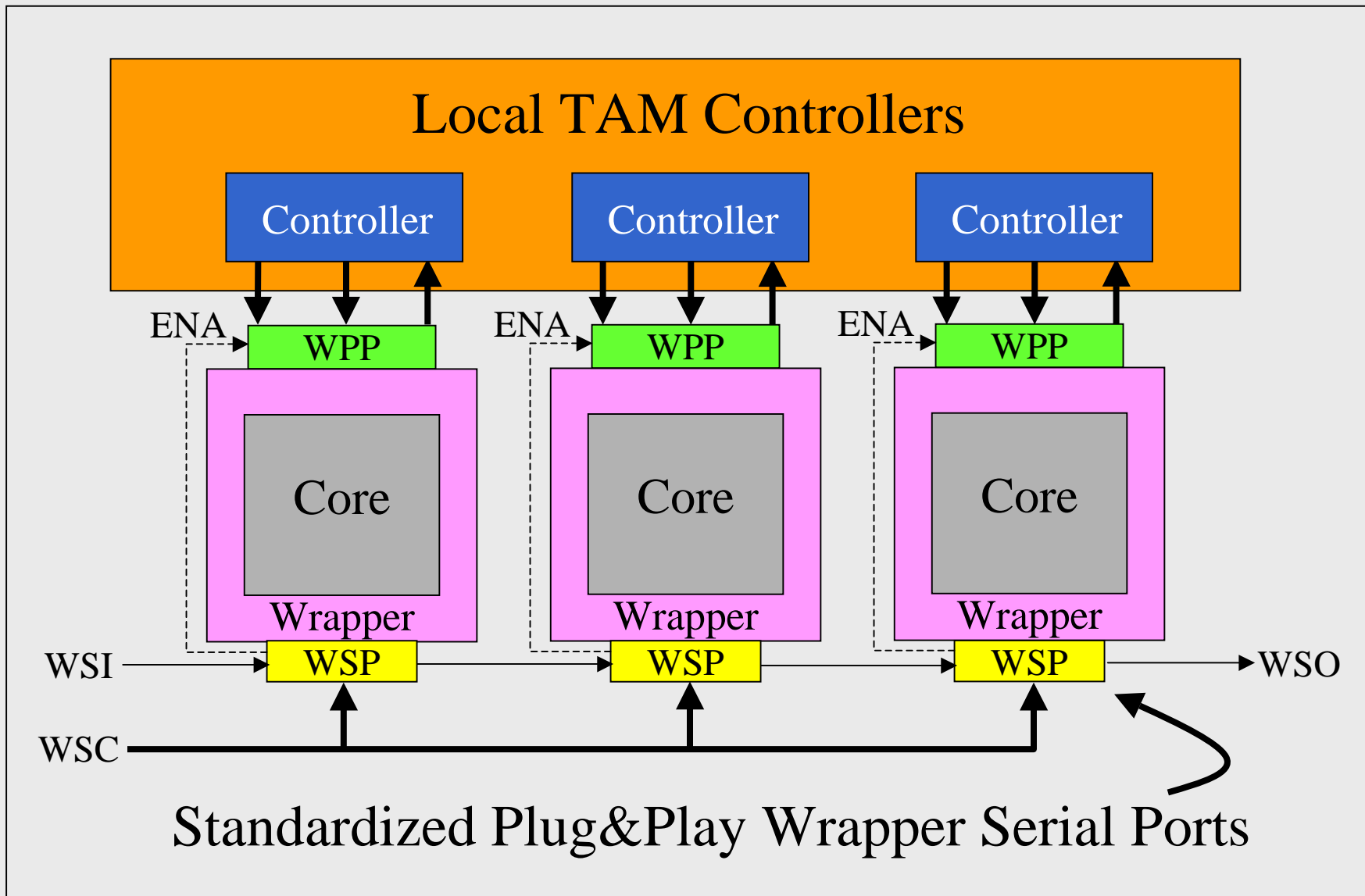

# Wrapper Architecture & Instructions



# P1500 Wrapper Test Instructions

<b>WS_BYPASS</b>	- <b>Required</b>	
WS_PRELOAD	- Optional	
WP_PRELOAD	- Optional	
W_CLAMP	- Optional	
W_SAFE	- Optional	
WS_INTEST_RING	- Optional	<b>At Least One Optional INTEST is Required</b>
WS_INTEST_SCAN	- Optional	
* WP_INTEST_RING	- Optional	
* WP_INTEST_SCAN	- Optional	
WH_INTEST	- Optional	
<b>WS_EXTEST</b>	- <b>Required</b>	
WP_EXTEST	- Optional	
WH_EXTEST	- Optional	

\* Under consideration as a Standard Optional Intest instruction

# P1500 Wrapper Test Instructions

Instruction	Controlling Port
WS_BYPASS	WSP
WS_PRELOAD	WSP
WP_PRELOAD	WPP
W_CLAMP	WSP
W_SAFE	WSP
WS_INTEST_RING	WSP
WS_INTEST_SCAN	WSP
* WP_INTEST_RING	WPP
* WP_INTEST_SCAN	WPP
WH_INTEST	WSP and/or WPP
WS_EXTEST	WSP
WP_EXTEST	WSP or WPP
WH_EXTEST	WSP and/or WPP

# Instruction Field Naming Conventions

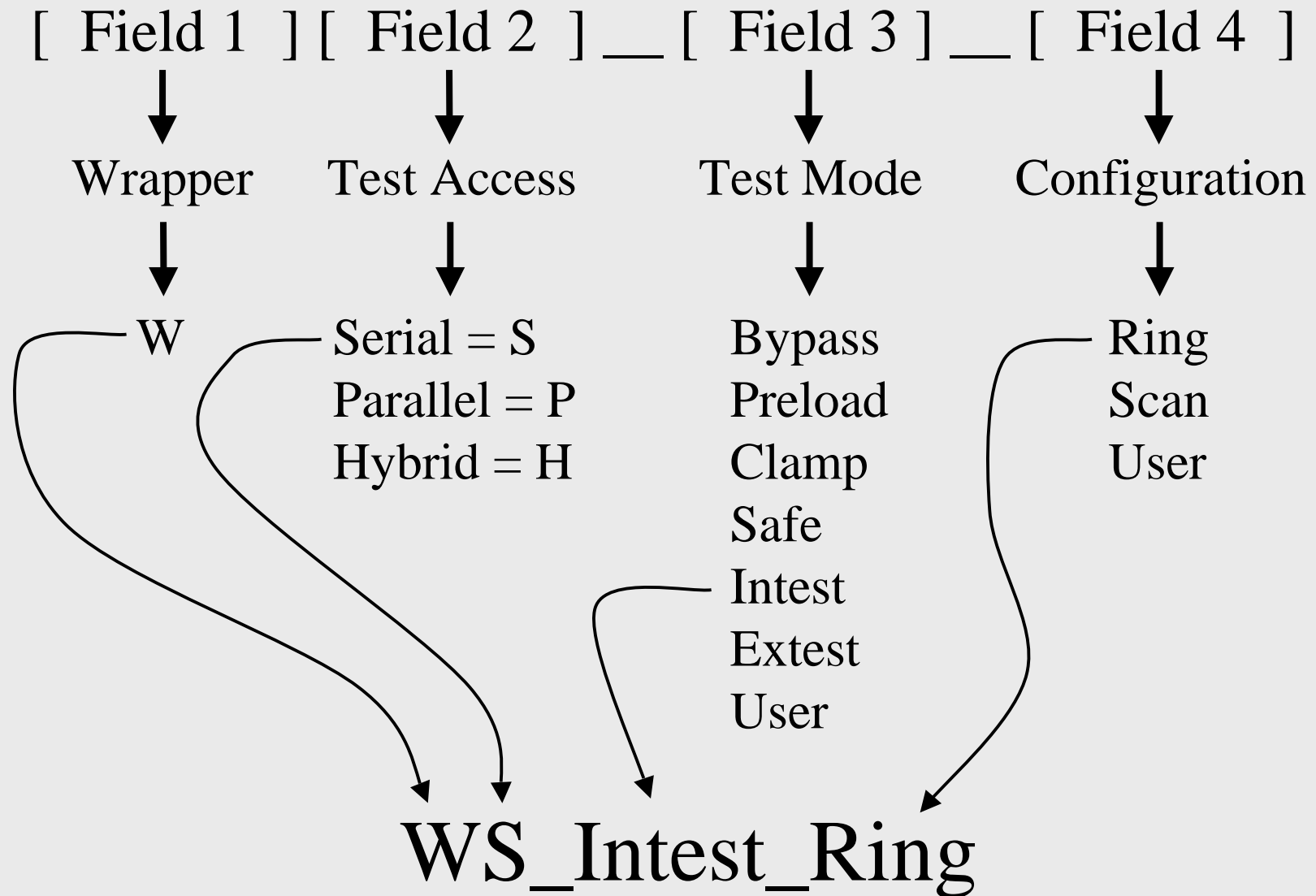

# Wrapper Serial Bypass (WS\_Bypass) Instruction

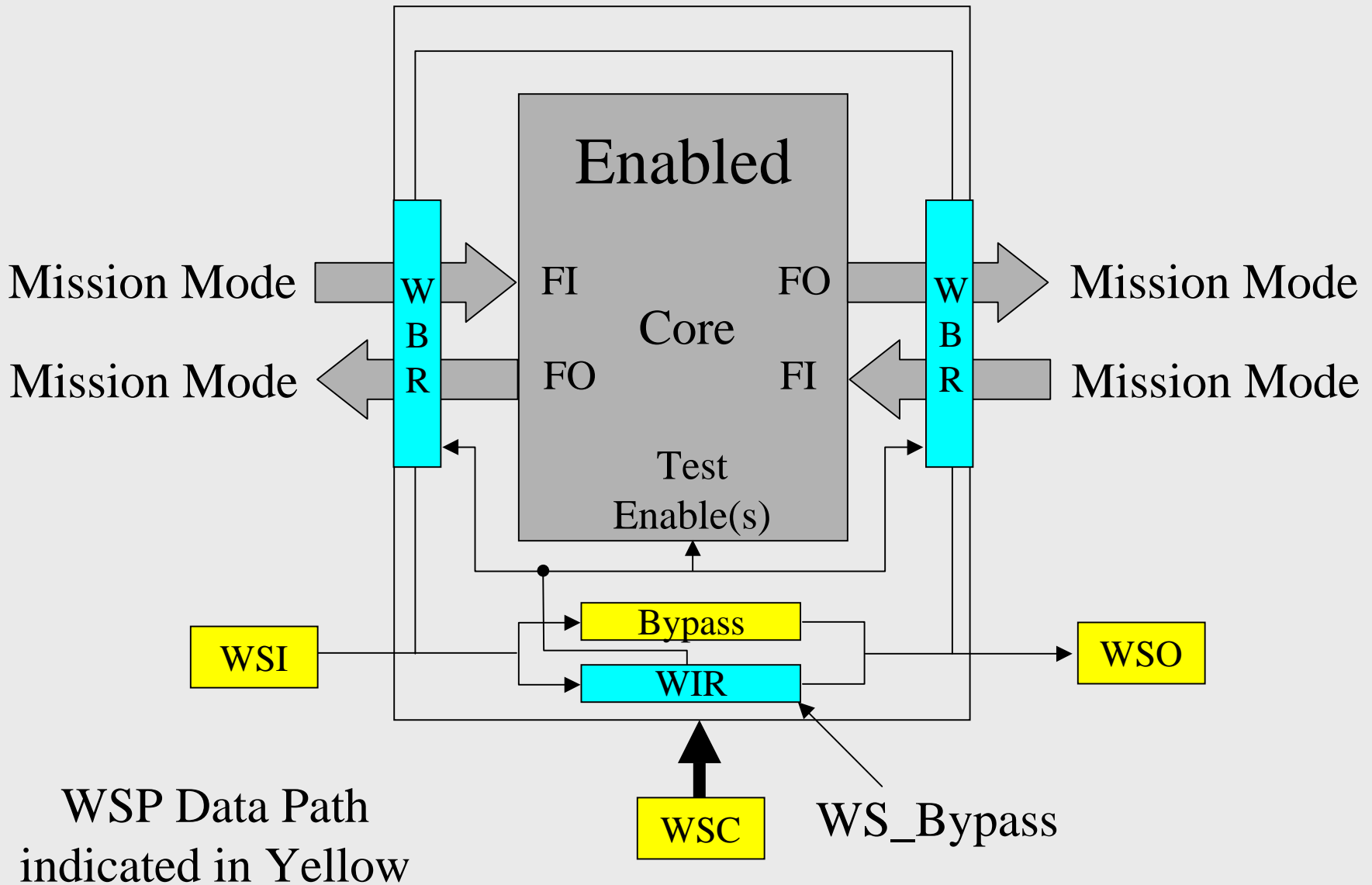

# Wrapper Serial Preload (WS\_Preload) Instruction

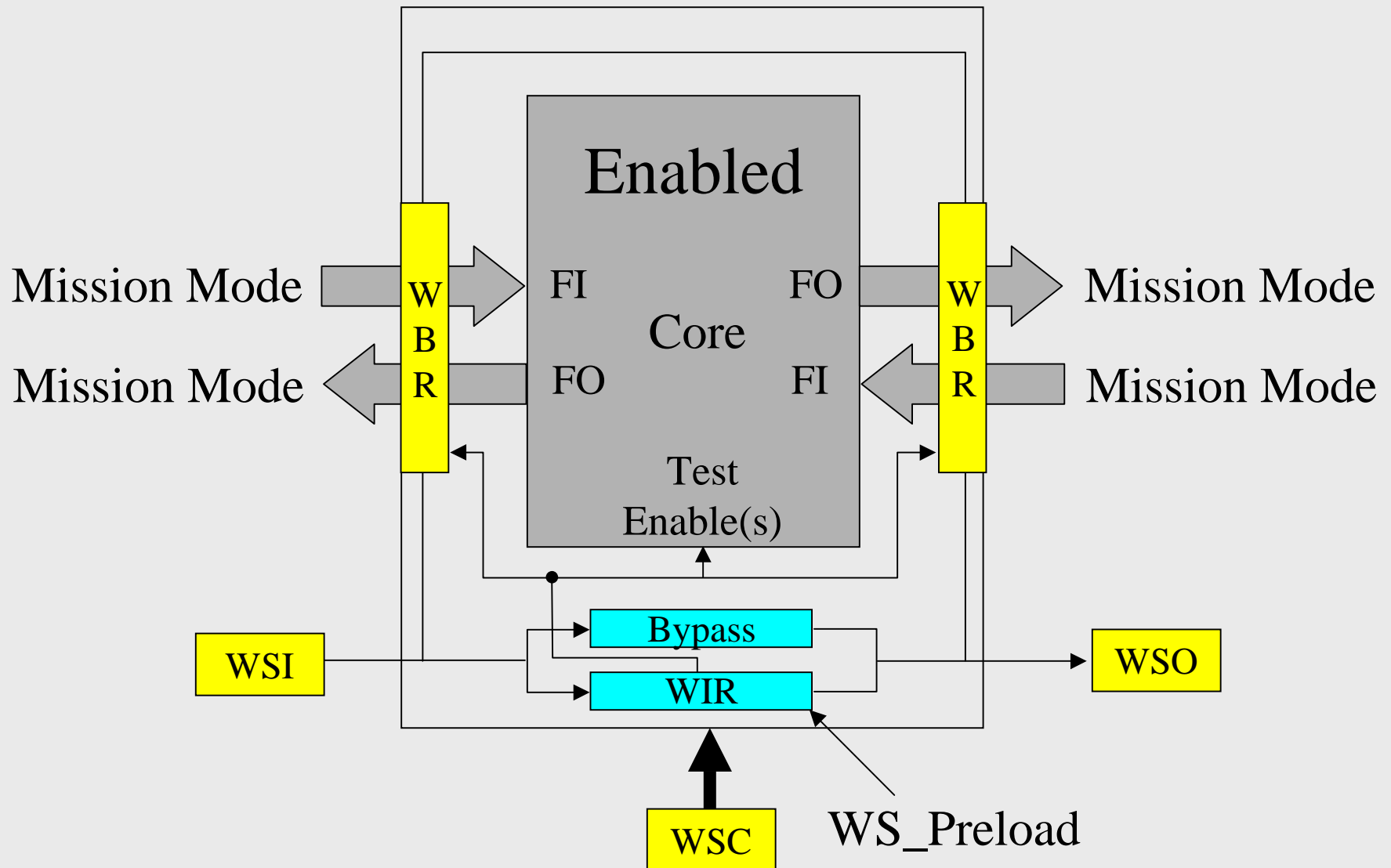



# Wrapper Clamp (W\_Clamp) Instruction

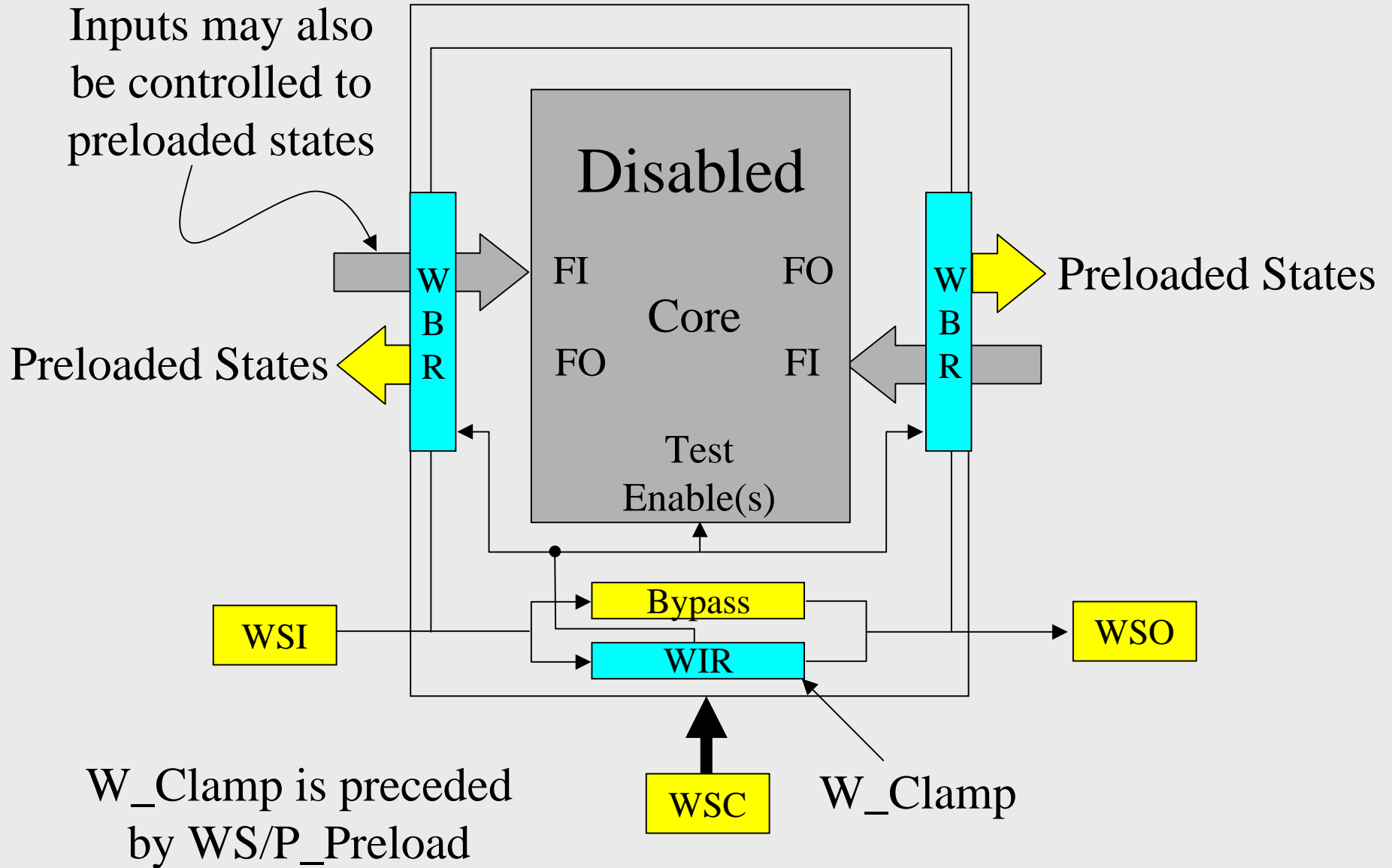

# Wrapper Safe (W\_Safe) Instruction

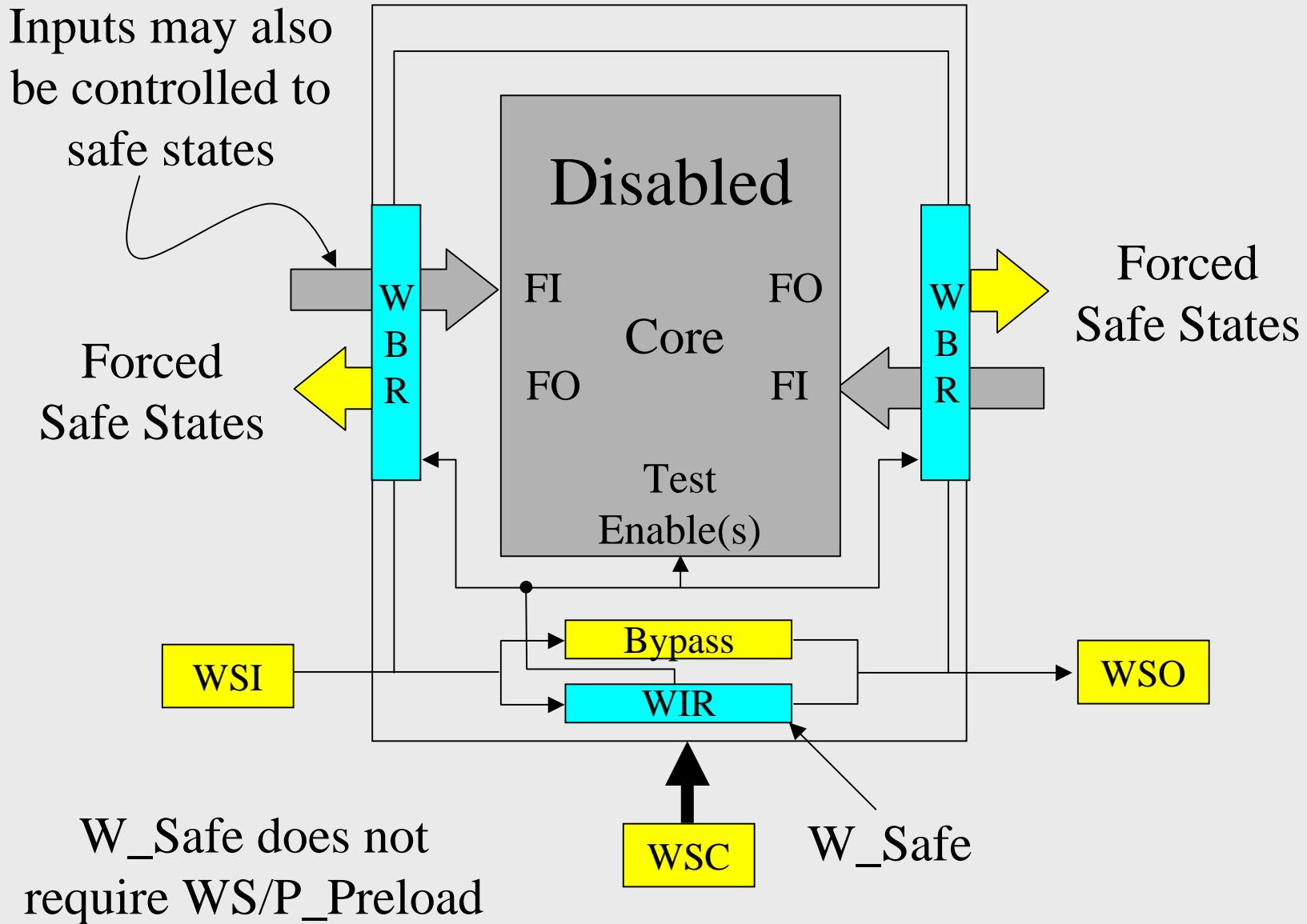





# Wrapper Parallel Intest Ring (WP\_Intest\_Ring) Mode

Test is applied  
via WPC Controlled  
WBR Segments

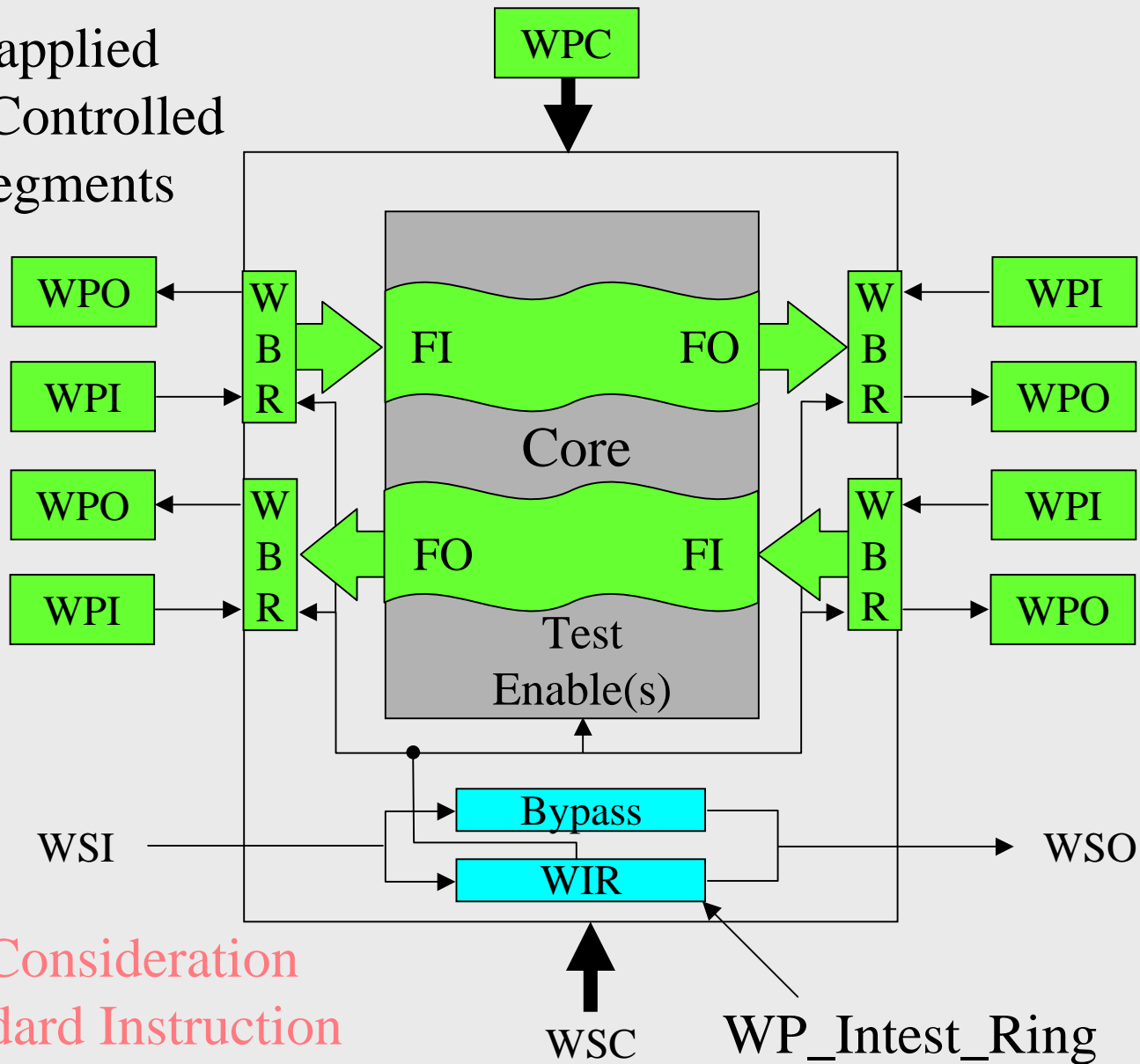

Under Consideration  
as a Standard Instruction



# Wrapper Hybrid Intest (WH\_Intest) Mode

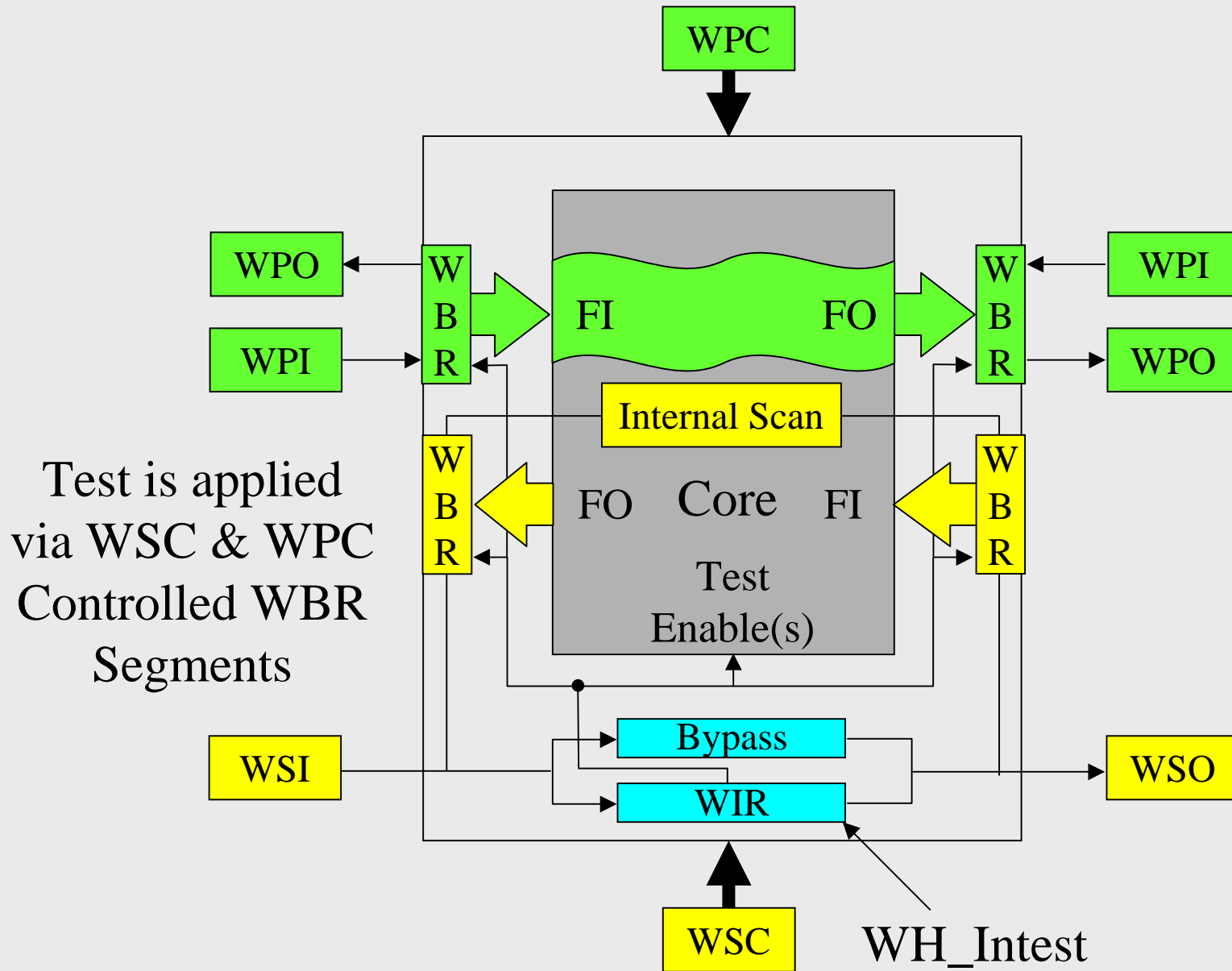

# Wrapper Serial Exttest (WS\_Exttest) Mode

Test is applied  
via WSC Controlled  
WBR Scan Path

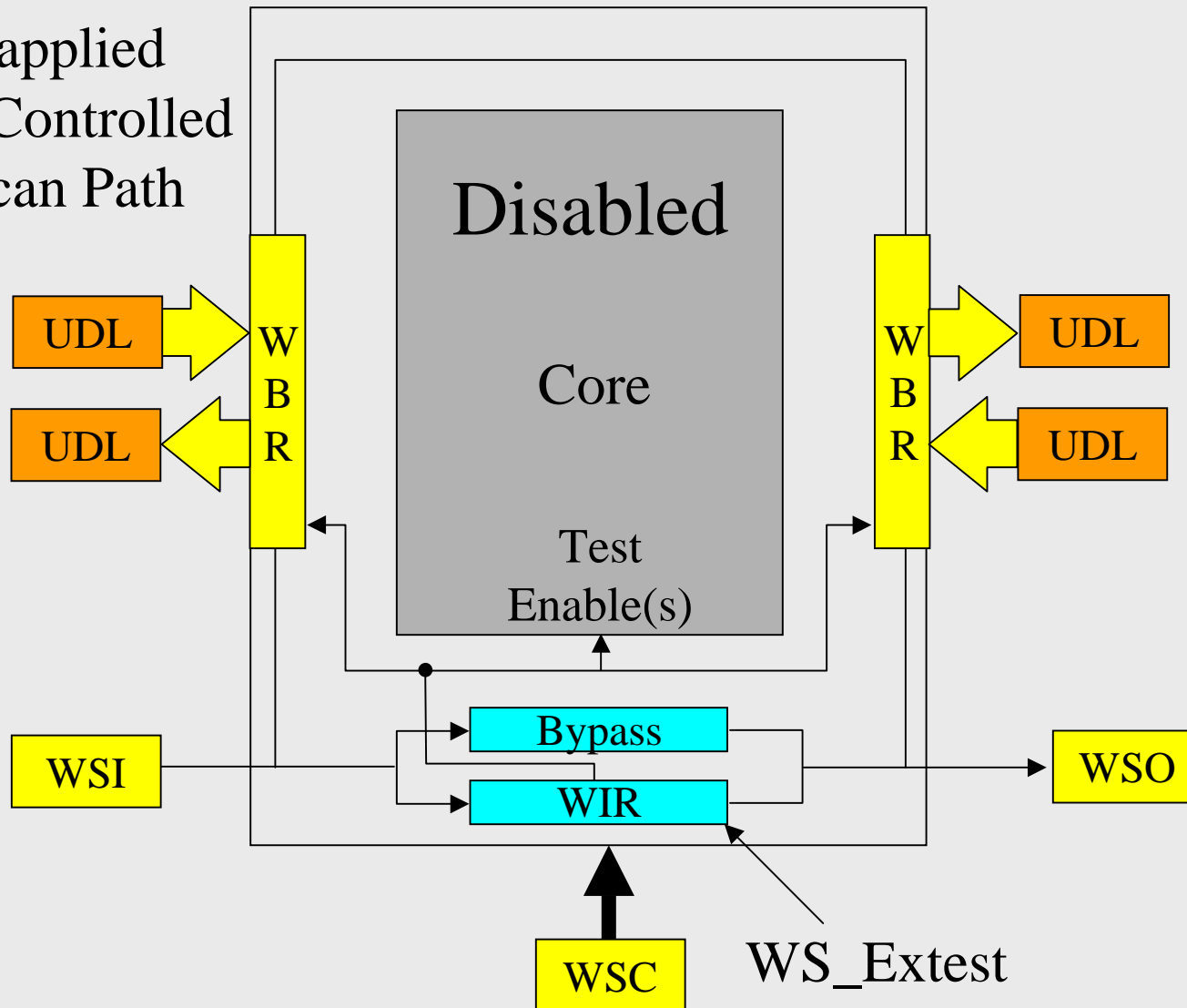

# Wrapper Parallel Exttest (WP\_Exttest) Mode

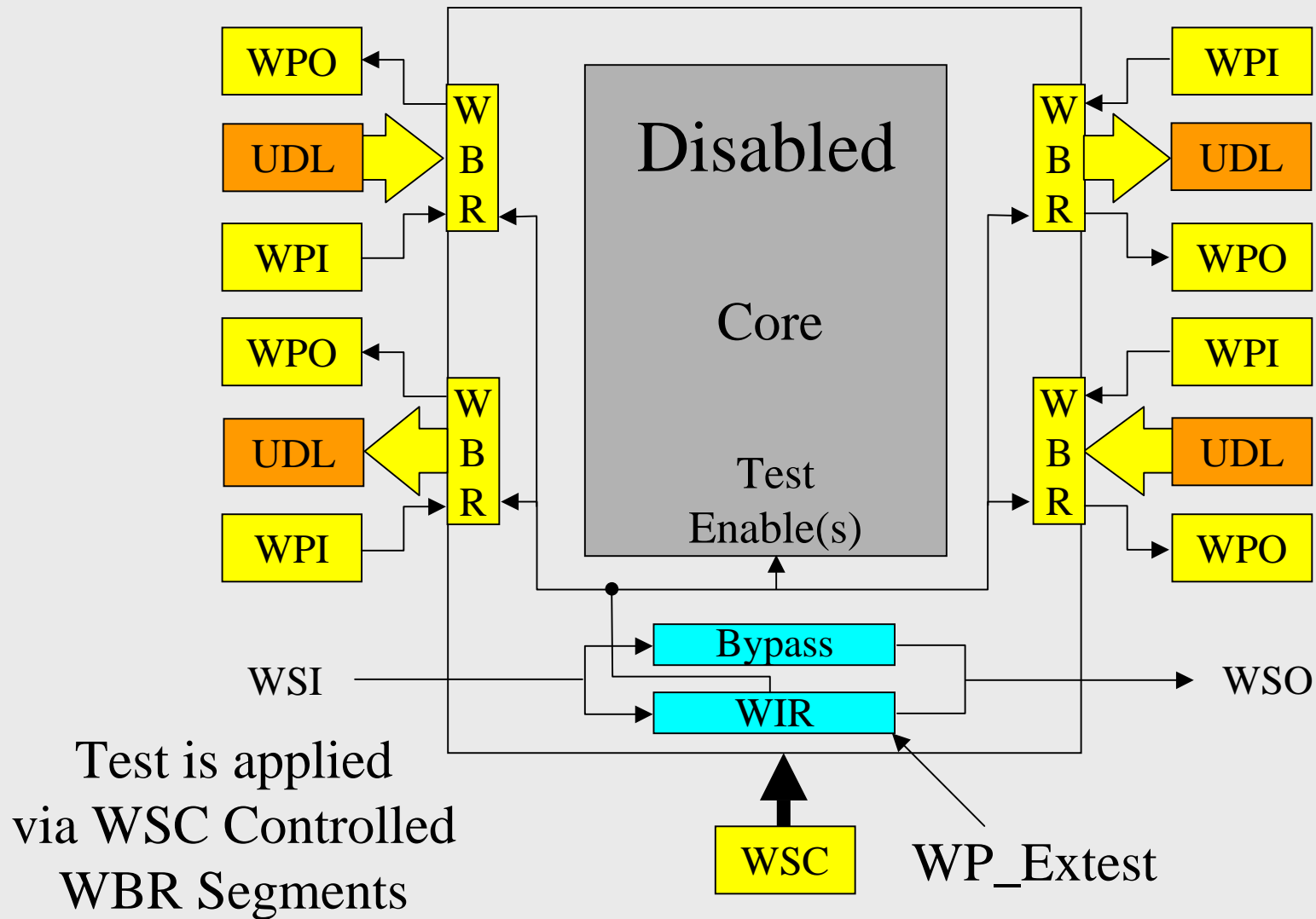

# Wrapper Parallel Exttest (WP\_Exttest) Mode

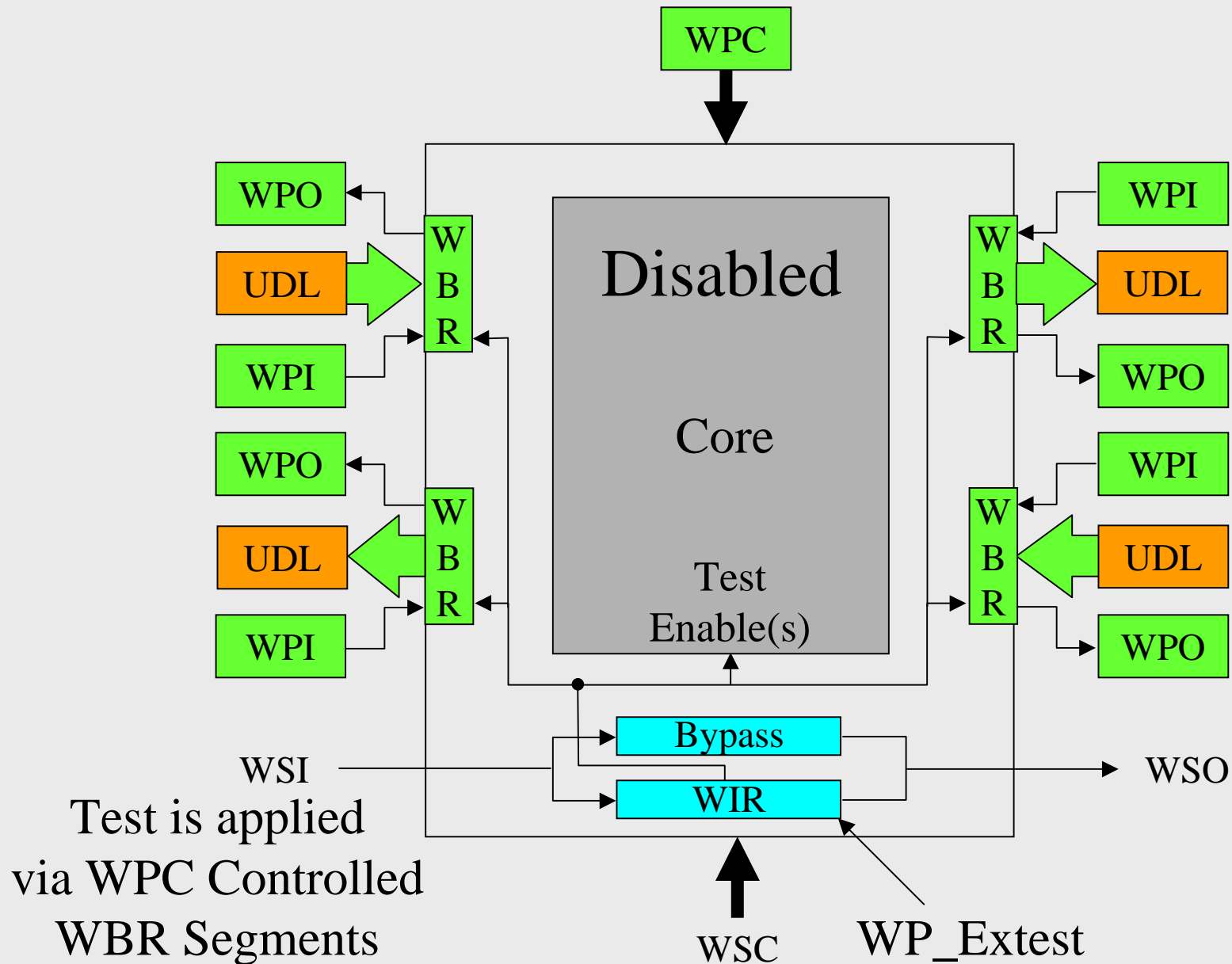

# Wrapper Hybrid Exttest (WH\_Exttest) Mode

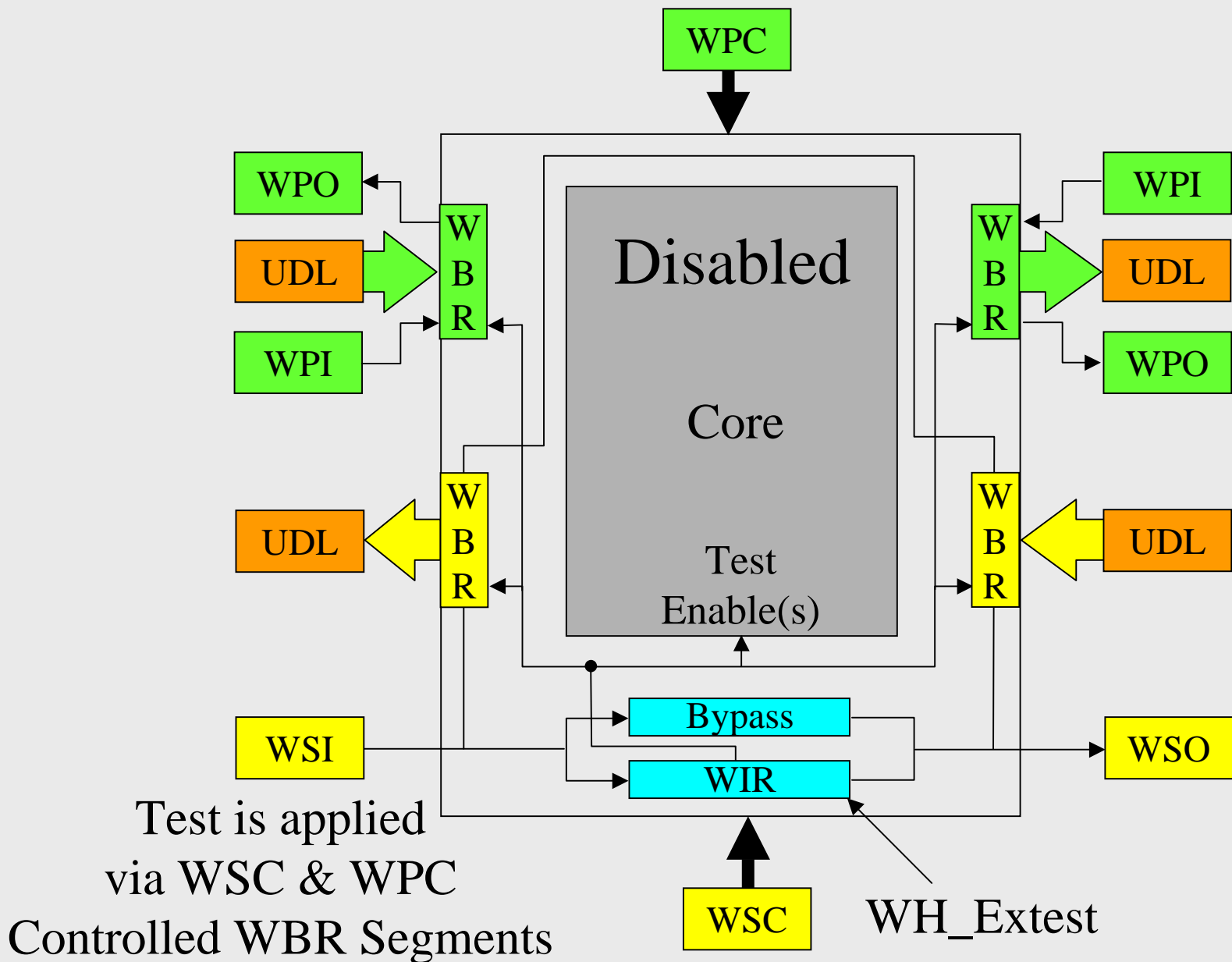

# Wrapper Harness Cells

# Applying Wrappers to Test Only Inputs & Outputs

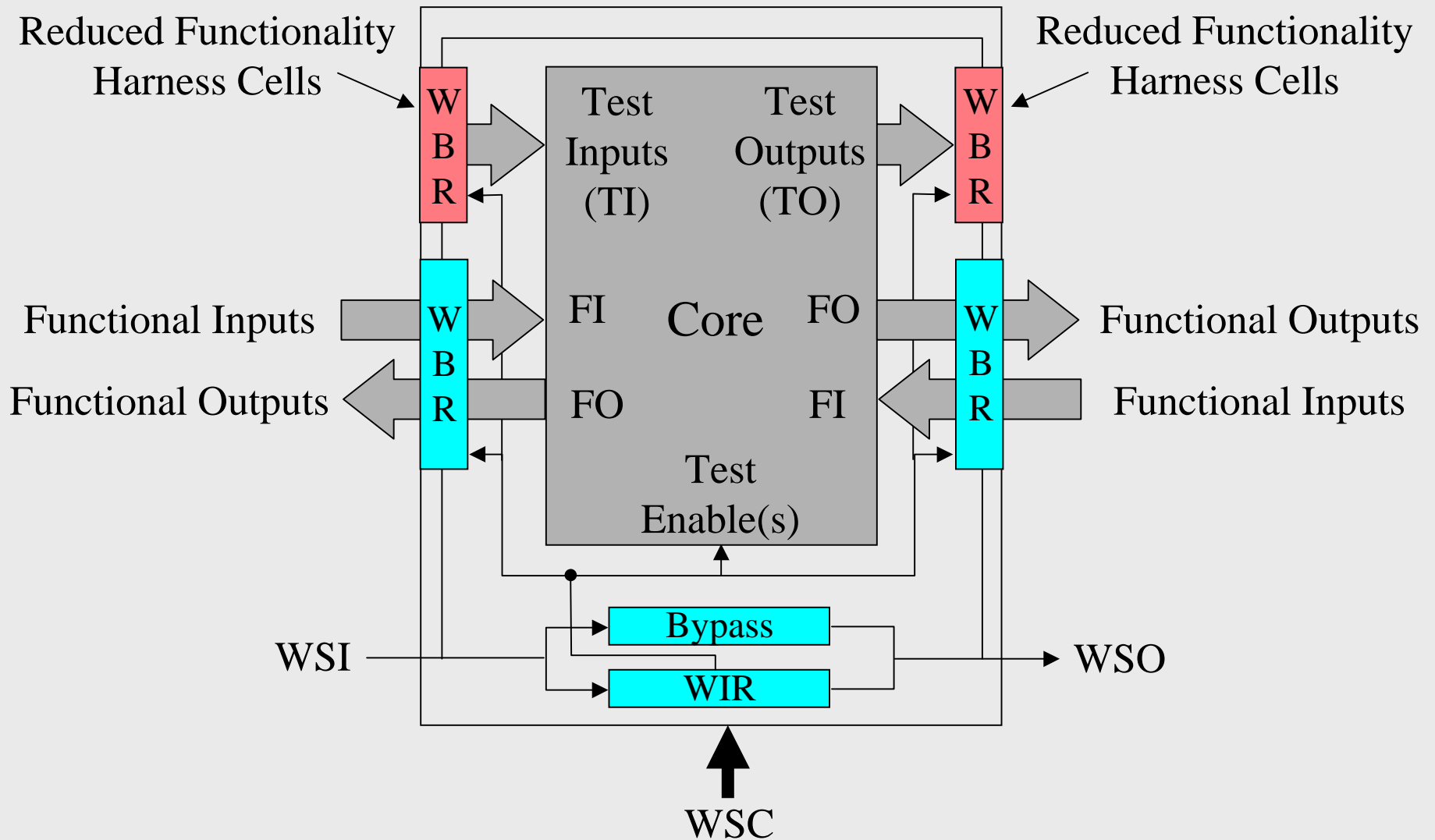

# Pass-Through Harness Cells

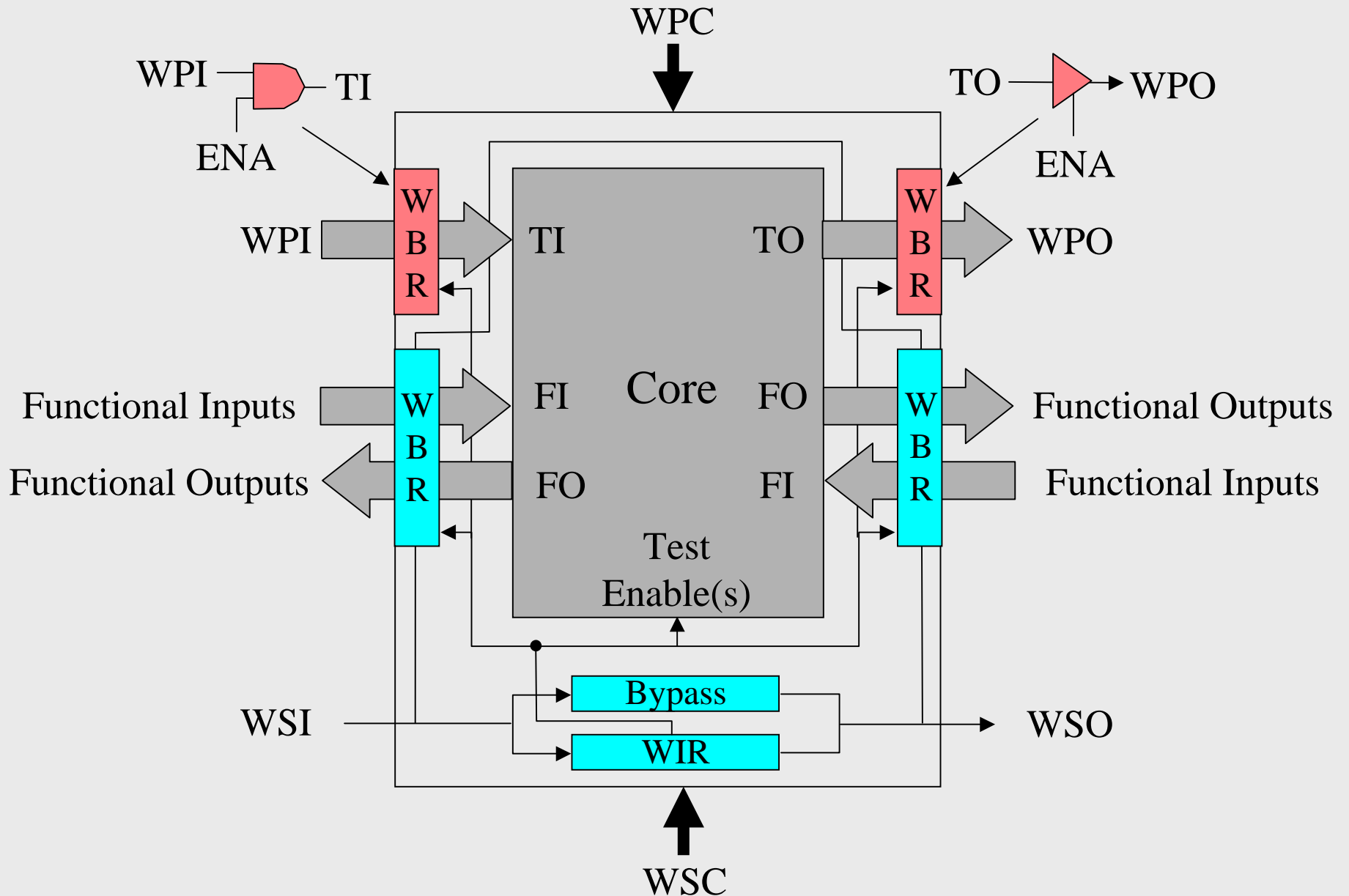

# Scan-Through Harness Cells

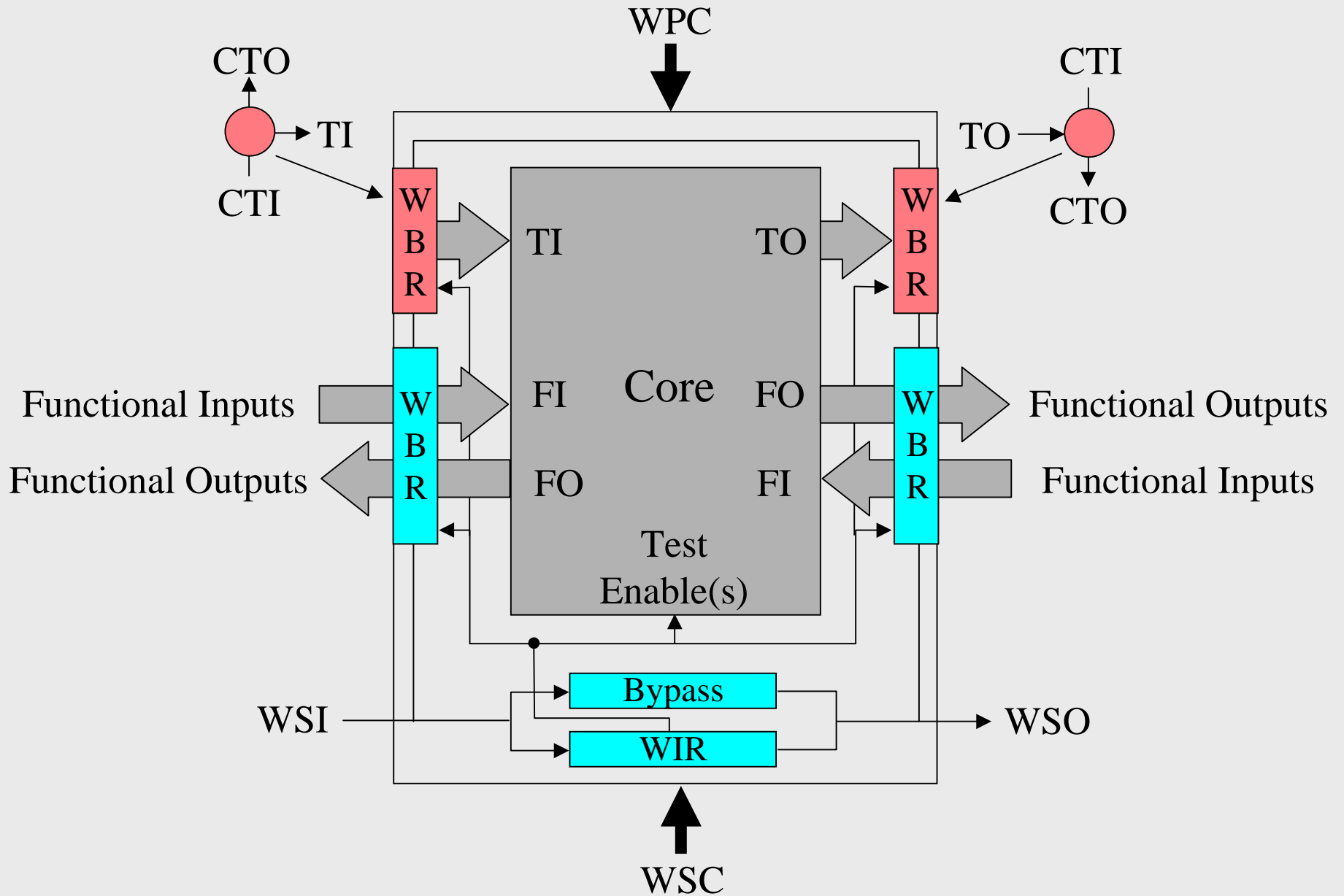

# Pass/Scan-Through Harness Cells

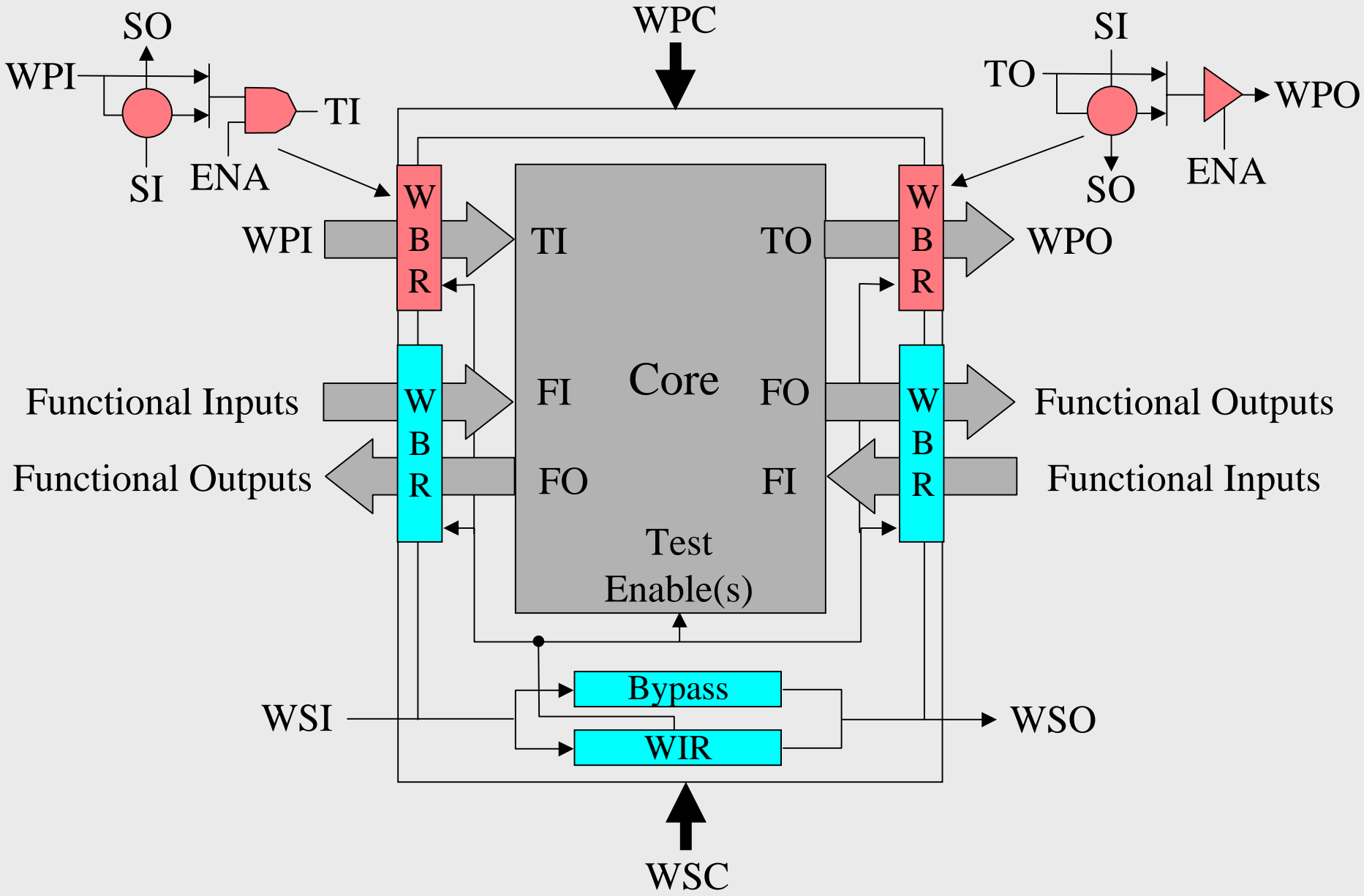

# Example Using Pass-Through Harness Cells

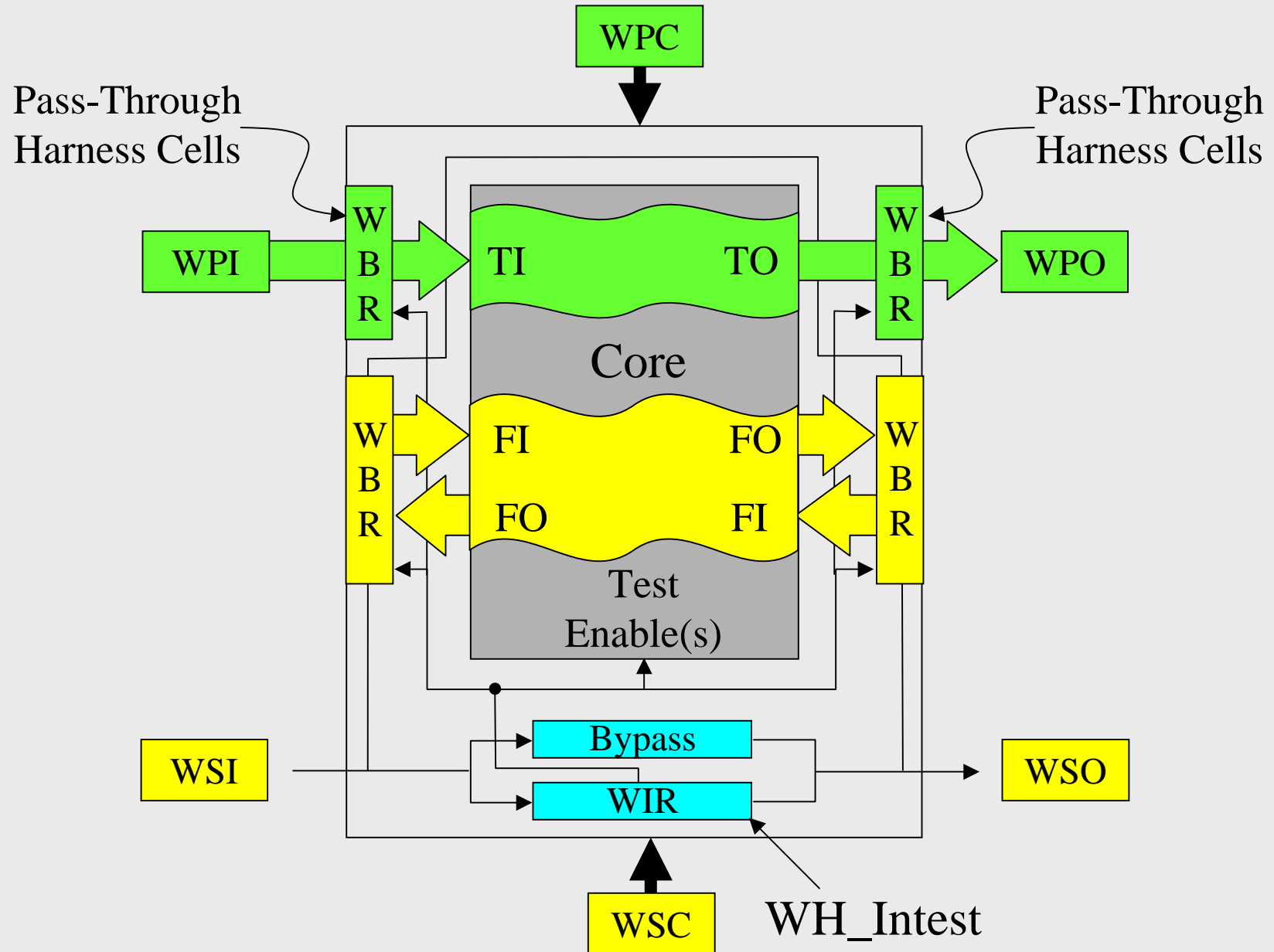

# Example Using Scan-Through Harness Cells

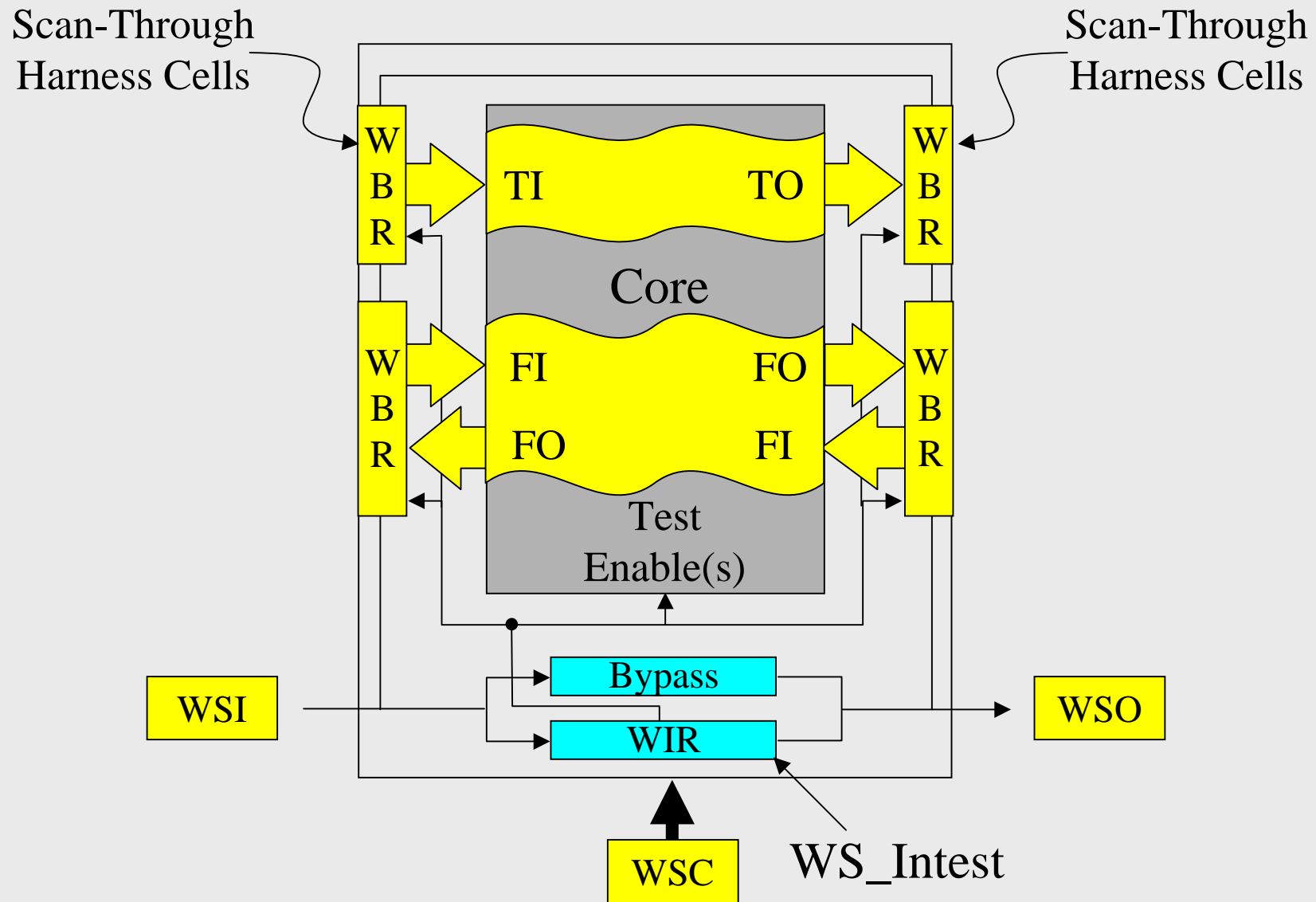

# Example of Pass/Scan Through Cells in Pass Mode

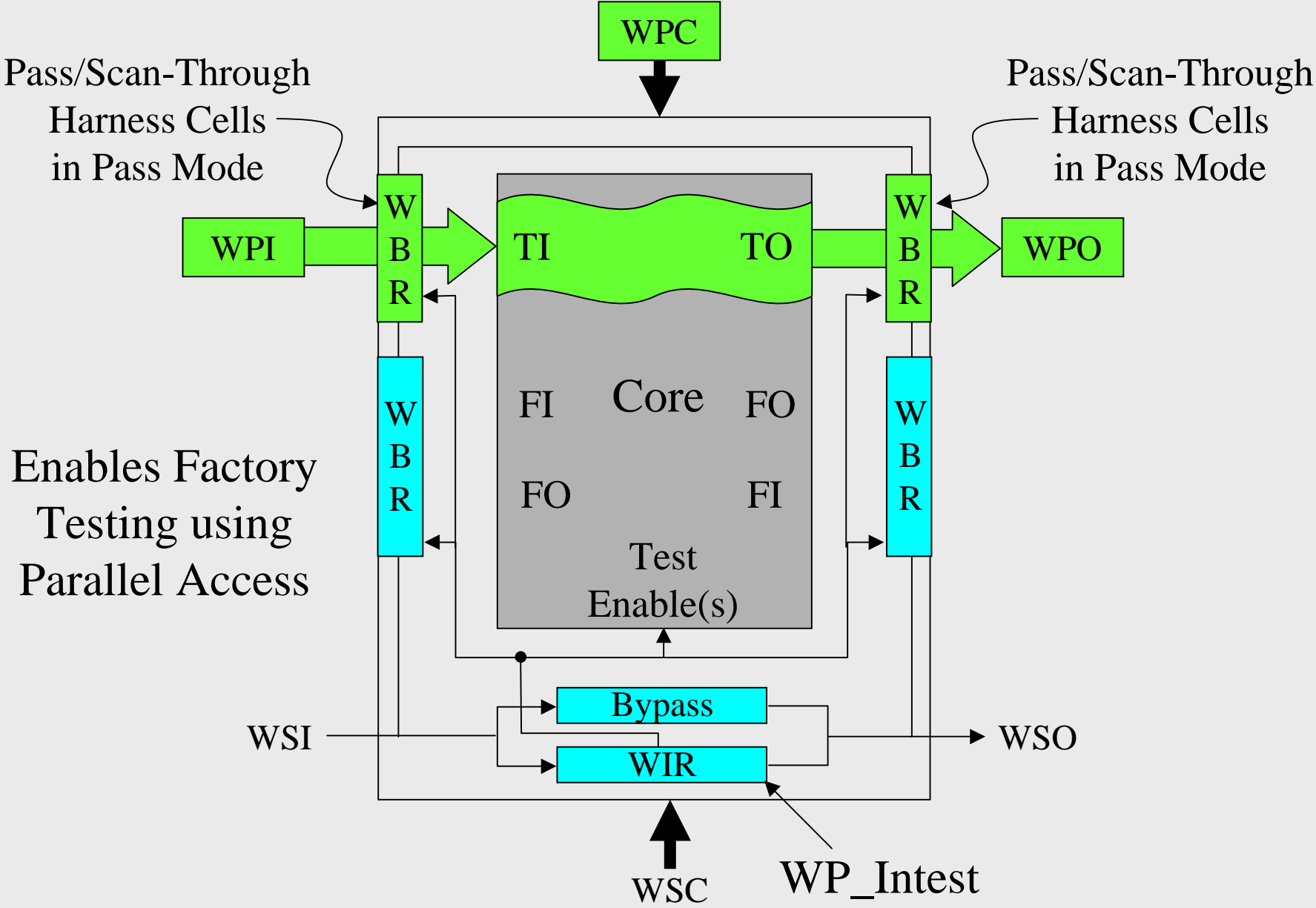

# Example of Pass/Scan Through Cells in Scan Mode

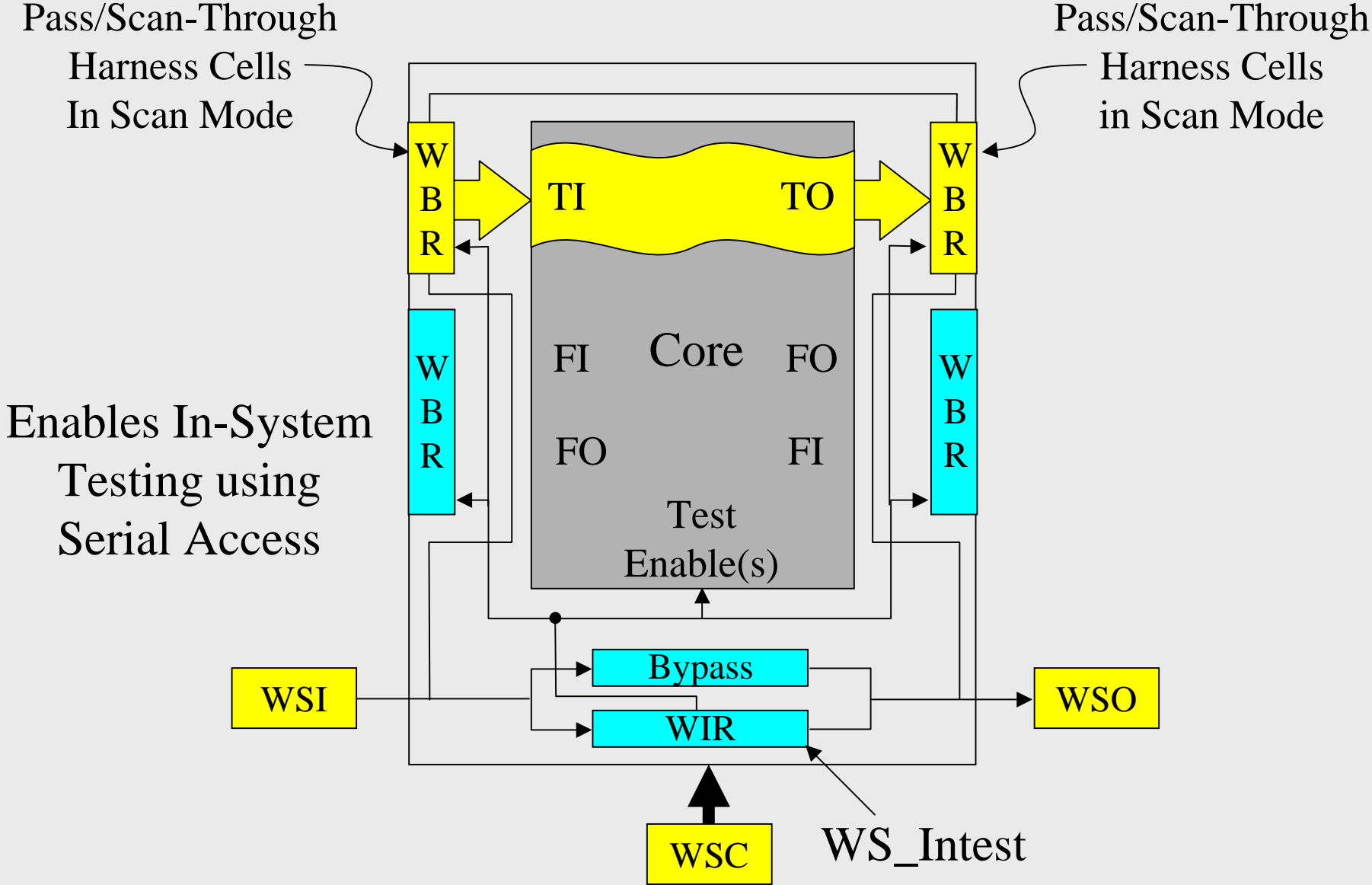

# Summary

- A Standard Core Wrapper has been presented
- Its Architecture is Simple and Extendable
- Its Serial Port is Plug&Play for Standardized Testing
- Its Parallel Port is User Defined for Test Flexibility
- Its Instruction Set is Well Defined and Expandable
- A Draft is in preparation for Ballot in early 2003