

# **Update of IEEE P1500 Core Wrapper Architecture**

Presented by  
Erik Jan Marinissen  
on behalf of CTAG Working Group

IEEE VLSI Test Symposium (VTS'03)  
Napa, CA – April 27, 2003

# Topics

- Wrapper Overview & Applications
- Wrapper Architecture & Instructions
- Wrapper Harness Cells
- Summary

# Block Level Overview of a P1500 Wrapper

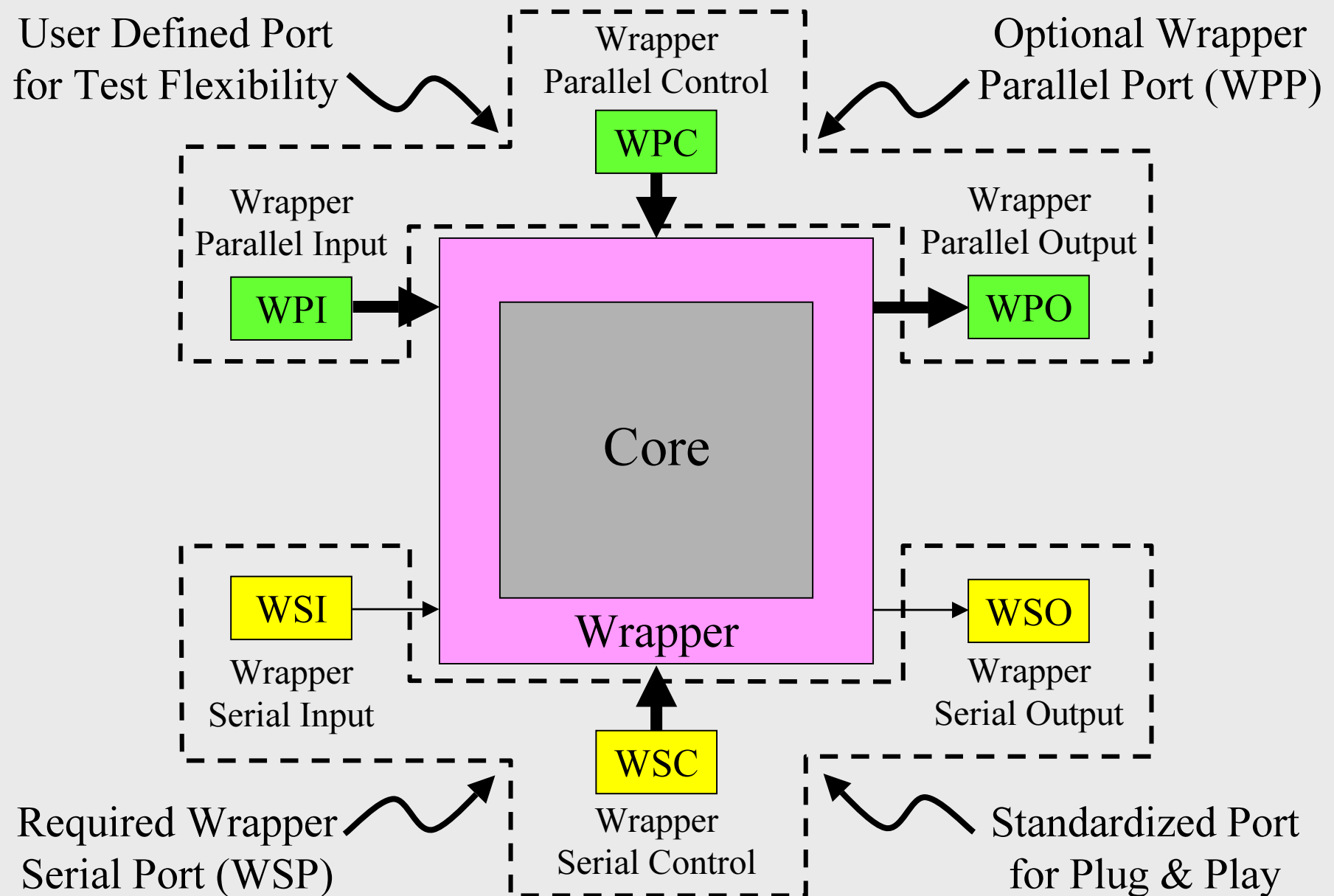

# P1500 Wrapper Configuration Examples

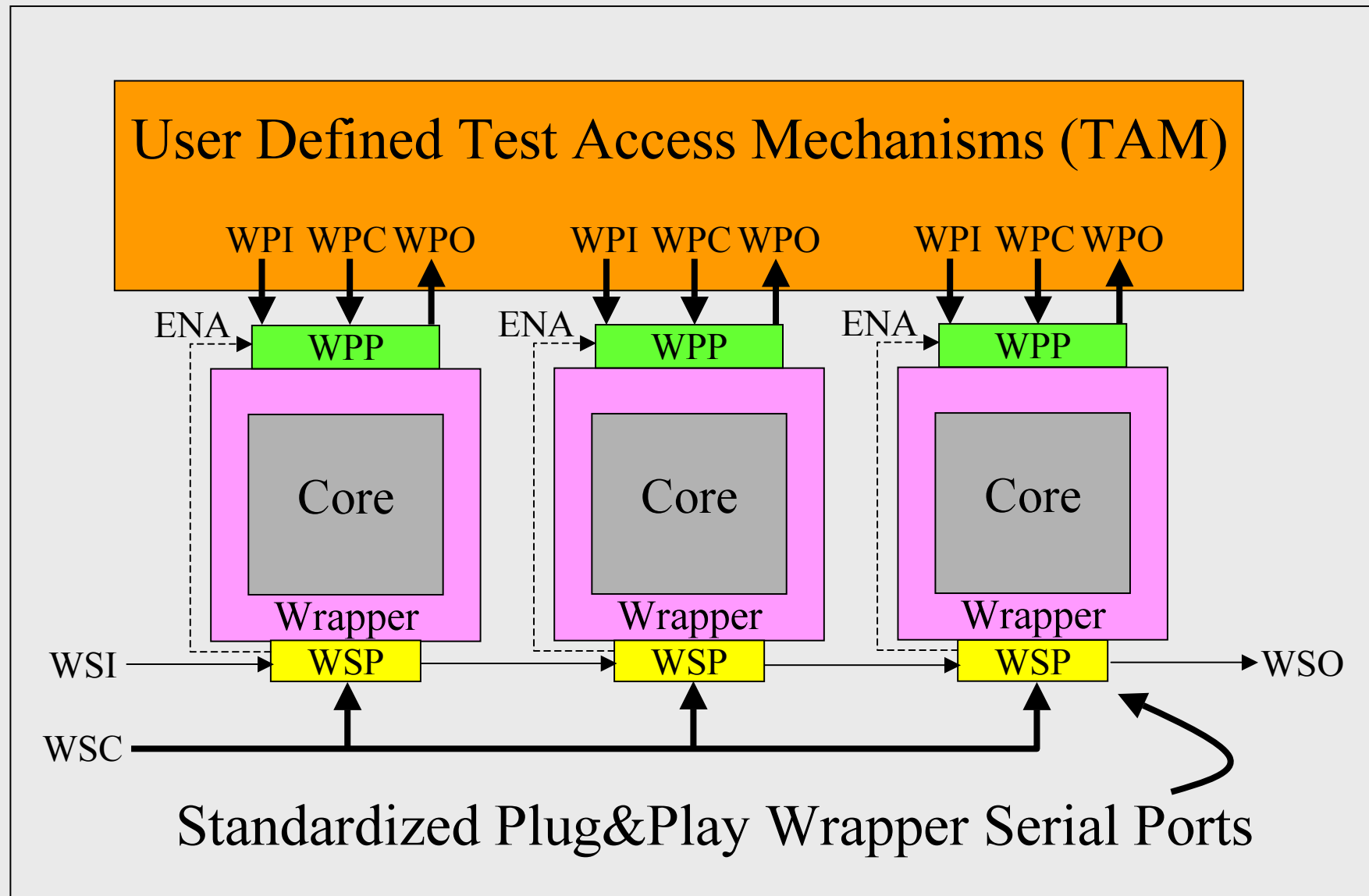



# P1500 Wrapper Configuration Examples

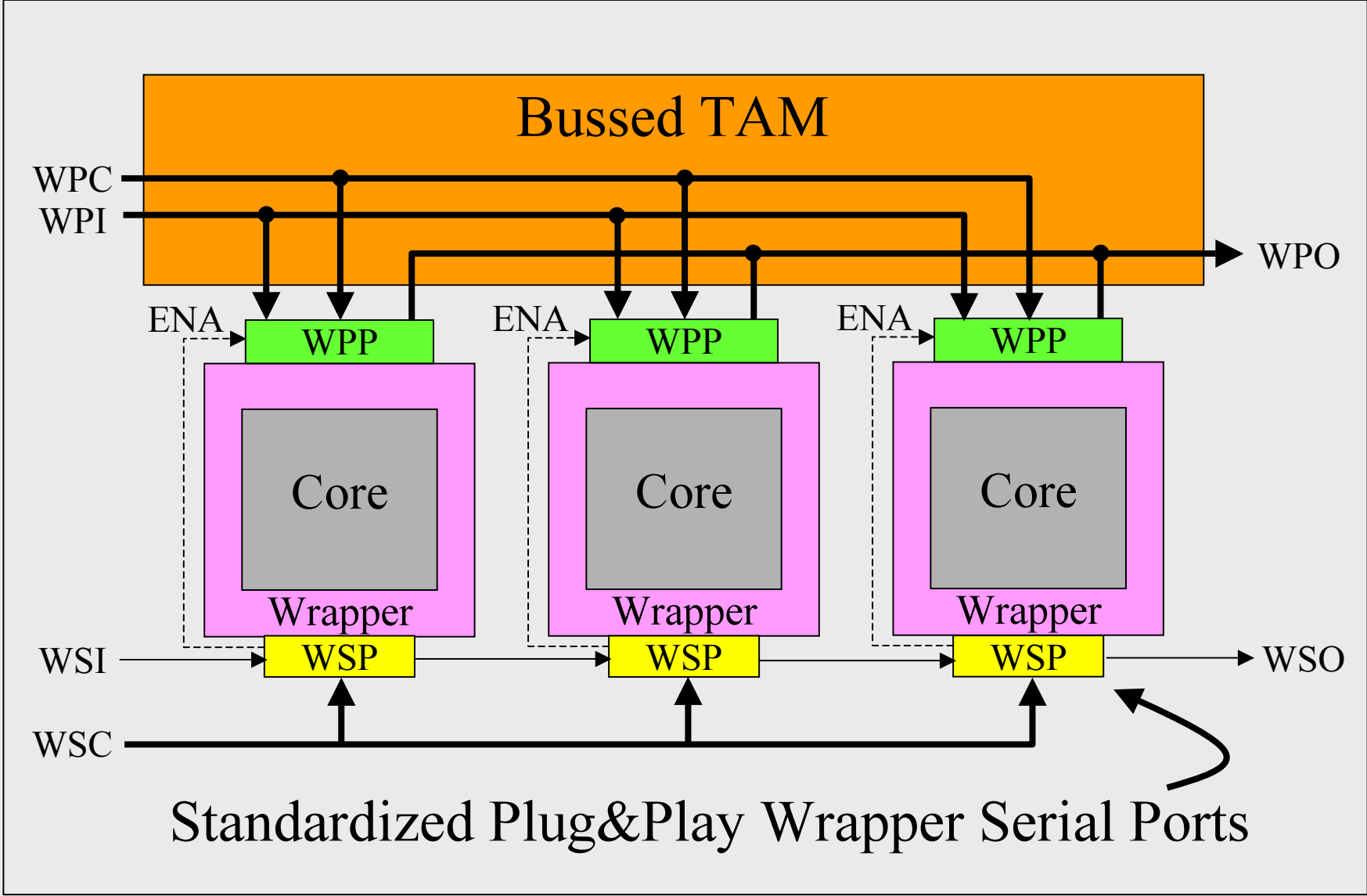

# P1500 Wrapper Configuration Examples

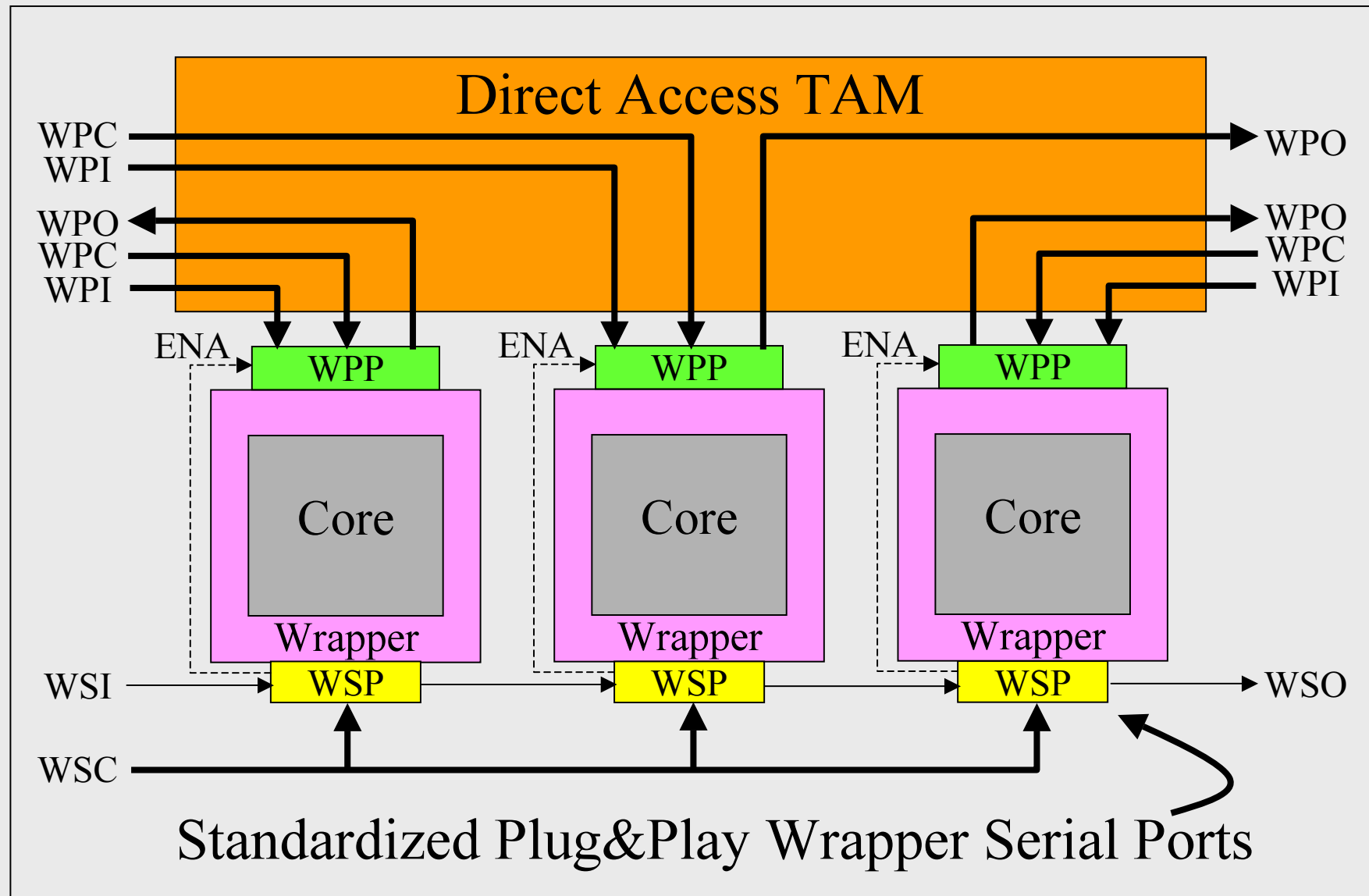

# P1500 Wrapper Configuration Examples

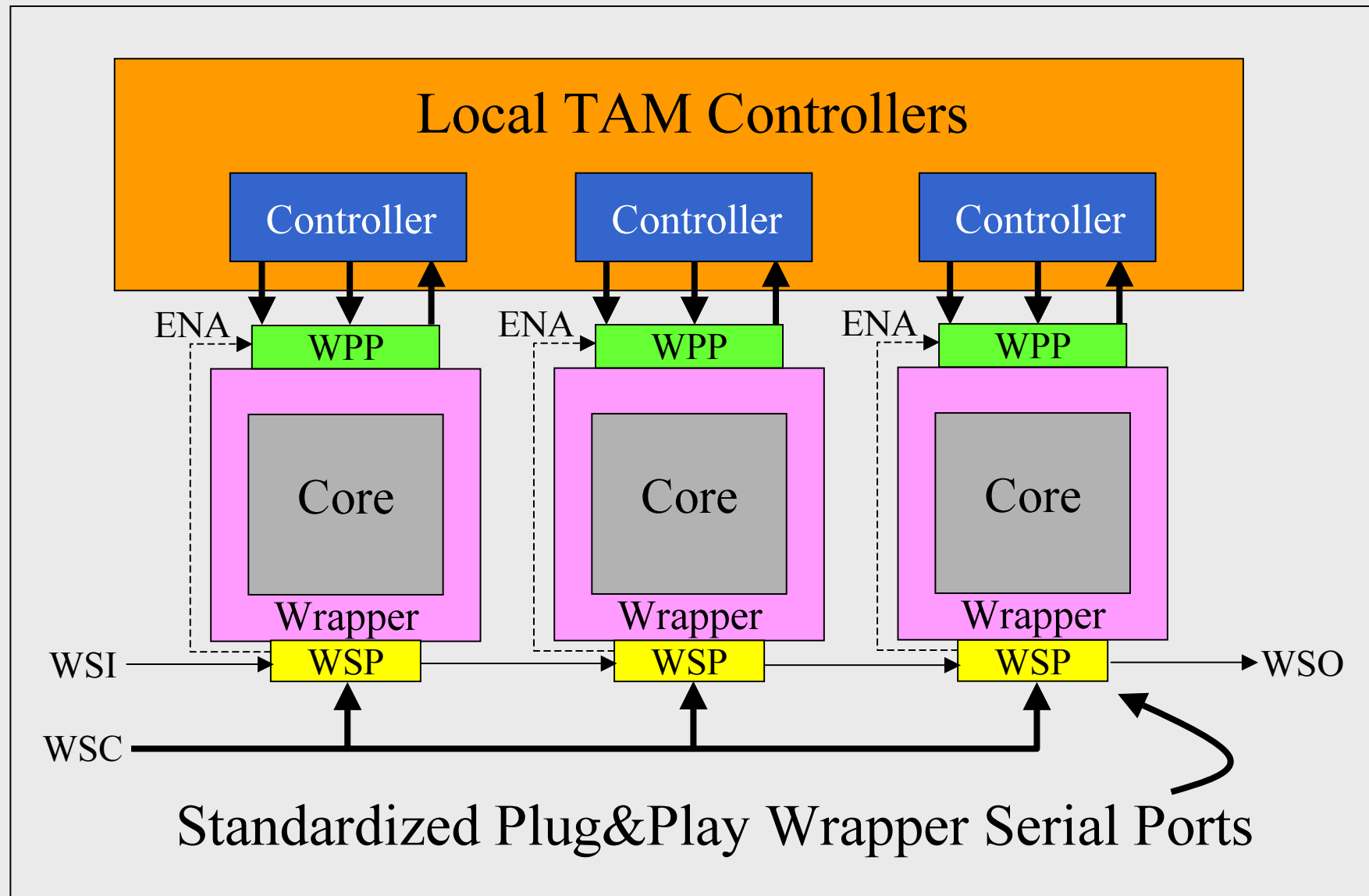

# Wrapper Architecture & Instructions

# View of the Required P1500 Wrapper Architecture

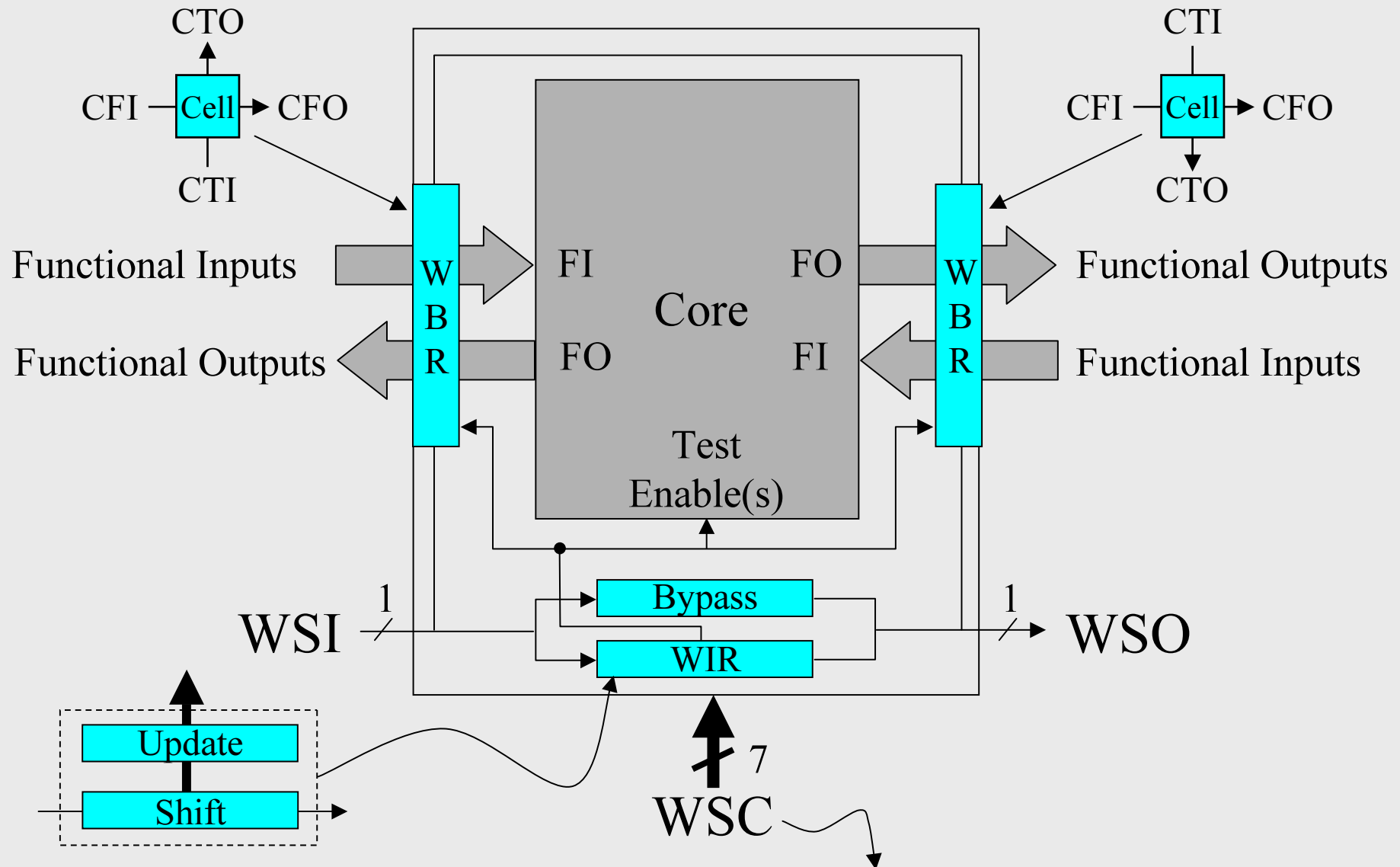

(WRST, WCLK, SelectWR, Capture, Shift, Update, Transfer)

# P1500 Wrapper Test Instructions

<b>WS_BYPASS</b>	- <b>Required</b>	
WS_PRELOAD	- Optional	
WP_PRELOAD	- Optional	
WS_CLAMP	- Optional	
WS_SAFE	- Optional	
WS_INTEST_RING	- Optional	<b>At Least One Optional INTEST is Required</b>
WS_INTEST_SCAN	- Optional	
* WP_INTEST_RING	- Optional	
* WP_INTEST_SCAN	- Optional	
WH_INTEST	- Optional	
<b>WS_EXTEST</b>	- <b>Required</b>	
WP_EXTEST	- Optional	
WH_EXTEST	- Optional	

\* Example of an optional user-defined instruction

# P1500 Wrapper Test Instructions

Instruction	Controlling Port
WS_BYPASS	WSP
WS_PRELOAD	WSP
WP_PRELOAD	WPP
WS_CLAMP	WSP
WS_SAFE	WSP
WS_INTEST_RING	WSP
WS_INTEST_SCAN	WSP
* WP_INTEST_RING	WPP
* WP_INTEST_SCAN	WPP
WH_INTEST	WSP and/or WPP
WS_EXTEST	WSP
WP_EXTEST	WSP or WPP
WH_EXTEST	WSP and/or WPP

# Instruction Field Naming Conventions

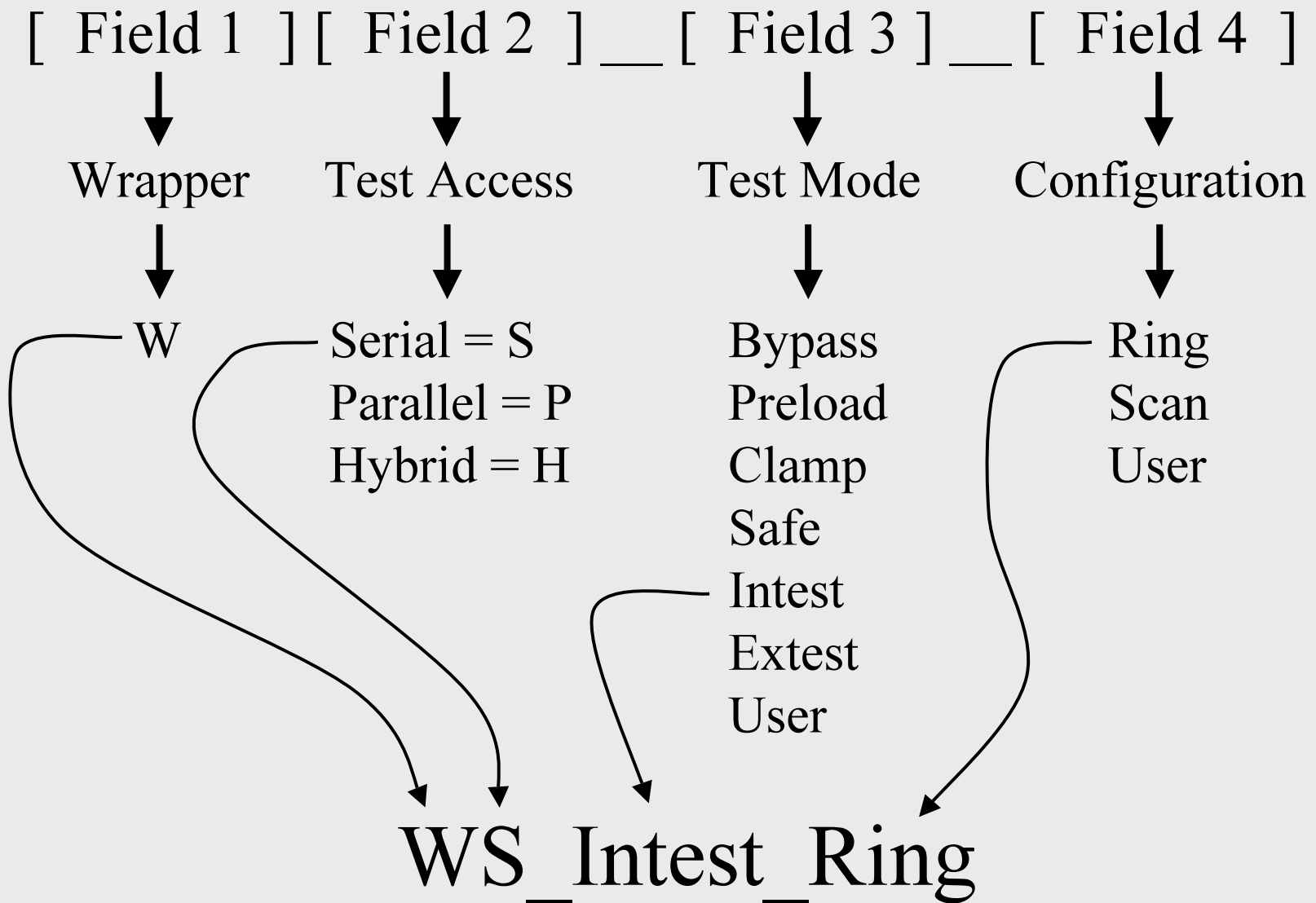

# Wrapper Serial Bypass (WS\_Bypass) Instruction

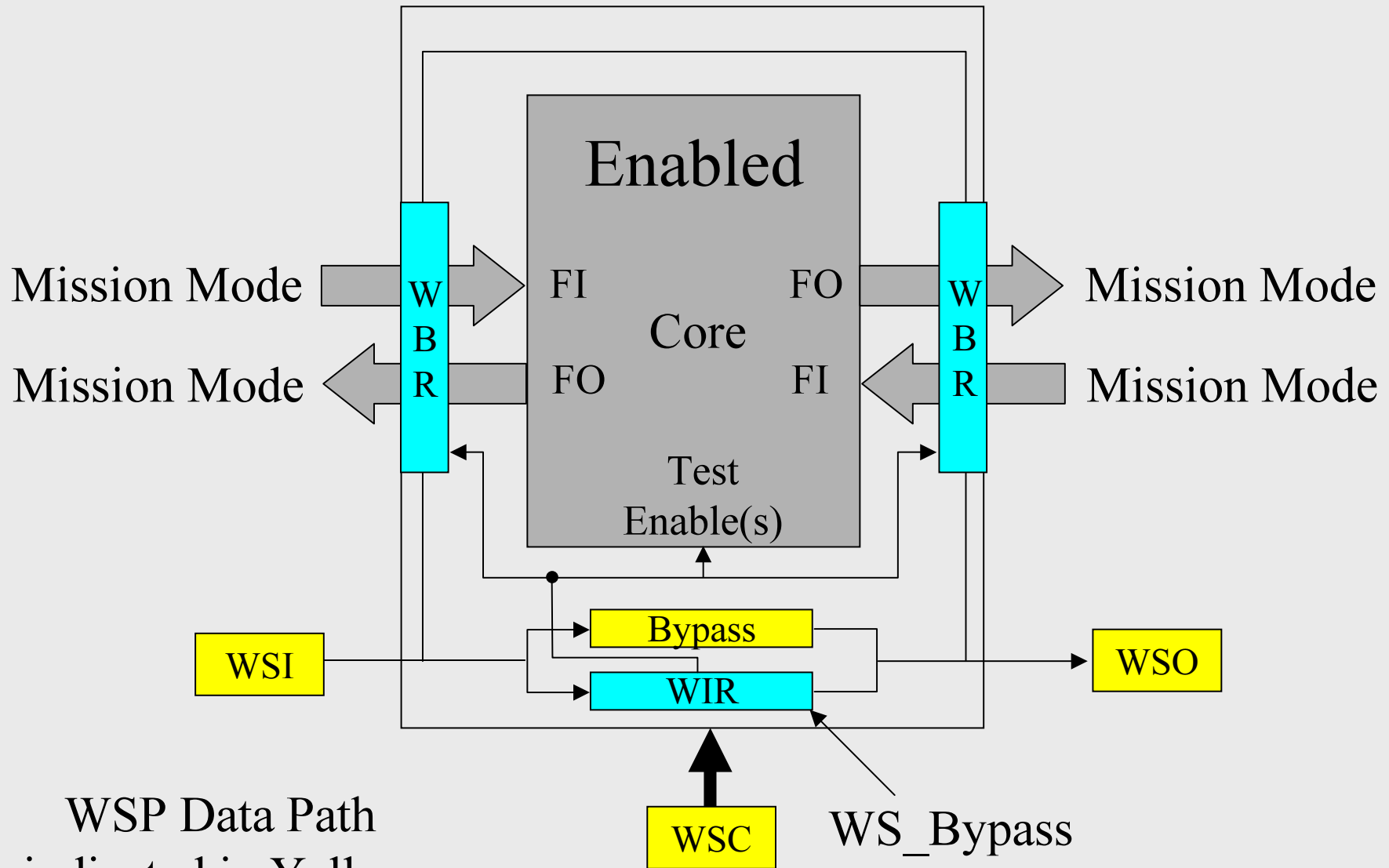

# Wrapper Serial Preload (WS\_Preload) Instruction

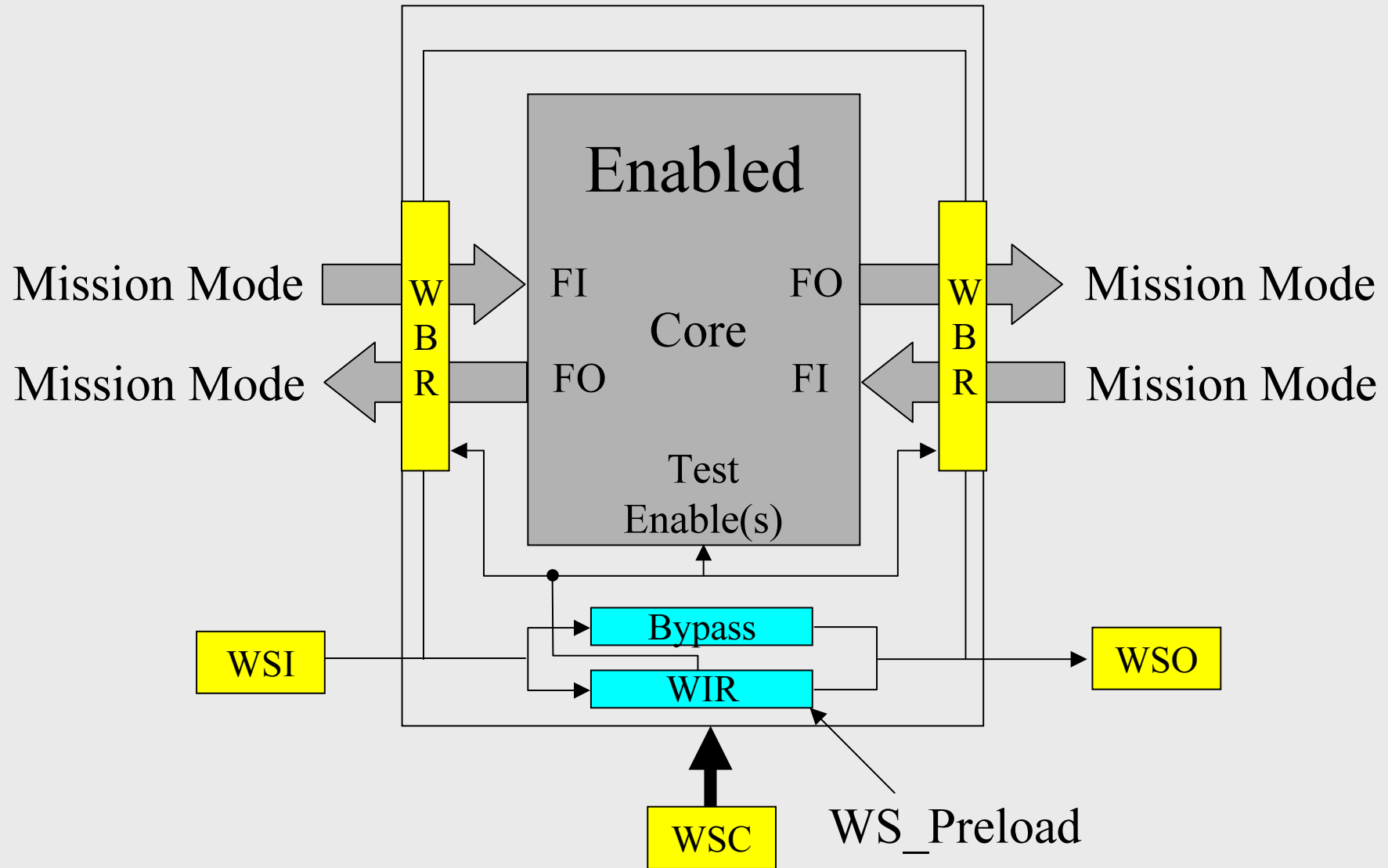

# Wrapper Parallel Preload (WP\_Preload) Instruction

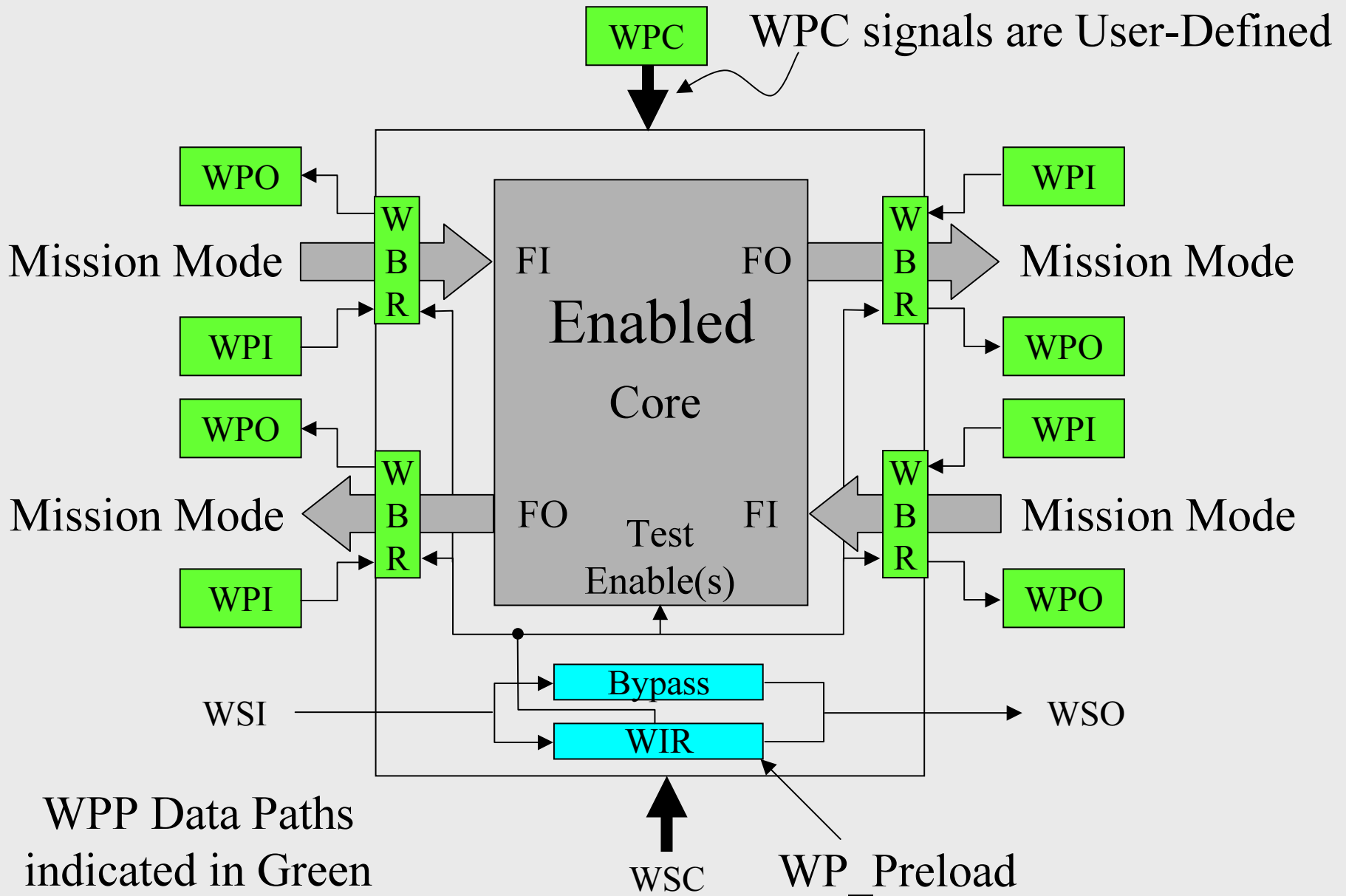

# Wrapper Serial Clamp (WS\_Clamp) Instruction

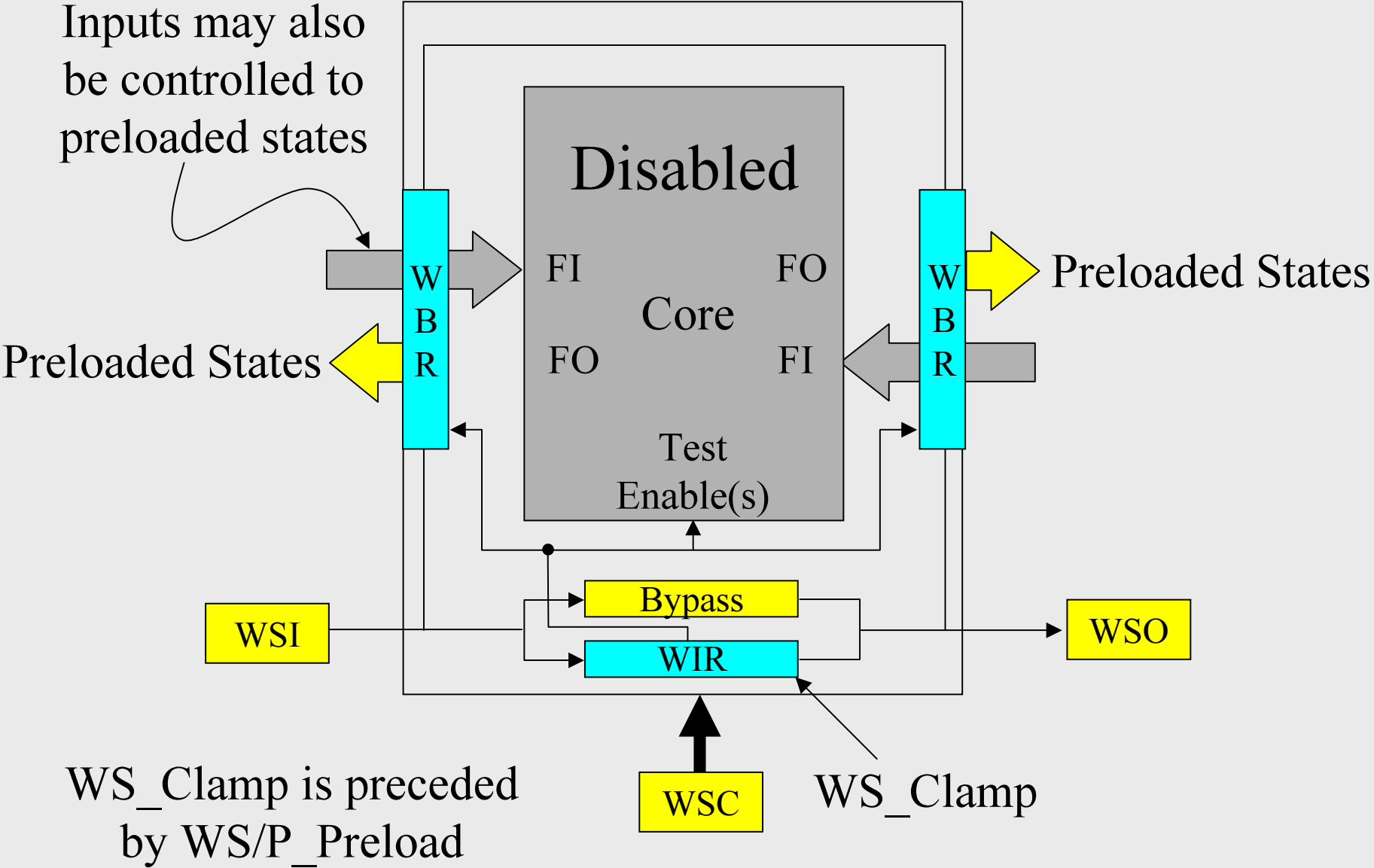

# Wrapper Serial Safe (WS\_Safe) Instruction

Inputs may also be controlled to safe states

Forced Safe States

Forced Safe States

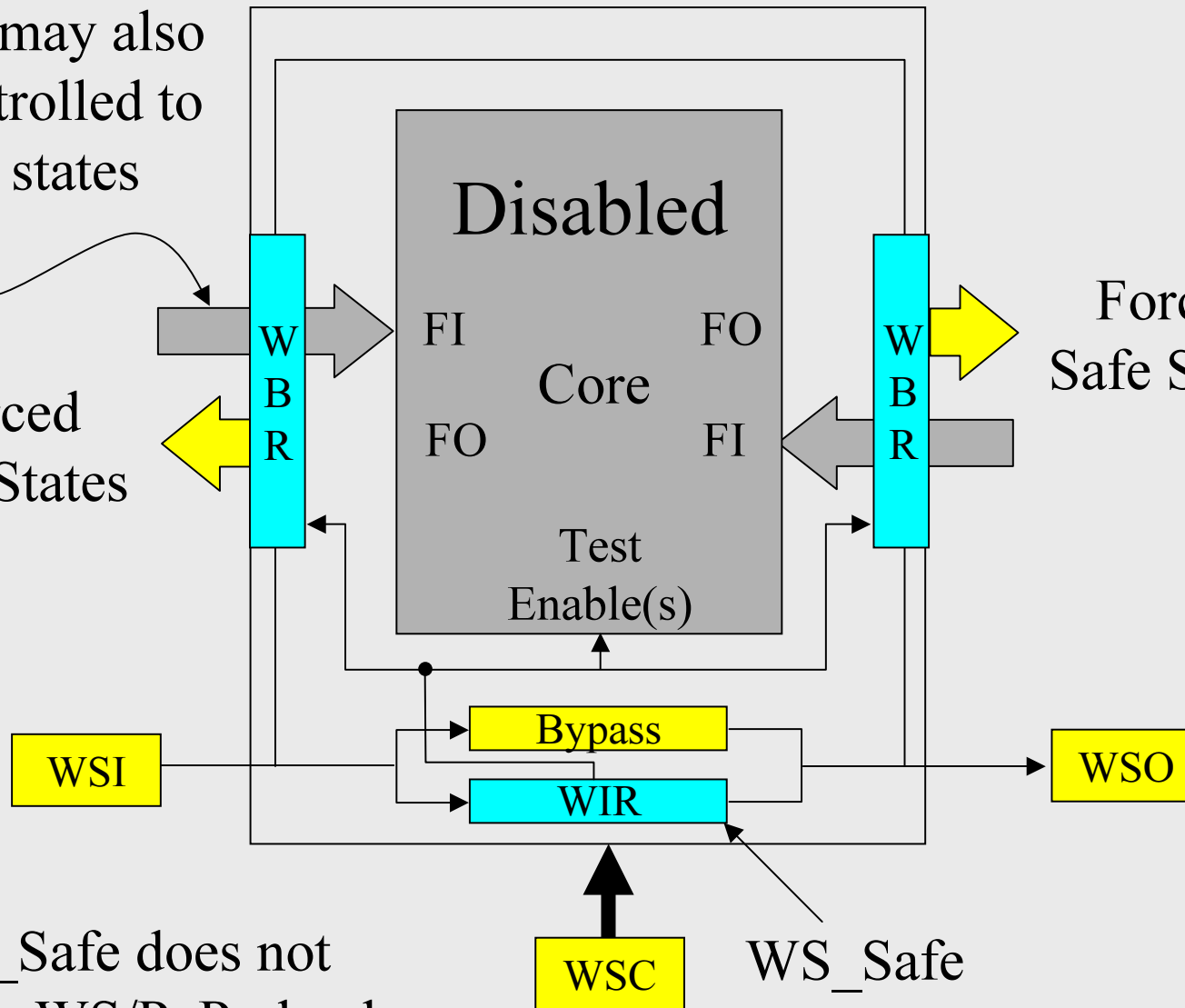

WS\_Safe does not require WS/P\_Preload



# Wrapper Serial Intest Scan (WS\_Intest\_Scan) Mode

Test is applied  
via WSC Controlled  
WBR & Internal  
Scan Path

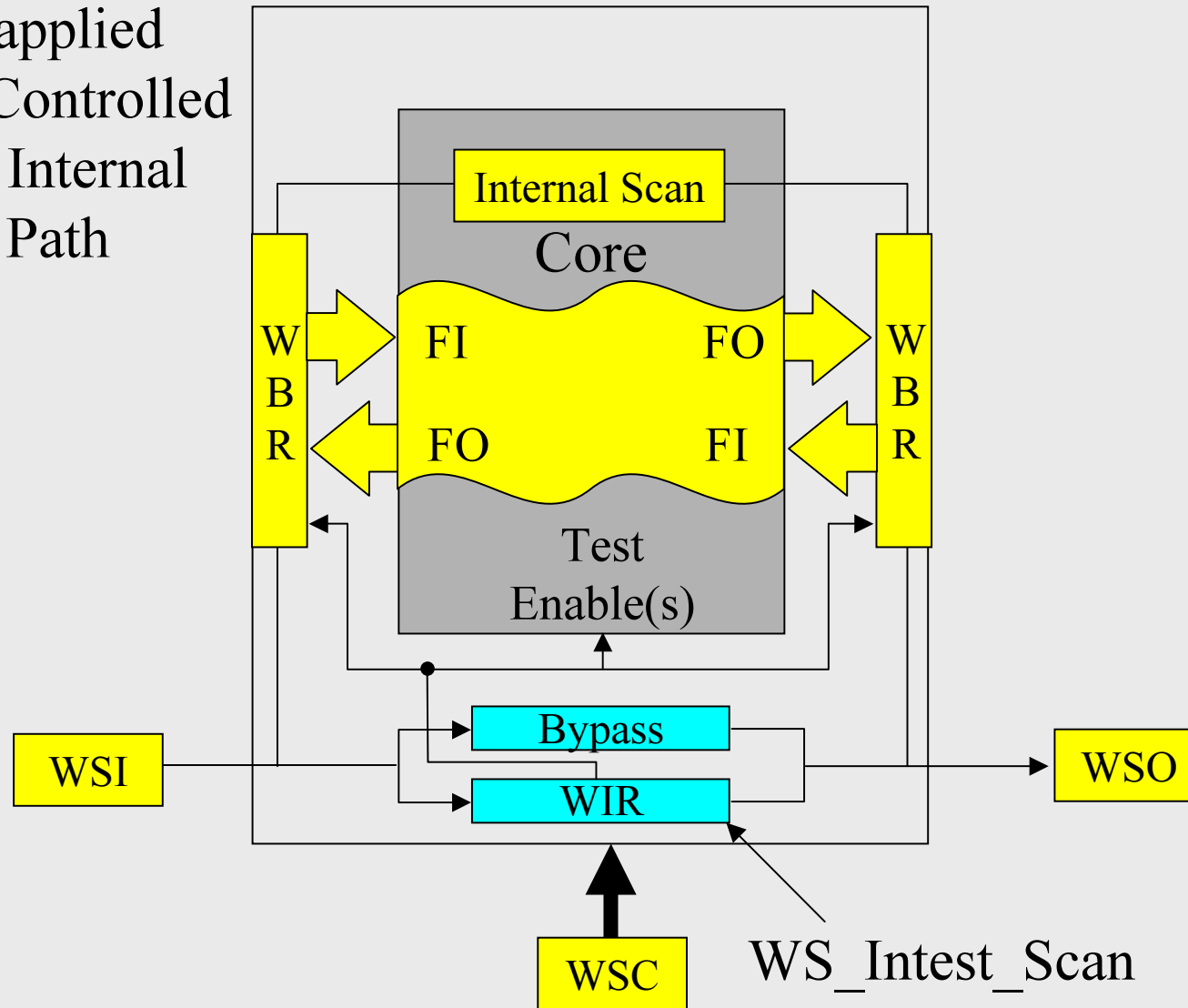

# Wrapper Parallel Intest Ring (WP\_Intest\_Ring) Mode

Test is applied  
via WPC Controlled  
WBR Segments

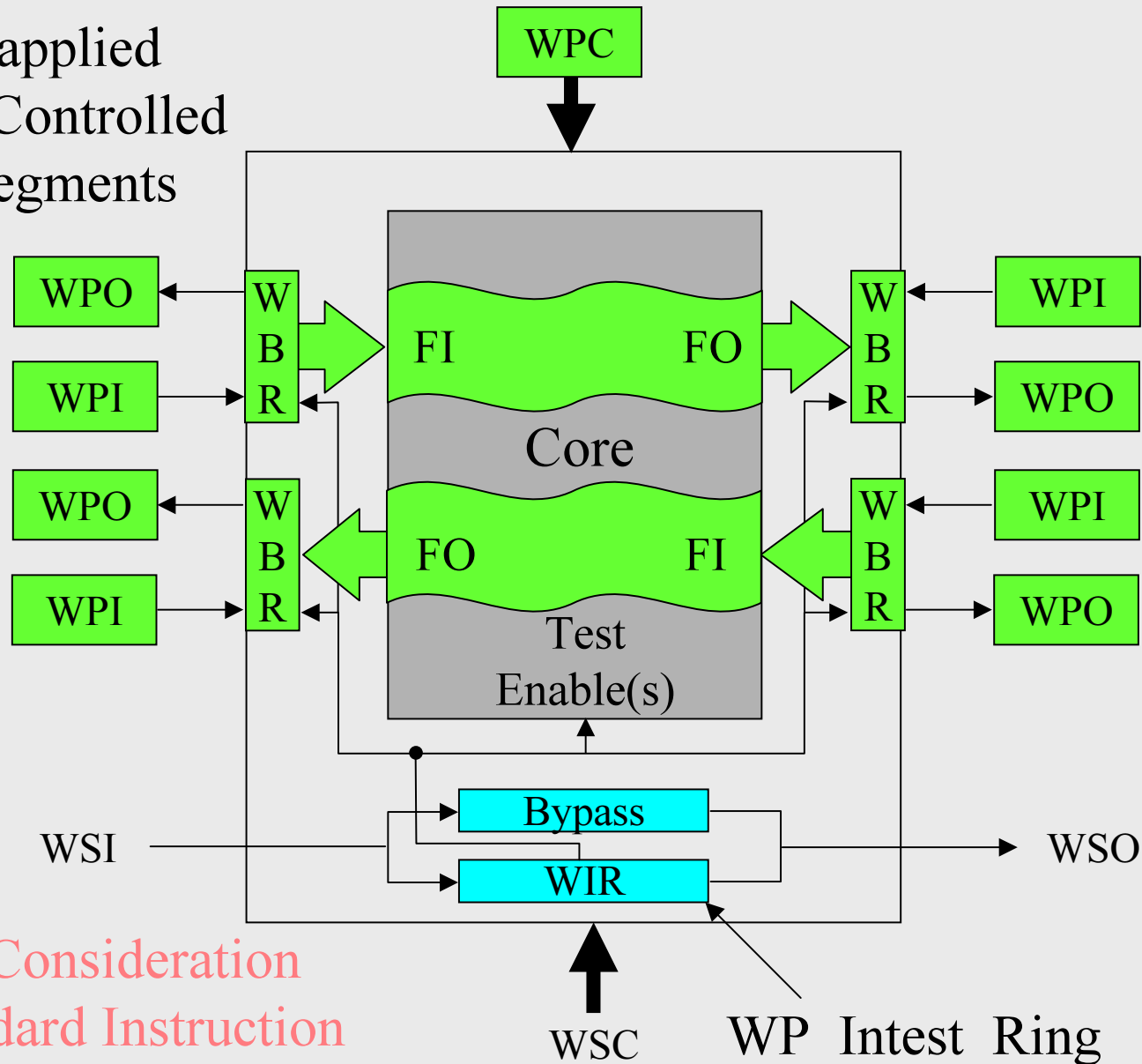

# Wrapper Parallel Intest Scan (WP\_Intest\_Scan) Mode

Test is applied  
via WPC Controlled  
WBR & Internal  
Scan Segments

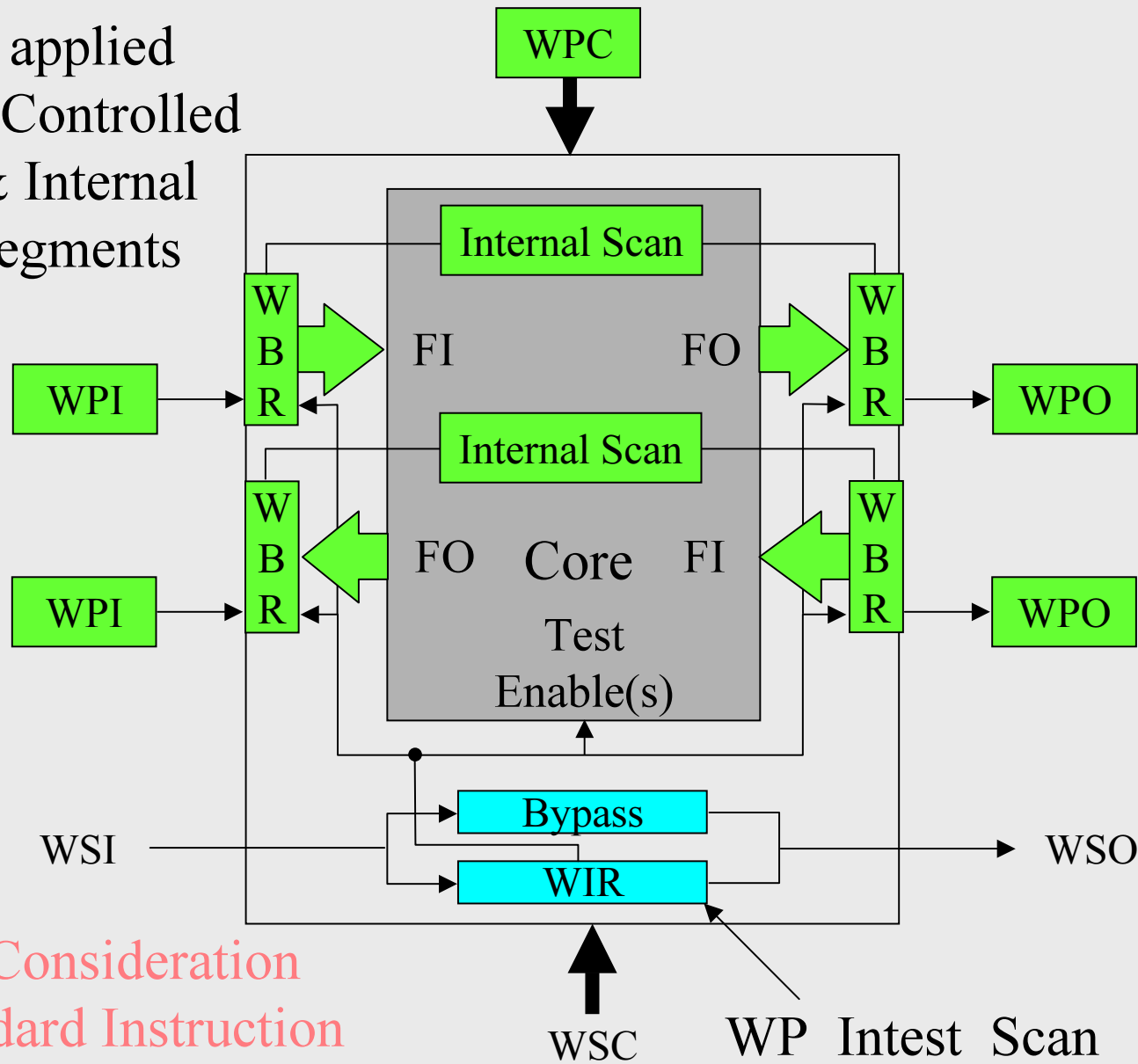

Under Consideration  
as a Standard Instruction

# Wrapper Hybrid Intest (WH\_Intest) Mode

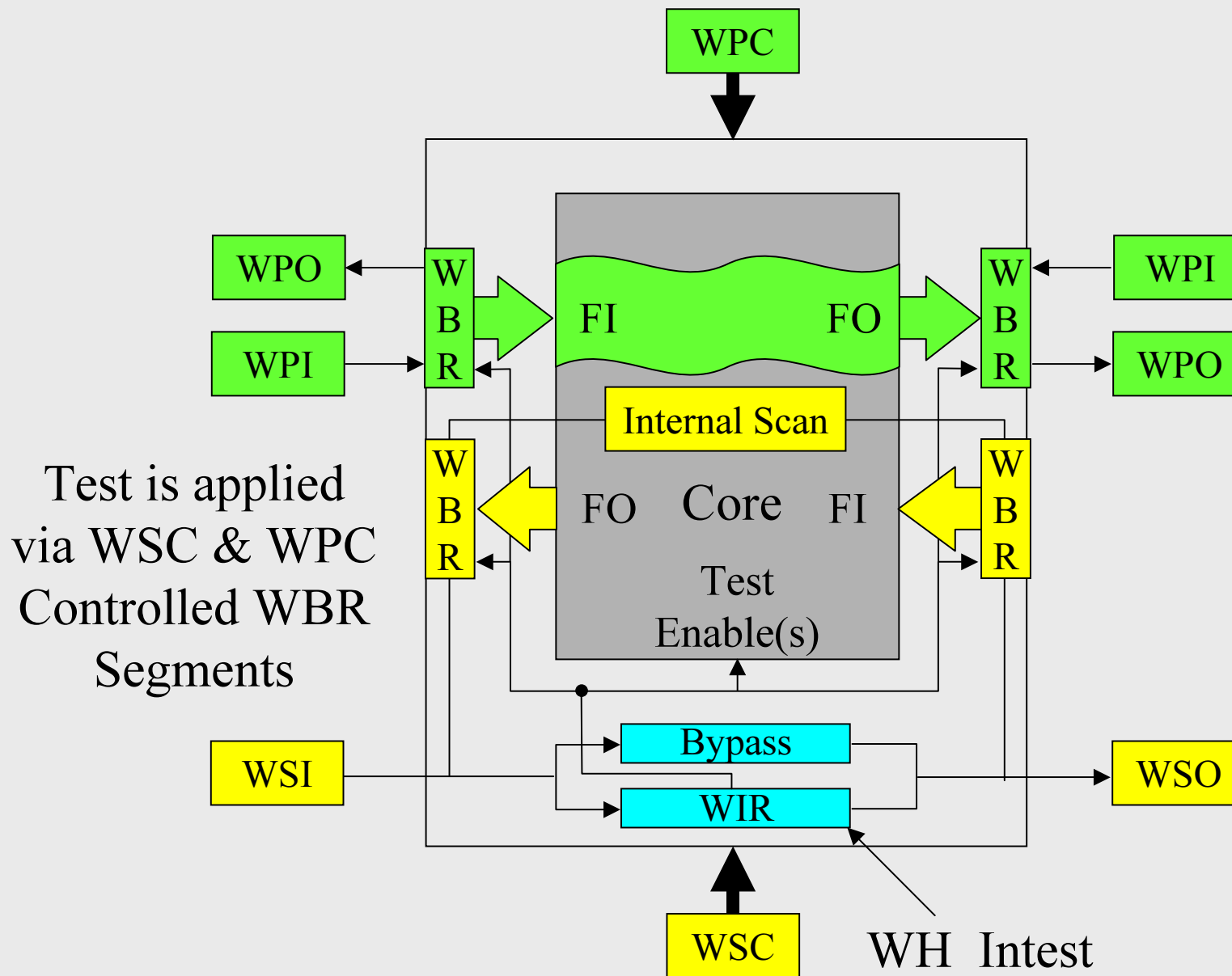

# Wrapper Serial Exttest (WS\_Exttest) Mode

Test is applied  
via WSC Controlled  
WBR Scan Path

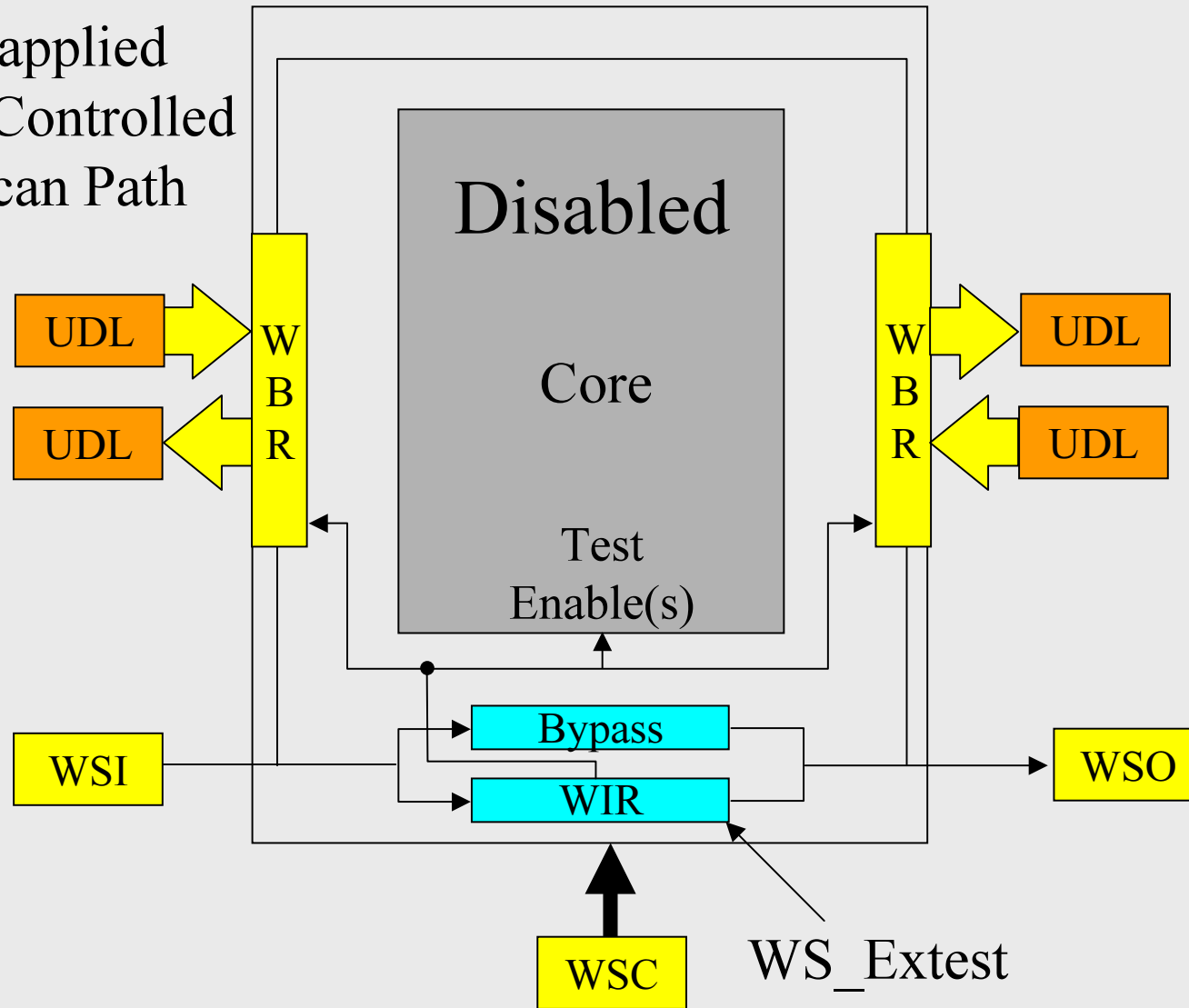

# Wrapper Parallel Extest (WP\_Extest) Mode

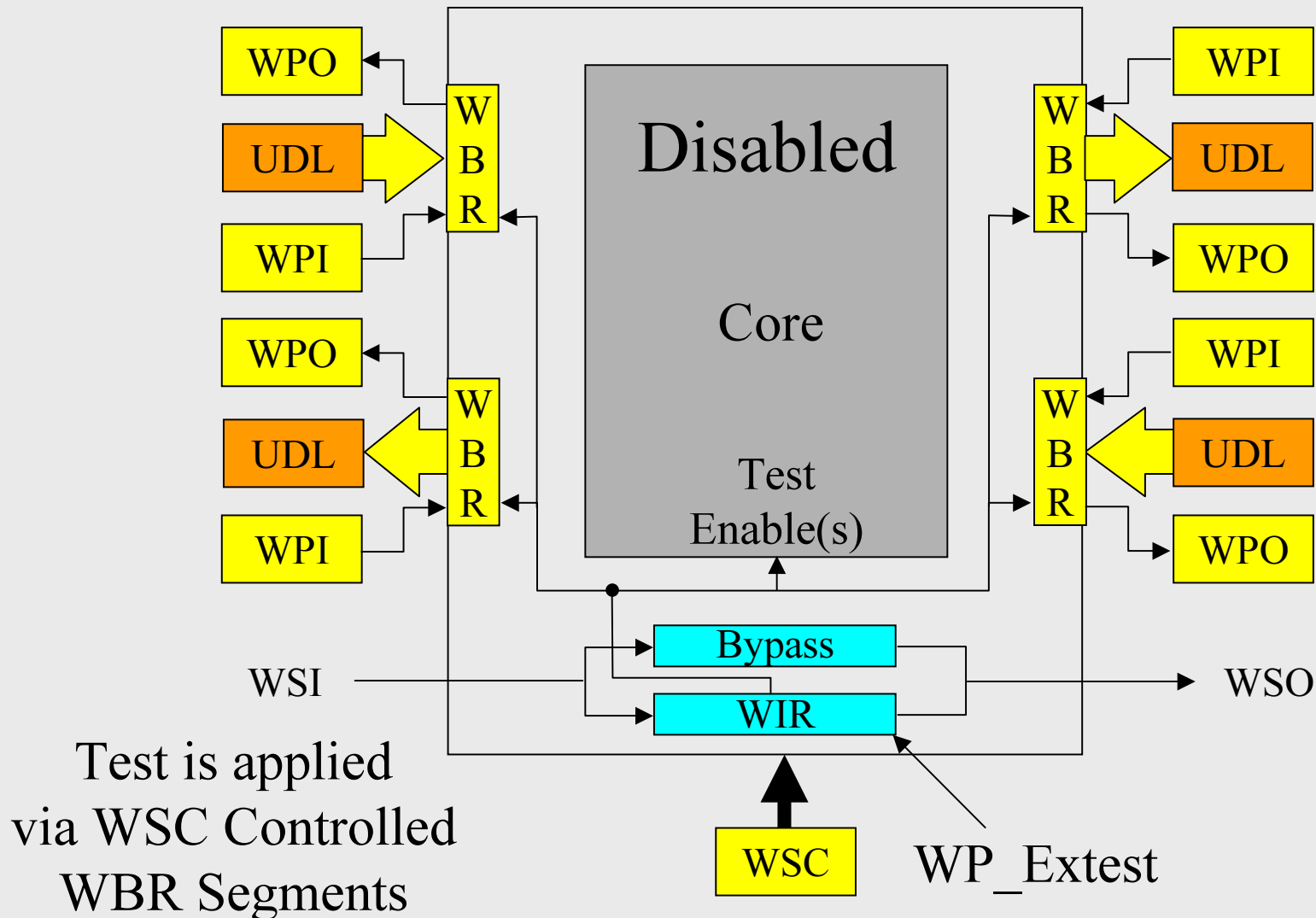

# Wrapper Parallel Extest (WP\_Extest) Mode

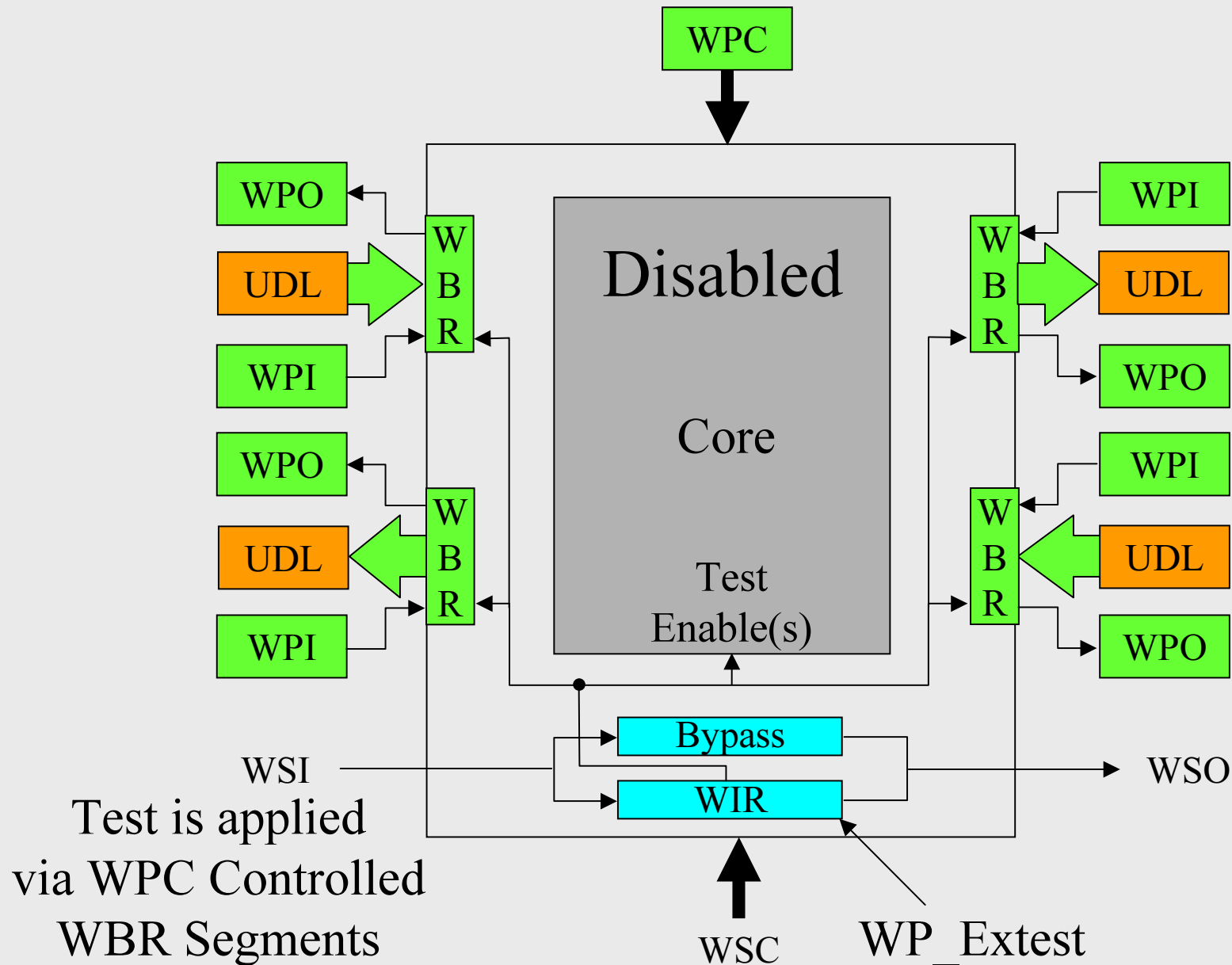

# Wrapper Hybrid Extest (WH\_Extest) Mode

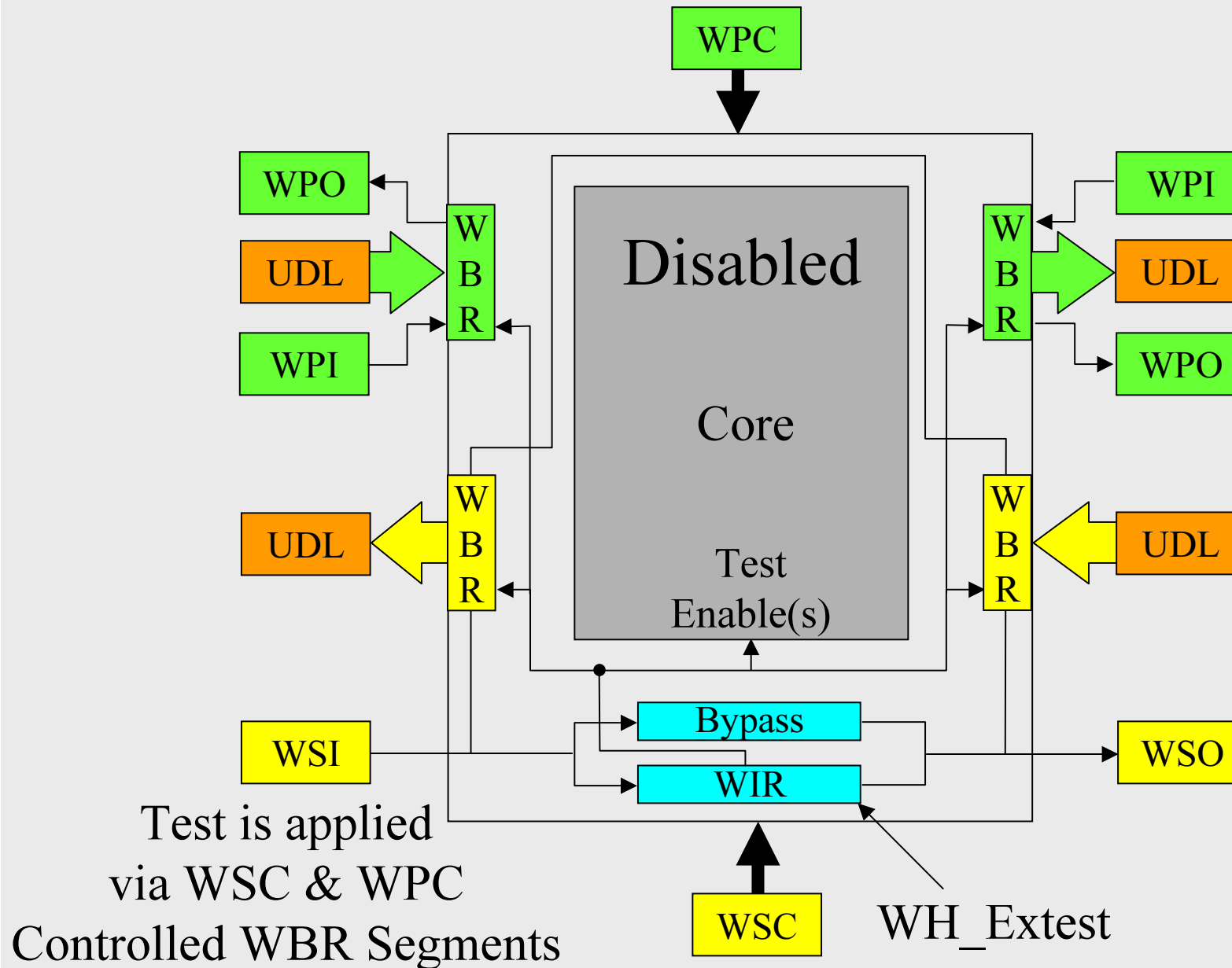

# Wrapper Harness Cells

# Applying Wrappers to Test Only Inputs & Outputs

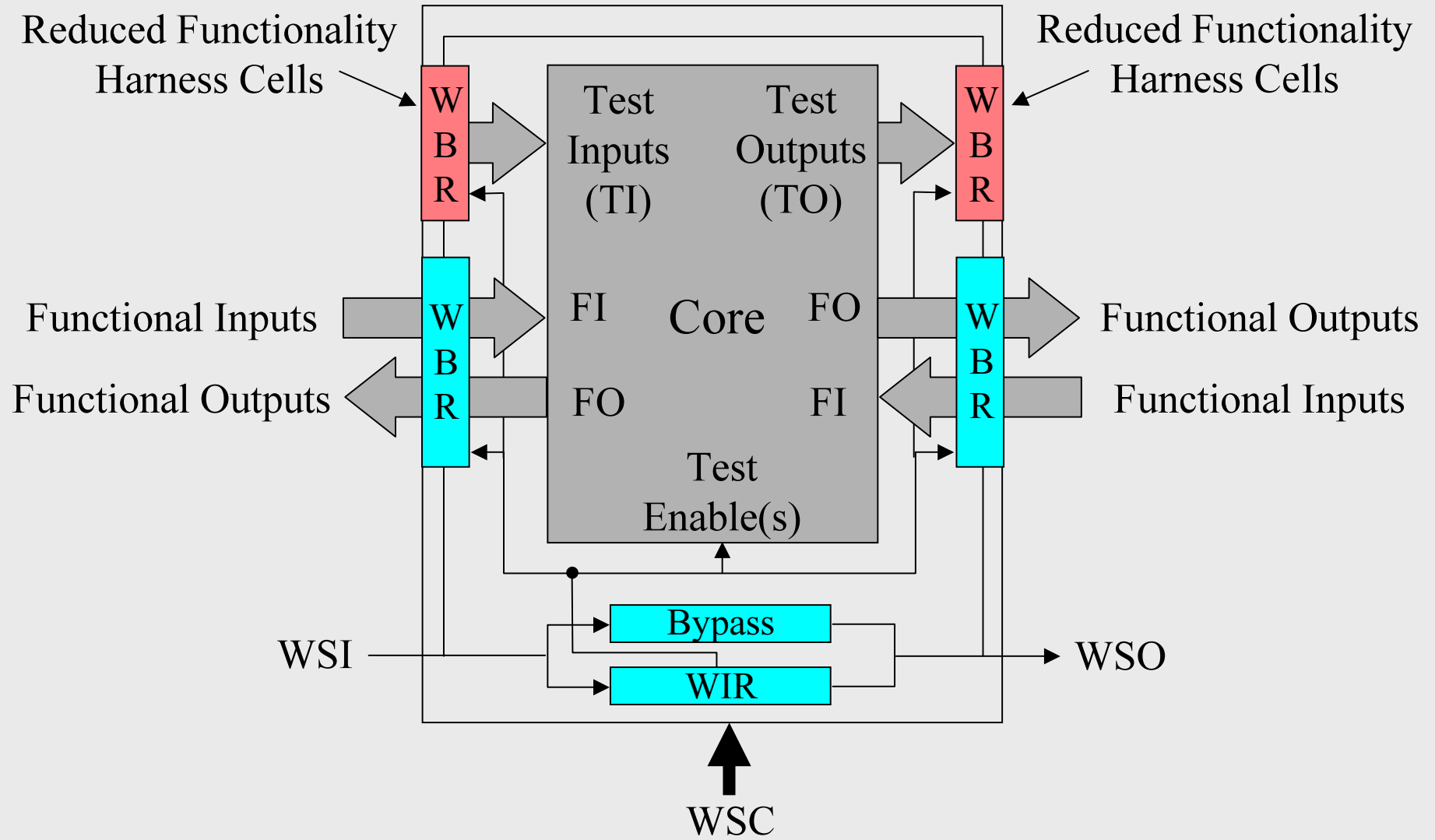

# Pass-Through Harness Cells

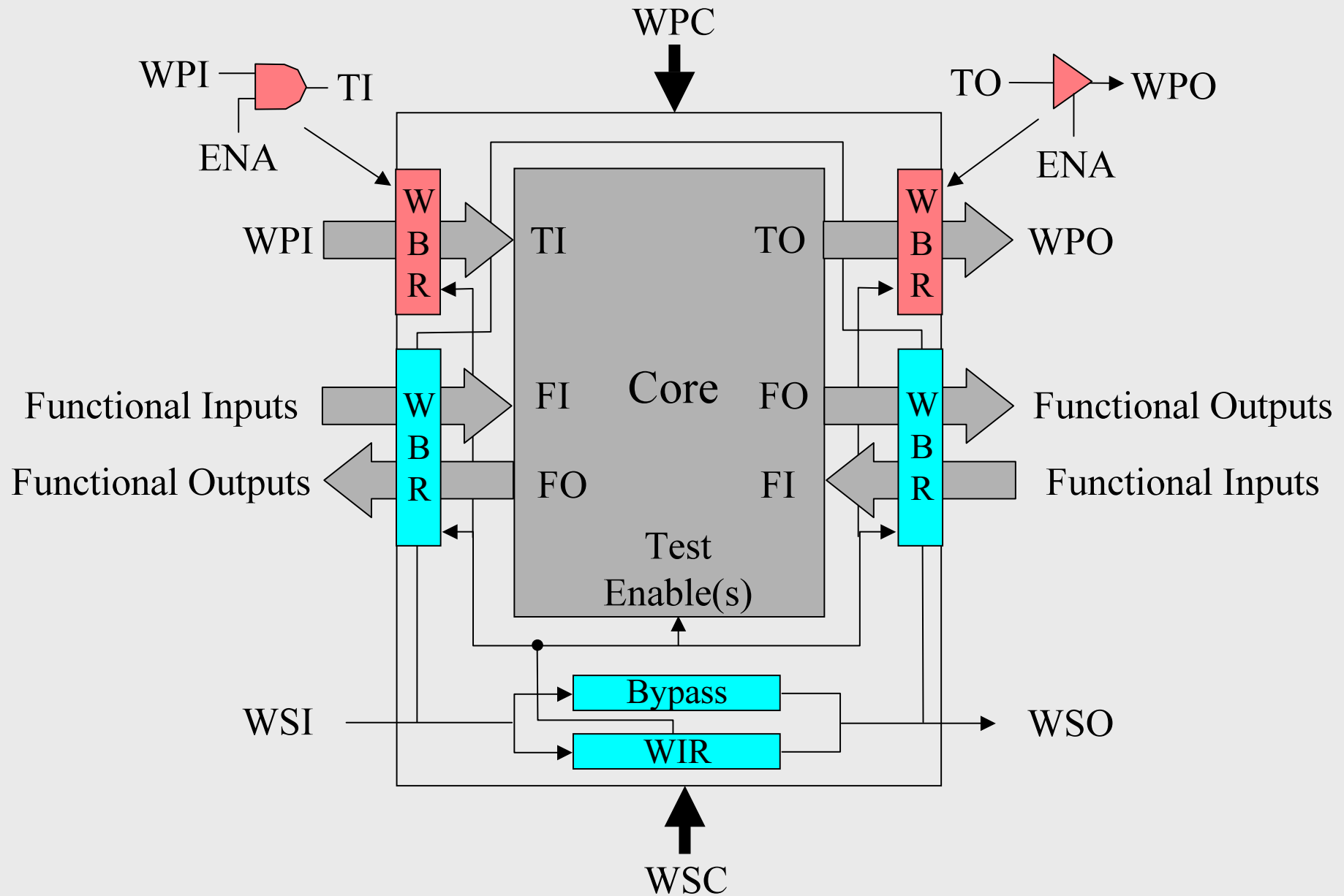

# Scan-Through Harness Cells

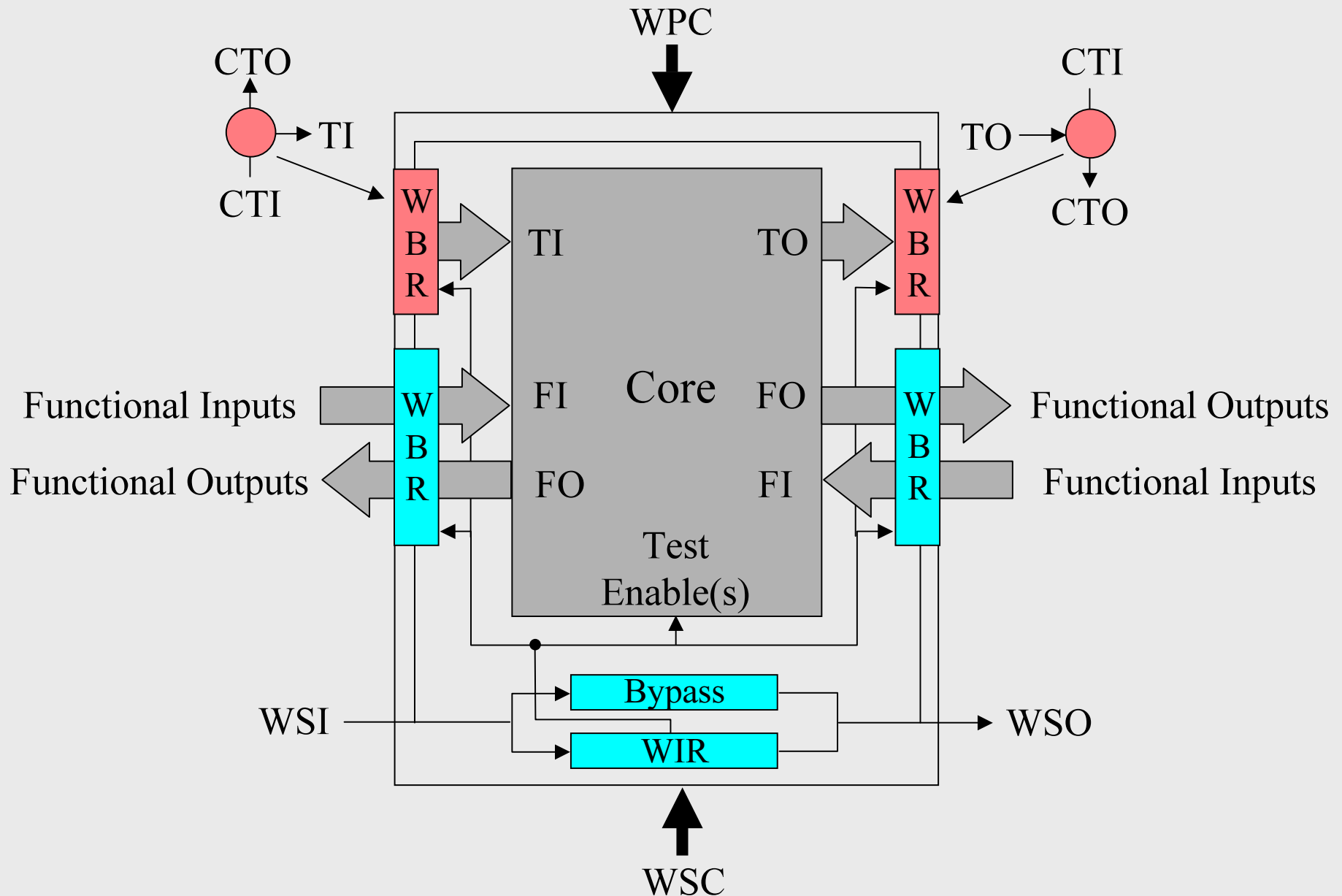

# Pass/Scan-Through Harness Cells

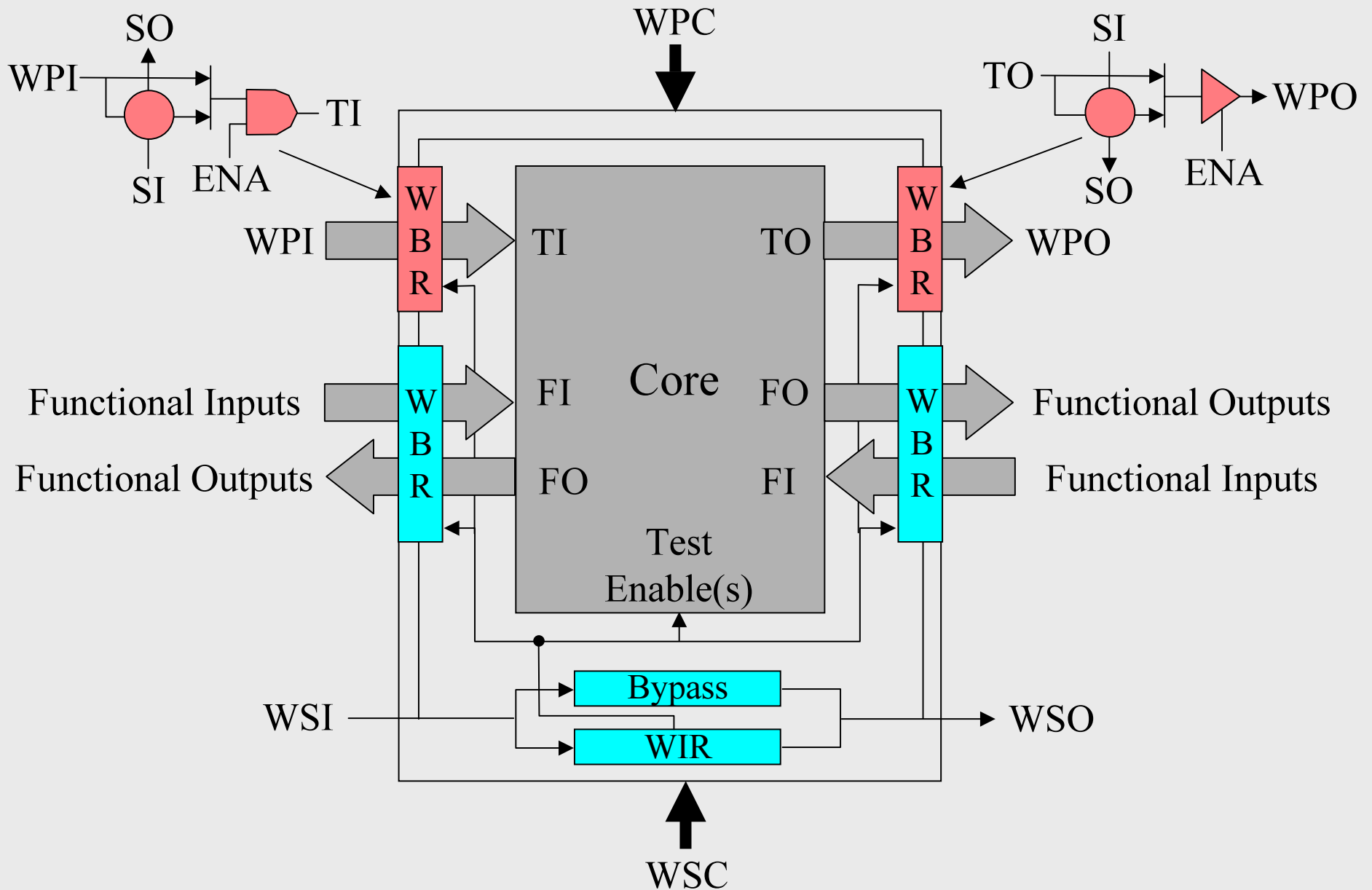





# Example of Pass/Scan Through Cells in Pass Mode

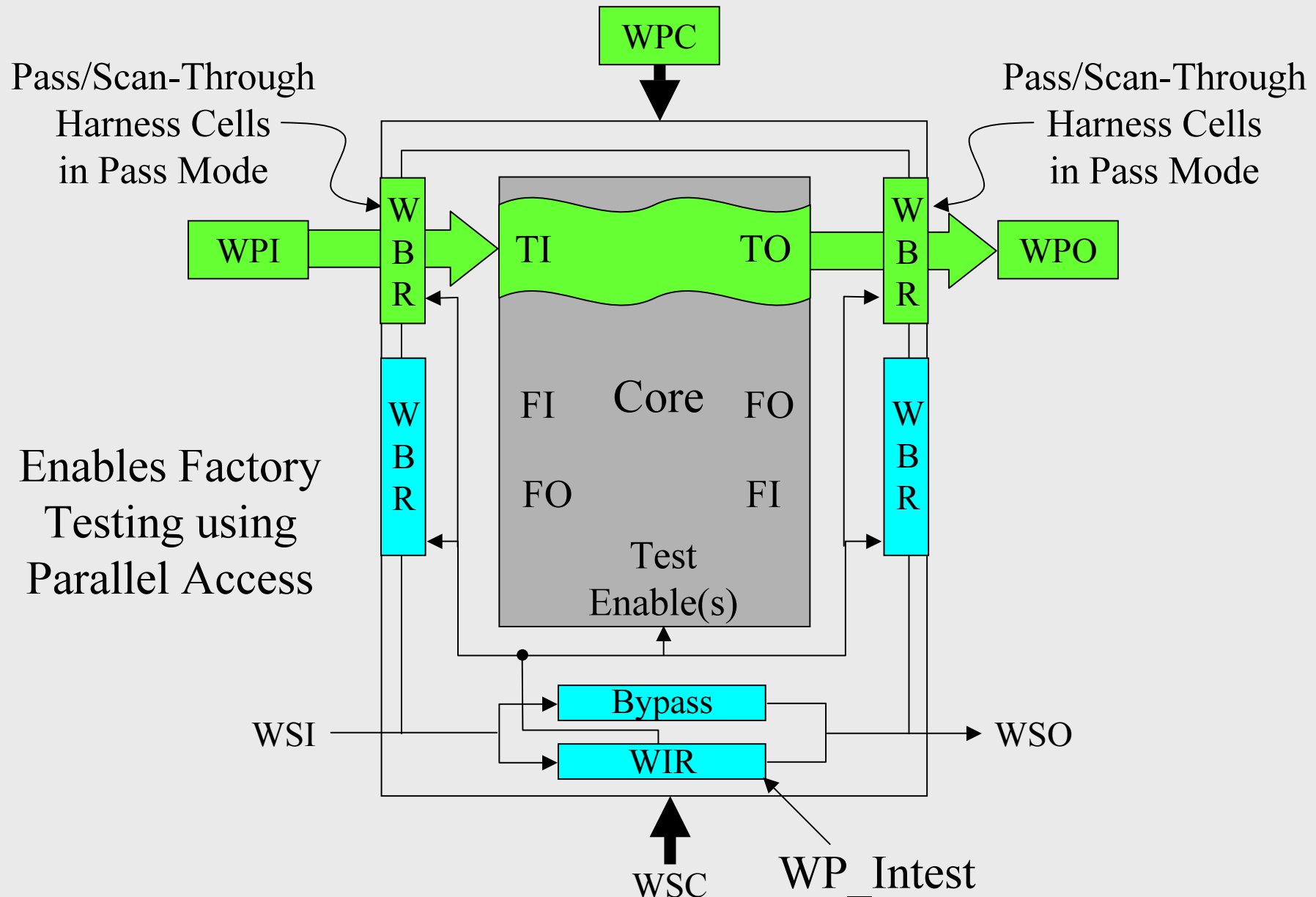

# Example of Pass/Scan Through Cells in Scan Mode

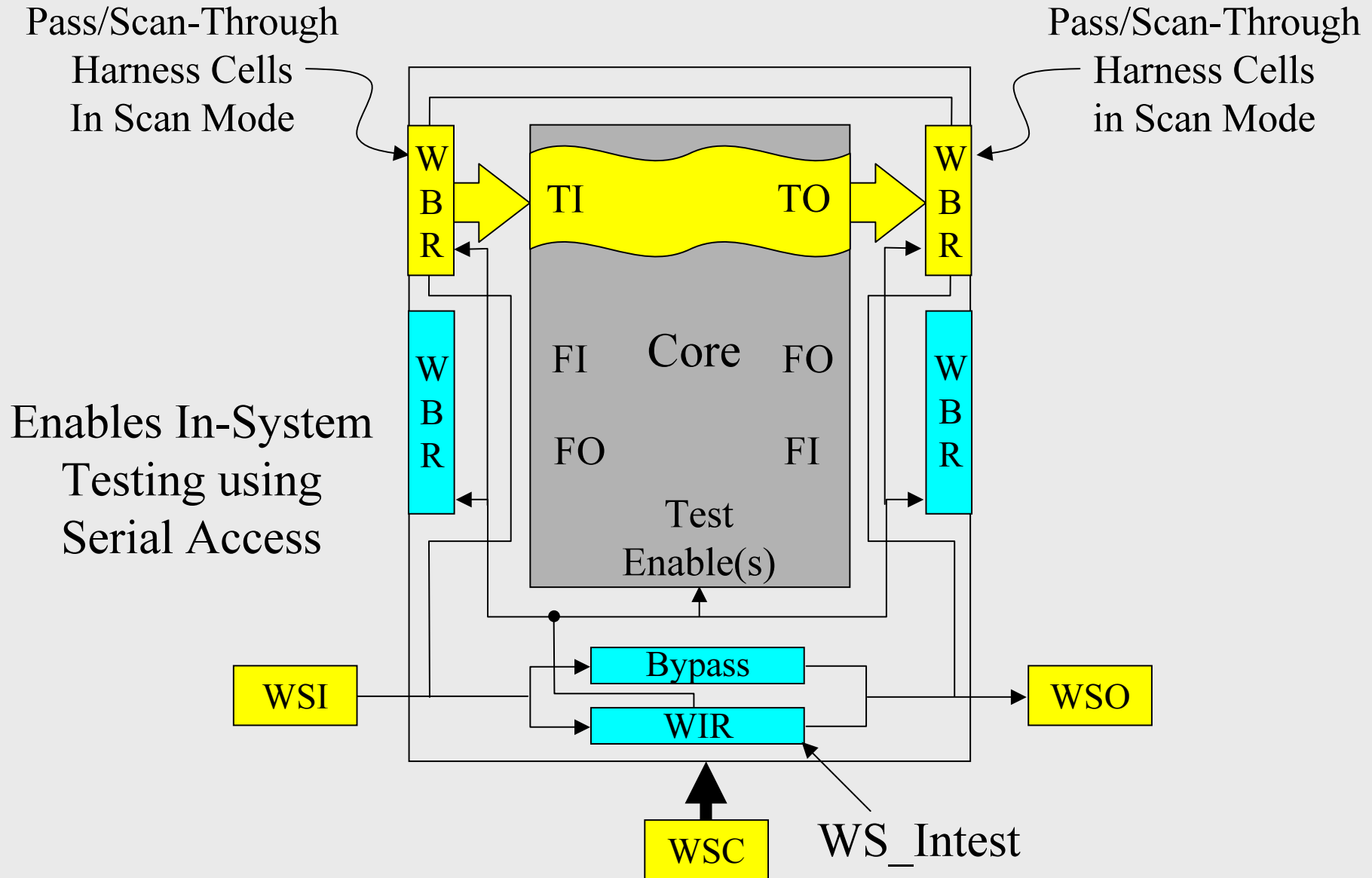

# Summary

- A Standard Core Wrapper has been presented
- Its Architecture is Simple and Extendable
- Its Serial Port is Plug&Play for Standardized Testing
- Its Parallel Port is User Defined for Test Flexibility
- Its Instruction Set is Well Defined and Expandable
- A Draft is in preparation for Ballot in 2003