

Annex D (informative) 802.3 Media specific encapsulation

D.1 Introduction

<<Editor's note: This text all used to be in clause 5 of this specification and a fair amount of the text and diagrams were deemed by review at the face to face to be more informative than normative due to the fact that much of the information was more how to fill in the right data for all of the parts of both 802.3 and 802.1Q rather than being a specification.

The current plan is to take focus on 802.1Q specific requirements common to 802.3 and 802.11 and put that into section 5 with short and necessary only clauses such as VID handling, specifying class A or class B using PCP, etc.

The remaining text and diagrams was deemed useful to keep in the spec to inform new readers not familiar with 802.1Q (audio engineers, 1394 engineers, etc.) to bring them up to speed and show them how the entire frames are formatted without having to chase through a lot of the 802.1 and 802.3 specifications).

Future versions of this specification will move out sections that are need to be normative back to clause 5, in the meantime, this section still contains some normative text with requirements (i.e. "shall") which will be corrected in a future version of this specification such that this section will be fully "informative" in the future>>

This section documents the specific generic encapsulation requirements when running AVBTP over IEEE 802.3 LANs. This covers the following fields:

- a) Destination MAC address: 48 bits
- b) Source MAC address: 48 bits
- c) 802.1Q protocol header: 4 bytes consisting of:
 - Tagged Protocol Identifier (TPID): 16 bits
 - Canonical Format Identifier (CFI): 1 bit
 - Priority Code Point (PCP): 3 bits
 - Virtual Local Area Network (VLAN) Identifier: 12 bits

For 802.1Q operation (VLAN tagged frames) the Ethertype field immediate following the source MAC address is known as the Tagged Protocol Identifier (TPID) field and is set to 8100_{16} . For this case the AVBTP Ethertype is at an offset 4 bytes past the start of this field.

Figure D.7.33 shows an AVBTP frame encapsulated within an 802.3 frame with an 802.1Q header (also known as an 802.1Q VLAN Tag field). For 802.3 frames, this format is required for all AVBTP stream data frames and optional for AVBTP control frames.

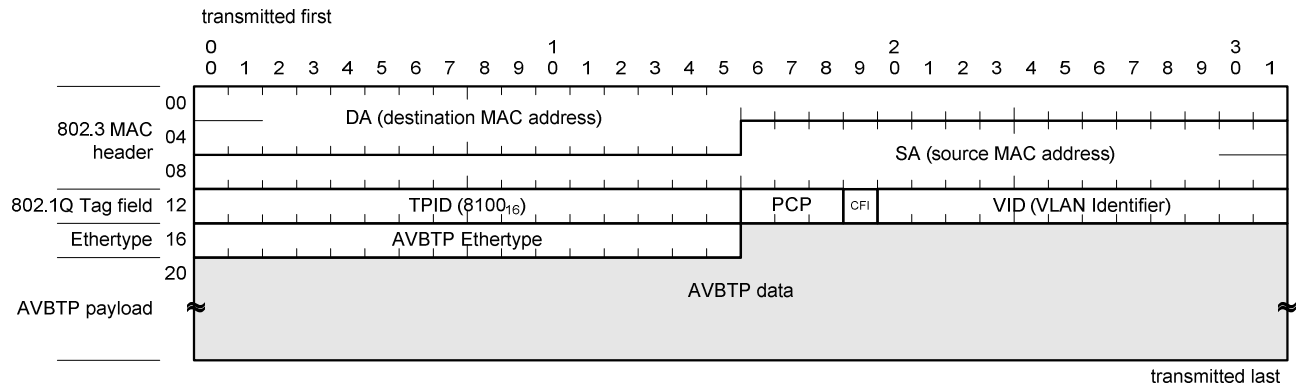

Figure D.7.3 - AVBTP control or stream data frame in an 802.3 frame with 802.1Q tag field

Figure D. 7.44 shows an AVBTP frame encapsulated within an 802.3 frame without an 802.1Q header. This format is optional for AVBTP control frames. This format is not allowed for AVBTP stream data frames as all stream data frames shall be priority encoded for class A or class B traffic thus making the VLAN tag header mandatory.

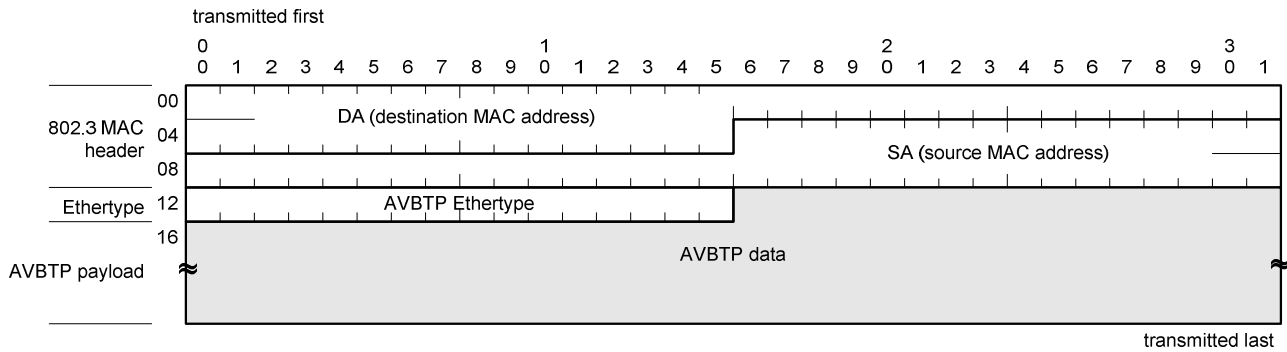

Figure D. 7.4 - AVBTP control frame in an 802.3 frame without an 802.1Q Tag field

D.2 802.3 Fields

D.2.1 802.3 Destination MAC address field

For AVBTP stream data frames, MAC Destination Addresses shall be unique for the Layer 2 network and may either be a unicast or multicast addresses. Multicast addresses may be assigned by use of MAAP (MAC Address Acquisition Protocol) defined in Annex C. Multicast addresses must be guaranteed to be unique per AVBTP stream.

For AVBTP stream control frames, MAC Destination Address may be unicast, multicast or broadcast depending on the specification of the usage of each AVBTP control frame.

D.2.2 802.3 Source MAC address field

For AVBTP stream data frames, MAC Source Addresses shall indicate the senders MAC address of the stream data or control traffic. Per IEEE 802.3 rules, this address shall always be a unicast MAC address.

D.2.3 802.1Q header field

Depending on the subtype of the AVBTP frame, the 802.1Q header may or not be required based on the following rules:

- a) All talkers shall send AVBTP stream data frames with an 802.1Q header present and the PCP field set to indicate either Class A or Class B AVB data.
- b) AVBTP compliant devices may send stream control frames with an 802.1Q header.
- c) All AVBTP compliant devices shall be able to receive and process AVBTP stream data and control frames with an 802.1Q header present.

Additional rules for handling of 802.1Q headers may be listed in subsequent sections for current or future protocols that use AVBTP in current or future versions of this standard, but they **shall** not violate the above general rules, nor **shall** they violate any rules as established in standard IEEE 802.1Q.

The following rules **shall** apply for fields in the 802.1Q header if it is present:

D.2.3.1 802.1Q tagged protocol identifier (TPID) field

All frames with an 802.1Q header field **shall** set the TPID field to a value of 8100₁₆ hexadecimal as required by IEEE 802.1Q.

D.2.3.2 VLAN identifier (VID) field

The VLAN identifier field is used to indicate the 802.1Q VLAN that an AVBTP frame is to be processed on.

All AVBTP stations **shall** be able to support a VID field value of zero to send or receive AVBTP frames.

AVBTP stations are recommended to support other VLAN identifiers, but it is not required.

AVBTP stations not supporting VLANs **shall** still be able to process a received AVBTP frame with 802.1Q header. On AVBTP stations not supporting VLANs the VID **shall** be ignored on receive.

If VLAN identification and knowledge is supported by an AVBTP station, it **shall** discard any received AVBTP frames with a VLAN ID for which it is not a member of the specified VLAN.

D.2.3.3 Canonical Format Indicator (CFI) field

As of the time of the writing of this spec, IEEE 802.3 requires this bit to be zero(0).

D.2.3.4 Priority Code Point (PCP) field

For all stream data frames, AVBTP talkers **shall** set the PCP value to the 802.1Qav specified default or management specified values for either stream class A traffic or stream class B traffic.

NOTE – 802.1 bridges may change the value of the PCP field as it traverses the network.