

# **10Gbps PHY for EPON**

## **Call for Interest**

---

# Supporters

---

Victor Blake,	Advance/Newhouse Communications	Charles Chen,	ImmenStar
Lars Thon,	Aeluros	Eugene Lee,	ImmenStar
Dean Jackson,	Agilent	Niel Ransom,	Independent
Guy Trotter,	Agilent	Drew Perkins,	Infinera
Hai Vodinh,	Allied Telesyn	Chou Yun Lung,	ITRI
David Walsh,	Alloptic	DarZu Hsu,	ITRI
Ketan Gadkari,	Alloptic	Yun-Lung Chou,	ITRI
Vikrama Ditya,	Alloptic	Keiji Tanaka,	KDDI R&D Labs.
Sanjay Sharma,	Ample Communications	Hiroaki Katagawa,	K-Opticom
Petre Popescu,	Astar-ODSM	Dae Kyung Kang,	Korea Telecom
Howard Frazier,	Broadcom	Hiroataka Wada,	NEC
Wael Diab,	Broadcom	Naoto Saeki,	NEC
Scott Powell,	Broadcom	Ed Cornejo,	OpNext
Bill McDonald,	Centillium Communications	Mike Dudek,	Picolight
Joe Decarolis,	Centillium Communications	Brad Booth,	Quake Technologies
Zhong Deqiang,	China Netcom	Rick Li,	Salira Systems
Shen Cheng Bin,	China Telecom	Byeong Hoon Kim,	Samsung Electronics
Wang Bo,	China Telecom	Eric Hyunsurk Ryu,	Samsung Electronics
Ching-Sheu Wang,	Chunghwa Telecom	Geoffrey Garner,	Samsung Electronics
Russ Gyurek,	Cisco Systems	Jung Won Park,	Samsung Electronics
Paul Voois,	ClariPhy Communications	Yosuke Komiyama,	Softbank BB
William Keasler,	Conexant Systems	Ed Boyd,	Teknovus
David Hare,	Conexant Systems	Glen Kramer,	Teknovus
Seuk-Jin Kang,	Corecess	Ryan Hirth,	Teknovus
Steven Swanson,	Corning	Sanjay Kasturia,	Teranetics
Ming Wu,	Delta Electronics	Denis Beaudion,	Texas Instruments
Dong Soo Lee,	ETRI	Jaafar Haji Mohamad Abu Bakar,	Telecom Malaysia
Hark Yoo,	ETRI	Sahrul Hilmi Ibrahim,	Telecom Malaysia
Bin Yeong Yoon,	ETRI	Alex Conta,	TranSwitch
Douglas Cheng,	Fiberxon	Eric Lynskey,	UNH IOL
Hu Baomin,	FOTEK Optoelectronics	Henry Tzeng,	UTStarcom
Liu Wu,	FOTEK Optoelectronics	Frank Chang,	Vitesse

# Objectives for this Meeting

---

- To **measure the interest** in starting a study group to develop a standards project proposal (a PAR and 5 Criteria) for **10 Gbps PHY for EPON**.
- We don't need to
  - Fully explore the problem
  - Debate strengths and weaknesses of solutions
  - Choose any one solution
  - Create PAR or five criteria
  - Create a standard or specification

# The Brief History of EPON

- **Nov 2000**
  - CFI for Ethernet in the First Mile
- **Jan 2001**
  - The first Study Group meeting
- **Sep 2001**
  - The first Task Force meeting
- **Jun 2004**
  - IEEE Std 802.3ah–2004 is approved by RevCom and IEEE SA SB



## EPON Today...

- **... is in commercial deployments:**
  - **Carriers:** China Netcom, KDDI, K-Opticom, Korea Telecom, NTT, SBB, ...
  - **Deployed volume:** 3 million lines
  - **Installed CO capacity:** 10 million ports
- **... has broad manufacturing base:**
  - **Optics/Transceivers/PHY:** Delta Electronics, ETRI, Fiberxon, Hitachi/Lightron, NEC, Sumitomo, Vitesse, Zenko
  - **ASIC:** ETRI, Centillum, Conexant, Immenstar, GW, Passave, Teknovus, ...
  - **System:** Allied Telesyn, Alloptic, Corecess, Dasan/Siemens, Entrisphere, Fiberhome, Fujitsu, Furukawa, Hitachi, Huawei, Hyundai, Mitsubishi, Nayna, NEC, OKI-Fujikura, Salira, Samsung, Sumitomo, UTStarcom, ZTE, ...
  - **Test Equipment:** Agilent, Fujitsu
- **Since IEEE Std 802.3ah approval, equipment cost has decreased by 50% and optics cost has decreased by 70%**

# Why a New CFI Now?

## Good problem

- **Ethernet PON opened floodgates for advanced services**
  - Video-on-Demand
  - High-definition IP TV
  - Time-shifted broadcast
  - Online video games
- **Users began to accept, like, and demand more bandwidth-intensive services**
  - File sharing, picture uploading, video conferencing
  - More simultaneous IP TV channels
  - More on-demand, less broadcast (“information pull” instead of “information push”)
- **EPON’s success has created a strong demand for greater bandwidth**
- **Carriers are looking for a next generation solution**
  - Compatible with existing outside plant
  - Compatible with existing NMS and OAM

## Bad solutions

- **Carriers are considering non-IEEE PON architectures that provide more bandwidth**
- **Manufacturers are beginning to develop proprietary higher-speed EPON solutions**



# Next Step: "10x" EPON

---

- Proposed scope of study:

## 10 Gbps PHY for EPON

- 10 Gbps downstream / 10 Gbps upstream
  - 10 Gbps downstream / 1 Gbps upstream
  - one or both
- A very focused project
  - No changes to other EPON sublayers
    - MPCP, OAM ...

# 10G-EPON Market Potential

---

Keiji Tanaka, KDDI R&D Labs

Ketan Gadkari, Alloptic

Lowell Lamb, Teknovus

# Telcos Must Evolve or Else...

---

- Telcos experience intense pressure from cable, satellite, & wireless providers
- To meet the new market requirements, carriers worldwide rapidly are adopting triple-play, video-centric residential services:
  - **US:** AT&T (formerly SBC), AT&T (formerly BellSouth), Verizon
  - **Asia:** China Netcom, China Telecom, CHT, KDDI, K-Opticom, Korea Telecom, NTT
  - **Europe:** British Telecom, NTL, Telefonica, ...
- Universal theme of the new services: **much more bandwidth**
  - Broadcast TV (with an increasing fraction of HDTV)
  - Video-on-Demand (time-shifting, network-based PVR)
  - On-line interactive games
  - High-speed Internet
  - IP video surveillance
  - Business metro Ethernet access

# Real Examples of Advanced Services

## IP Telephony

- Primary phone service:
  - Toll-grade
  - Multi-functionality
  - Emergency call handling
- Customer keeps original phone number



## IP Video

- DVD-quality video
- Competitive broadcast TV (100's of channels)
  - MTV, ESPN, etc.
- Rich Video-on-Demand libraries (~4000 titles)
  - Hollywood movies, dramas, etc.



## Data

- Internet Access (tiered services)
- Remote Back-up/Restore



## Other

- Online gaming
- ~3,000 Karaoke-on-Demand tracks
- Services integrated with mobile phone
  - VoD reservation, TV guide, through mobile phone.





# FTTx Projected Growth in Japan

Estimated by Yano Research Institute, Ltd. March 2005

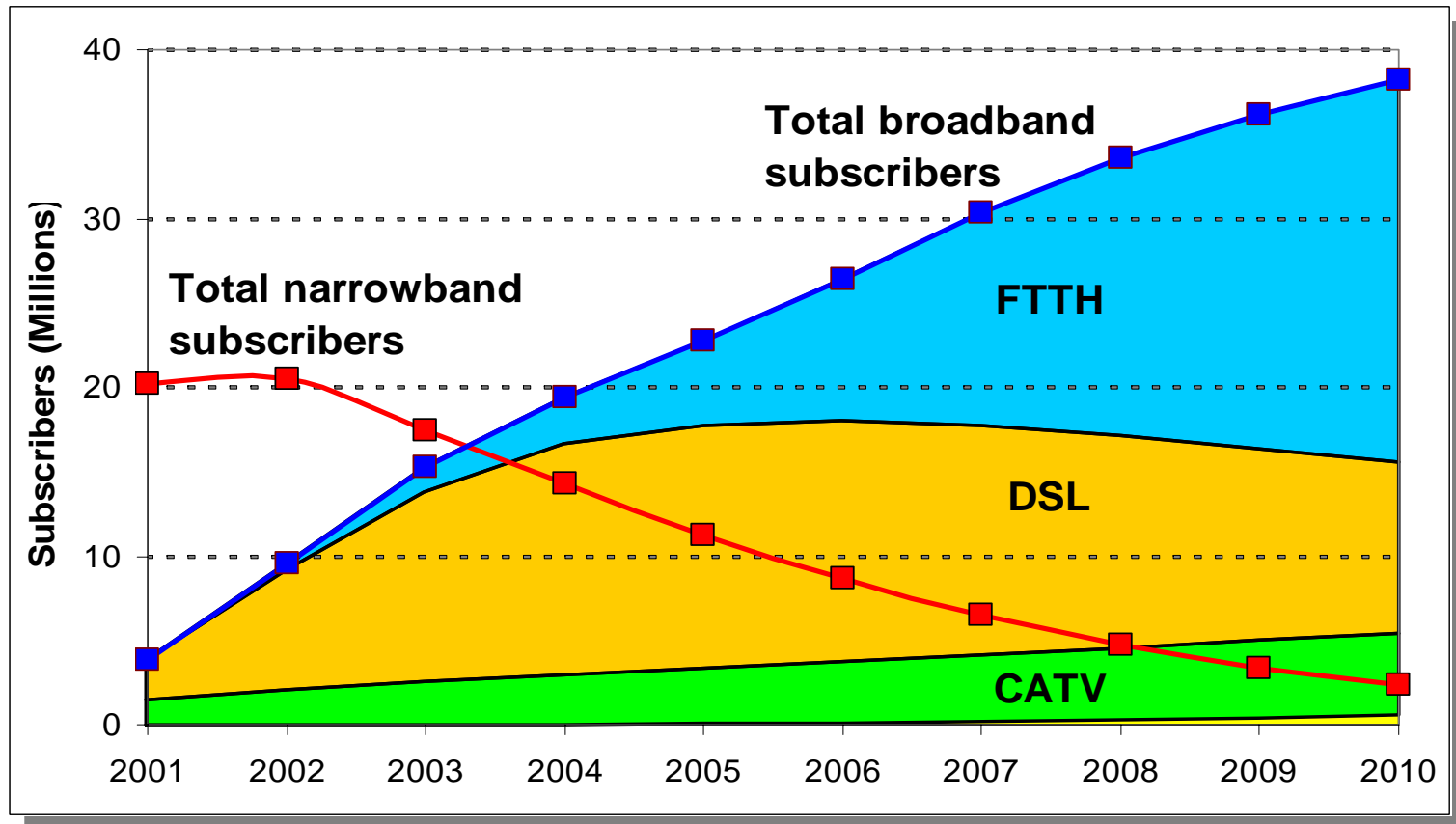

- Forecast of internet access penetration (no. of subs) by connection type for Japan.
- Other markets follow similar trends with different time scales.

# FTTx Trend is Clear...

- FTTx is still in the early stages of growth
- Greenfield deployments defaulting to FTTH
- FTTN plans adopted by many US and European carriers

## Worldwide FTTx Forecast

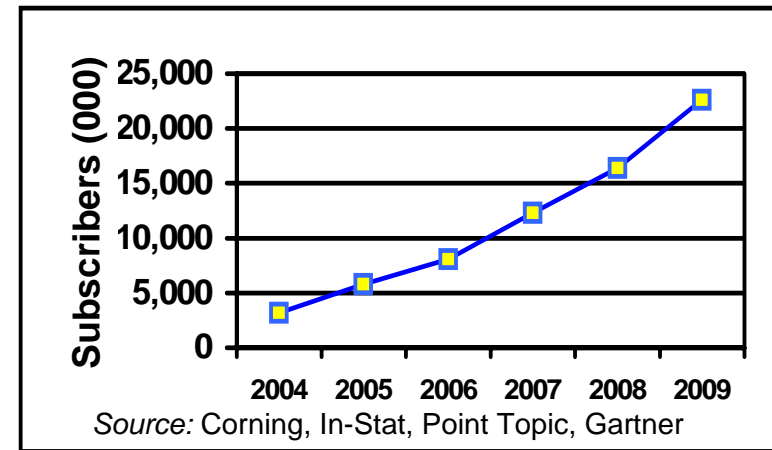

## North America FTTx Forecast - Annual

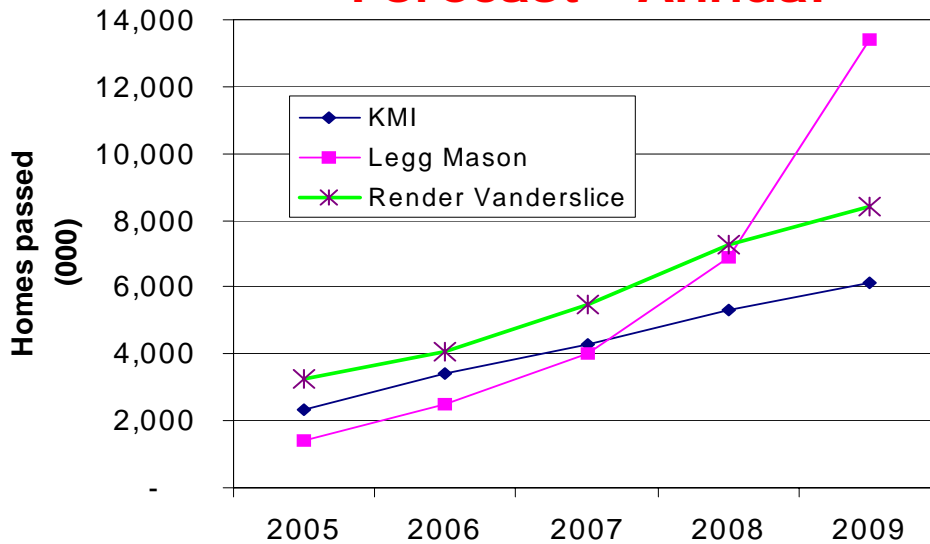

March 7, 2006

10G EPON CFI v.21

## EU25 FTTx Forecast

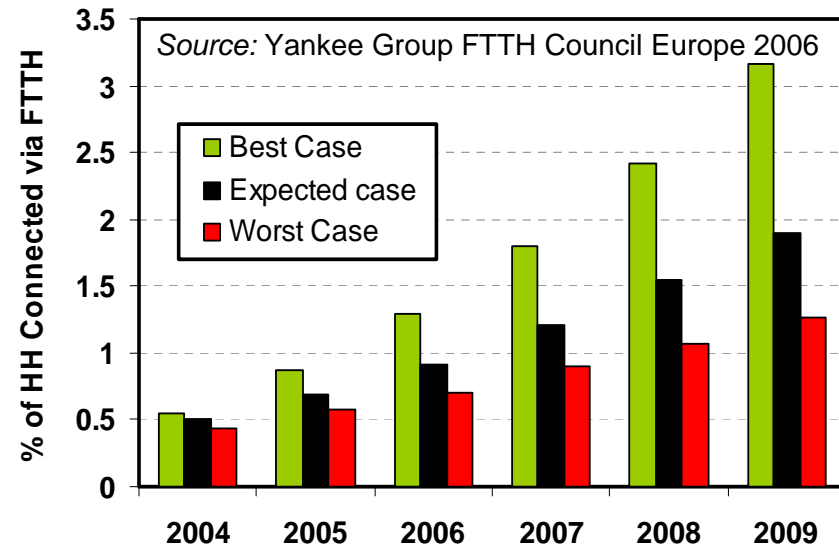

Denver, Colorado

12

# 10G EPON for Digital Television

Service Offerings	
Today	Near Future (2010)
<ul style="list-style-type: none"> <li>• Broadcast</li> <li>• Video-on-Demand</li> </ul>	<ul style="list-style-type: none"> <li>• Time-shifted / narrowcast</li> <li>• All-channel personal video recorder</li> <li>• Picture-in-picture / split screen</li> <li>• Digital cinema distribution</li> <li>• Personal multimedia publishing</li> <li>• Residential and business digital video surveillance</li> </ul>

Bandwidth per Channel	
Today	Near Future (2010)
<ul style="list-style-type: none"> <li>• Standard Definition TV (SDTV)                             <ul style="list-style-type: none"> <li>• 2 Mbps per channel</li> </ul> </li> </ul>	<ul style="list-style-type: none"> <li>• High-Definition TV (HDTV)                             <ul style="list-style-type: none"> <li>• ~10 Mbps per channel</li> </ul> </li> <li>• Large Screen Digital Imagery (LSDI)                             <ul style="list-style-type: none"> <li>• Standardized by ITU-T J.601</li> <li>• 40 to 160 Mbps per channel</li> </ul> </li> </ul>

Number of Channels	
Today	Near Future (2010)
<ul style="list-style-type: none"> <li>• 30 ~ 100 channels</li> </ul>	<ul style="list-style-type: none"> <li>• 1000 or more channels                             <ul style="list-style-type: none"> <li>• Mix of SDTV, HDTV, LSDI</li> </ul> </li> </ul>

Forecast of US Households Using HDTV

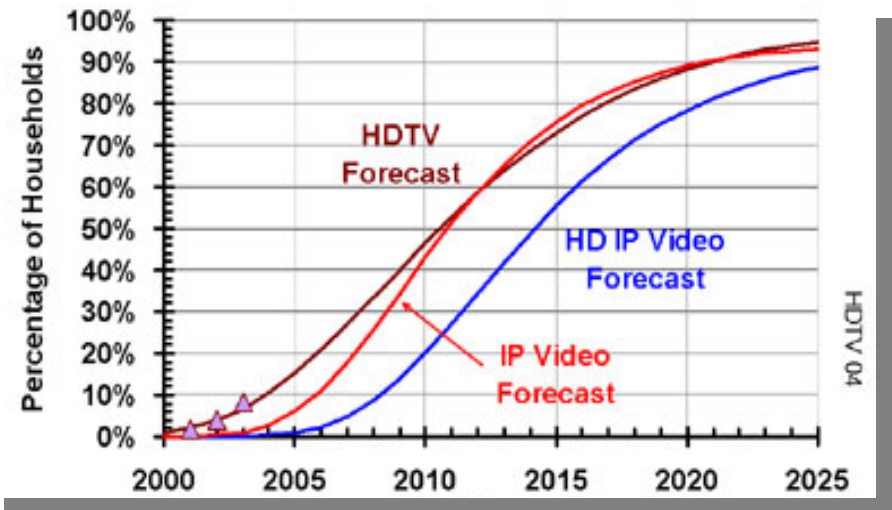

Reproduced with permission from Technology Futures, Inc.

For now, AT&T will offer 200 channels, though it expects to offer 1,000 or more channels when it expands the service to other markets in about six months. Its channel lineup already includes major networks as well as ESPN, HBO, the Discovery Channel, the Disney Channel, MTV, the History Channel, USA, CNN, National Geographic and others.

The Wall Street Journal  
January 5, 2006

# 10G EPON for Digital Home

---

- In 2010, residential gateways will require *much* more bandwidth
  - 3-5 STBs/home with built-in digital video recorders
  - Large fraction of television will be HDTV
  - Large fraction of television will be on-demand/time-shifted
  - Gigabit UNIs in home networks will be ubiquitous
  - AV Bridges will be ubiquitous
- **Access network bandwidth must grow beyond 1 Gbps**

# 10G EPON For Wireless Back-Haul

- 4<sup>th</sup> Gen mobile communication will be ubiquitous
  - Bandwidth: ~30Mbps/user, 100M~1Gbps/access point
  - Access point coverage will decrease
  - Number of access points will increase
  - EPON is a natural back-haul solution for the 4<sup>th</sup> Gen access points
- Next generation wireless back-haul
  - 802.11n: up to 100 Mbps per device
  - 802.16e: up to 70 Mbps per access point
- **Access bandwidth must grow beyond 1 Gbps**

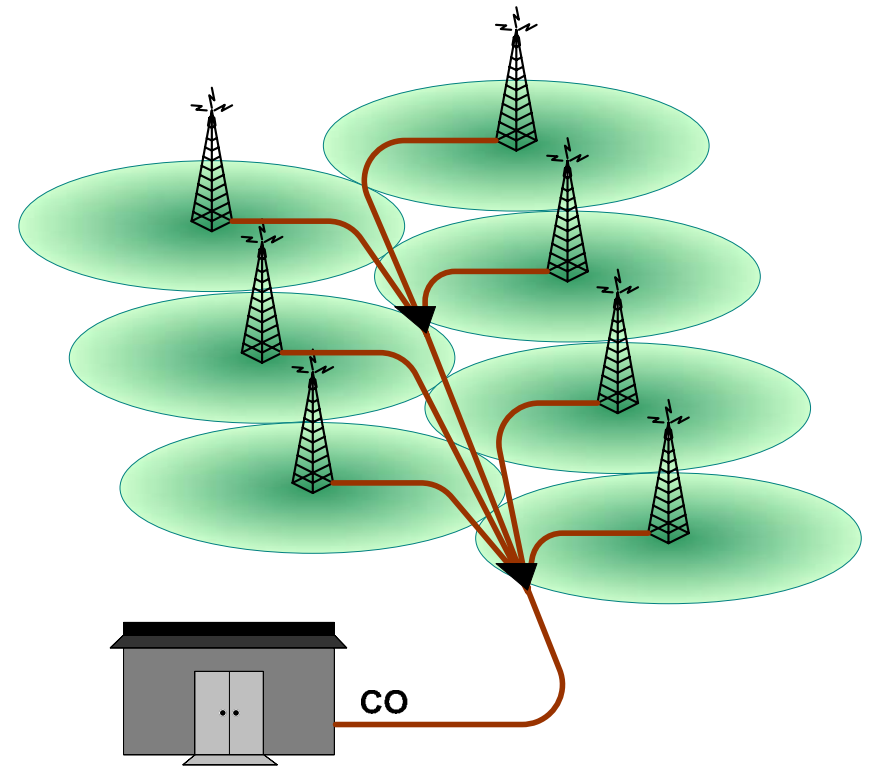

# 10G EPON for MDU Market

- A large fraction of broadband users lives in Multiple Dwelling Units (MDUs)
- Each of 16 MDU ONUs can provide service to 24–48 subscribers, a total of 384-768 subscribers per EPON

<b>Broadcast Video</b>	100 channels x 10 Mbps/channel =	<b>1.0 Gbps</b>
<b>Video on Demand</b>	10 Mbps/channel x 2 channels/user x 24 users/ONU x 16 ONUs/PON x 30% take rate*	<b>2.3 Gbps</b>
<b>Video Conferencing &amp; Surveillance</b>	10 Mbps/user x 24 users/ONU x 16 ONUs/PON x 10% take rate	<b>0.4 Gbps</b>
<b>Internet</b>	5 Mbps/user x 24 users/ONU x 16 ONUs/PON x 50% take rate	<b>1.9 Gbps</b>
<b>Gaming</b>	10 Mbps/user x 24 users/ONU x 16 ONUs/PON x 30% take rate	<b>1.2 Gbps</b>
<b>Required PON bandwidth =</b>		<b>6.8 Gbps</b>

March 7, 2006

10G EPON CFI v.21

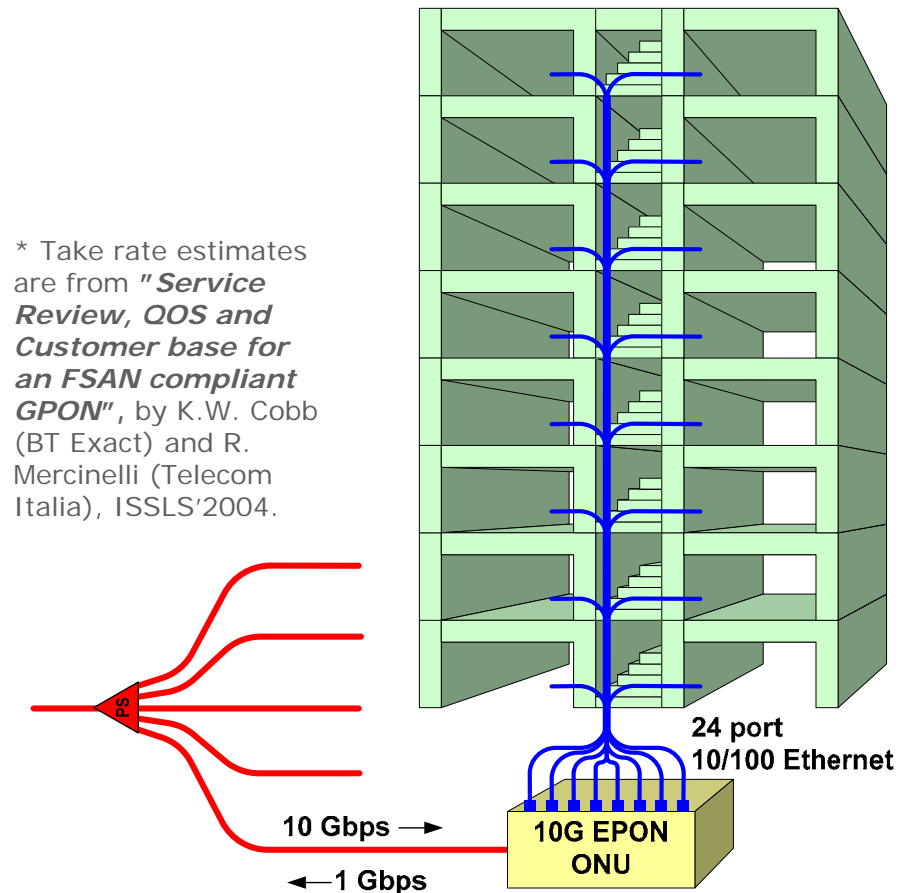

Denver, Colorado

16

# Summary

---

## Why 10 Gbps for access network?

- Optical feeders with bandwidth of ~10 Gbps are necessary for ...
  - Advanced video services
  - Gigabit-capable home networks
  - 4<sup>th</sup> generation mobile communication with bandwidth per access point of ~1Gbps
  - MDU market

## Why PON?

- PON reduces CAPEX and OPEX
  - Accommodates a large number of FTTx users or large number of mobile access points efficiently
  - Reduces the footprint and power consumption of central office equipment
  - Reduces fiber deployment and repair cost

# Connecting Two Ethernet Networks

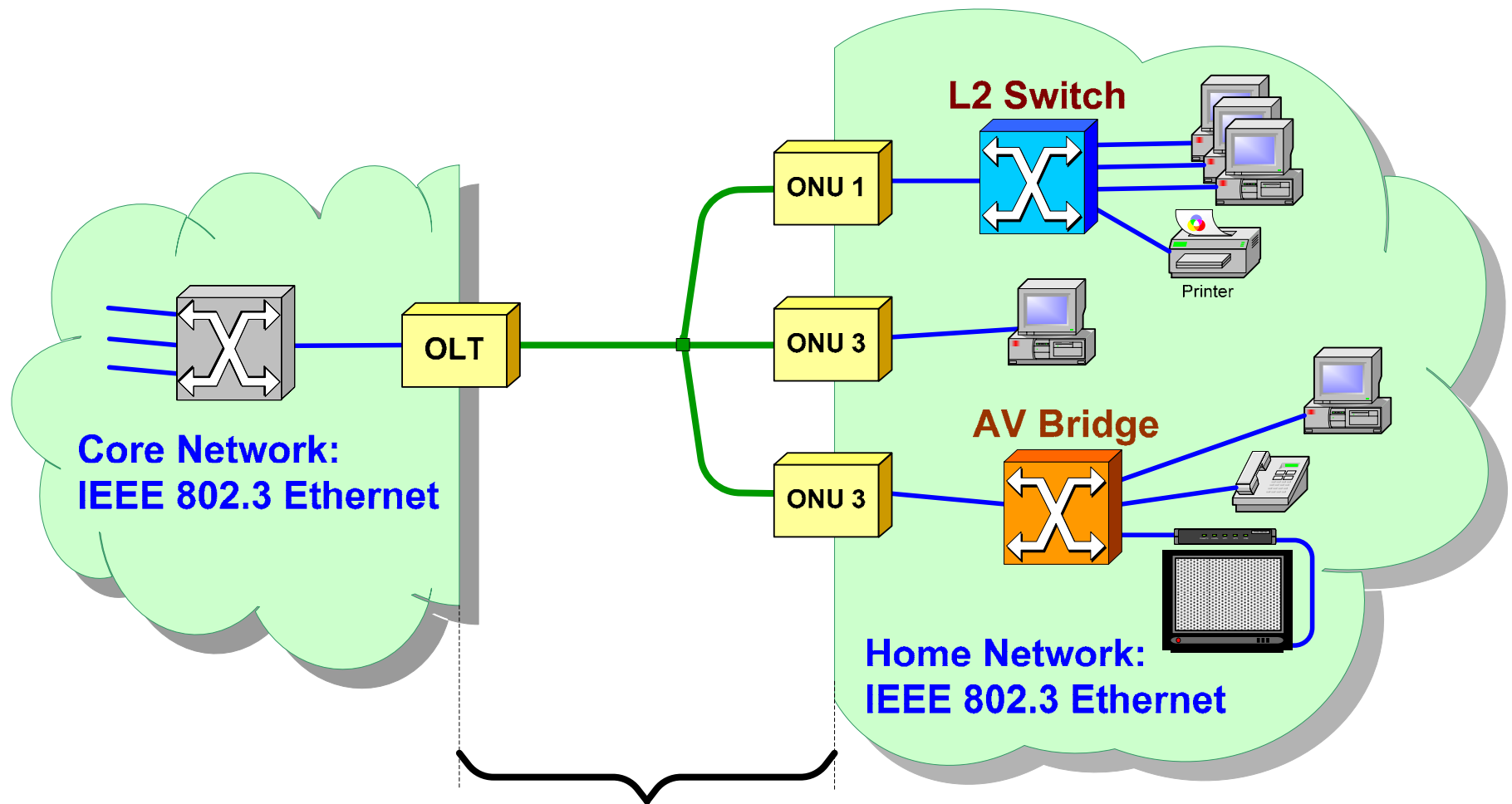

**Ethernet-over-GEM-over-SONET or Ethernet?**  
**ITU-T GPON or IEEE EPON?**

# Path Forward

---

- PON will be deployed in high volume in the access network
  - A fully standardized solution is required
- IEEE 802.3 EPON is in mass deployment now
  - 200k+ lines/month worldwide
  - Lower cost is EPON's key advantage
- To meet increased bandwidth demand, EPON must grow to 10 Gbps

**We recommend that IEEE 802.3 charter a Study Group to investigate the development of a Next Generation EPON standard.**

# 10G-EPON

## Technical Feasibility

---

Bin Yeong Yoon, ETRI

Howard Frazier, Broadcom

Dong-Soo Lee, ETRI

Hark Yoo, ETRI

Keiji Tanaka, KDDI R&D Labs.

# Evolution of EPON Technology

## 802.3ah: 1 Gbps downstream / 1 Gbps upstream

- ✓ The first commercial FTTH technology with Gigabit bandwidth deployed in the world
- ✓ Currently specified in IEEE Std. 802.3-2005

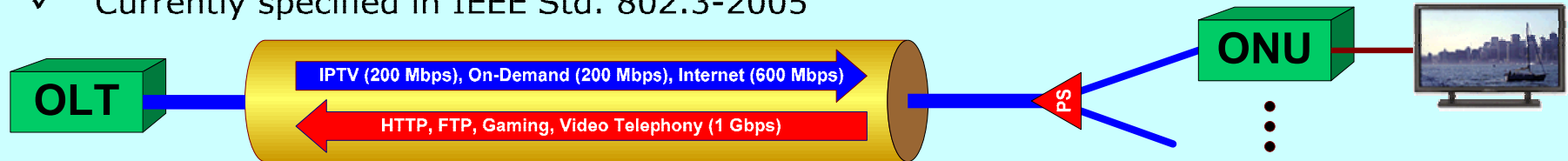

## Option 1: 10 Gbps downstream / 1 Gbps upstream

- ✓ Providing more downstream bandwidth to support advanced digital TV services
- ✓ CATV replacement

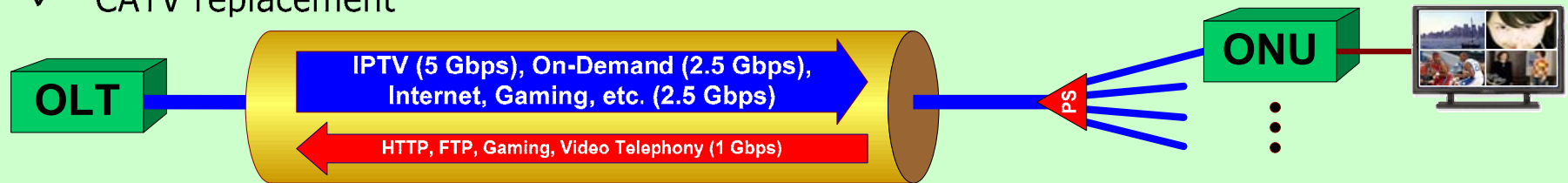

## Option 2: 10 Gbps downstream / 10 Gbps upstream

- ✓ Support for advanced, bandwidth-intensive upstream and downstream services
- ✓ Support for more subscribers / dense deployments / MDU markets

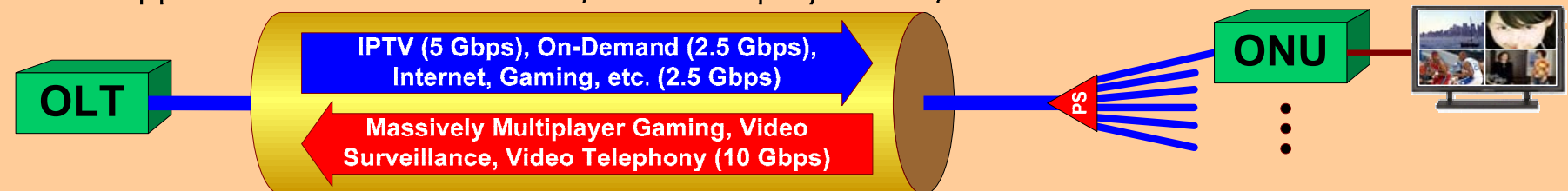

# Video Delivery Options

## 802.3ah: 1 Gbps downstream / 1 Gbps upstream

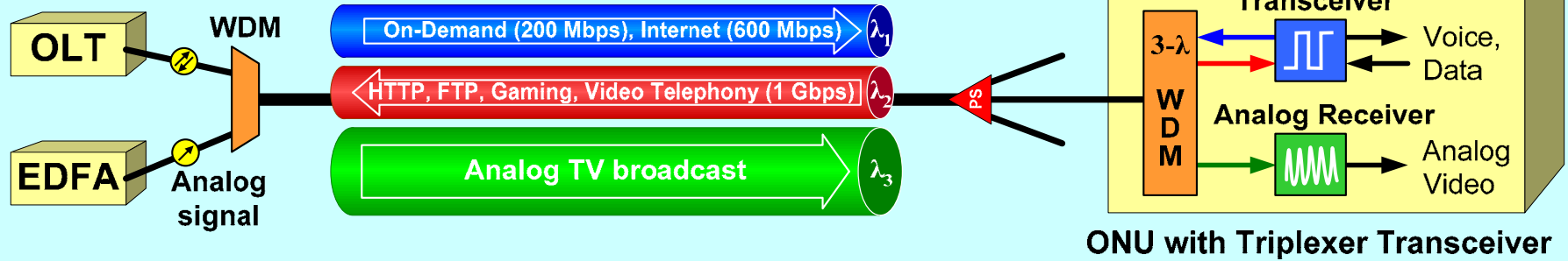

## Option 1: 10 Gbps downstream / 1 Gbps upstream

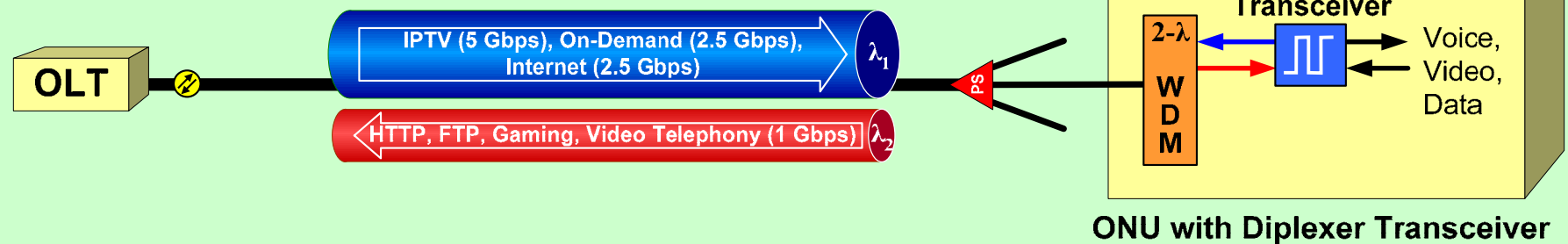

- 10G EPON eliminates the bandwidth need to provision a third wavelength for video
- 10G EPON simplifies architecture for video delivery
- 10G EPON facilitates IP convergence

# Complements Other IEEE 802 Task Forces

- 10G EPON complements activities of other IEEE 802 Task Forces
  - **802.3ae, 802.3ak, 802.3an:** 10G EPON provides line rate matching 10G Ethernet interconnects in a central office;
  - **802.1 AV Bridges TG (Residential Ethernet):** 10G EPON will deliver all video in digital format, consistent with the main premise of the 802.1 AV Bridges TG.

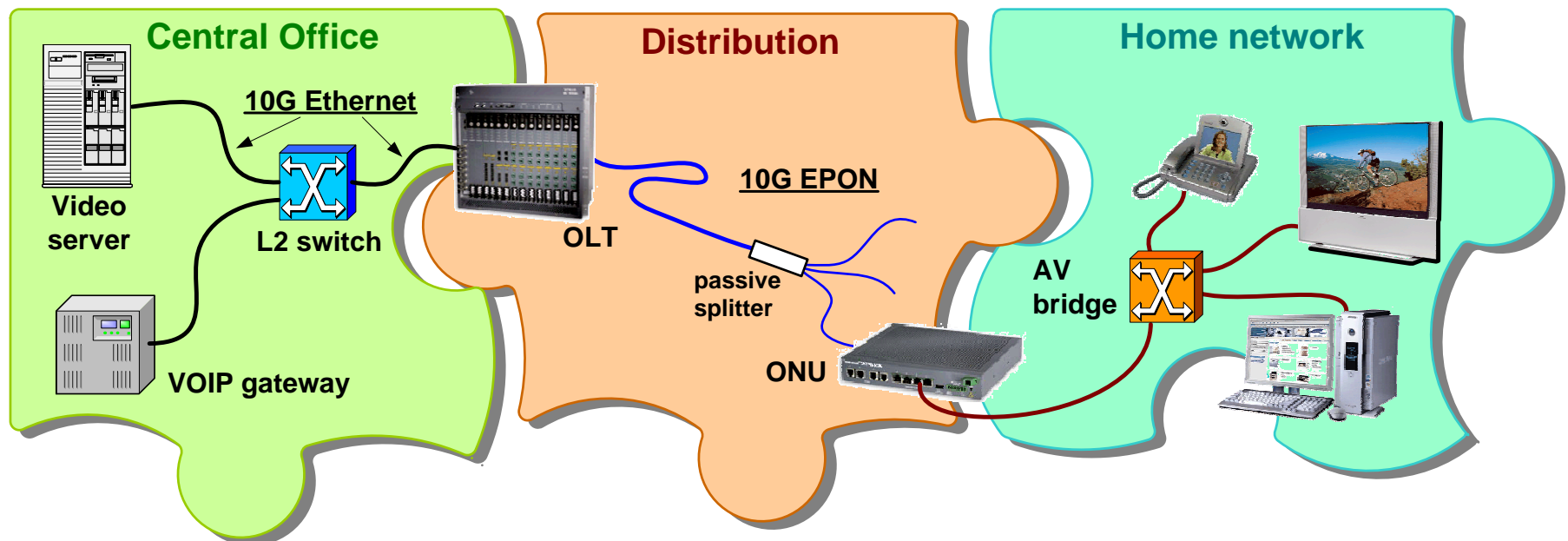

# 10G EPON Downstream Power Budget

Optical components for **10Gbps downstream** supporting 16 ONUs at 20 Km are **commercially available**

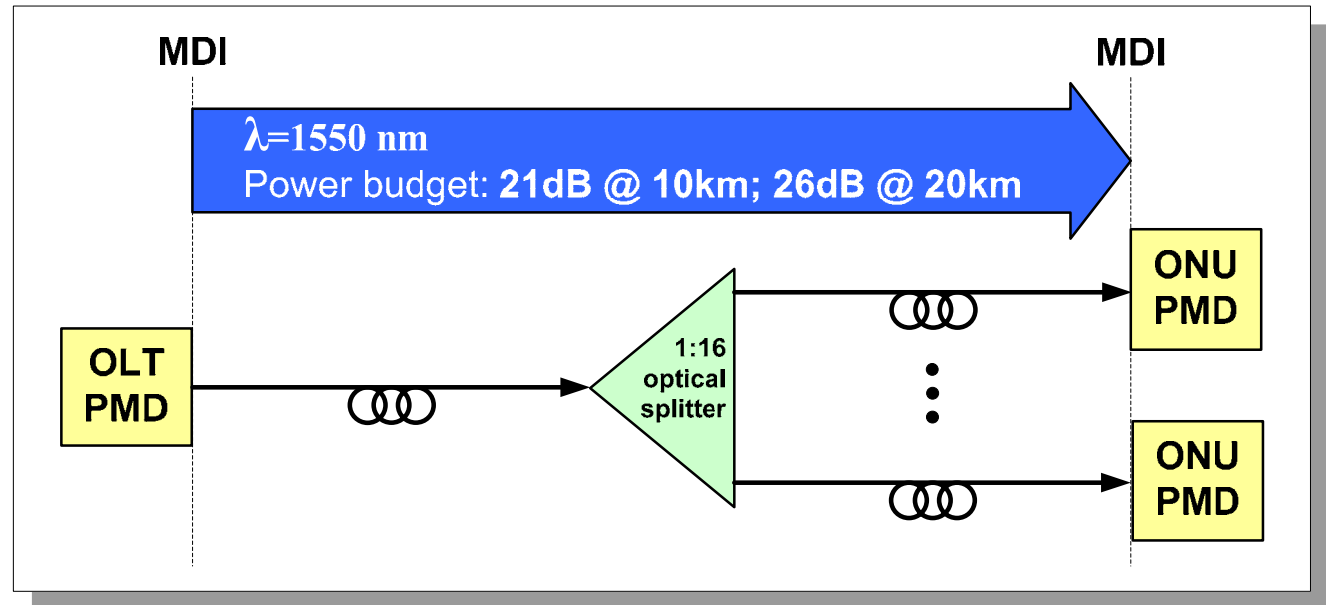

Distance	Required Power Budget	Tx Launch Power (OLT)	Rx Sensitivity (ONU)	FEC Gain	Available Power Budget
10 km	<b>21 dB</b>	+1dBm (EML)	-17dBm (pin-PD)	3dB	<b>21dB</b>
20 km	<b>26 dB</b>	+1dBm (EML)	-24dBm (APD)	3dB	<b>28dB</b>

**EML** - Electro-absorption Modulated Laser

# 2.5G×4 CWDM-EPON Downstream Power Budget

Optical components for **4×2.5Gbps downstream** supporting 16 ONUs at 20 Km are **commercially available**

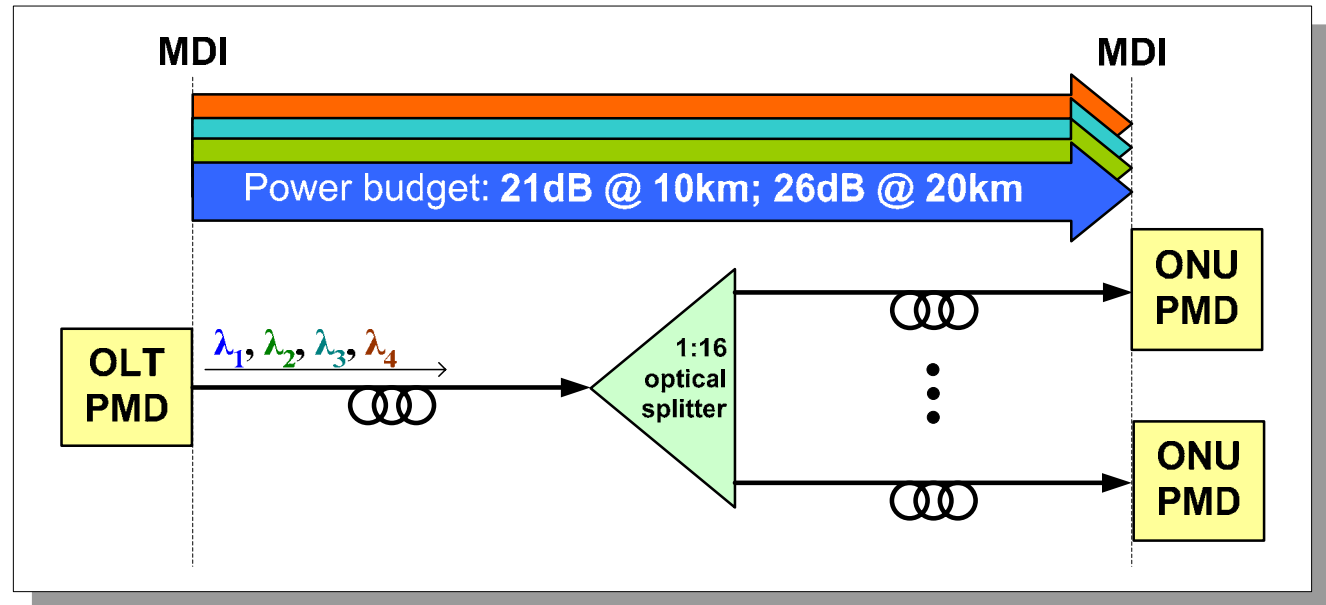

Distance	Required Power Budget	Tx Launch Power (OLT)	Rx Sensitivity (ONU)	FEC Gain	Available Power Budget
10 km	<b>21dB</b>	0dBm (DFB)	-23dBm (PIN)	3dB	<b>26dB</b>
20 km	<b>26dB</b>	+2dBm (DFB)	-23dBm (PIN)	3dB	<b>28dB</b>

# 10G EPON Upstream Power Budget

Optical components for **10Gbps upstream** supporting 16 ONUs at 20 Km are **commercially available**

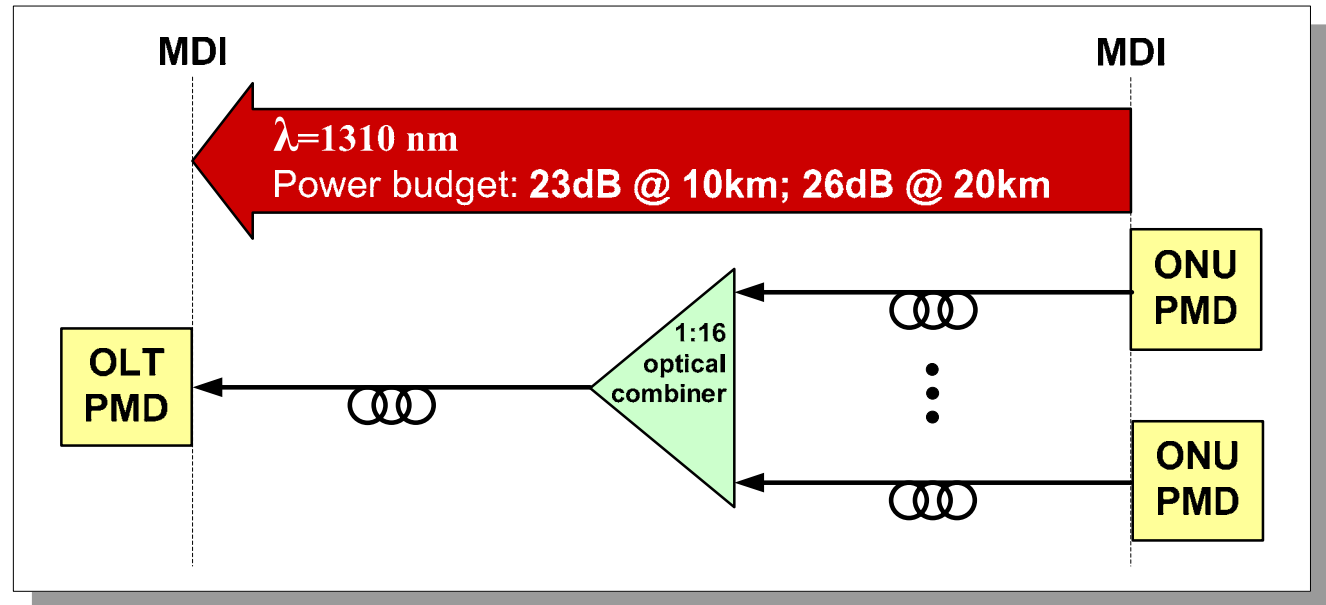

Distance	Required Power Budget	Tx Launch Power (ONU)	Rx Sensitivity (OLT)	FEC Gain	Available Power Budget
10 km	<b>23 dB</b>	-1dBm (DFB-LD)	-24dBm (APD)	3dB	<b>26dB</b>
20 km	<b>26 dB</b>	-1dBm (DFB-LD)	-24dBm (APD)	3dB	<b>26dB</b>

# 10G EPON is Feasible

---

- Technically, there are no obstacles for 10G EPON
  - Acceptable 10G EPON system can be implemented using components available for 10GbE
  - Use 10G MAC, No changes to MPCP
  - Chipsets such as TIA, CDR, and LD driver suitable for burst mode can be developed to enhance the L2 performance of 10 Gbps upstream
- Changes can be confined to the PHY
  - **PCS**: FEC function to support 64B/66B for 10Gbps
  - **PMD and PMA** parameters for 10Gbps downstream
  - **PMD and PMA** parameters of 10Gbps Burst Mode upstream
  - Consider both 10Gbps serial and 4x2.5Gbps CWDM
- This would be a much smaller and quicker project than P802.3ah

# Feasibility Test for 10G-down/1G-up

- ETRI tested prototype OTRx modules for 10G downstream/  
1G upstream to support **128 ONUs at 10km**

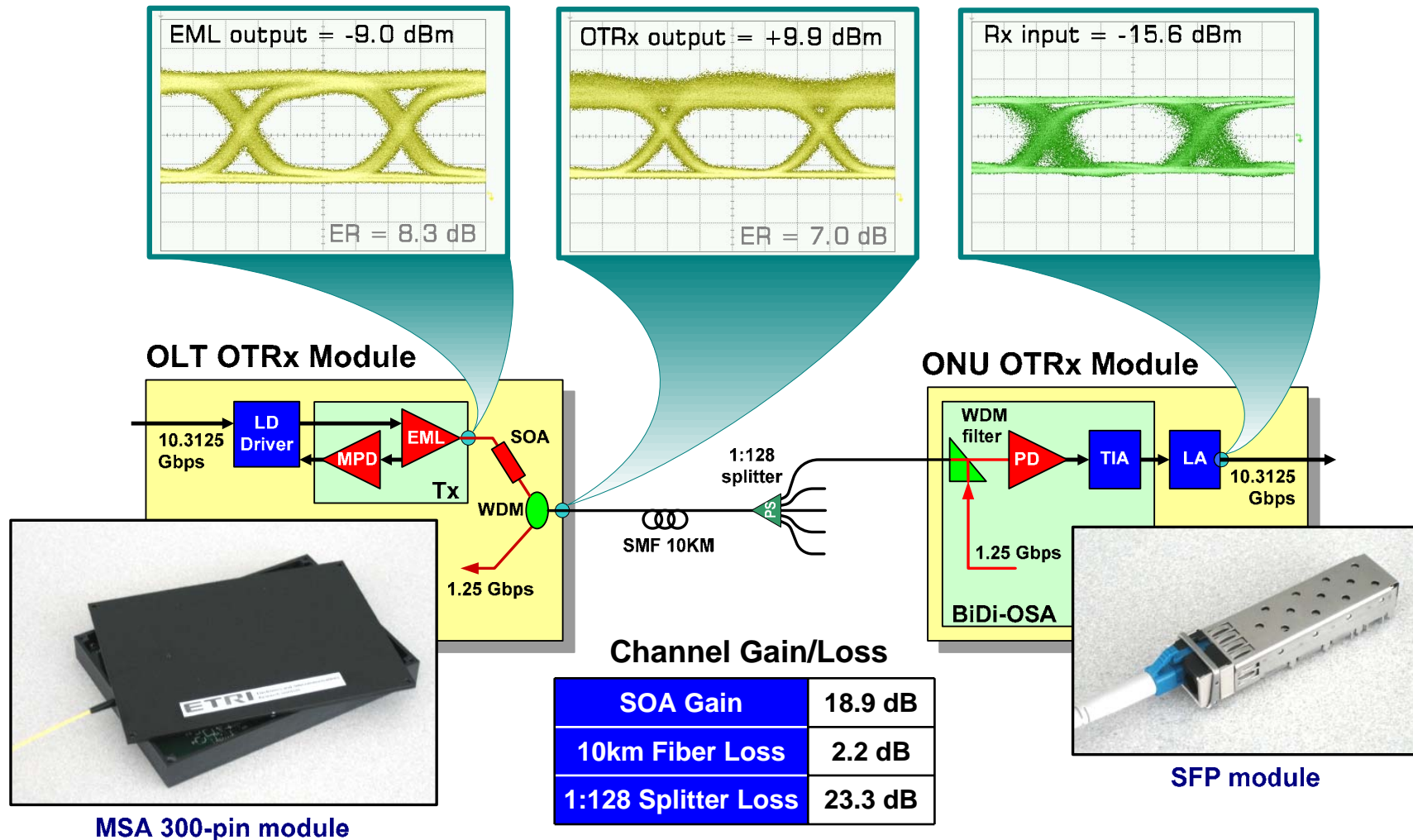

# Performance of 10G-down/1G-up

- **Estimated L2 throughput of 9 Gbps exceeds that of CATV with DOCSIS 3.0**
  - DOCSIS 3.0 theoretically achieves 5 Gbps downstream
- **Baseline Efficiency for 128 ONUs**

Parameter		Downstream 10G	Upstream 1G
EPON Overhead Components [%] <sup>1)</sup>	Control Channel	0.86	8.6
	Guard-band	-	18.00
	Discovery	-	0.06
	FEC <sup>2)</sup>	9.25	9.25
<b>Average L2 Throughput (with FEC)</b>		<b>9.00 Gbps</b>	<b>680 Mbps</b>
<b>Average L2 Throughput (without FEC)</b>		<b>9.91 Gbps</b>	<b>749 Mbps</b>

1) Calculated for 1 ms fixed cycle time

2) Calculated for empirical (tri-modal) network traffic

# Feasibility Test for 10G-down/10G-up

- KDDI R&D Lab has experimentally evaluated feasibility of a 10Gbps EPON system using XENPAK-based burst-mode Tx/Rx

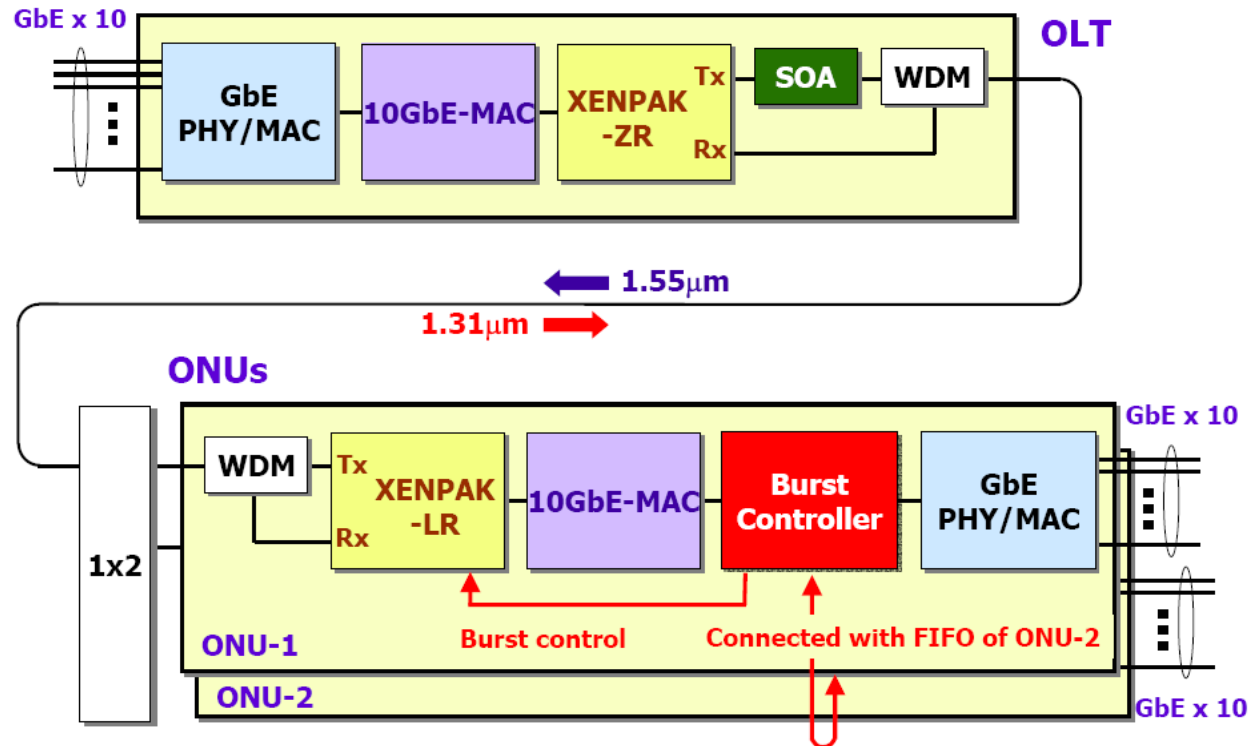

# Performance of 10G-down/10G-up

---

- Acceptable 10Gbps EPON system was proven by using components available for 10 GbE

## Optical performance

Loss budget : > 23dB w/o FEC

## L2 Performance

Throughput : **10/4 Gbps** for DS/US w/o frame loss (BER<1.0E-12)

Latency : **50/650μsec** for DS/US

## Multi-service accommodation capability

No performance degradation of GE-PON/VDSL traffic



**10GbE-PON is considered to be effective and feasible as a next-generation optical access network system.**

For more details, please refer to

K. Tanaka and N. Edagawa, "Experimental Study on 10Gbit/s EPON System Using XENPAK-Based Burst-Mode Transceivers", In Proceedings of ECOC'2005, September 2005, Glasgow, Scotland.

# Summary

---

- **ETRI demonstrated prototype Option 1 system**
  - 10 Gbps downstream / 1 Gbps upstream
- **KDDI R&D Labs demonstrated prototype Option 2 system**
  - 10 Gbps downstream / 10 Gbps upstream
  - Built with commercial of-the-shelf components for continuous mode of operation (non-burst mode)
- **There are no obstacles to 10G EPON in terms of technical feasibility**
- Standardization issues restricted to the PHY layer
  - Potential FEC function of the PCS sublayer to support 64B/66B coding
  - PMD and PMA parameters for 10 Gbps downstream
  - PMD and PMA parameters of 10 Gbps burst mode upstream

# 10G-EPON

## Testing and Interoperability

---

Eric Lynskey, UNH IOL

Dean Jackson, Agilent

Guy Trotter, Agilent

# Testing and Interoperability

## EPON Testing

- ❑ Interoperability and compliance testing ongoing since 2004.
- ❑ Numerous EPON Conformance and Interoperability Test Suites were developed
- ❑ Test equipment is out now, and more will be here soon

## 10GbE Testing

- ❑ Interoperability and compliance testing ongoing since 2002.
- ❑ High level of inter-operability, even exceeding limits imposed by standard
- ❑ Test equipment is already out there
- ❑ 10GbE has a proven track record of success

## 10G-EPON Testing

- ❑ Experience with EPON testing and 10GbE testing
- ❑ Reliable 10G-EPON test suites can be developed quickly

# Agilent N2X 1G EPON Analyzer

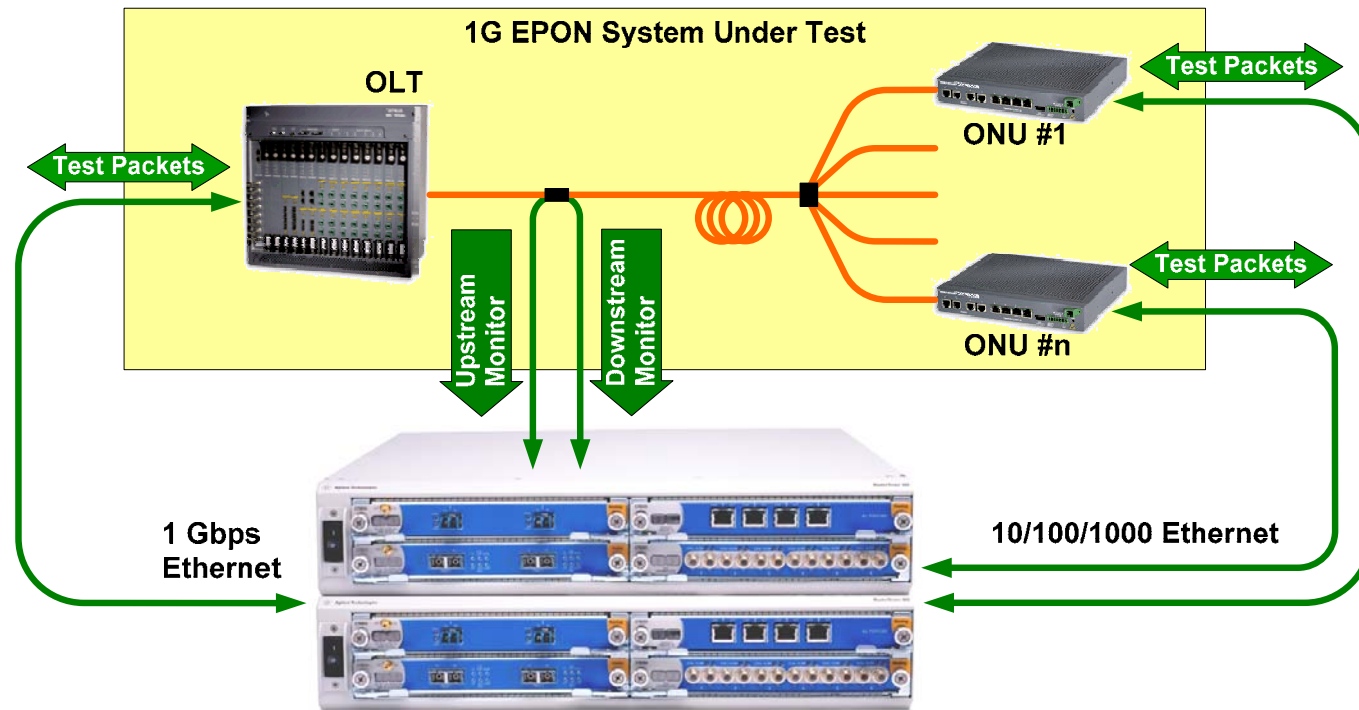

- **The Agilent N2X 1G EPON Performance Analysis System:**
  - Uses “off the shelf” end-to-end traffic generators
  - Bidirectional “on-PON” monitor enables:
    - Isolation of performance issues
    - Interoperability testing of MPCP and OAM protocols
    - Tests alignment of data packets to transmit windows

# 10G EPON Option 1 Performance Analysis

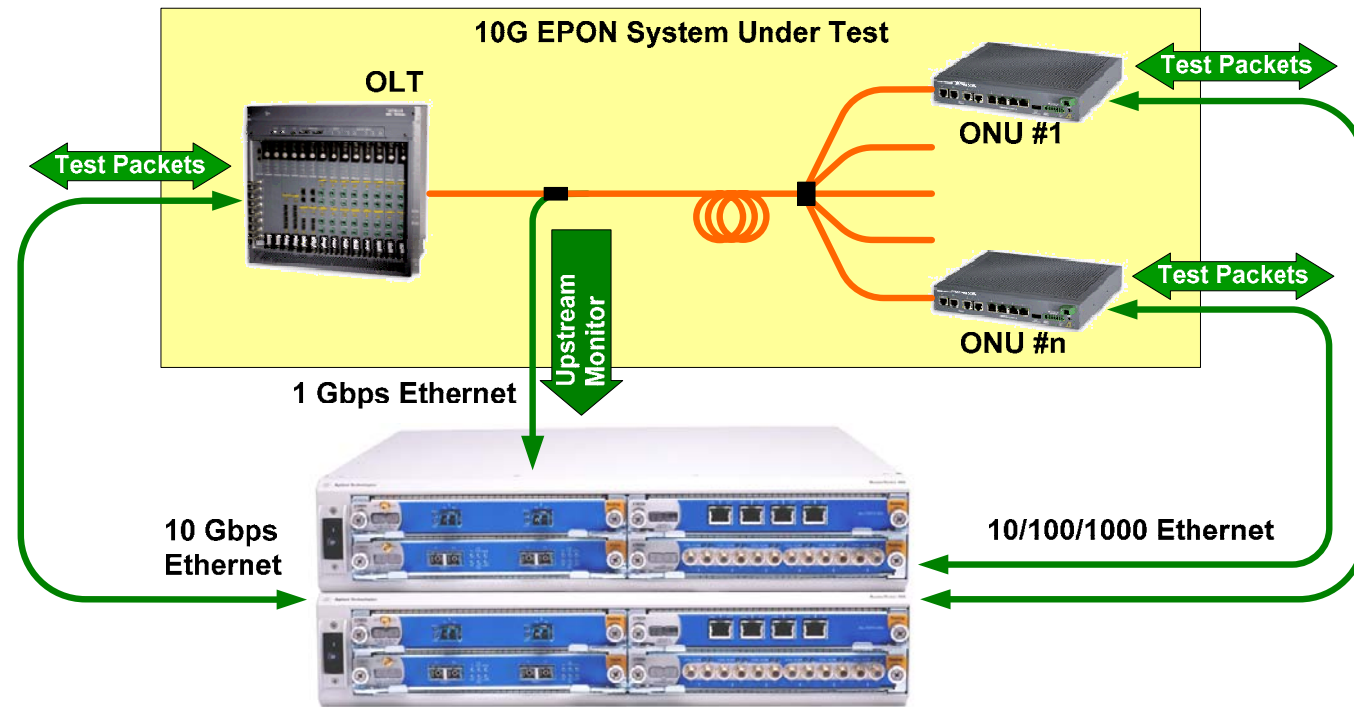

- **A 10G EPON Option 1 (10 Gbps downstream, 1 Gbps upstream) Performance Analysis System is possible today,** assuming no changes to the upstream mechanism from today
  - Performs end-to-end testing;
  - Performance measurements;
  - Analysis of the upstream portions of OAM & MPCP.

# 10G EPON Option 2 Performance Analysis

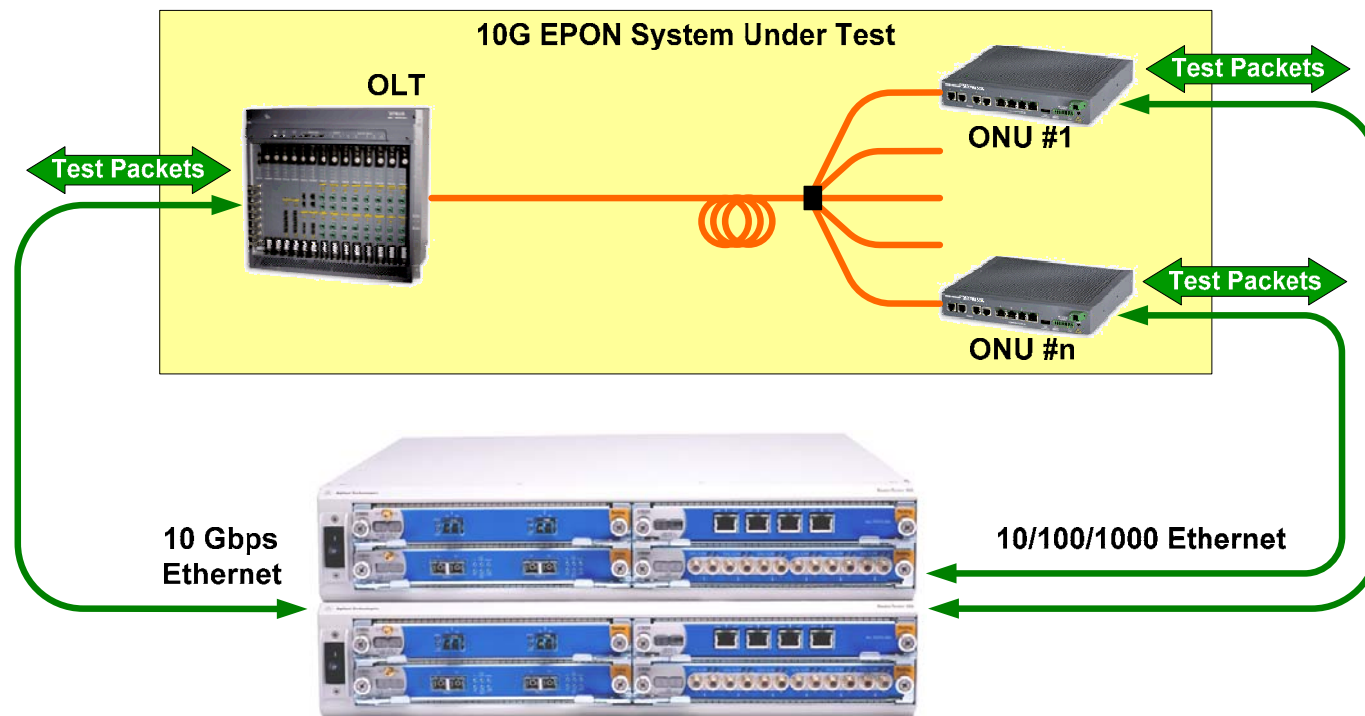

- **A 10G EPON Option 2 (10 Gbps downstream, 10 Gbps upstream)** can be tested end-to-end **today** with available 1G and 10G traffic generators;
  - Can measure the end-to-end service capability;
  - Can measure performance of a 10G EPON;
  - Would require the future development of a 10G EPON monitor capability.

# EPON is 10G-ible

[tangi ble]

---

Summary and Straw Polls

# Summary

---

1

- EPON is successfully deployed in volume
- The market demands a faster EPON

2

- If IEEE 802.3 does not define a higher-speed EPON, carriers may migrate to non-IEEE PON solutions.

3

- 10 Gbps EPON is technically feasible
  - **Demos by ETRI and KDDI**
- We need to define a PHY for 10 Gbps EPON
  - **consistent with IEEE 802.3 line rate progression**  
10M → 100M → 1G → 10G → ...

# Straw Polls

---

163 Number of people in the room

58 Individuals would attend and contribute to the **10 Gbps PHY for EPON Study Group**

31 Companies Support the Formation of the **10 Gbps PHY for EPON Study Group**

# Polls

---

- Request that IEEE 802.3 WG form a study group to develop a PAR & 5 Criteria for 10 Gbps PHY for EPON

– Y: 84

– N: 10

– A: 23