

## RS Sleep Mode

### IEEE 802.16 Presentation Submission Template (Rev. 8.3)

Document Number:

IEEE S802.16j-07/066

Date Submitted:

2007-01-08

Source:

Kanchei (Ken) Loa, Hua-Chiang Yin,  
Yi-Hsueh Tsai, Shiann Tsong Sheu,  
Yung-Ting Lee, Youn-Tai Lee,  
Frank C.D. Tsai, Heng-Iang Hsu,  
Chih-Chiang Hsieh, Tien-Hsiang Lo  
Institute for Information Industry  
8F, No. 218, Sec. 2, Dunhua S. Rd.,  
Taipei City 106, Taiwan, ROC.

Voice: +886-2-27399616

Fax: +886-2-23782328

E-mail: loa@nmi.iii.org.tw

Venue:

IEEE 802.16 Session #47, London, UK

Base Document:

C80216j-07\_066

Purpose:

This contribution proposes RS sleep mode procedure and restrictions.

Notice:

This document has been prepared to assist IEEE 802.16. It is offered as a basis for discussion and is not binding on the contributing individual(s) or organization(s). The material in this document is subject to change in form and content after further study. The contributor(s) reserve(s) the right to add, amend or withdraw material contained herein.

Release:

The contributor grants a free, irrevocable license to the IEEE to incorporate material contained in this contribution, and any modifications thereof, in the creation of an IEEE Standards publication; to copyright in the IEEE's name any IEEE Standards publication even though it may include portions of this contribution; and at the IEEE's sole discretion to permit others to reproduce in whole or in part the resulting IEEE Standards publication. The contributor also acknowledges and accepts that this contribution may be made public by IEEE 802.16.

IEEE 802.16 Patent Policy:

The contributor is familiar with the IEEE 802.16 Patent Policy and Procedures <<http://ieee802.org/16/ipr/patents/policy.html>>, including the statement "IEEE standards may include the known use of patent(s), including patent applications, provided the IEEE receives assurance from the patent holder or applicant with respect to patents essential for compliance with both mandatory and optional portions of the standard." Early disclosure to the Working Group of patent information that might be relevant to the standard is essential to reduce the possibility for delays in the development process and increase the likelihood that the draft publication will be approved for publication. Please notify the Chair <<mailto:chair@wirelessman.org>> as early as possible, in written or electronic form, if patented technology (or technology under patent application) might be incorporated into a draft standard being developed within the IEEE 802.16 Working Group. The Chair will disclose this notification via the IEEE 802.16 web site <<http://ieee802.org/16/ipr/patents/notices>>.

# Introduction

- Sleep mode defined in IEEE 802.16e-2005 is essential for conserving power and radio resources on access link
- This contribution discusses the RS Sleep Mode for conserving RS power, and radio resources on access link and relay link

## Requirements for RS Sleep Mode

- For mobile RS
  - Mobile RS powered by battery
- For fixed/nomadic RS
  - RS without power wire connection
    - e.g., RS relying on solar power as primary or backup power source
  - RS with power wire connection
    - e.g., RS operating with the battery-powered UPS when power fails
  - For eco-awareness reason

# Design Objectives

1. Support of RS sleep mode is **optional**
2. Support of RS sleep mode **shall** not need any change on MS
3. RS sleep mode **shall** be centralized controlled at MR-BS in MR networks with centralized scheduling or distributed scheduling
4. RS sleep mode **should** support MS event-based actions (e.g., MOB\_SCN-REQ / MOB\_SCN-REP / MOB\_MSHO-REQ).
5. RS sleep mode **should** support MS mobility and MS network entry/re-entry/handover
6. RS sleep mode **should** support various RS deployment scenarios

## Design Considerations

- The trigger methods of RS sleep mode shall be initiated by either RS itself or MR-BS
- The trigger methods of MS sleep mode are still initiated by either MS or MR-BS as defined in IEEE 802.16e-2005

# Principles of Centralized Control

- MR-BS is responsible for controlling RS sleep mode
- MR-BS and MS exchange MS sleep mode messages end-to-end and RS shall have the associated information

# RS Sleep Mode

- RS could get into sleep mode only when all subordinated MSs and RSs are in sleep mode
- RS sleep mechanism:
  - RS can request the activation of RS sleep mode by exchanging RS\_SLP-REQ/RS\_SLP-RSP messages with MR-BS
  - Alternatively, RS sleep mode is activated by MR-BS by sending unsolicited RS\_SLP-RSP to designated RS
  - RS is notified sleep information of all subordinate MSs and RSs by MR-BS
  - The RS sleep window shall be less than or equal to the overlapping time interval of all sleep windows of connections of subordinate MS(s) and RS(s)
- RS wake up mechanism:
  - The RS can wake up via the notification of MOB\_TRF-IND sent by the MR-BS
  - The RS can also wake up by itself when it wants to send data to the MR-BS

# RS Sleep Mode Initiation

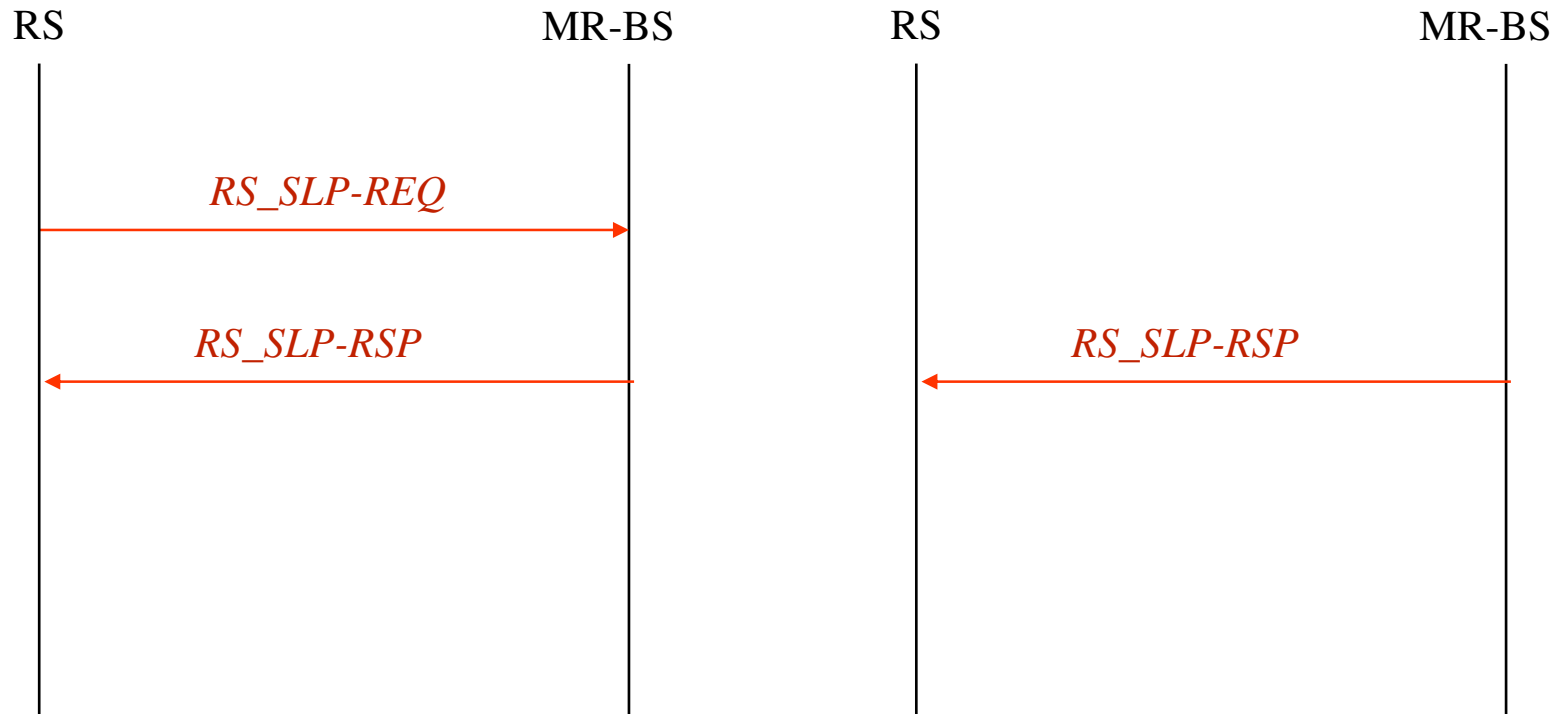

*RS-initiated*

*MR-BS-initiated*

## Types of RS Sleep Mode

- Full RS Sleep Mode
  - No traffic at relay link and access link
- Partial RS Sleep Mode
  - No traffic at relay link or access link except the DL Start Frame Preamble, FCH, DCD, UCD, DL\_MAP, UL\_MAP, broadcast messages, etc., sent by RS at predefined intervals
  - When the RS supports its subordinate MS event-based actions, it shall send the DL Start Frame Preamble, FCH and UL\_MAP, and allocate UL BW for bandwidth requests. In addition, the interval between two consecutive UL BW allocations shall be less than the lost UL-MAP Interval defined in IEEE 802.16-2004
  - RS in Partial RS Sleep Mode may
    - Send its own broadcast messages
    - Relay broadcast messages from MR-BS

# Examples of Full RS Sleep Mode

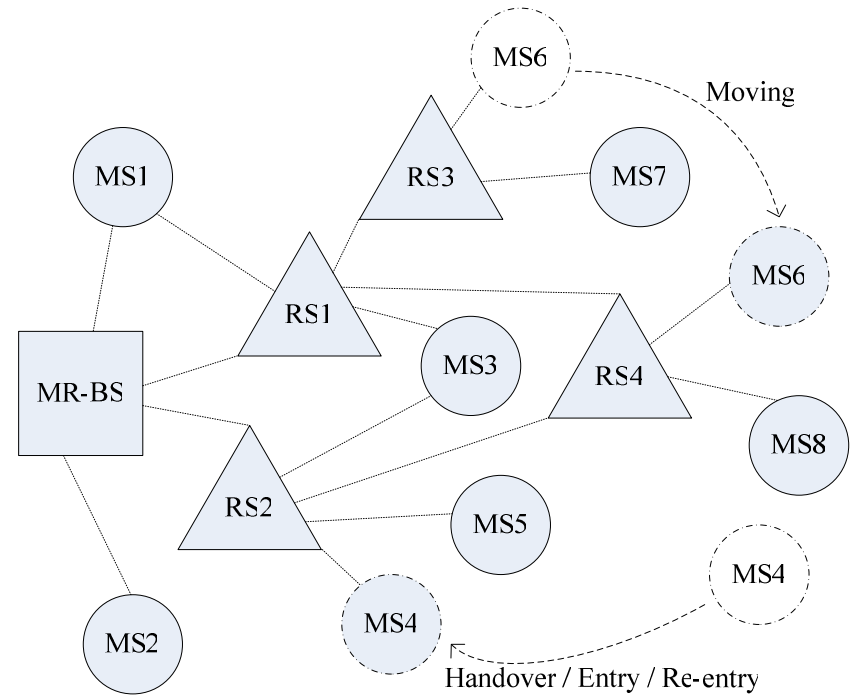

Ex 1:

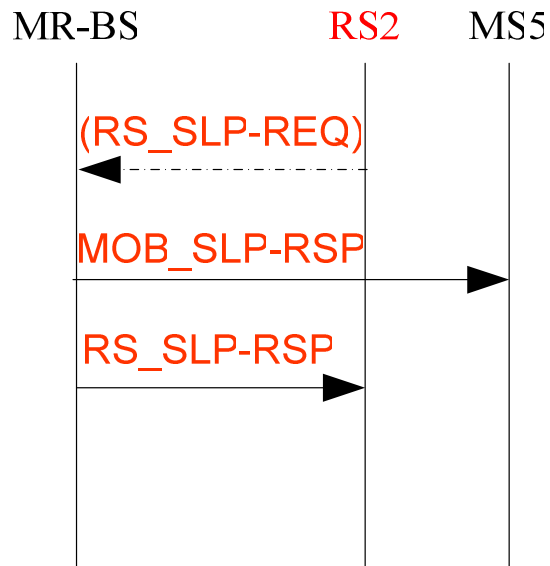

Ex 2:

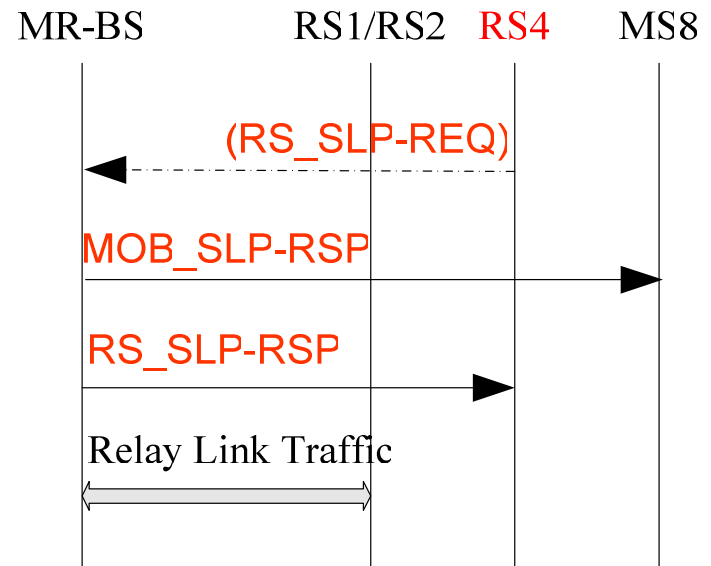

# Examples of Partial RS Sleep Mode

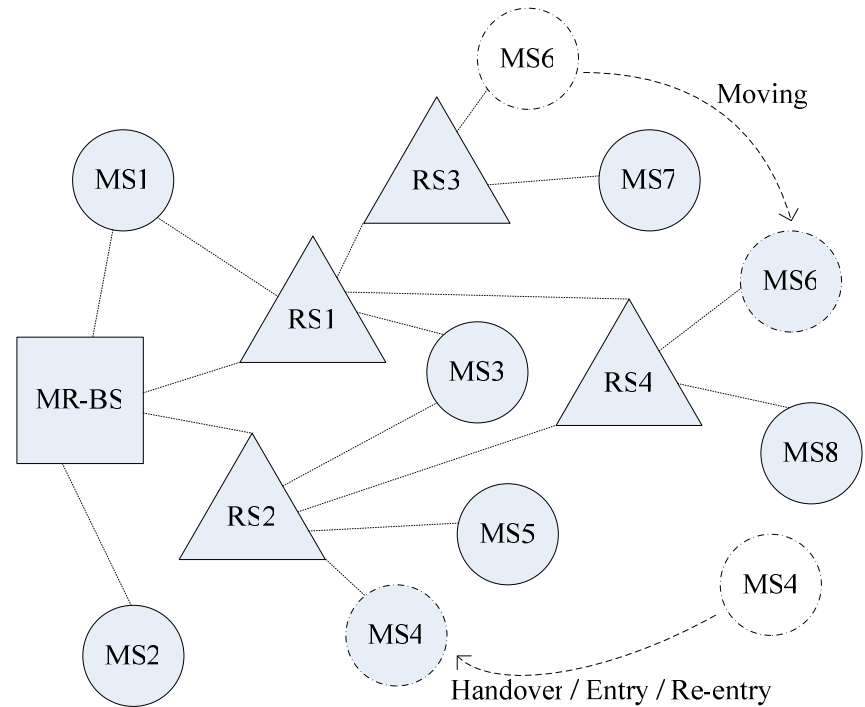

Ex1:

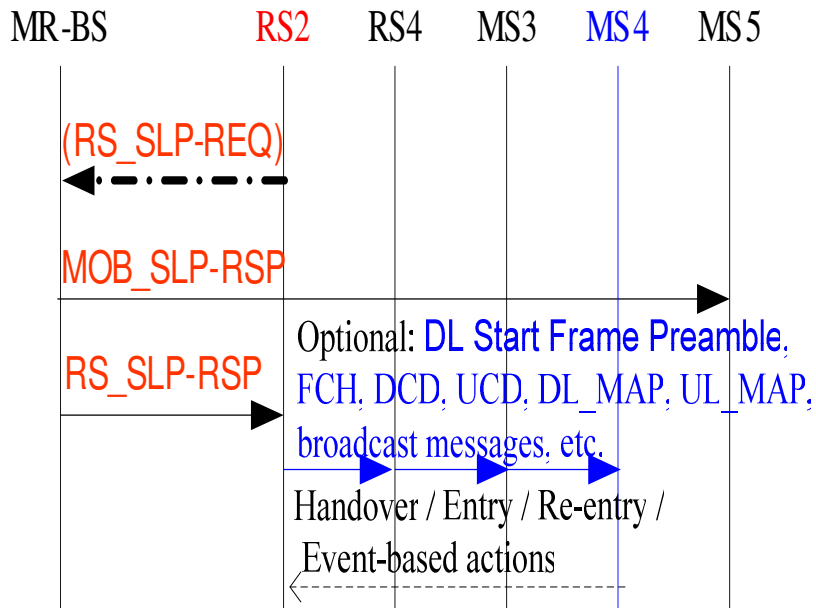

Ex2:

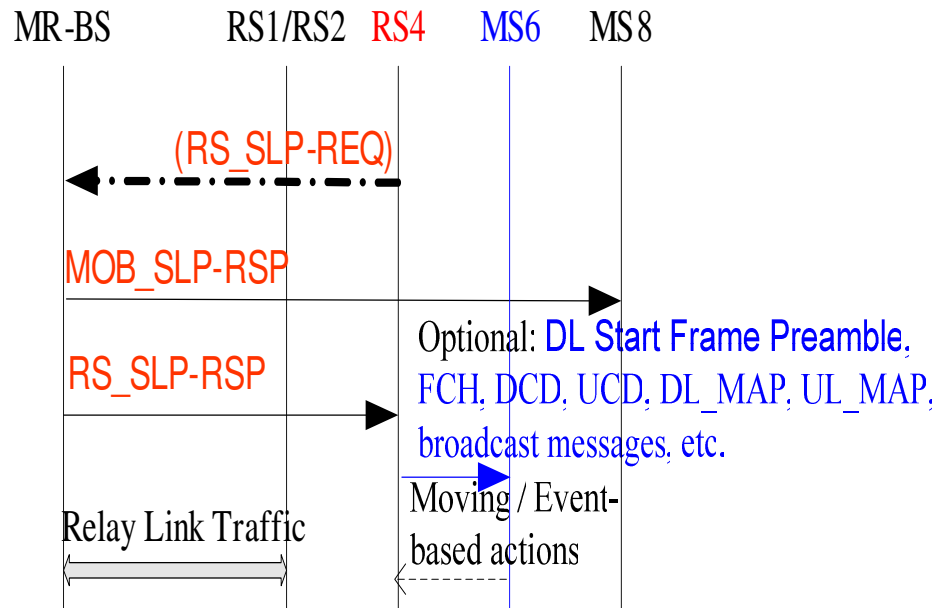

## Conclusions

- Propose procedures for RS sleep mode
  - Full and partial RS sleep mode procedures
  - **RS\_SLP-REQ/RSP** management messages between MR-BS and RS to support RS sleep mode
- The partial RS sleep mode is proposed to support MS event-based actions such as MS mobility, MS network entry/re-entry, etc

# Example MSC of RS sleep mode initiated by RS

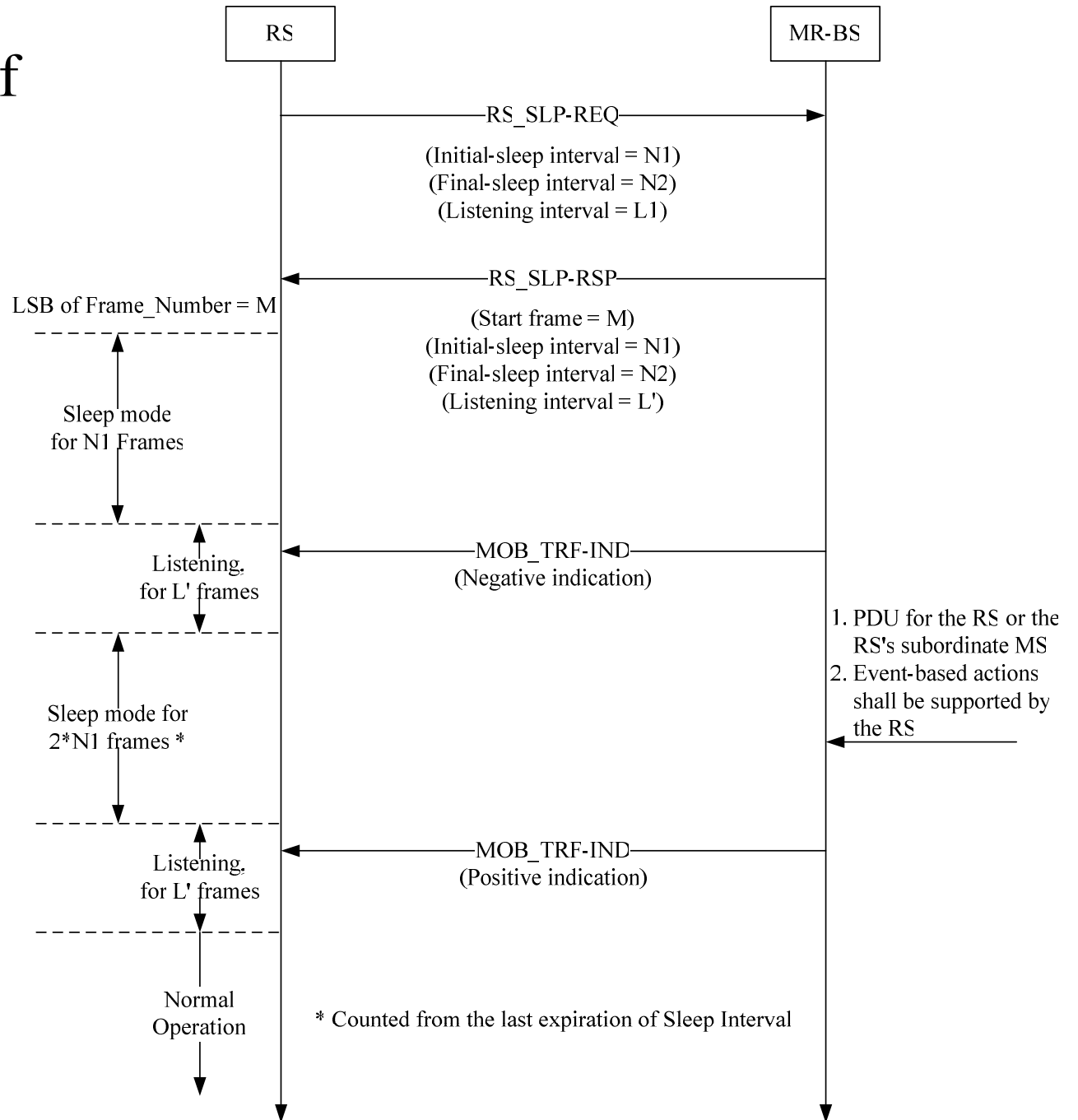

# Example MSC of RS sleep mode initiated by MR-BS

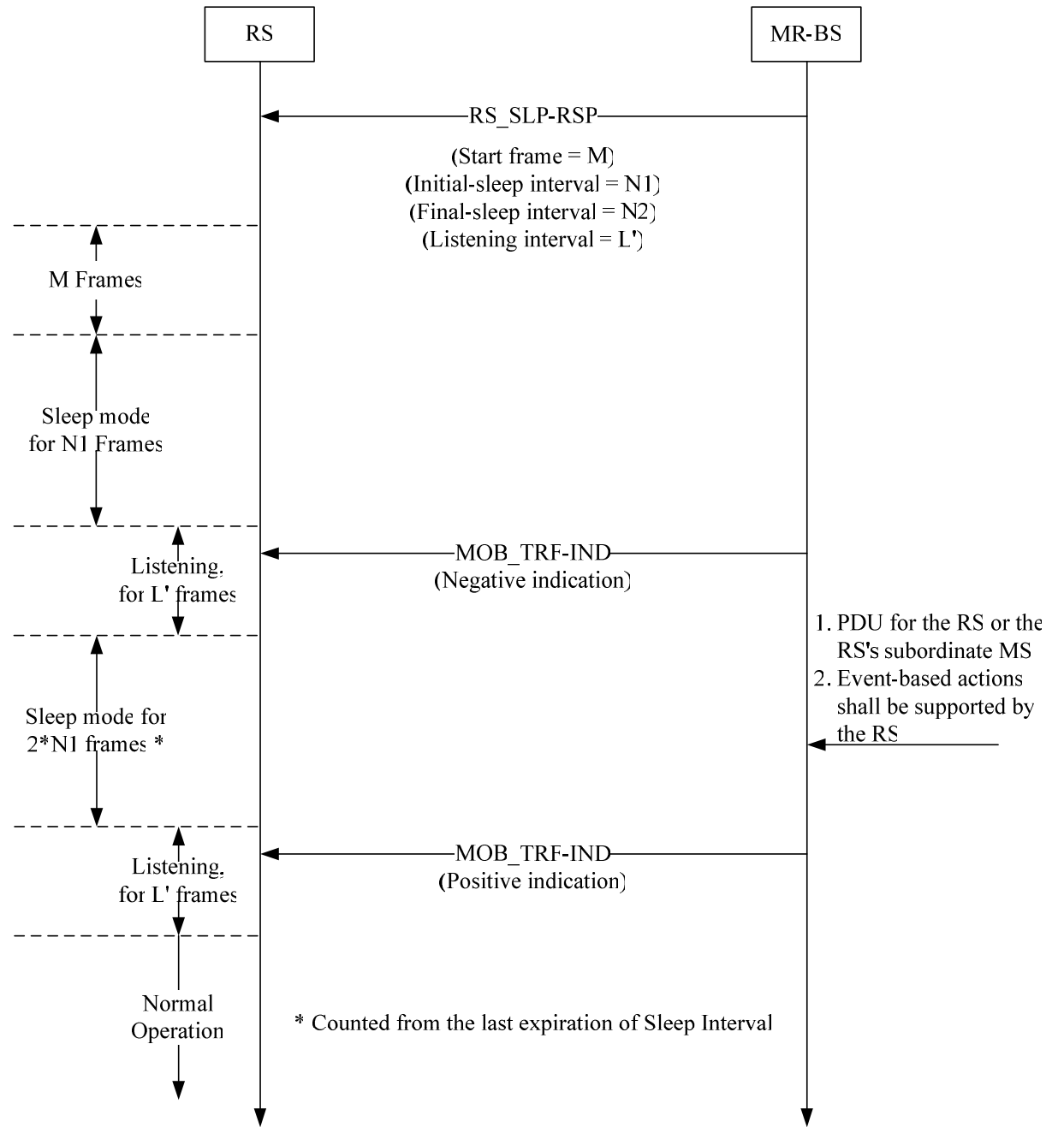

# Example MSC of RS awakening initiated by RS

