

Project	IEEE 802.16 Broadband Wireless Access Working Group < http://ieee802.org/16 >	
Title	Complementary document for draft comments	
Date Submitted	2003-10-31	
Source(s)	<p>Yossi Segal Itzik Kitroser Yigal Leiba Zion Hadad Runcom Technologies Ltd. 2 Hachoma St. 75655 Rishon Lezion, Israel</p>	<p>Voice: +972-3-9528440 Fax: +972-3-9528805 yossis@runcom.co.il itzikk@runcom.co.il yigall@runcom.co.il zionh@runcom.co.il</p>
	<p>Avi Freedman Hexagon System Engineering 21c Yegi'a Kapa'im st. P.O. Box 10149 Petach Tikva, 49001 Israel</p>	<p>Voice: +972-3-9224420 Fax: +972-3-9224396 avi@hexagonltd.com</p>
Re:	Contribution elaborating on comments for letter ballot #13	
Abstract	This document includes text referenced in several comments given for ballot 13	
Purpose	To be integrated into P80216-REVd_D1 document	
Notice	This document has been prepared to assist IEEE 802.16. It is offered as a basis for discussion and is not binding on the contributing individual(s) or organization(s). The material in this document is subject to change in form and content after further study. The contributor(s) reserve(s) the right to add, amend or withdraw material contained herein.	
Release	The contributor grants a free, irrevocable license to the IEEE to incorporate material contained in this contribution, and any modifications thereof, in the creation of an IEEE Standards publication; to copyright in the IEEE's name any IEEE Standards publication even though it may include portions of this contribution; and at the IEEE's sole discretion to permit others to reproduce in whole or in part the resulting IEEE Standards publication. The contributor also acknowledges and accepts that this contribution may be made public by IEEE 802.16.	
Patent Policy and Procedures	The contributor is familiar with the IEEE 802.16 Patent Policy and Procedures < http://ieee802.org/16/ipr/patents/policy.html >, including the statement "IEEE standards may include the known use of patent(s), including patent applications, provided the IEEE receives assurance from the patent holder or applicant with respect to patents essential for compliance with both mandatory and optional portions of the standard." Early disclosure to the Working Group of patent information that might be relevant to the standard is essential to reduce the possibility for delays in the development process and increase the likelihood that the draft publication will be approved for publication. Please notify the Chair < mailto:chair@wirelessman.org > as early as possible, in written or electronic form, if patented technology (or technology under patent application) might be incorporated into a draft standard being developed within the IEEE 802.16 Working Group. The Chair will disclose this notification via the IEEE 802.16 web site < http://ieee802.org/16/ipr/patents/notices >.	

Complementary document for ballot 13 comments

Yossi Segal
Yigal Leiba
Itzik Kitroser
Zion Hadad
Runcom

Avi Freedman
Hexagon

1 Introduction

The following contribution contains the relevant information that should be changed in the appropriate sections. This document is referenced by several comments.

8.5.4.5 Allocation of sub-channels for FCH, and logical sub-channel numbering

	Physical Enumeration	Logical Enumeration (Renumbered)
	SC 10	SC 31
FCH	SC 11	SC 0
	SC 12	SC 1
	SC 13	SC 2
	SC 14	SC 3
Repetition Coding 1	SC 15	SC 4
	SC 16	SC 5
	SC 17	SC 6
Repetition Coding 2	SC 18	SC 7
	SC 19	SC 8
	SC 20	SC 9
Repetition Coding 3	SC 21	SC 10
	SC 22	SC 11
	SC 23	SC 12

Figure 227a—DL Frame Prefix sub-channel allocation for segment 1 using FUSC

8.5.6.1.1 Preamble

The PN series modulating the pilots is defined in Table 227a, the series modulated depends on the Sector and the Preamble type (PNId), and the defined series shall be mapped onto the preamble carriers in an ascending order:

Number	CellId	Segment	Series to modulate (W_k)	Boostng	PAPR	Usage
0	0	0		5/4		PUSC
1	0	0		5/4		PUSC
2	0	0		5/4		PUSC
3	0	0		5/4		PUSC
4	0	1		5/4		PUSC
5	0	1		5/4		PUSC
6	0	1		5/4		PUSC
7	0	1		5/4		PUSC
8	0	2		5/4		PUSC
9	0	2		5/4		PUSC
10	0	2		5/4		PUSC
11	0	2		5/4		PUSC
12	0	0		3		FUSC
13	1	0		3		FUSC
14	2	0		3		FUSC
15	3	0		3		FUSC
16	4	0		3		FUSC
17	5	0		3		FUSC
18	6	0		3		FUSC
19	7	0		3		FUSC
20	8	0		3		FUSC
21	9	0		3		FUSC
22	10	0		3		FUSC
23	11	0		3		FUSC
24	12	1		3		FUSC
25	13	1		3		FUSC
26	14	1		3		FUSC
27	15	1		3		FUSC
28	16	1		3		FUSC
29	17	1		3		FUSC
30	18	1		3		FUSC
31	19	1		3		FUSC
32	20	1		3		FUSC
33	21	1		3		FUSC
34	22	2		3		FUSC
35	23	2		3		FUSC
36	24	2		3		FUSC
37	25	2		3		FUSC
38	26	2		3		FUSC
39	27	2		3		FUSC
40	28	2		3		FUSC
41	29	2		3		FUSC
42	30	2		3		FUSC
43	31	2		3		FUSC

8.5.6.1.2 Symbol Structure

Table 246—OFDMA downlink carrier allocations

Parameter	Value	Comments
Number of DC Carriers	1	Index 1024
Number of Guard Carriers, Left	172	
Number of Guard Carriers, Right	172	
Number of Used Carriers (N_{used})	1703	Number of all carriers used within a symbol, including all <u>possible</u> allocated pilots for each segment.
Pilots		
VariableSet#0	24	0,72,144,216,288,360,432,504,576,648,720,792,864,936,1008,1080,1152,,1224,1296,1368,1440,1512,1584,1656
ConstantSet#0	4	39,645,1017,1407
VariableSet#1	24	36,108,180,252,324,396,468,540,612,684,756,828,900,972,1044,1116,1188,1260,1332,1404,1476,1548,1620,1692
ConstantSet#1	4	261,,651,1143,1419
VariableSet#2	23	48,120,192,264,336,408,480,552,624,696,768,840,912,984,1056,1128,1200,1272,1344,1416,1488,1560,1632
ConstantSet#2	4	330,726,1155,1461
VariableSet#3	24	12,84,156,228,300,372,444,516,588,660,732,804,876,948,1020,1092,1164,1236,1308,1380,1452,1524,1596,1668
ConstantSet#3	4	342,849,1158,1530
VariableSet#4	24	24,96,168,240,312,384,456,528,600,672,744,816,888,960,1032,1104,1176,1248,1320,1392,1464,1536,1608,1680
ConstantSet#4	4	351,855,1185,1545
VariableSet#5	23	60,132,204,276,348,420,492,564,636,,708,780,852,924,996,1068,1140,1212,1284,1356,1428,1500,1572,1644
ConstantSet#5	4	522,918,1206,1701
Number of data carriers	1536	
Number of data carriers per sub-channel	48	
Number of Sub-Channels	32	
PermutationBase ₀		{3, 18, 2, 8, 16, 10, 11, 15, 26, 22, 6, 9, 27, 20, 25, 1, 29, 7, 21, 5, 28, 31, 23, 17, 4, 24, 0, 13, 12, 19, 14, 30}

Table 246a specifies the pilot sets and actual pilot index used for different transmissions (using Segment X ranging from 0..2)

Transmission	Variable Pilots Set used	Shift indices of variable pilots set by	Constant pilot set used	Remarks
PUSC Segment#X	$(2 * \text{SymbolNumber} + 2 * X) \bmod 6$ $(2 * \text{SymbolNumber} + 2 * X + 1) \bmod 6$	0 3	X	In FDD mode no discontinuity of the pilot set rotation is allowed

FUSC Segment#X	All sets	$(4 * \text{SymbolNumber}) \bmod 12$	All Sets	
----------------	----------	--------------------------------------	----------	--

8.5.9 Channel coding

Channel coding procedures include randomization (see 8.5.9.1), FEC encoding (see 8.5.9.2), bit interleaving (see 8.5.9.3) modulation (see 8.5.9.4) and symbol interleaving (8.5.9.5).

When repetition code is used, allocation for the transmission shall always include an even number of adjacent Sub-Channels. The basic block shall pass the regular coding chain where the first Sub-Channel shall set the randomization seed used in section 8.5.9.1, and the data shall follow the coding chain up to the Mapping. The data outputted from the modulation (section 8.5.9.4) shall be mapped onto the block of sub-channels allocated for the basic block and then it will be also mapped on the following consecutive allocated Sub-Channels (for repetition coding of 2 another block of sub-channels of the same size is used, while for repetition coding of 4 another 3 blocks of sub-channels of the same size are used), the process of regular encoding and repetition encoding is shown in figure 246a

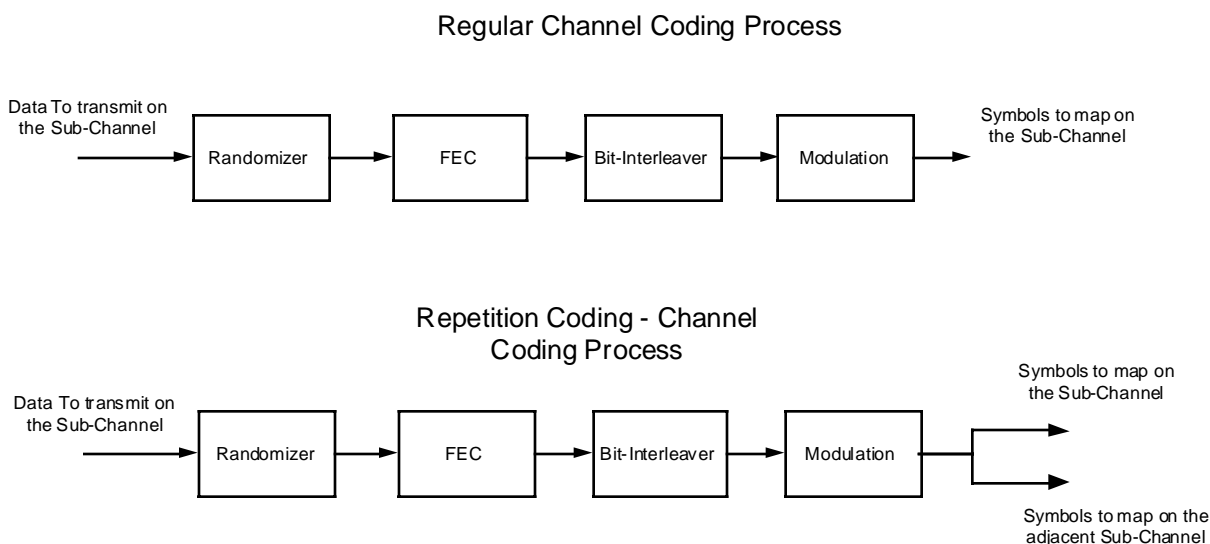

Figure 246a— Channel Coding Process for regular and repetition coding transmission

8.5.8.4.2 Symbol Structure

The same symbol structure defined in sections 8.5.6.1.1 and 8.5.6.1.2 shall apply for the STC mode, the pilots allocated to each antenna and their details are specified in table Z which specifies the pilot sets and actual pilot index used for different transmissions (using Segment X ranging from 0..2)

Transmission		Variable Pilots Set used	Shift indices of variable pilots set by	Constant pilot set used	Remarks
PUSC Segment#X	Antenna 0	$(2 * \text{SymbolNumber} + 2 * X) \bmod 6$	0	X	In FDD mode no discontinuity of the pilot set rotation is allowed
	Antenna 1	$(2 * \text{SymbolNumber} + 2 * X + 1) \bmod 6$	0	X+1	
FUSC Segment#X	Antenna 0	0,2,4	$(4 * \text{SymbolNumber}) \bmod 12$	0,2,4	

	Antenna 1	1,3,5	$(4 * \text{SymbolNumber}) \bmod 12$	1,3,5	
--	-----------	-------	--------------------------------------	-------	--