

# Stressed Eye and TDP test update – April 8, 2002

**Objective: Test the tests**

Stretch Camnitz- LightWave Division  
Agilent Technologies Test Equipment Group  
stretch\_camnitz@agilent.com

# Receiver Test

- Simplified Stress
- PRBS31

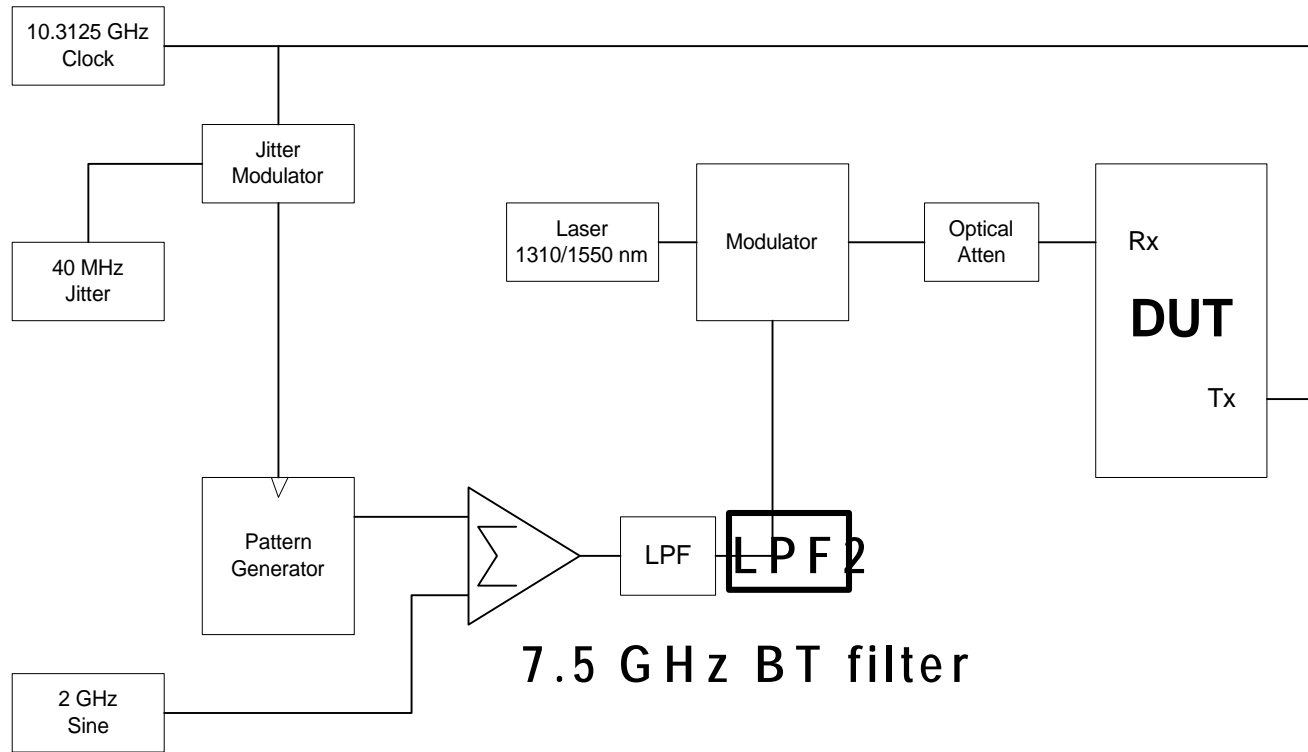

# Averaged Waveform Measurement- 2x 7.5 GHz BT Filters

PR

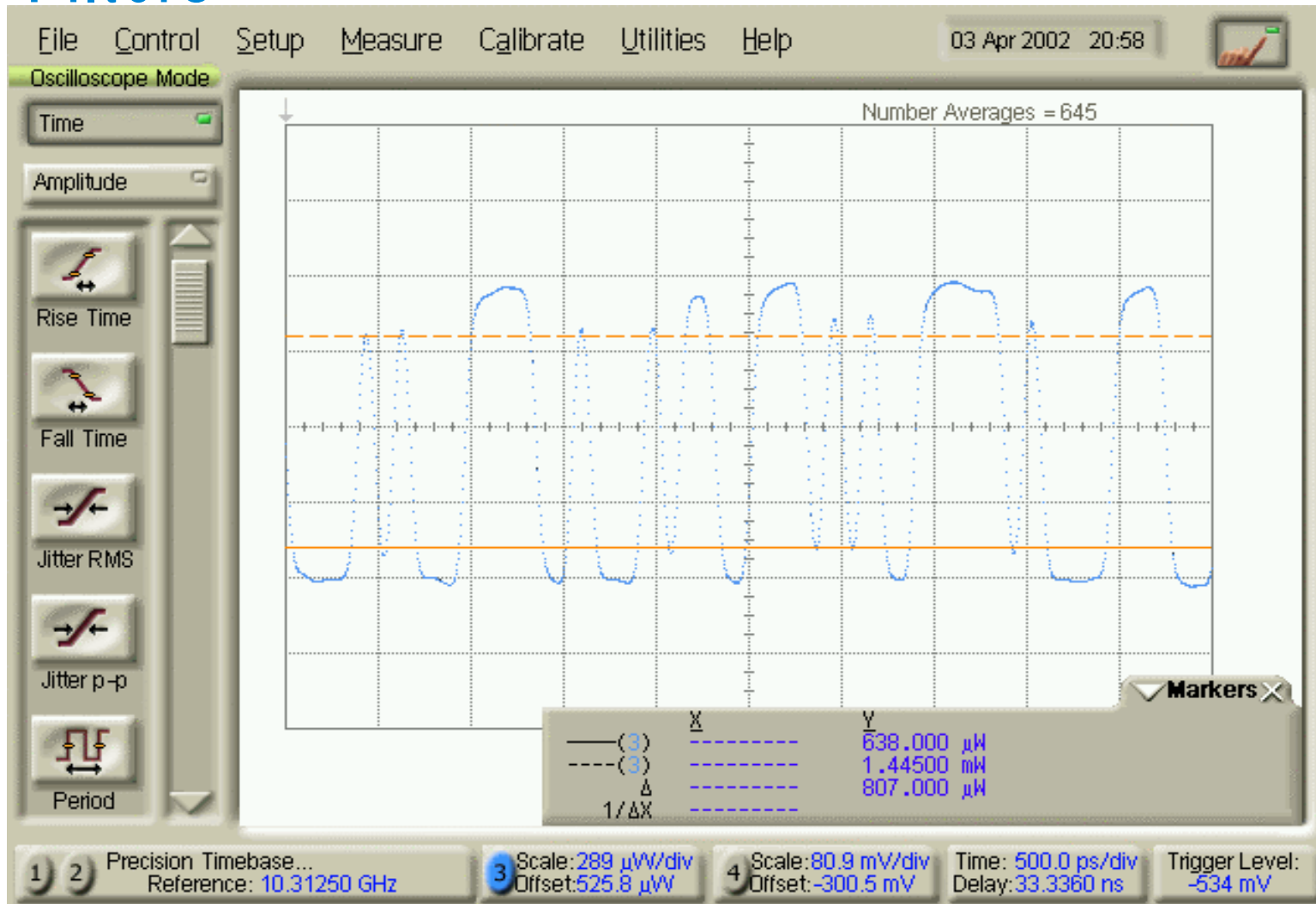

# Eye Measurement- 2x 7.5 GHz BT Filters only

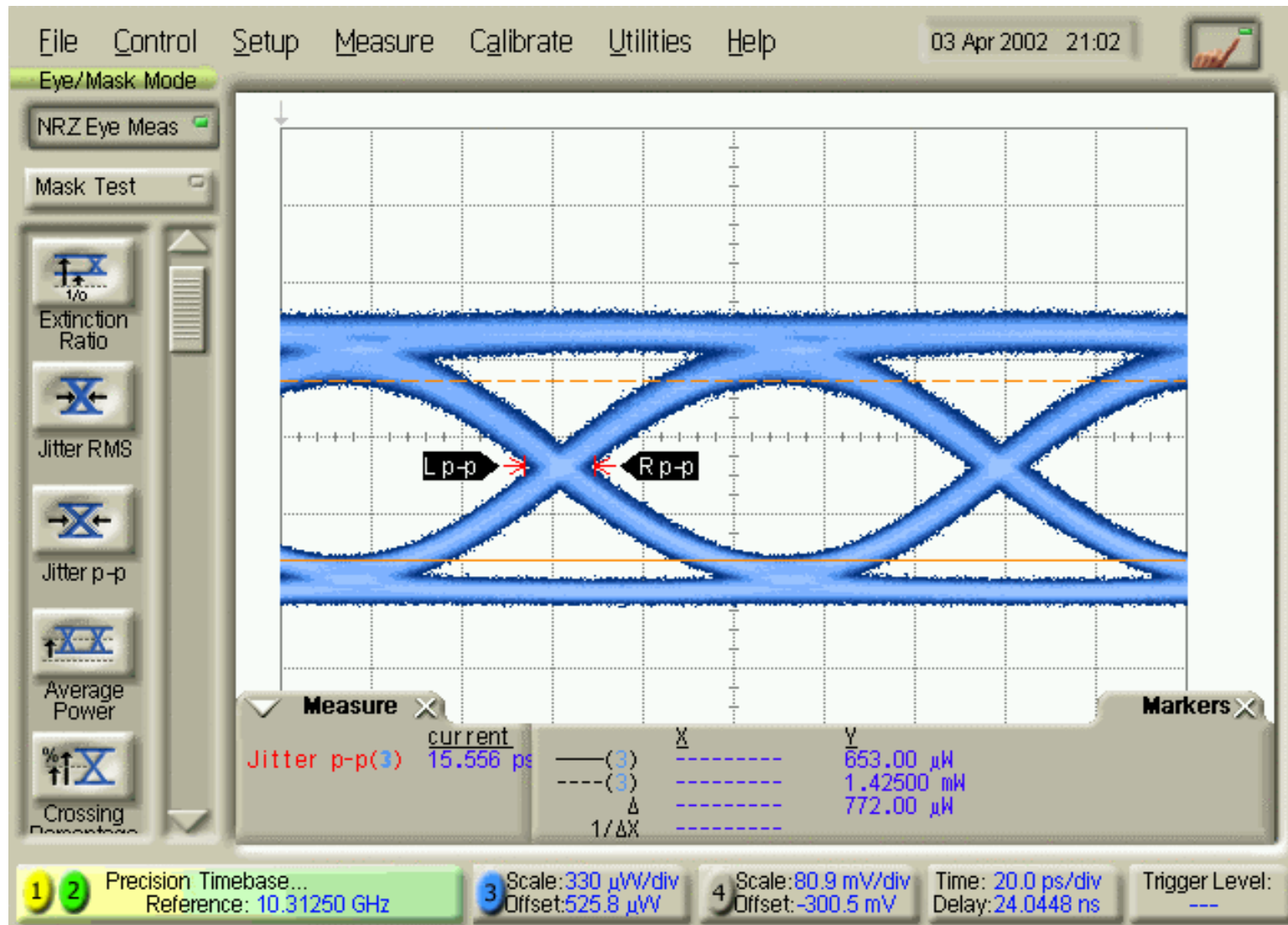

# Sinusoidal 40 MHz Clock Jitter vs Clean Ref Clock

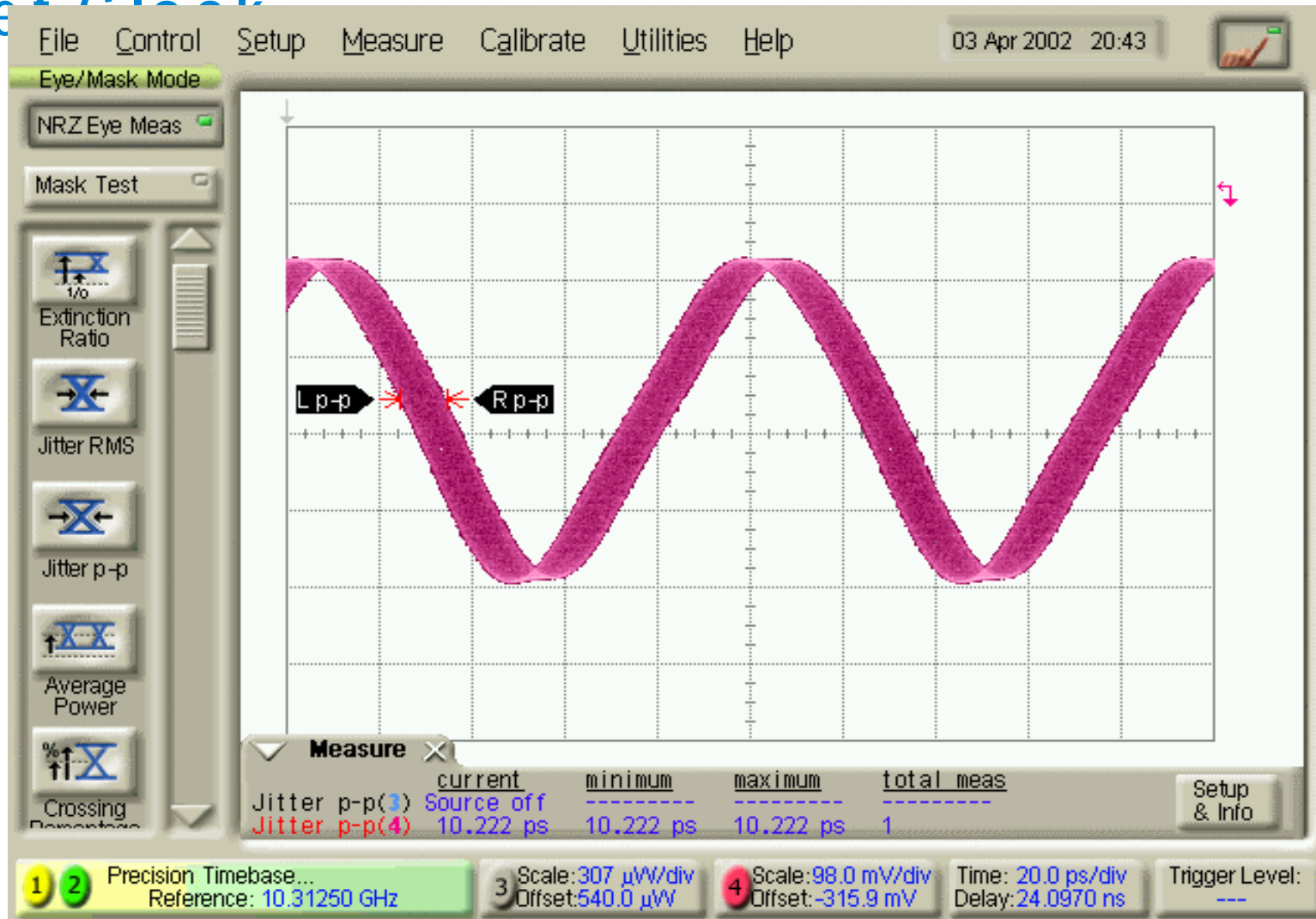

# Amplitude Interferer Measurement- by Averaging

add

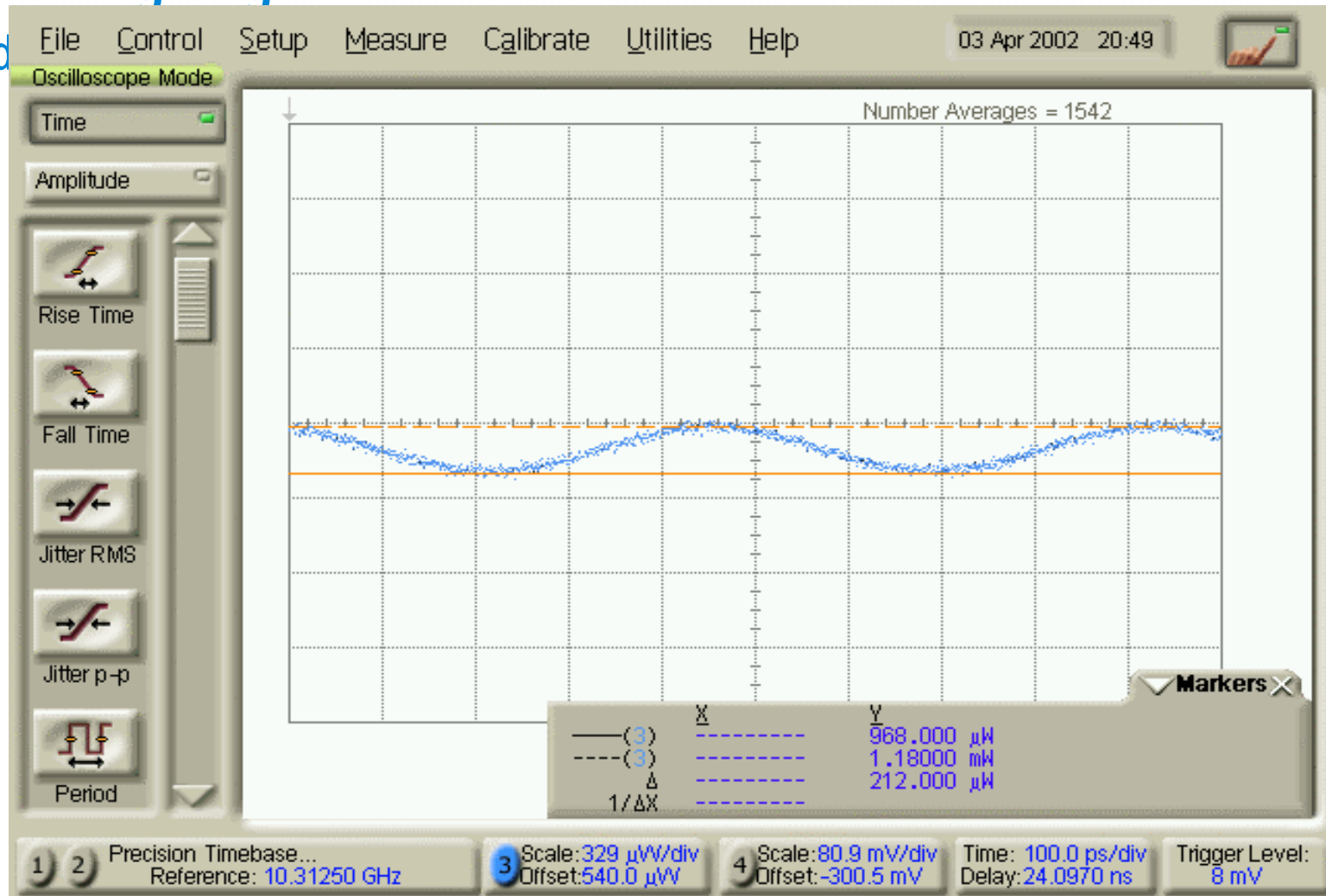

# Complete Stress signal with SJ and AM - 3dB VECP

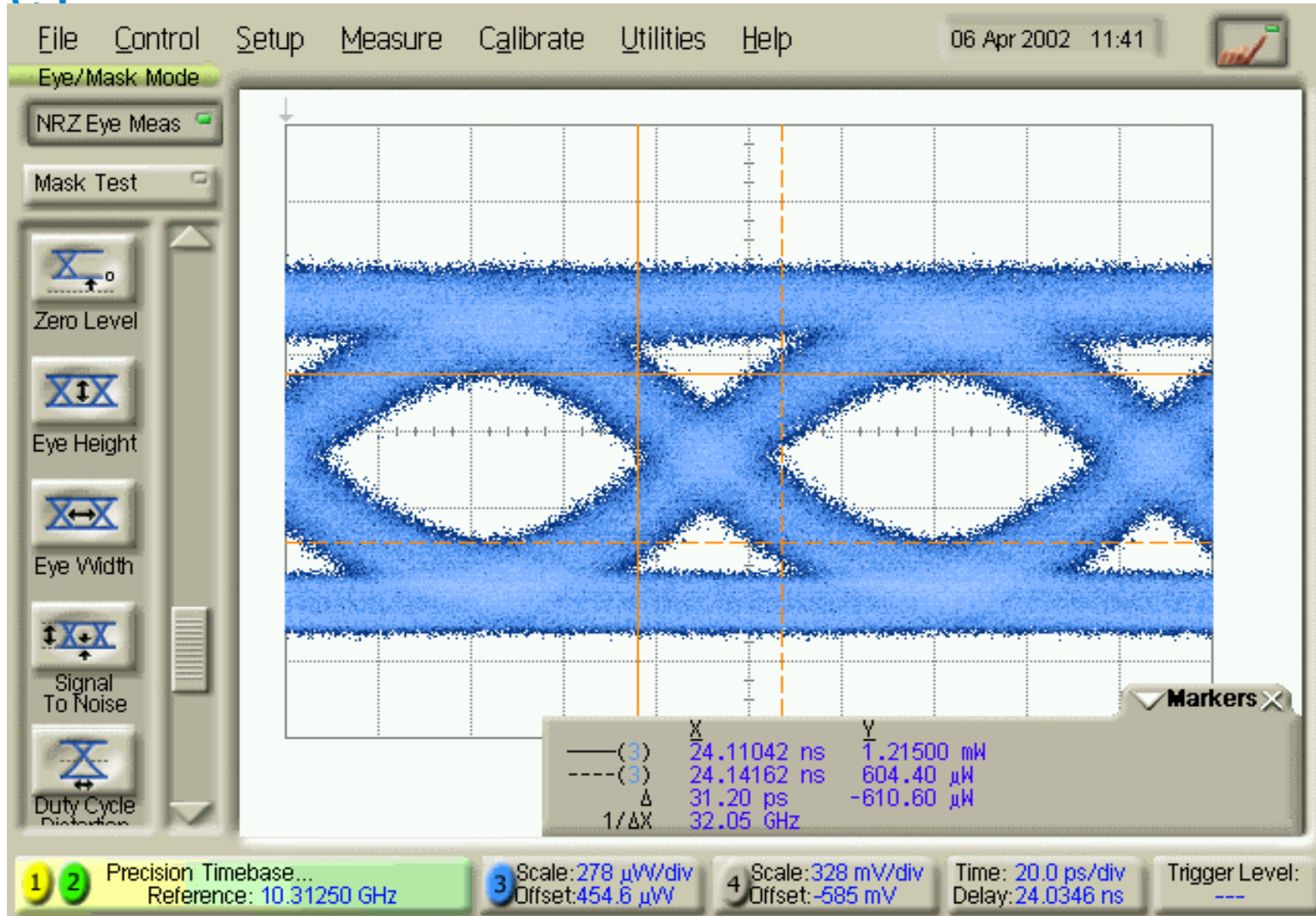

# PRBS31

10GBE Bathtub Curve with Limit Mask

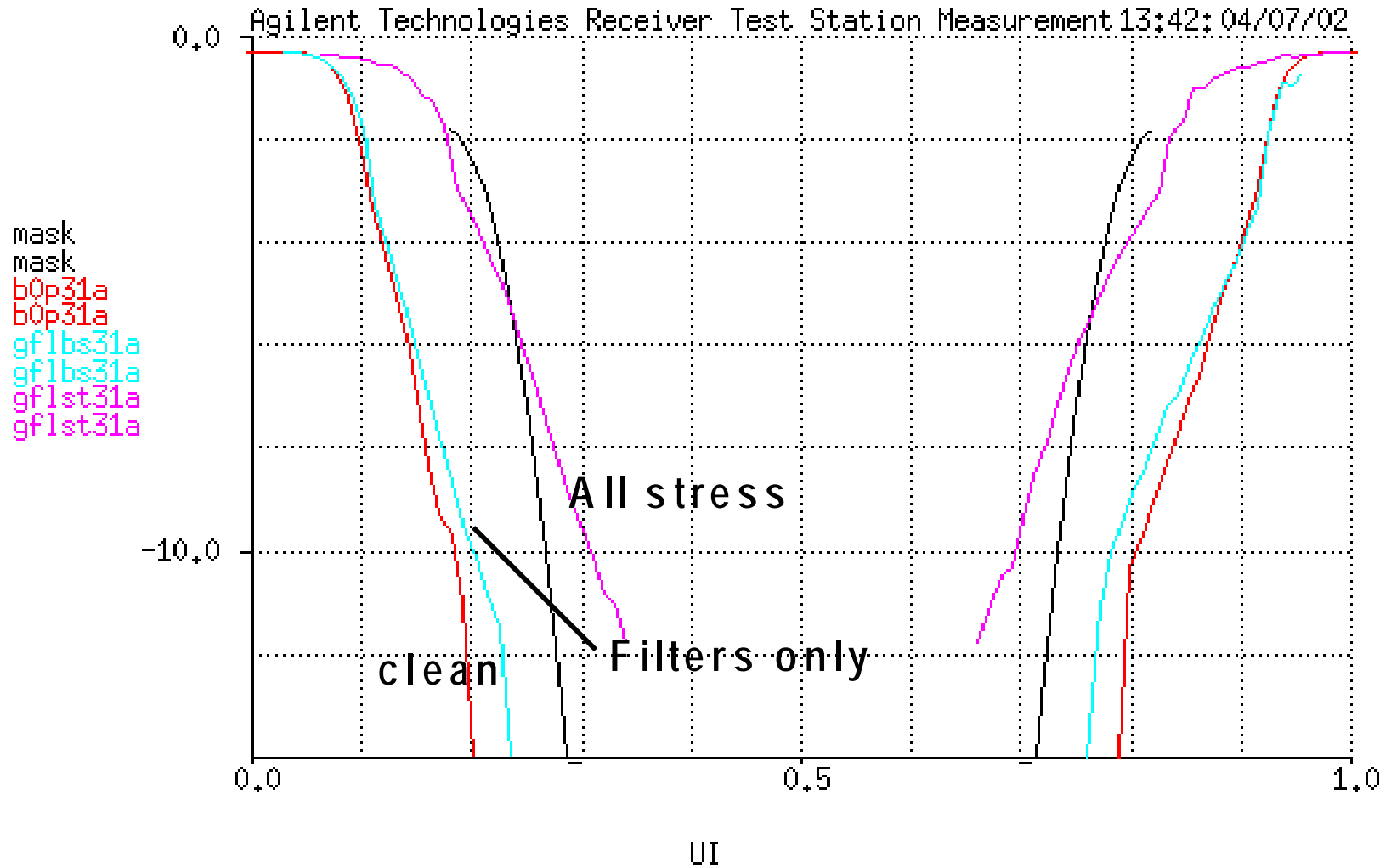

# All Stress

10GBE Bathtub Curve with Limit Mask

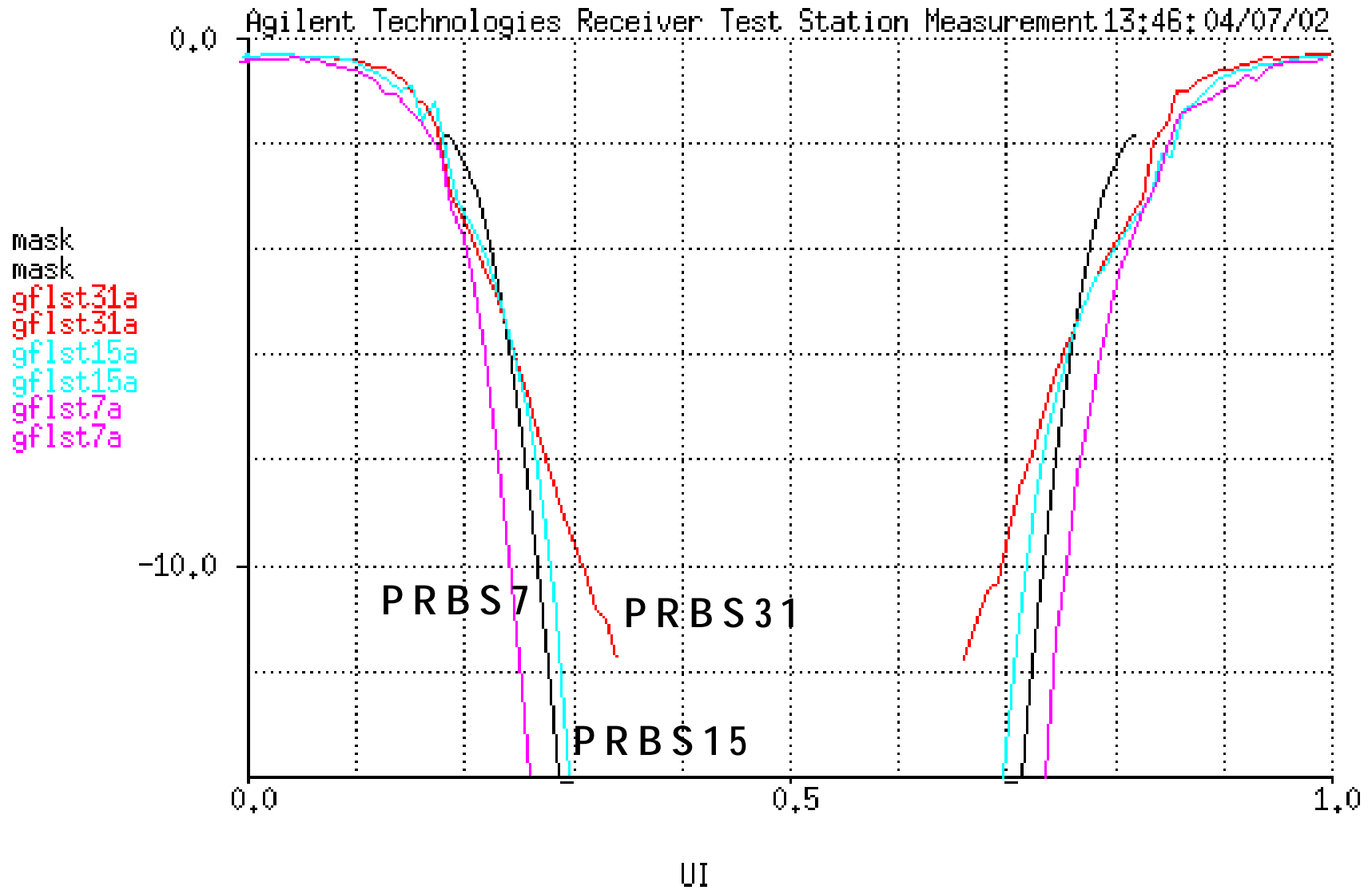

# Sensitivity Plot

Agilent Technologies Receiver Test Station Measurement 13:33:04/07/02

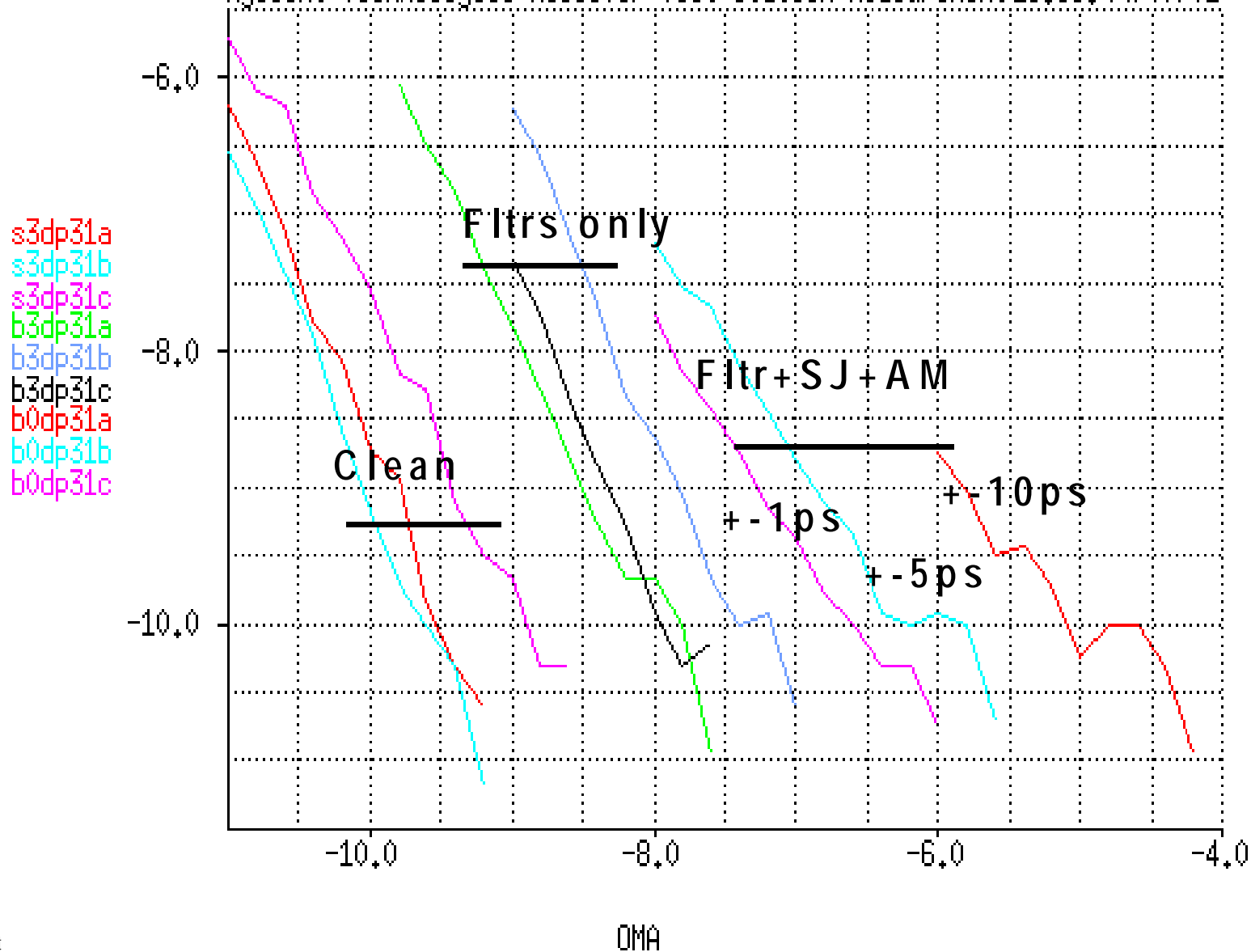

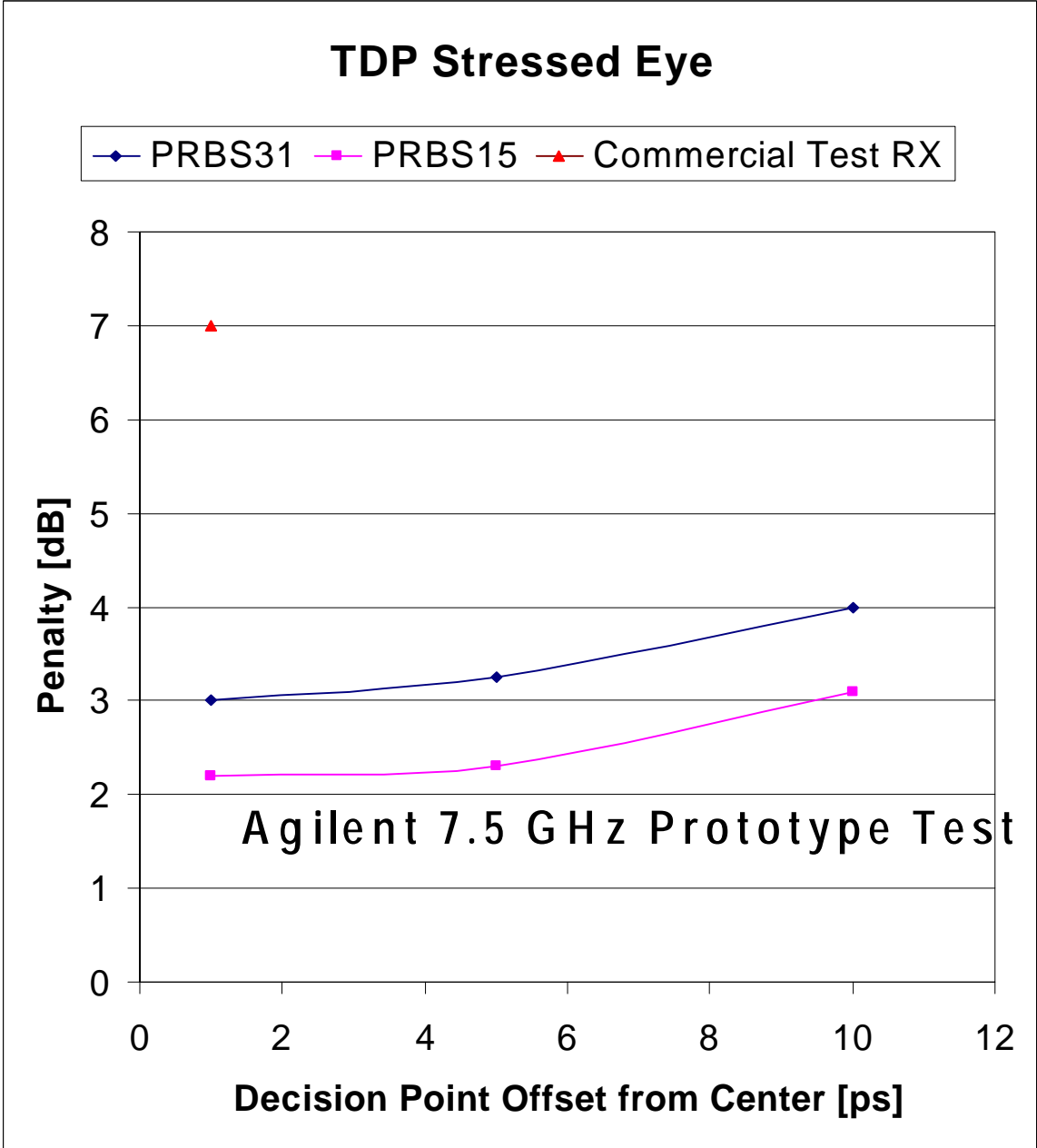

# Summary: 1

- Penalty observed with Agilent prototype reference receiver nearly matches the VECP, as predicted by theory. (2.2 to 4 dB)- dependent on pattern and decision point offset
- *Penalty observed by typical receivers exceed the apparent VECP!* Penalty with Commercial Test RX/BERT- 7dB
- Why? Mainly because typical receivers are not ideal.
- Secondly, because the stressed eye has some low probability eye closure.
- "Sigma" in BT curves increases slightly by adding filters
- "Sigma" is slightly dependent on pattern length
  - Small amount of residual baseline wander?
  - Non-ideal filter characteristics?
- Care required to minimize non-ideal effects in stressed eye

# Anonymous Reports from Vendors

- Some have reported success in constructing Stressed Eye
- Most report transmitters passed the TDP test with Available Reference RX
- A concern is getting DUT RX to pass 1550 nm Stressed Sensitivity Test
- Example: 1550 nm case,
  - 3 dB VECP stressed eye: Stressed Sens - Nom Sensitivity = 5 dB

## Summary:2

- The stressed eye will screen out inferior receivers.
- A small to moderate excess penalty can be compensated by better nominal sensitivity.
- Conclusion: Stressed Eye is a stringent, but fair test of receiver quality