

# Synchronization Requirements in Cellular Networks over Ethernet

IEEE 802.3 TS Interim, May. 2009

J. Kevin Rhee<sup>1</sup>, Kyusang Lee<sup>2</sup>, and Seung-Hwan Kim<sup>3</sup>

<sup>1</sup> KAIST, <sup>2</sup> ACTUS Networks, and <sup>3</sup> ETRI, S. Korea

# Acknowledgment

- Chankyun Lee, KAIST
- SeongJin Lim, KAIST

# Mobile Cellular Network: WiMAX/EV-DO

**AAA** Authentication, Authorization and Accounting  
**ACR** Access Control Router  
**AR** Access Router  
**BR** Broader Router  
**GSN** GPRS Support Node  
**HA** Home Agent  
**IMS** IP Multimedia Sub-system  
**PSDN** Packet Data Serving Node  
**RAS** Radio Access Station

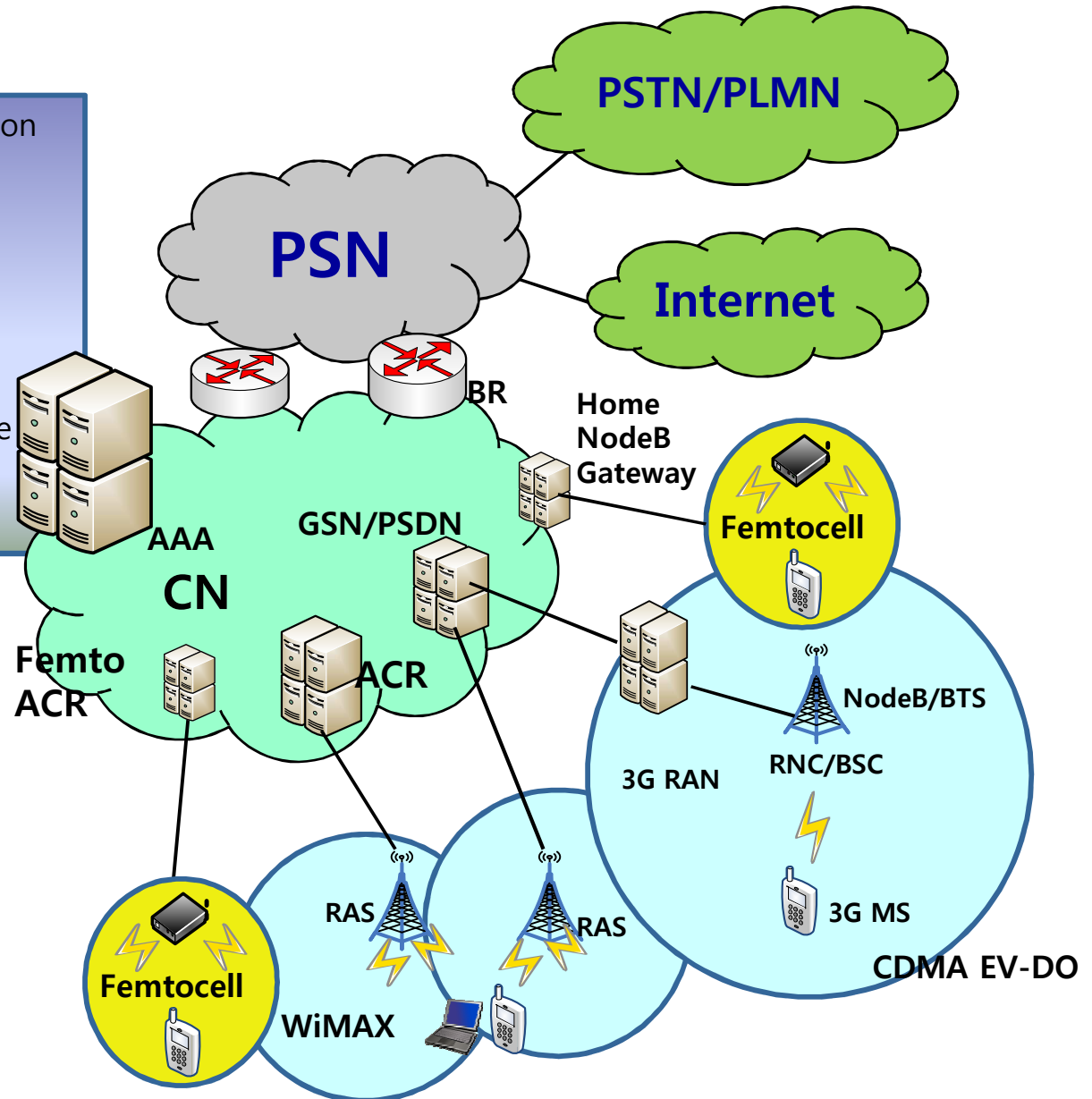

# Wireless backhaul

- Wireless backhaul network connects wireless base stations to the corresponding BSC
- It delivers the expected bandwidth requirements of new technologies such as WiMAX, 3G, and 4G.
- PSN and TDM can be used for wireless backhaul network

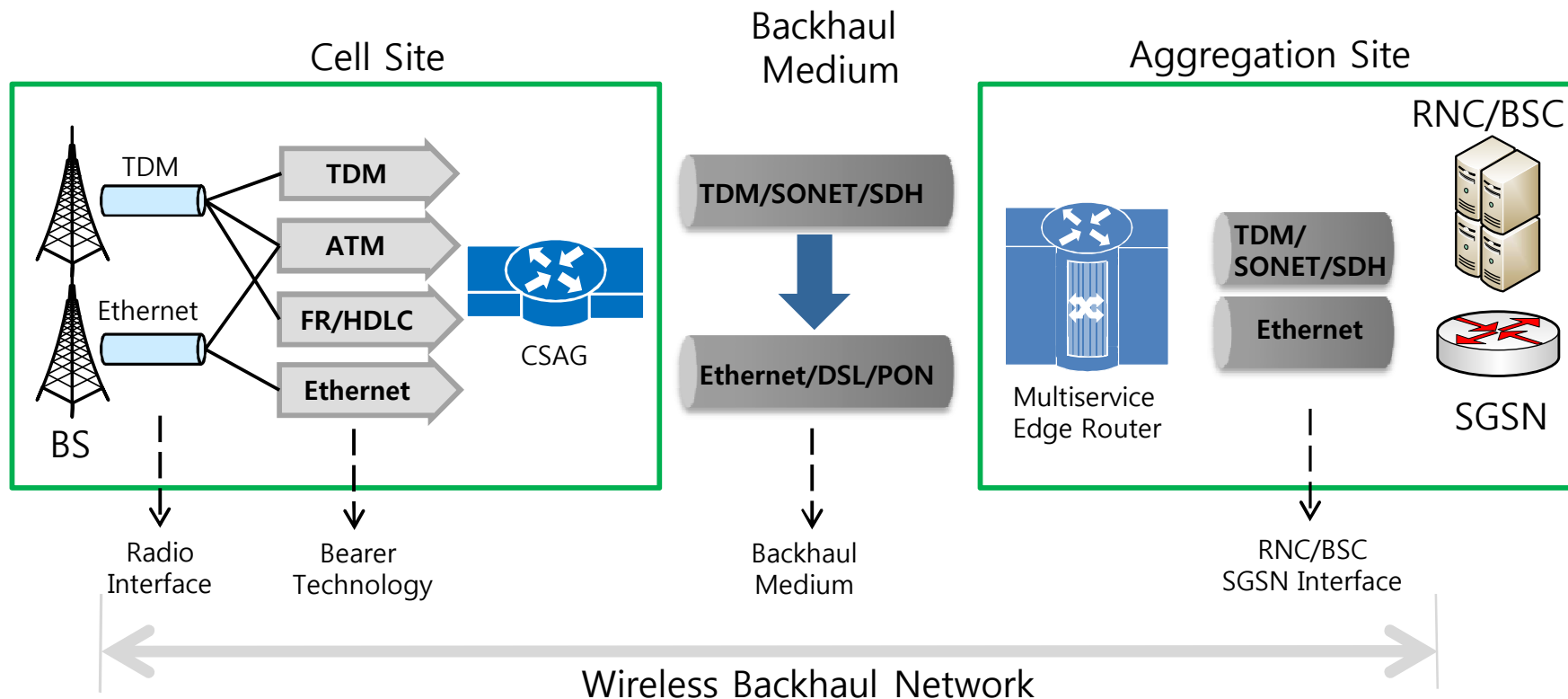

# Backhaul Market Growth

- 3G and 4G is driving 25-40% a year growth in mobile backhaul traffic
- The Carrier Ethernet markets are expected to increase 76% by 2011
- Data oriented mobile traffic is increasing
- Legacy TDM-based system is being replaced packet-based Ethernet solutions (More bandwidth per connection)

## MOBILE BACKHAUL

Aggregate Global Mobile Traffic  
Mbps in Millions

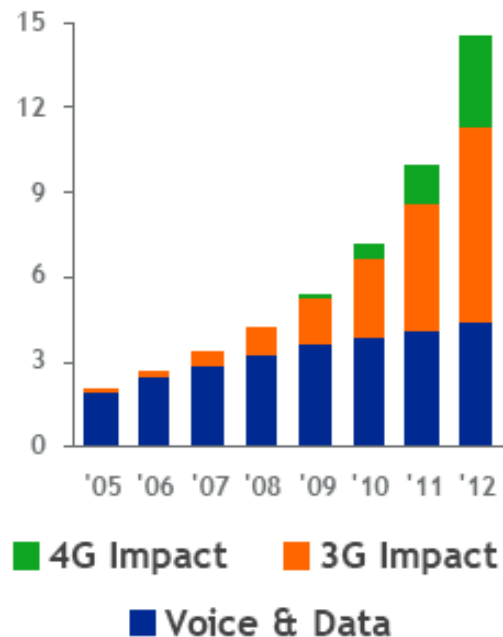

■ 4G Impact ■ 3G Impact

■ Voice & Data

Source : Nortel , June 11 2008

## Ethernet vs. PDH/SDH Microwave Equipment Worldwide Revenue Share

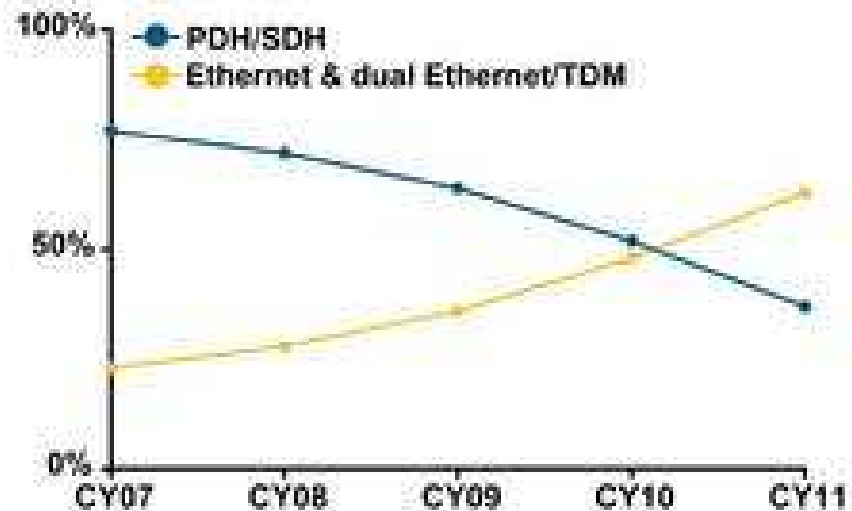

Source: Infonetics Research, Microwave Equipment Market  
Outlook March 2009

# Carrier Class Ethernet Backhaul

- PSN(ETH, IP/MPLS) has been replacing TDM networks (SDH/PDH)
  - Cheaper CAPEX and OPEX
  - High Utilization
- However, it needs guaranteed
  - Network Resilience
  - Fault/Performance monitoring via OAM
  - QoS, Delay, Jitter
  - Timing/Synchronization transport
- Ethernet should support the aforementioned functions and meet time/sync requirements!!

# Synchronization in Backhaul

- Why Synchronization?
  - BTS/NodeB are synchronized to BSC, RNC, MSC, and MGW for end-to-end sync
  - For Radio Framing Accuracy and Hand-over, 0.05ppm sync at BTS/NodeB is needed
  - Significant to interference control on cell boundaries

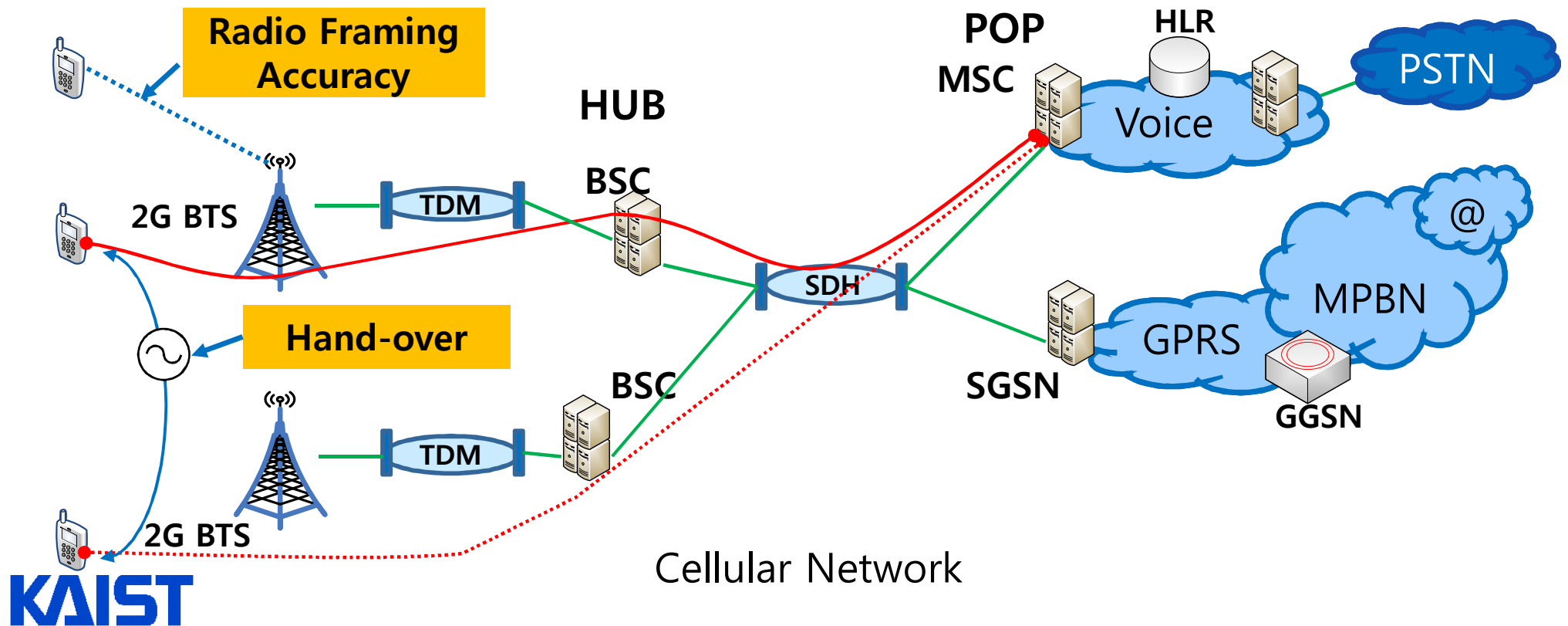

# Requirements of backhaul synchronization

## - Synchronization in 2G/GSM

- Sync requirement in legacy 2G/GSM
  - SDH freq. sync:  $\pm 50\text{ppm}$
  - BTS freq. sync:  $\pm 0.05\text{ppm}$
  - Ref. clock is distributed via SDH/PDH
- Sync requirement in future 2G/GSM
  - PSN freq. sync: Not strict
  - BTS freq. sync:  $\pm 0.05\text{ppm}$
  - Ref. clock is distributed via PSN
    - IEEE 1588 is being used.

Source: A. Zhou, X. Duan, "Requirements and viewpoints for backhaul synchronization," IETF TICTOC WG, Mar, 2008

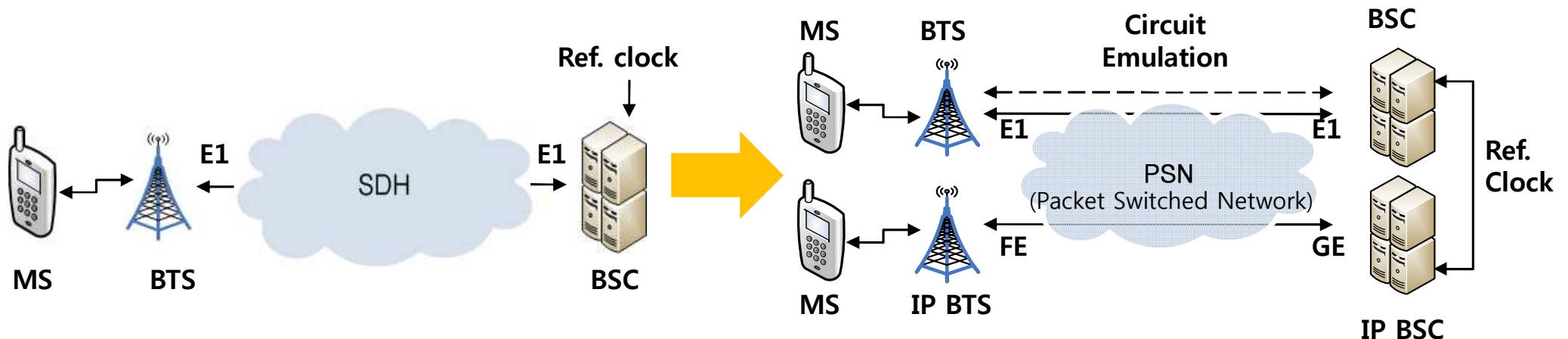

# Requirements of backhaul synchronization

## - Synchronization in 3G/TD-CDMA

- Sync requirement in legacy 3G/TD-CDMA
  - SDH freq. sync:  $\pm 50\text{ppm}$
  - BTS freq. and phase sync:  $\pm 0.05\text{ppm}$  and  $\pm 3\mu\text{s}$
  - Ref. clock is distributed via SDH/PDH for transport network.
  - BTSs are synced via GPS.
- Sync requirement in future 3G/TD-CDMA
  - BTS freq. and phase sync:  $\pm 0.05\text{ppm}$  and  $\pm 3\mu\text{s}$ 
    - IEEE 1588 is being used for frequency and phase sync.

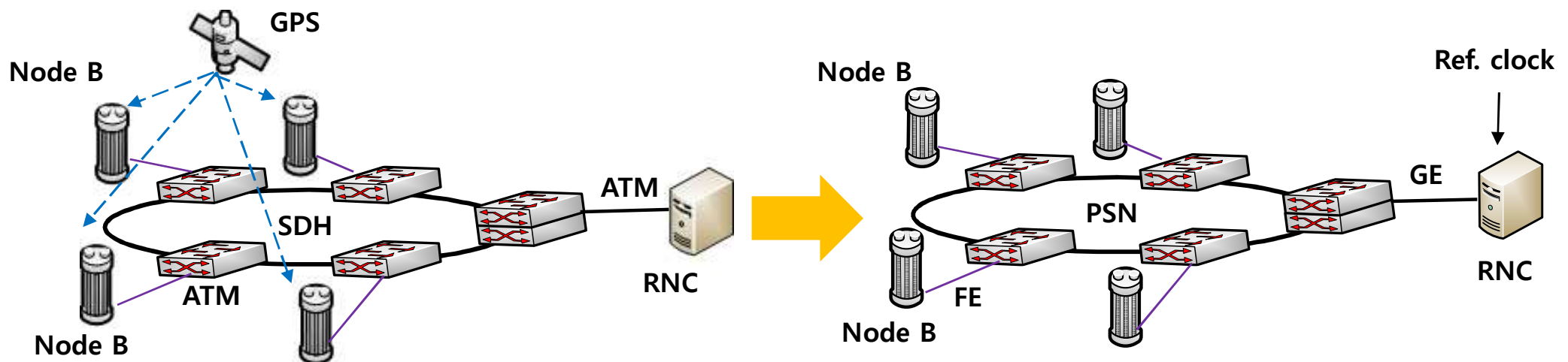

# Next major market opportunities

## - Sync requirements of Femtocell and WiMAX

- Femtocell
  - The small cell deployed indoors, which communicates with cellular network over a broadband connection.
- Synchronization of Femtocell
  - Related handover and interference.
  - Time sync accuracy (Timing difference bet. Macro BS and the Femto BS)
    - $0.2 \mu\text{s}$  (The distance bet. Femto BSs = 30m)
- WiMAX
  - Freq. and phase accuracy by WiMAX Forum: 2ppm,  $1 \mu\text{s}$  (for TDD)
  - IEEE 1588 over IP/Ethernet backhaul
    - Low-cost-standalone solution
    - Provides sub microsecond accuracy
    - IEEE 1588 to WiMAX/Femtocell is under study at IEEE 802.16m.

Source: WiMAX Forum Tech. WG, "WiMAX Forum Mobile System Profile Specification: Release 1.5 Common Part," rev. 0.2.1, Feb 2009.

Source: Guang Han, et al., "Time synchronization for Femtocells," IEEE 802.16m, Oct2008

# Summary of synchronization requirements

- Two mobile wireless network sync schemes
  - FDD radio-based mobile wireless sync
    - WCDMA FDD in GSM and FDD LTE
    - Freq. accuracy: 0.05ppm
  - TDD radio-based mobile wireless sync
    - It requires freq. accuracy, phase alignment, and time alignment.
    - CDMA, cdma2000, Mobile WiMAX 802.16e, TDD LTE
    - Freq. accuracy: 0.05ppm
    - Inter-BTS time alignment:  $2.5\mu s$  to  $10\mu s$

## <Summary of synchronization Requirements>

	GSM/WCDMA/ CDMA2000	TD-CDMA	WiMAX	Femtocell
Freq. accuracy	0.05 ppm	0.05 ppm	2 ppm	
Timing accuracy		$3\mu s$	$1\mu s$ (for TDD)	$0.2\mu s$

Source: Patrick Diamond, "Packet Synchronization in Cellular Backhaul Networks," Semtech White Paper Oct. 2008)

Source: S.-P. Yeh, et al, "WiMAX Femtocells: A Perspective on Network Architecture, Capacity, and Coverage,"  
IEEE Comm. Mag., Vol. 46, Issue 10, Oct. 2008

Source: V. Chandrasekhar, et al., "Femtocell Networks: A Survey," IEEE Comm. Mag., Vol. 46, Issue 9, SEP. 2008

# Supports of 1588 & 802.1AS

- Using IEEE 1588 for WiMAX may be adequate.
  - However, it is not suitable to support legacy 2G/3G, and 4G.
  - IEEE 1588 or 802.1AS should support sync requirements for legacy systems and new systems.
  - More accurate timestamp function is needed!!
  - Options
    - Use of very accurate clock
    - Timestamp in physical Layer

# Architectural consideration of timestamp for 802.3

Eg. 802.3ba model

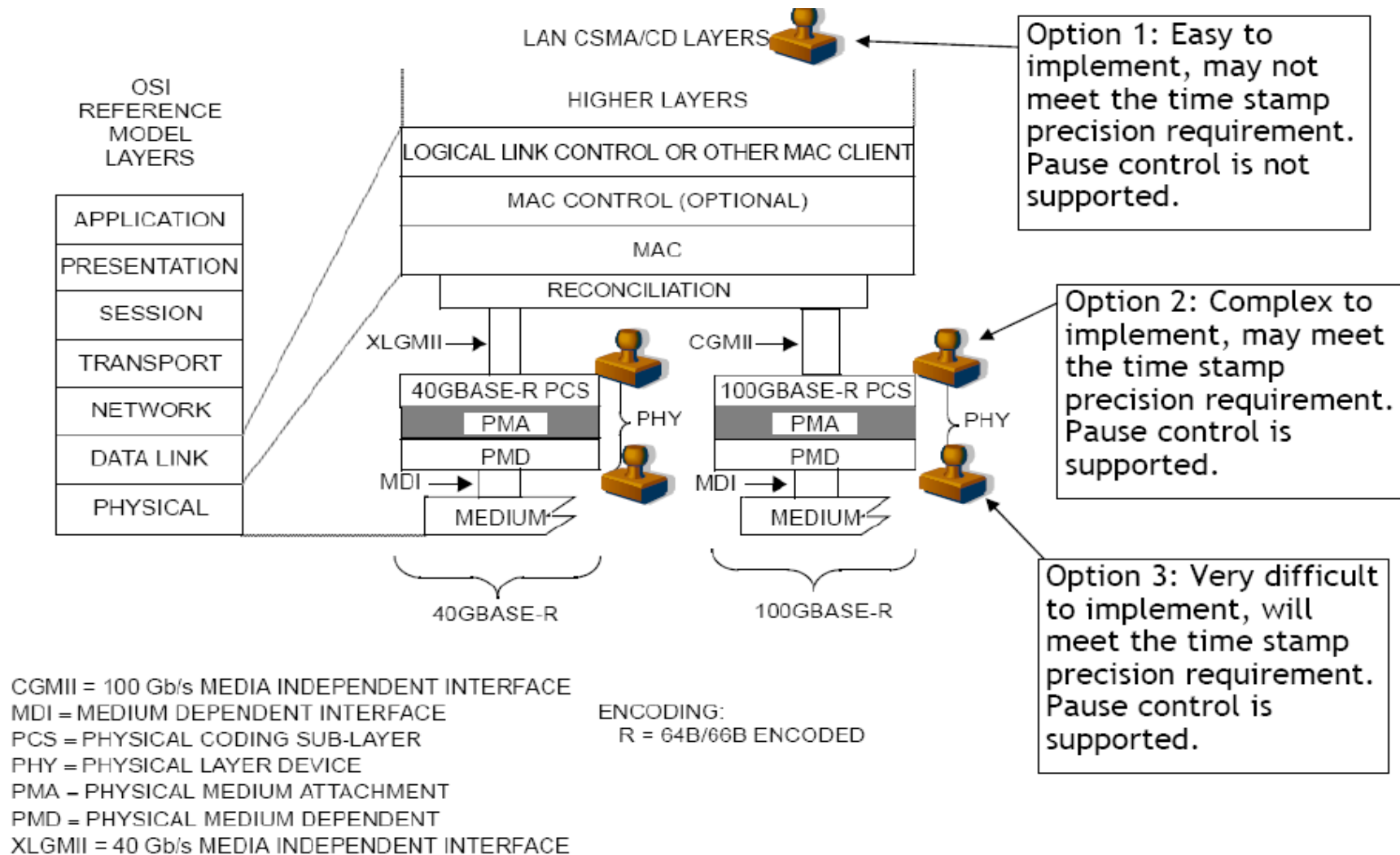

Figure 153-1—40GBASE-R and 100GBASE-R PMA relationship to the ISO/IEC Open Systems Interconnection (OSI) reference model and IEEE 802.3 CSMA/CD LAN model

# Conclusions

- Time synchronization in fast growing mobile backhaul market
  - Time sync application in the backhaul market is anticipated to be even larger than AV applications in the near future.
- IEEE 1588 and IEEE 802.1AS will be the major solutions.
  - Multi-hop Precision Time Protocol will be used.
  - PTP messages will be transported over wired/wireless multi-hops.
- Current timestamp at MAC or client layer may not be qualified for ppb level synchronization accuracy requirements.
- IEEE 802.3 needs to provide more accurate timestamp information.
  - IEEE 802.3 may require a timestamp function in the PCS, PMA, or PMD sublayer.