

Multi-Level Analog Signaling Techniques for 10 Gigabit Ethernet

MAS Tutorial Presenters

- Rich Taborek - MAS PHY Architecture
 - ◆ Principal Architect
 - 650 210 8800 x101, rtaborek@transcendata.com
- Bob Dahlgren - Fiber Optic Components
 - ◆ Director, Fiber Optic R&D
 - 650 210 8800 x103, bob@transcendata.com

Transcendata, Inc.

1029 Corporation Way, Palo Alto, CA 94303

MAS Tutorial Agenda

- Introduction
- Alternatives: T-Wave, PAM, QAM
- Architecture
- PMA
- PMD - focus on Laser Linearity
- PCS
- Acknowledgements

Introduction: What is MAS?

- MAS is a generic term used to describe various methods of Multilevel Intensity Modulation
- Multilevel modulation is applicable to most media including Copper, Wireless, Fiber, etc.
- Methods include T-Waves, PAM, QAM, etc.
- Multilevel signaling lowers the line rate for a given payload rate - reducing system cost and increasing distance

Impetus for MAS

- MAS previously deemed unnecessary for Optics
 - ◆ Binary signaling was sufficient for the LAN & WAN
 - ◆ Fiber was assumed to have infinite BW - It does NOT!
- Even for 1.25 Gbps, limitations were noticed in attempting to go faster and farther than 1 Gbps
 - ◆ Distances reduced from original GbE objectives
 - ◆ New phenomena found (e.g. DMD, MMF launch)
- MAS is dominant in modems, DSL, Cu Ethernet...
 - ◆ Invaluable to re-use existing cable plants at higher rates
- 10 GbE places 10× demands on media BW

Technology Basis

- Trade off silicon capability against laser/optics and high-frequency electronics complexity and cost.
- Bet that silicon costs less and that cost will continue to improve faster than the laser/optics high-frequency electronics.
- “Lasers don't follow Moore's Law.” - Piers Dawe, HP
- Compared to copper, fiber has higher bandwidth.
 - ◆ No hard requirement to use multiple channels like UTP
 - ◆ No hard requirement to use high-speed compensation

Features

- MAS enables a single integrated PHY solution
 - ◆ Applicable to MMF, SMF, Short-haul Copper
 - ◆ Applicable to SX, LX, EX, CX variants
- GbE Auto-Negotiation capable
- Open Architecture, no IP, proven technology base
- Compatible with single or multi-channel optics
 - ◆ MAS w/Multi-channel optics enable higher speeds
 - ◆ Parallel fiber or WDM multi-channel
 - ◆ 40 Gbps or more possible

Economics

- Driving towards low-cost CMOS to:
 - + Reduce optics cost
 - + Increase optical link budget
 - + Increase PHY reliability, especially Laser
 - + Decrease system BER
- Lower Baud to simplify critical electronics design: CDR, Optoelectronics, signal integrity and EMC
- Enables the use of One low-cost laser
- Enables integrated PHY Transceiver product

MAS Alternatives

- T-Waves
- PAM
- QAM

T-Waves

- Synthesized, Multilevel, Intensity Modulation
 - ◆ Waveform synthesis/Waveform capture
- Narrowband Frequency Spectrum
 - ◆ Approximately $f/2$ to $1.5f$
 - ◆ Reduced spectrum compared to OOK and PAM
- High Resistance to Dispersion and Nonlinearity
 - ◆ System is loss-limited, not dispersion-limited
 - ◆ Simple sine-wave modulation enables mechanisms to characterize and compensate for dispersion and media impulse response

T-Wave Signaling

T-Wave5 Example

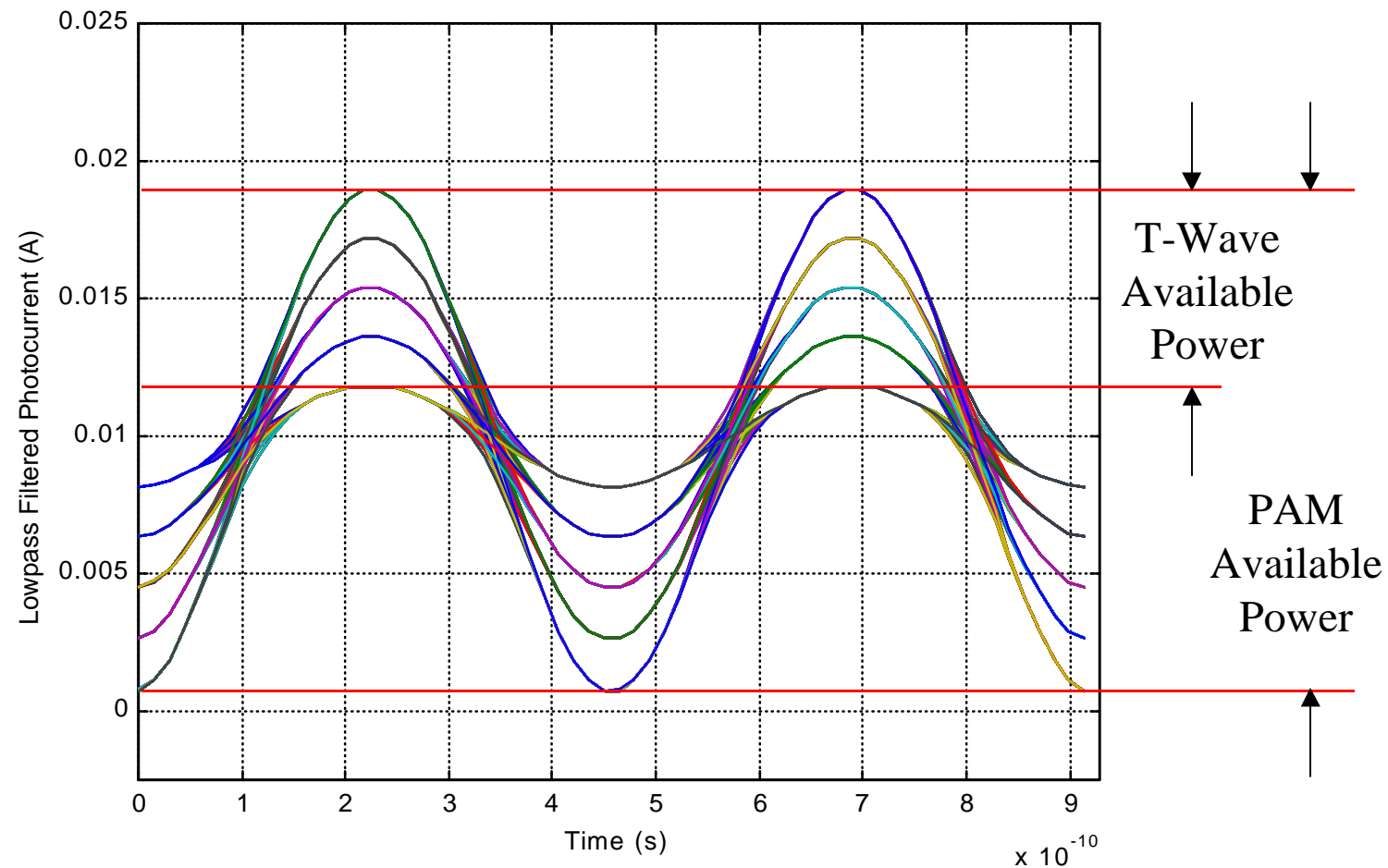

Received pattern from simulation - Transcendata

Pulse Amplitude Modulation Basics

- Most existing optical links employ binary signaling a.k.a. On-Off-Keying (OOK), PAM2, Serial TDM
 - ◆ Each transmitted symbol represents just one bit (0 or 1)
- PAM n , where $n > 2$, transports > 1 bit/Baud
 - ◆ PAM3 and above lowers line rate but decreases SNR
 - ◆ PAM3 (e.g. MLT-3), decreases SNR by 3 dB
- PAM5 provides better utilization of limited BW
- PAM5 is 250% as efficient as OOK & 8B/10B
 - ◆ 10 GbE: PAM5 @ 5 GBaud = OOK & 8B/10B @ 12.5 GBaud
 - ◆ 10 GbE: PAM5, decreases SNR by 6 dB

PAM Signaling

PAM5 Example

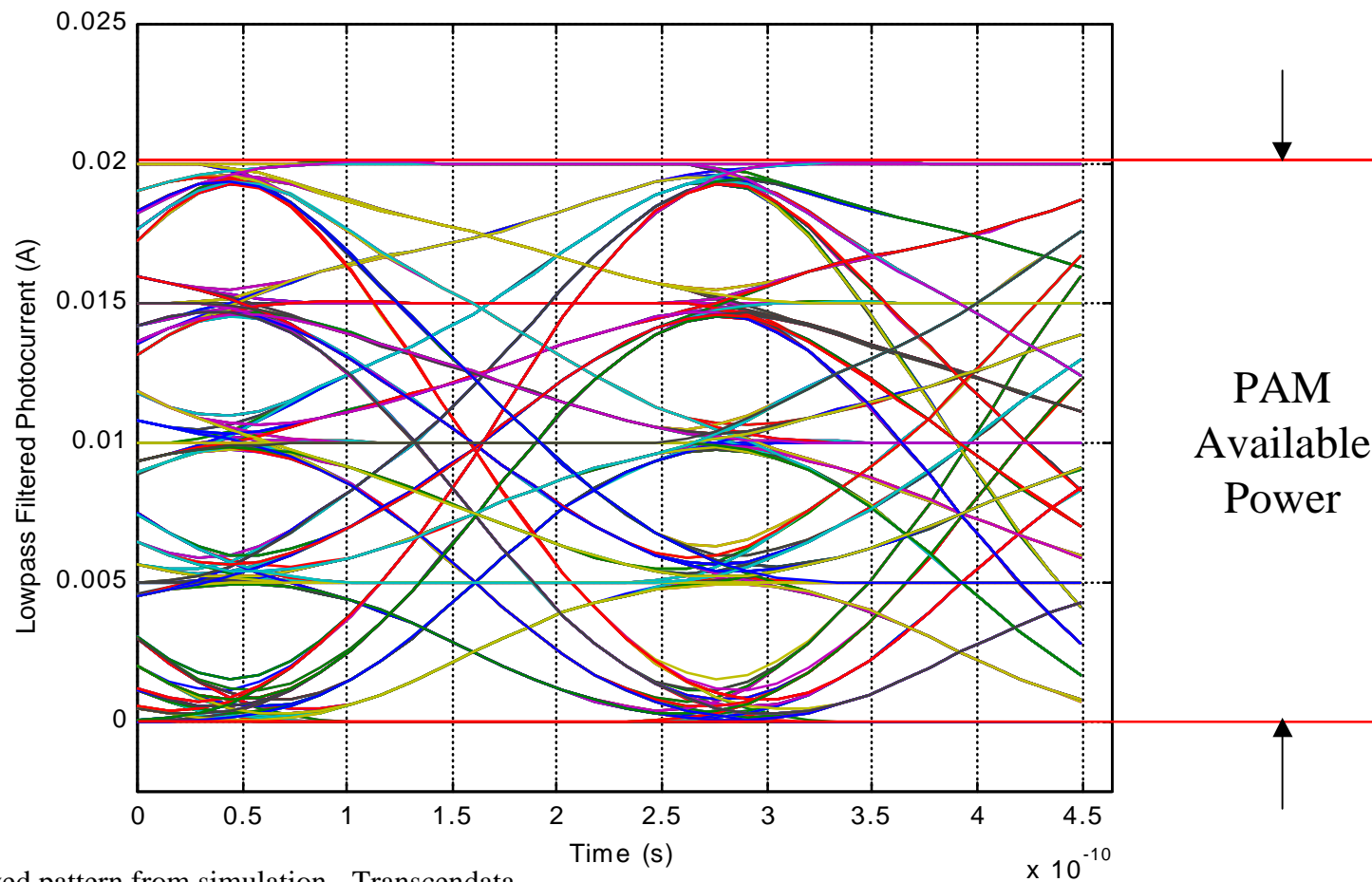

Received pattern from simulation - Transcendata

T-Wave vs. PAM

- Significant Link Penalty compared to PAM
 - ◆ 4.5 dB penalty for the same number of levels since only half of available levels, less average power, are used.
- Signal Compensation at multi-gigabit rates is complex and expensive in terms of logic
 - ◆ Probably not a good tradeoff for 10 GbE environments
- T-Wave Waveform Synthesis logic $3 \times$ PAM
- PAM is more efficient, simpler in ‘easy’ environments (e.g. most 10 GbE applications)
- + T-Waves may be more efficient in ‘difficult’ environments (e.g. very long links, high dispersion)

Optical QAM

- Many Quadrature Amplitude Modulation techniques are possible.
- QPSK is the simplest form of QAM (QAM4)
 - ◆ Multicarrier Modulation (MCM)
 - Multiple digital streams are modulated onto carriers at different frequencies, permits transmission with minimal ISI.
 - ◆ Intensity modulation most applicable to optical systems
- Overkill in complexity for 10 GbE
 - ◆ Work in Progress: Roy You and Joseph M. Kahn, “Average-Power Reduction Techniques for Multiple-Subcarrier Optical Intensity Modulation”, IEE Colloquium on Optical Wireless Communication, London, England, June 22, 1999.

MAS Alternatives - Direction

- T-Waves
 - ◆ Large Optical Penalty, Too Complex for 10 GbE
- ✓ PAM
 - ✓ Best Tradeoff between Cost and Complexity
- QAM
 - ◆ Too Complex for 10 GbE, need RF carrier(s)

MAS Basics - Line Rate Reduction

- Reduce line rate to support 10 GbE to 5 GBaud
 - + Use multi-level signaling, PAM5 to increase #bits/Baud
 - + 5 GBaud = 2.5 GHz enables the use of low cost CMOS
 - + Enables the use of low cost Lasers (e.g. OC-48)
 - PAM5 signaling costs 6 dB in SNR
 - + Get back >6 dB with Forward Error Correction (FEC)
 - ± FEC adds latency/costs gates. Impact negligible
 - PAM5 needs nominally linear lasers & signal symmetry
 - + Linearity requirements offset by Link Calibration

MAS Basics - One vs. Multi-Channel

- Reduce cost/complexity by using one channel
 - + Fiber has sufficient bandwidth, unlike UTP
 - + One channel is cheaper/simpler than 2/4/8/12, etc.
 - + One channel is more reliable than multiple channels
 - + No multiplexing of data streams required
 - + No skew management and associated delay
 - + MAS channels can directly feed a “dark wavelength” to enable higher data/rates

Signal Design Challenges

- 10 GbE serial data stream transmission presents several design challenges.
 - ◆ High speed logic requirements, $10 \times$ GbE, CDR, Optics
 - ◆ Attenuation
 - ◆ Dispersion/Group Delay
 - ◆ Noise from increased Bandwidth
 - ◆ Crosstalk
 - ◆ Signal Integrity and Transmission Line Effects
 - ◆ Parasitic effects in Components and Packaging
 - ◆ Electromagnetic Emissions and Susceptibility

MAS Circuit Design Challenges

- Waveform Synthesis and Capture
 - ◆ 5 GigaSymbols per second (Gsps)
- Clock and Data Recovery
 - ◆ Low Jitter PLL for PAM5 clock & data recovery
- Forward Error Correction (FEC)
 - ◆ TBD, focusing on Reed-Solomon codes
 - ◆ High efficiency, high coding gain, negligible latency
 - ◆ E.g. RS(255,239) code in 10^{-4} BER, out 10^{-14} BER

CMOS Capabilities

- Submicron CMOS can achieve 10 Gbps
- Reference designs:
 - ◆ Farjad-Rad, Ramin, et al, “0.4um CMOS 10-Gbps 4-PAM Pre-Emphasis Serial Link Transmitter”, IEEE JSSC Vol. 34 No 5, May 1999
 - ◆ Ellersick, W., et al, “A 12-GS/s CMOS 4-bit A/D Converter for an Equalized Multi-Level Link”, IEEE 1999 VLSI Circuits Symposium, Kyoto, Japan
- Example gate delay per inverter in ring oscillator

0.35 um	55 ps
0.25 um	40 ps
0.18 um	30 ps ➡ 33 GHz

+ Low cost, High Density and readily available

MAS 10 GbE Technology Basis

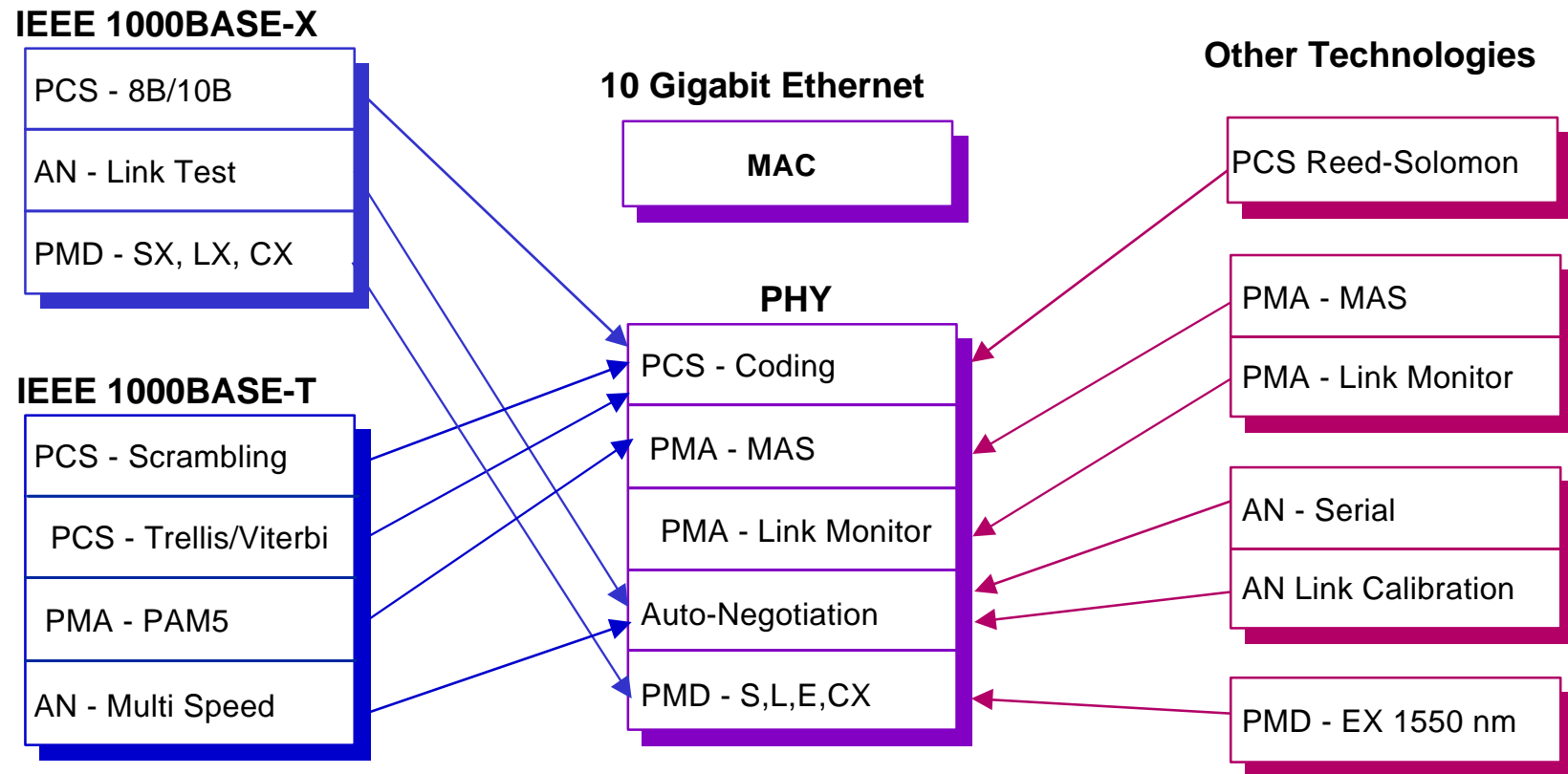

MAS Architecture

Media Access Control (MAC) - Full Duplex

Media: Short Chip Interconnect/PCB Trace

10 Gigabit Media Independent Interface (XMII)
Parallel 8, 16, 32 bits each way

Media: Short Chip Interconnect/PCB Trace

10 Gigabit PCS/PMA Interface
Serial 2.5 - 3.125 Gbps \times 4

Media: Long PCB Trace/Short Coax

10 Gigabit Transceiver
PAM5 - 5 GBaud

Media: CX, SX, LX, EX: 2 m - 40+ km

MAS Block Diagram - Transceiver

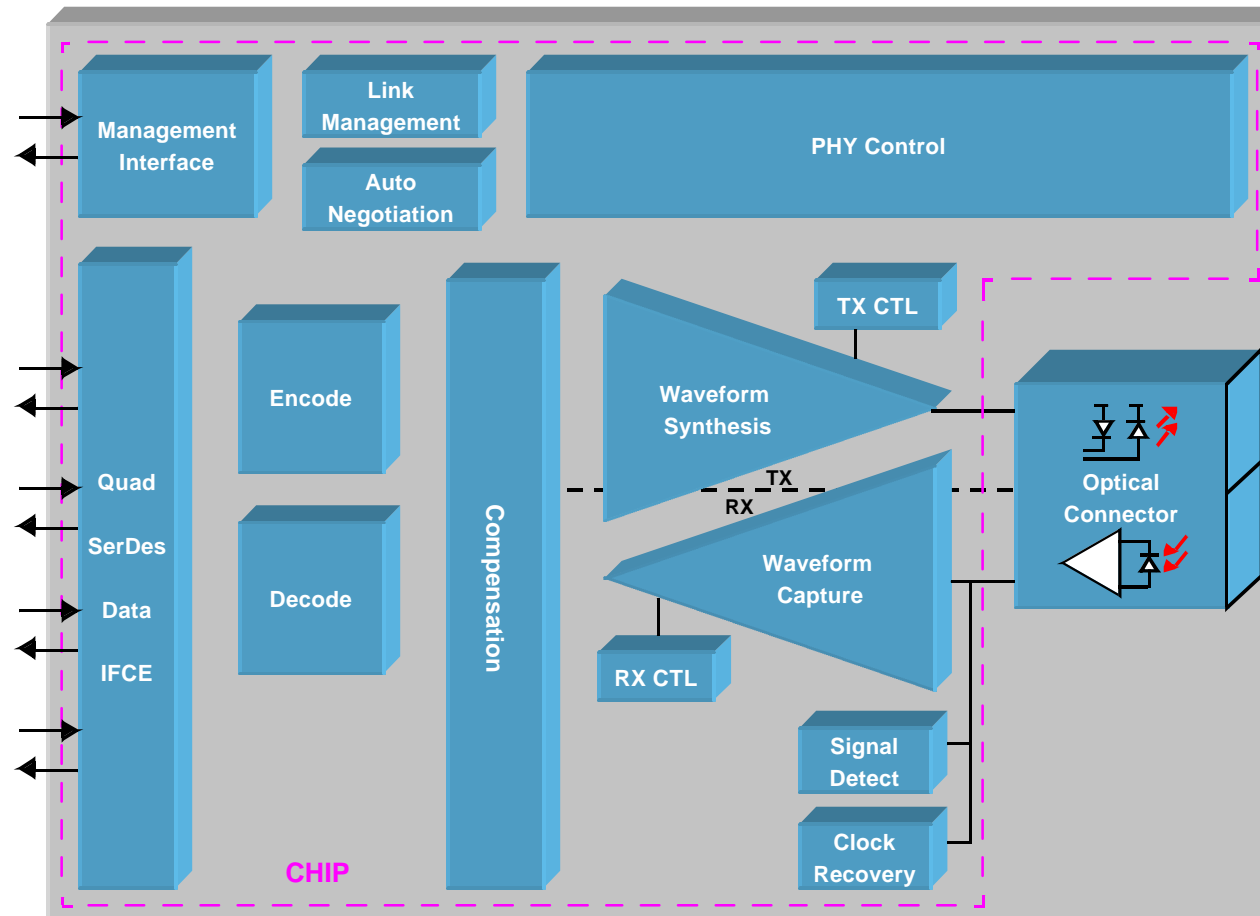

Optics Version shown, Alternatives: CX Version

MAS Link Elements

- Contain high-speed logic to Transceiver
- Support flexible interfaces to MAC
 - ◆ Quad Serial 2.5 - 3.125 Gbps to Transceiver
 - ◆ Provides flexible MAC/PHY to Transceiver interconnect
 - ◆ Per Cisco July; HP, Sun, TI June proposals
 - ◆ Applicable to MAS, Serial TDM, WDM, Parallel Optics
- PAM5 Transmission link operates independently of Quad Serial links to MAC/PHY at each link end

MAS System Structure Example

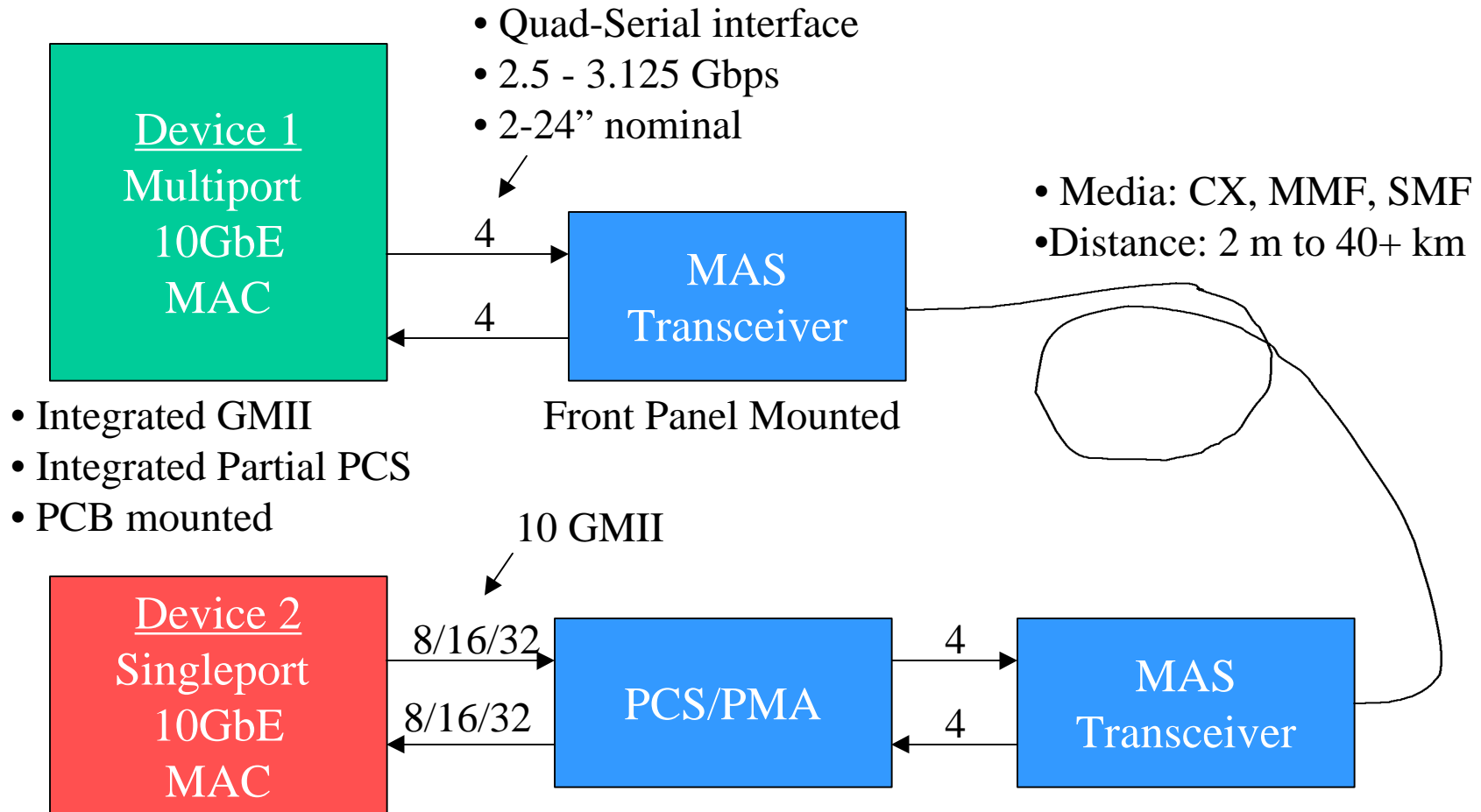

PMA - Binary vs. PAM5 Signaling

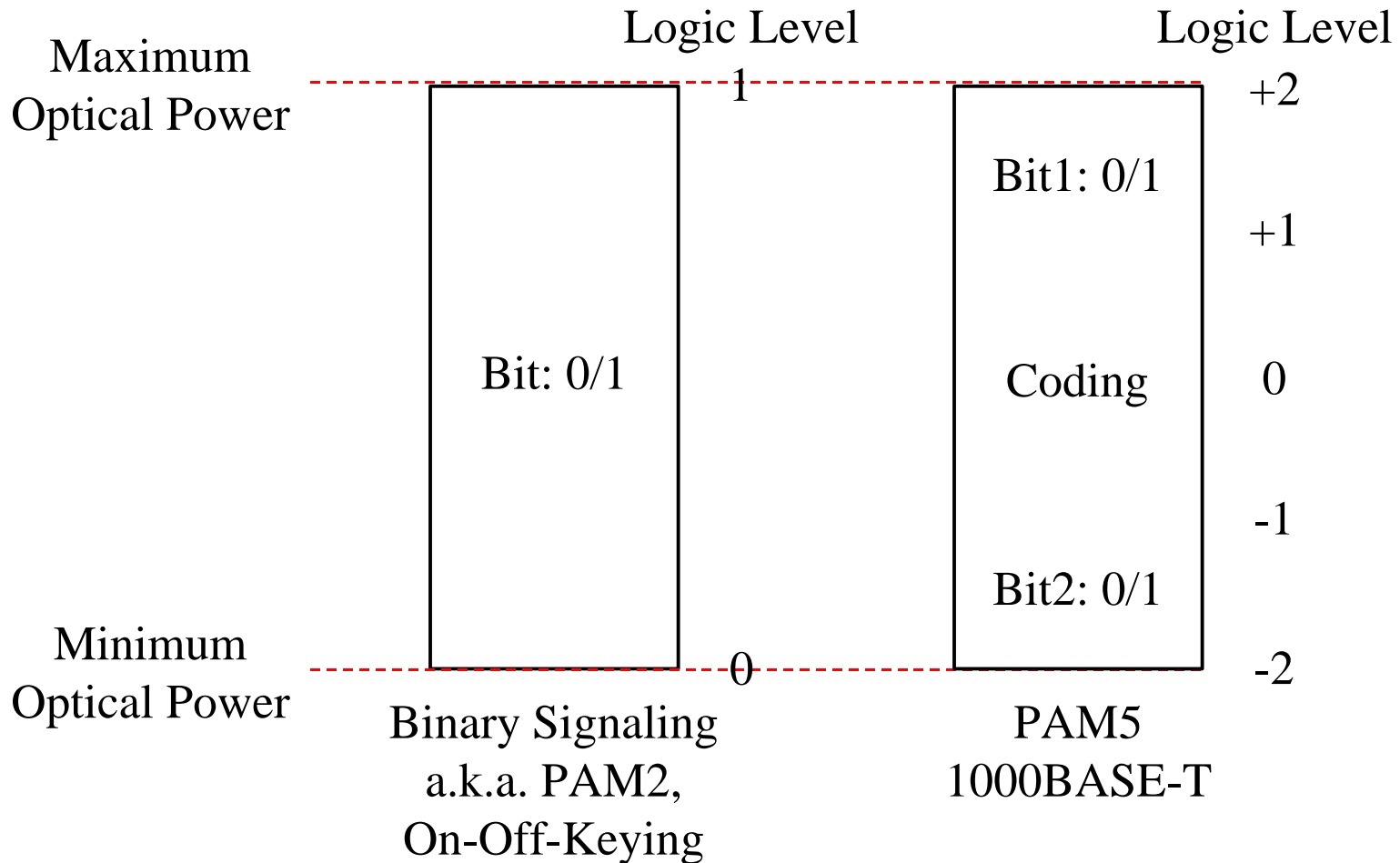

PAM's History in Ethernet

- 100BASE-TX uses multi-level coded symbols
- 100BASE-T4 uses multi-level coded symbols
- 100BASE-T2 uses PAM5
- 1000BASE-T uses PAM5

- MAS, PAM5, is NOT new to Ethernet

PAM5 in 1000BASE-T

- 1000BASE-T employs PAM5 on 4 channels
 - ◆ Symbols represents one of five levels (-2, -1, 0, + 1, +2)
 - ◆ Each symbol represents two bits plus one extra level
 - ◆ PAM5 SNR penalty is 6 dB
 - ◆ Extra level provides FEC, special codes, transition density
 - ◆ FEC buys back most of the SNR lost by PAM5
 - ◆ Equalization buys back the rest
 - ◆ 1000BASE-T utilizes PAM5 + FEC + Equalization to get 250 Mbps on each wire pair at only 62.5 MHz, allowing cat 5 UTP usage to 100 m.

PAM5 Eye Diagram on MMF

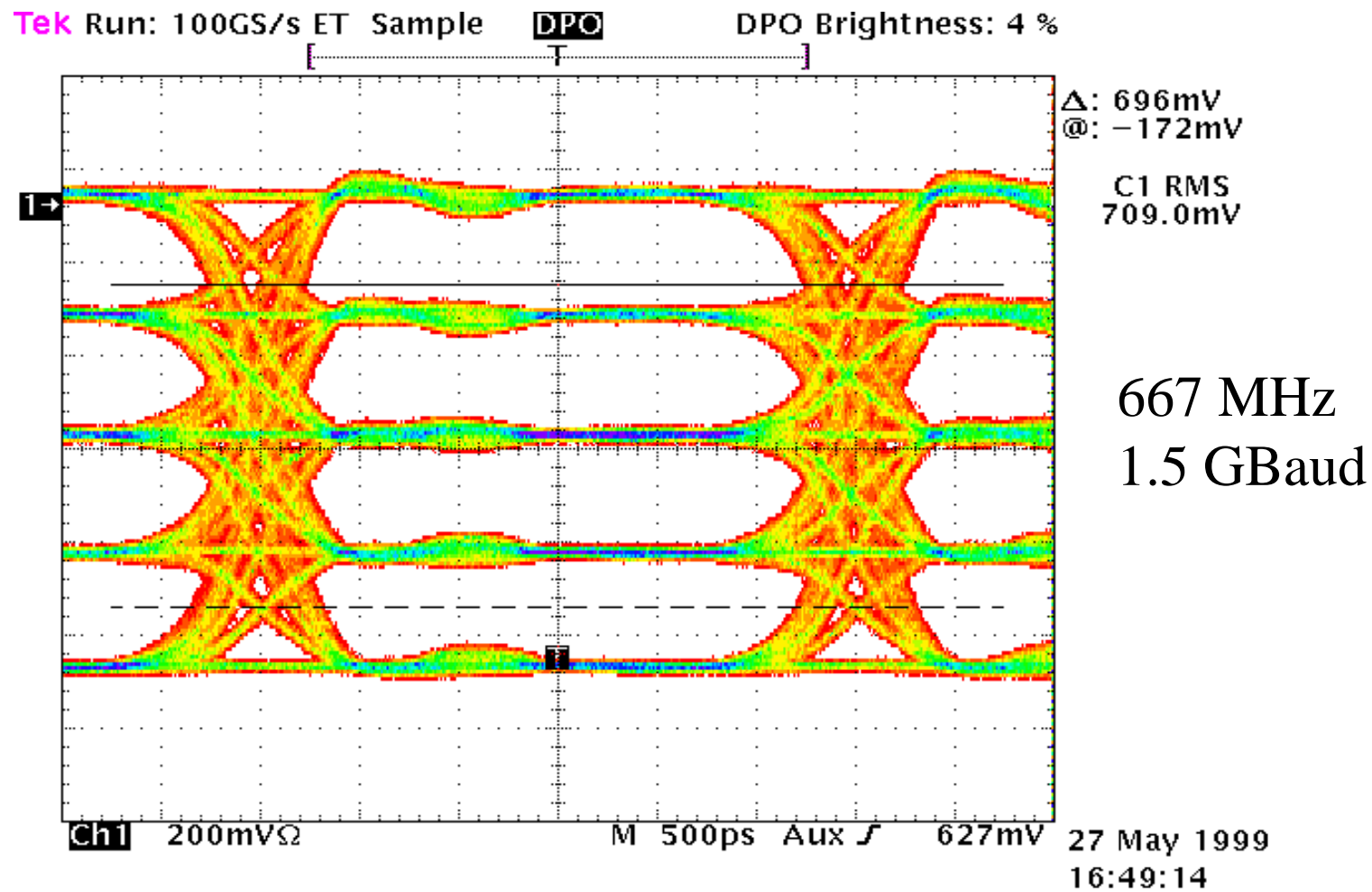

PAM5 Signal Appearance Example

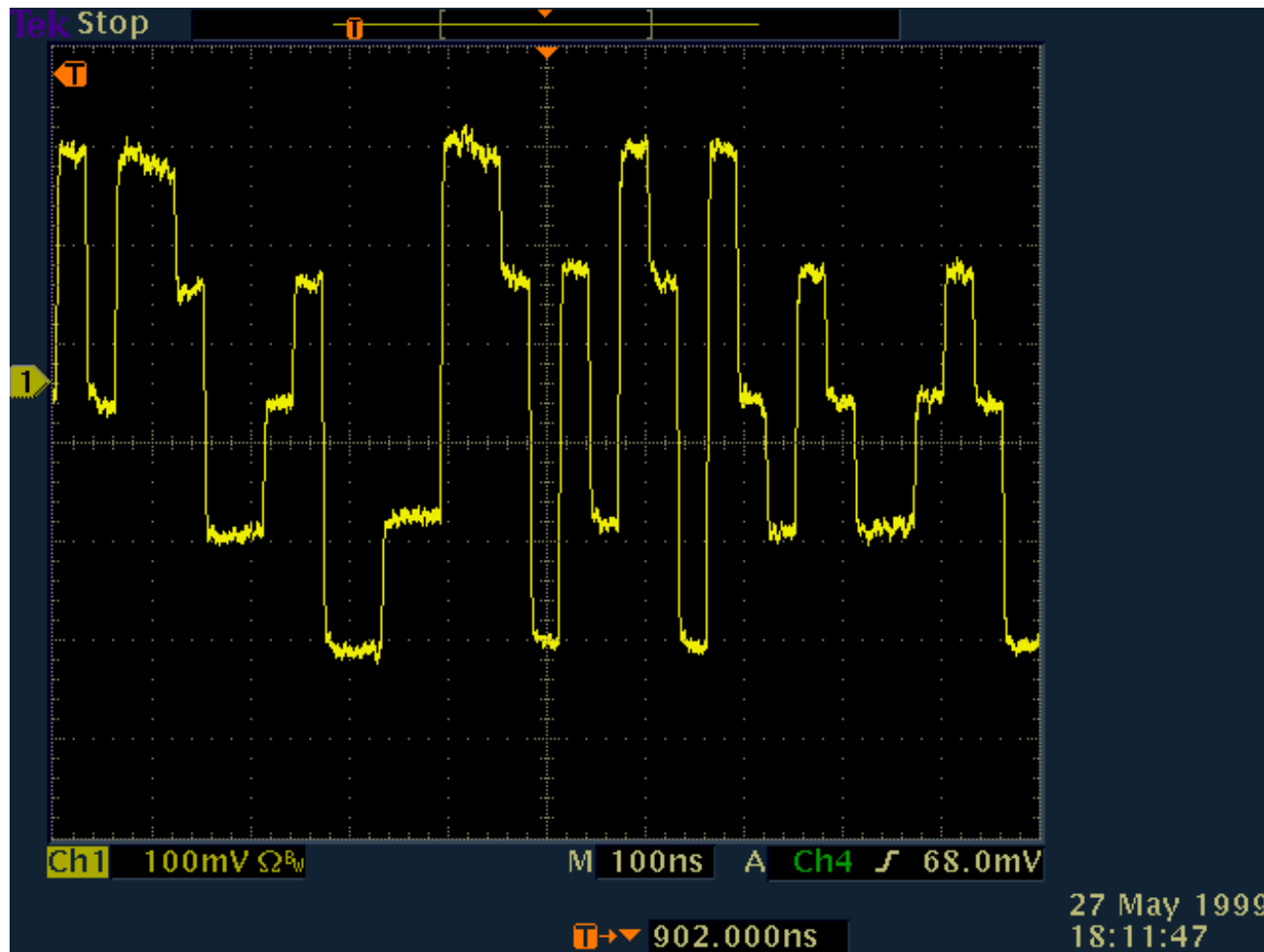

30 MHz
60 MBaud

PMD - MAS Optics

- Single Channel Basis
- Laser Diode
- Optical Receiver
- Packaging
- Optical Non-Issues
- Power Penalties

Optical Issues: One vs. Multi-Channel

- Electrical Crosstalk $N(N-1)$ terms ($N=\text{\#channels}$)
 - ◆ Coupling via parasitics, substrate, supply, etc.
- Optical Crosstalk $(2N-2)$ terms
 - ◆ Non-ideal demultiplexer filters or Rx isolation
 - ◆ Out-of-band LD emission or Tx isolation
- Optical Attenuation terms
 - ◆ Tolerancing in parallel mux/demux in WWDM
 - ◆ Additional loss penalty for WDM due to SM optical combiner and WDM demux splitter
- Optical Power Control Link Budget Penalties
 - ◆ Multi-channel power skew

OptoEconomics - MAS Transceivers

- Very mature technology
 - ◆ Dozens of optical module/transceiver vendors have experience with single-channel optics
- Low entry cost for prospective module vendors
- Complex optical schemes can lock out or substantially delay competitive entry
- Competition = Lower prices for end users
- Simplicity: Reduced parts count, Tolerancing
 - ◆ Single LD, PD, associated optics, coupling
- Single critical high-frequency electrical path

OptoEconomics - MAS LD Support

- LD cost dominates the cost of most optical PHYs
- Multiple Laser vendors interested in supplying optoelectronics suitable for MAS
- Indications that MAS Laser costs will compare to standard, low-cost OC-48 Lasers
- As usual, volume needed to drive costs down

Laser Diode Attributes

- Wavelength
- Optical Power
- Bandwidth
- Linearity
- Noise

Laser Wavelength - LW 1310 nm

- MAS independent of Laser Wavelength
 - ◆ Essentially a laser cost vs. distance tradeoff
- Longwave (1310 nm)
 - + Higher Class I Laser Safety limit (~ 6 mW)
 - + Low attenuation (< 0.5 dB/km)
 - + Bandwidth•distance product of legacy fiber is > SW
 - + Supports SMF and MMF
 - Mode conditioning required with MMF
 - + Higher reliability
 - + Lower LD bandgap and forward voltage
 - Cost penalty above shortwave lasers

Laser Wavelength - LW 1550 nm

- Longwave (1550 nm) all of 1310 plus:
 - + Higher Class I limit (~ 10 mW)
 - + Lower fiber attenuation (< 0.4 dB/km)
 - Cost penalty above LW 1310 nm lasers
 - + Cost penalty may be due to volume difference
 - + Can use temperature control to assign to a specific ITU-grid wavelength for DWDM
 - + Compatible with EDFAs
 - Higher dispersion unless Dispersion Shifted Fiber (DSF) is used

Laser Wavelength - SW 850 nm

- Shortwave (850 nm)
 - + Low cost VCSELs
 - Low Class I limit (~ 0.35 mW)
 - High fiber attenuation (< 3.5 dB/km)
 - + High bandwidth (to ~ 2.2 GHz \cdot km) on enhanced MMF

Laser Optical Power

- Maximum power set by laser safety limits, nonlinear threshold, drive, reliability, or receiver saturation, whichever is the lowest.
- Minimum power set by worst-case media loss, penalties, and receiver sensitivity.
- Laser power range may be tightened, depending on the laser power control circuit error, drift, aging, laser safety margin and calibration uncertainty.

Laser Bandwidth

- OC-48 Lasers performance is often encumbered by packaging parasitics.
- BW requirement diminished by half for PAM5 (encoded) relative to 10 GBaud (unencoded)
- BW Laser ~ 1.1 Baud in GHz = 5.5 GHz
- Higher production yield for lower BW lasers
- Lower packaging & integration costs for lower BW lasers

Laser Nonlinearity

- Causes of Nonlinearity in Laser Diodes
 - ◆ Threshold (easily avoided)
 - ◆ High-power limiting (VCSELS and detectors)
 - ◆ Dynamic self-heating effects (low-frequency)
 - Coding related: DC Balance, Scrambling, etc.
 - ◆ Overdrive or operation near resonance such as relaxation oscillation frequency
- Nonlinearity & distortion in drive electronics
- Kinks in the I-L curve

Nonlinearity Effects on the Link

- Large-signal effects such as threshold (I_{th}) and Rx saturation induce a duty cycle distortion.
 - ◆ Avoid (I_{th}) and don't saturate the receiver
- Power penalty due to eye closure
- 2nd, 3rd harmonic, sum & difference frequencies
- Easy for kink-free digital lasers to pass
 - ◆ Requirement for kink-free performance over temperature and operating range

Large and Small-Signal Nonlinearity

LD Gross Nonlinearity

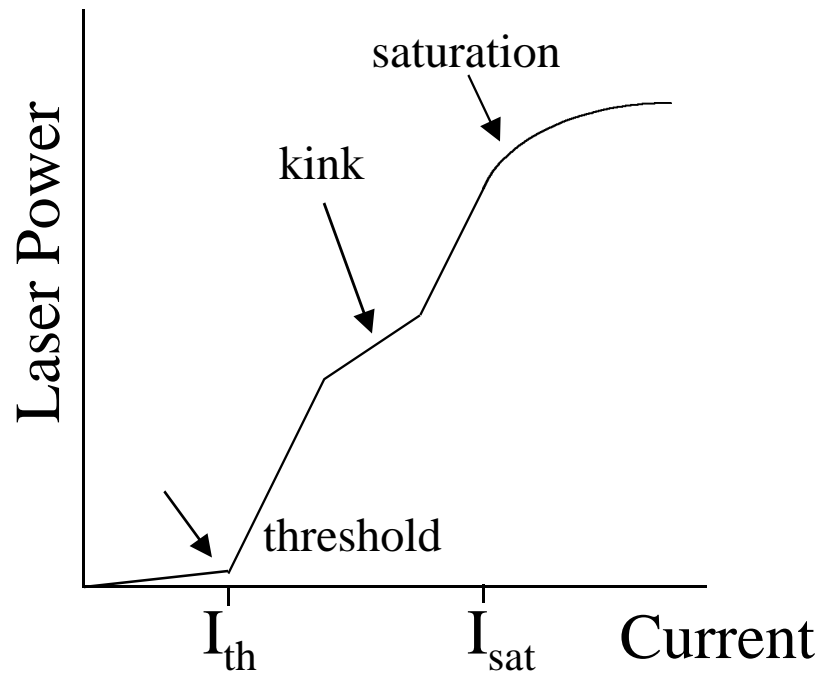

LD Small-Signal Nonlinearity

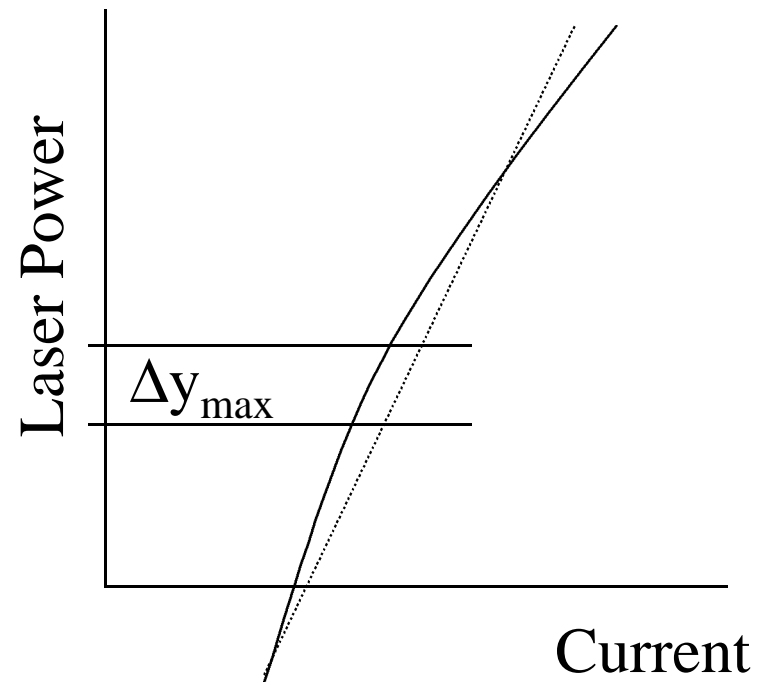

Linearity Compensation

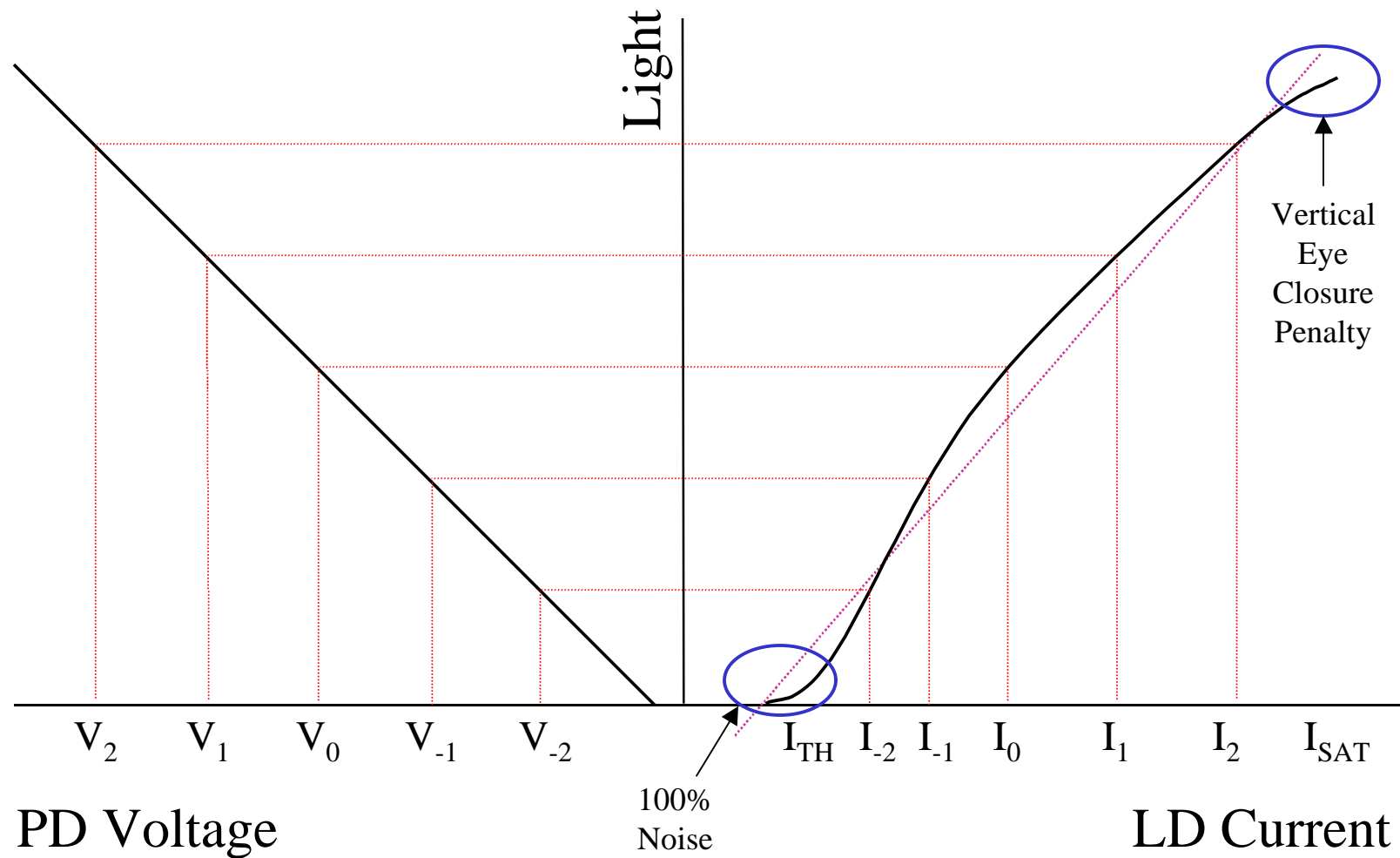

Linearity Experiment

- 2-tone testing
- System baseline > 90 dB not including PD
- PD & amplifier linearity > 70 dB below saturation
- 2 Vendor's digital 1300 nm DFB lasers
- Measured 3rd harmonic
 - ◆ over frequency (250 MHz - 4 GHz)
 - ◆ over power (0.25 mW - 2 mW)
 - ◆ over modulation index (0.05 - 0.5)
- Both devices were linear (> 40 dB)

2-Tone Testing

- 2nd-order: Measure ratio H of fundamental tone at f_1 to the intermodulation signal at $(f_2 - f_1)$
- 3rd-order: Measure ratio H of fundamental tone at f_1 to the intermodulation signal at $(2f_2 - f_1)$

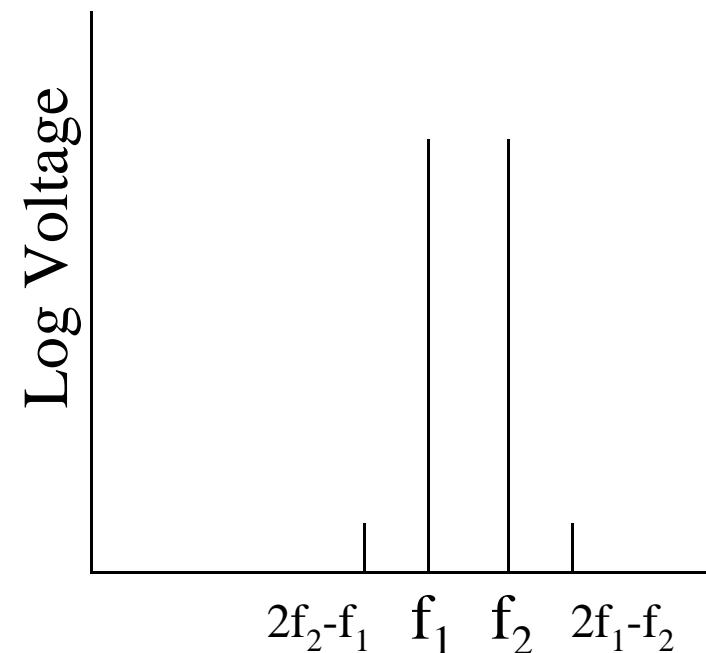
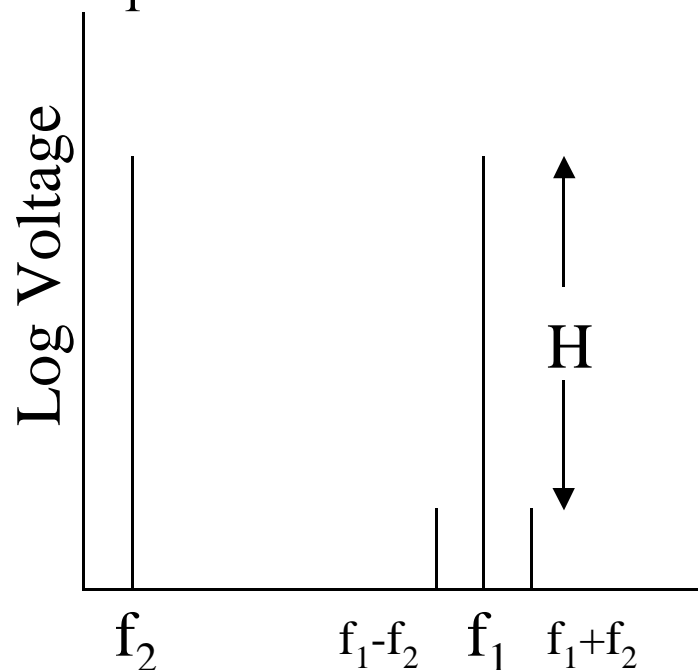

2-Tone Nonlinearity Test Setup

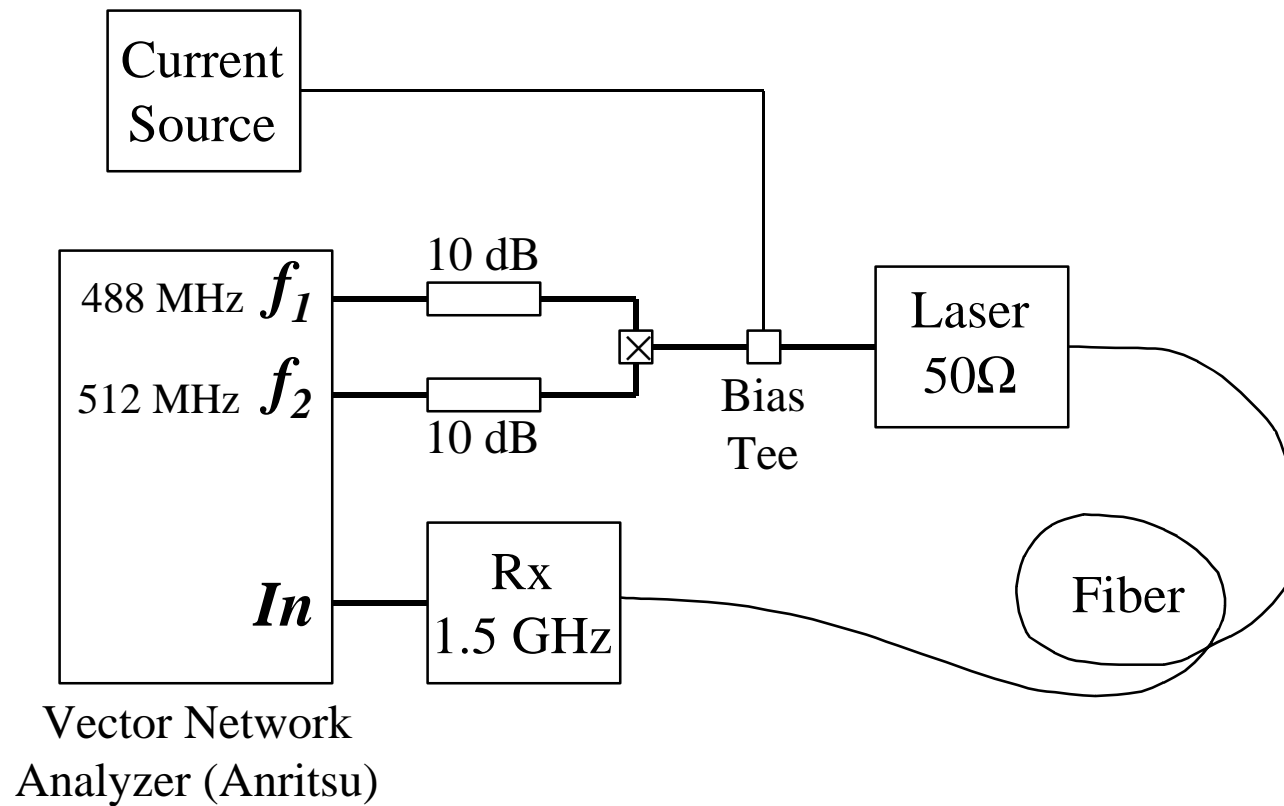

Time Domain Baseline

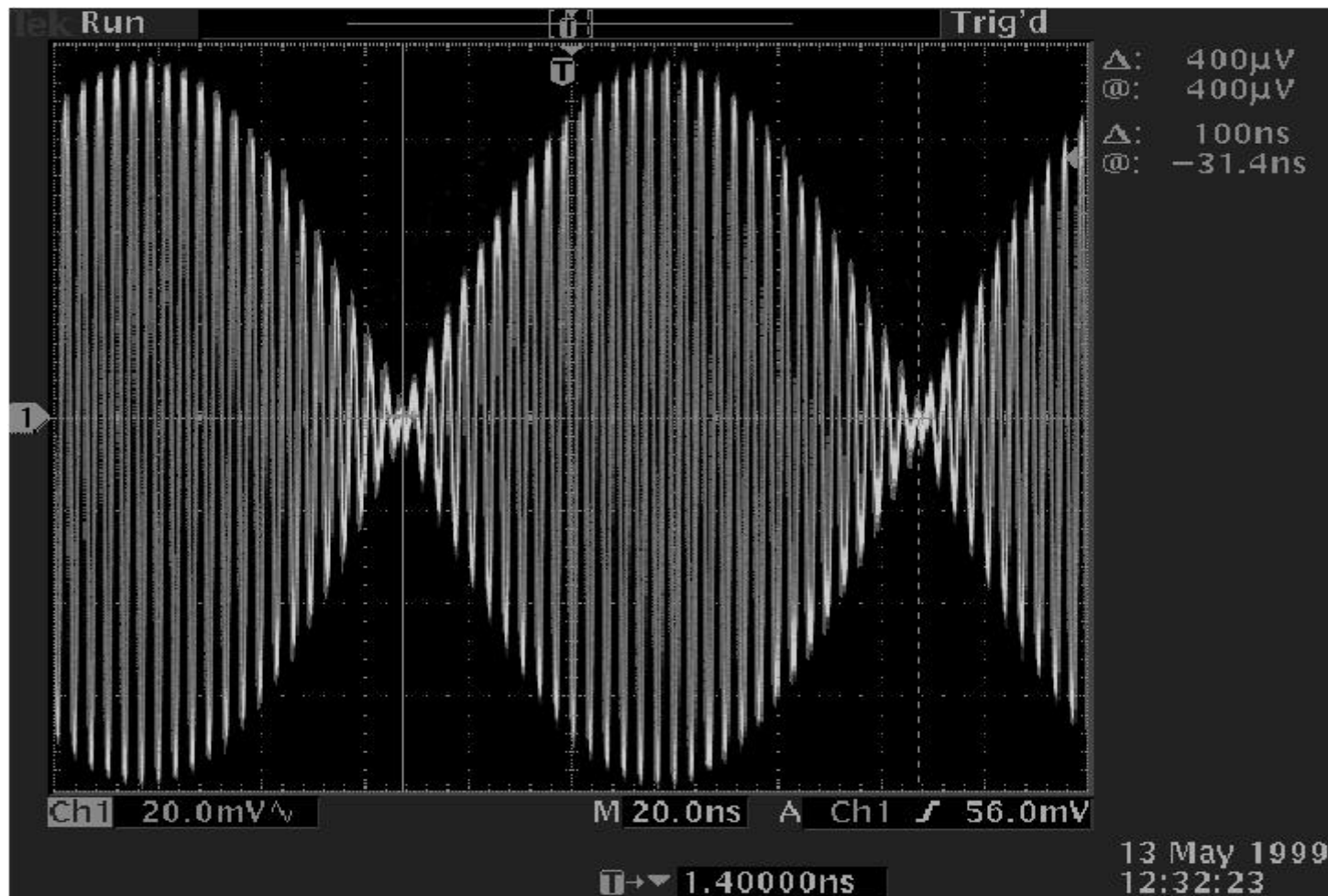

Frequency Domain Baseline

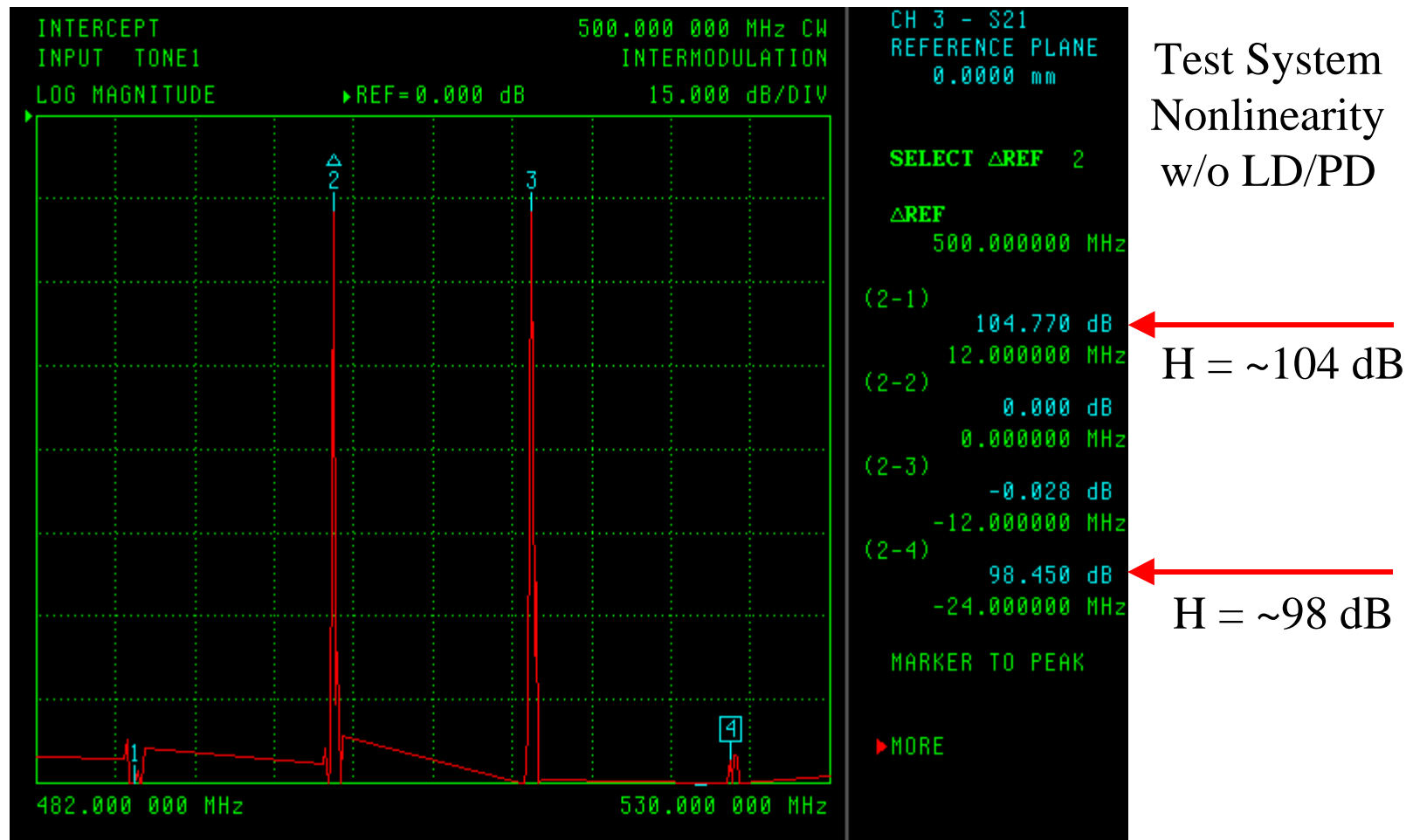

Vendor 1 Laser @ 1 mW

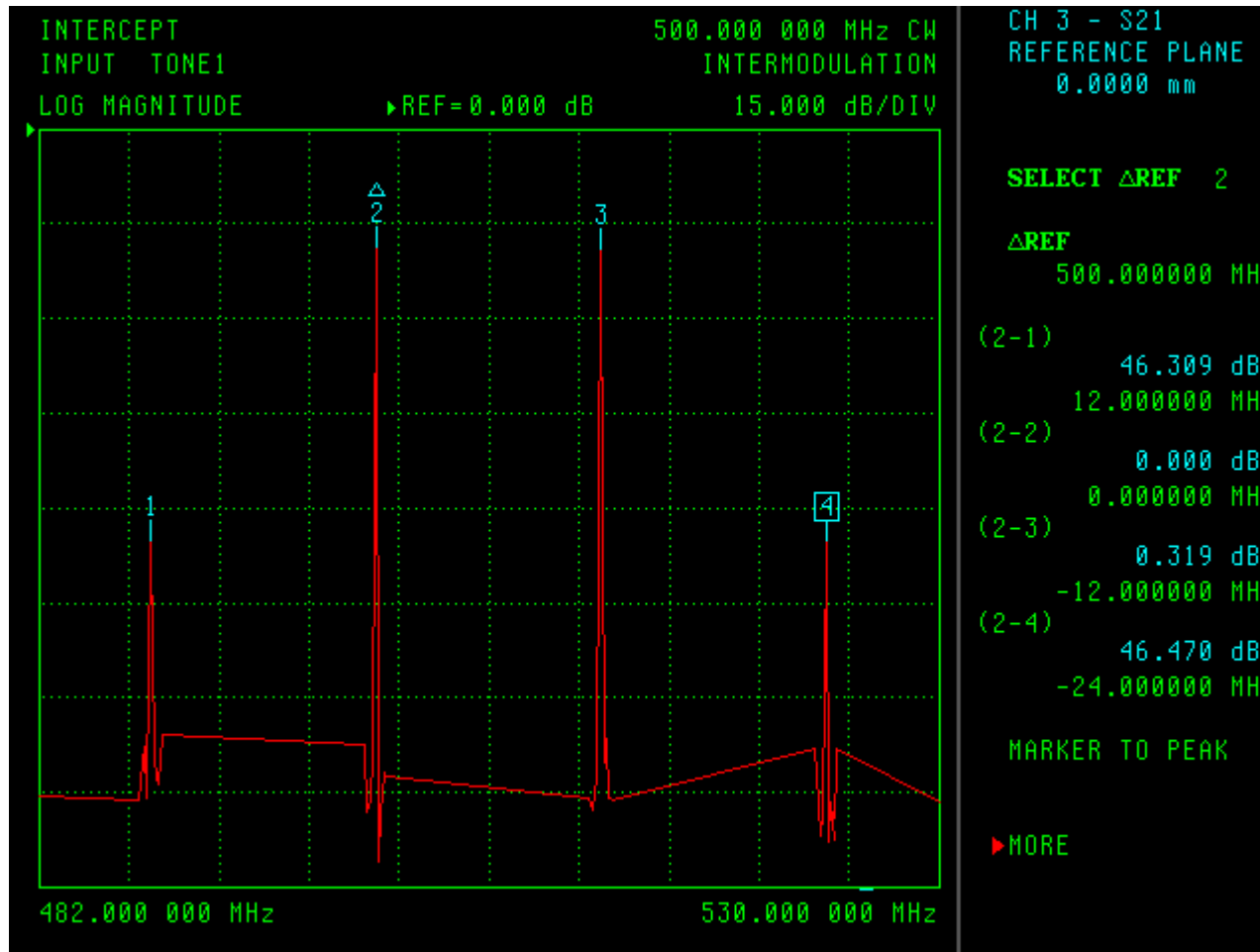

DFB Laser
1300 nm
Modulation
Index: 50%
Coax Package

H = ~46 dB

H = ~46 dB

Linearity Calculation

- Linear operation on function $X(t)$

$$Y(t) = A + B X(t)$$

X =input, Y =output, A = Y -intercept, B =slope

- Nonlinear operation

$$Y(t) = A + B X(t) + C X(t)^2 + D X(t)^3 + \dots$$

Assume non-linearity coefficients C and $D \ll 1$, neglect higher-order

- Error is $\Delta Y \approx C X(t)^2 + D X(t)^3$
- Maximum error is $E = (C/3)^3 / (D/2)^2$
- E.g. 1Ω Resistor: $A=0$, $B=1$ V/mA, $C=0.001$ V/mA², $D=0.001$ V/mA³, then $E=0.00067$ V

Requirements Calculation

- Consider the nonlinear transfer function

$$Y(t) = A + B X(t) + C X(t)^2 + D X(t)^3$$

Assume coefficients C and D $\ll 1$

- Let $X(t) = \cos(\omega_1 t) + \cos(\omega_2 t)$ this generates

$$Y(t) = A + B X(t) + (C/2)\cos(2\omega_1 t) +$$

$$(C/2)\cos(2\omega_2 t) + C \cos(\omega_1 - \omega_2)t +$$

$$C \cos(\omega_1 + \omega_2)t \quad \text{which are the 2nd-order terms}$$

- + $(D/4)\cos(3\omega_1 t) + (D/4)\cos(3\omega_2 t) +$

$$(3D/4)\cos(2\omega_1 - \omega_2)t + (3D/4)\cos(2\omega_1 + \omega_2)t +$$

$$(3D/4)\cos(2\omega_2 - \omega_1)t + (3D/4)\cos(2\omega_2 + \omega_1)t$$

which are the 3rd-order terms

Nonlinearity Characterization

- Laser vendors may specify the nonlinearity as:
 - ◆ Composite Second-Order (CATV)
 - ◆ Composite Triple-Beat (CATV)
 - Can relate CSO and CTB to the nonlinear coefficients C and D given the # of channels and intermodulation products/channel
 - ◆ 2-Tone test at the appropriate frequency is simpler
 - Use Vector Network Analyzer
 - For 2nd-order, 2-tone test, $C = H$
 - For 3rd-order, 2-tone test, $D \approx (4/3) H$
 - Assuming the coefficient $D \ll 1$
 - -20 dB requirement: $D = 0.013$, $C = 0.01$

Laser Linearity Summary

- Power penalty = $10 \log [1-(N-1)E]$
- Need linearity of -20 dB for <0.25 dB penalty
- Early analysis of a limited sample of standard digital (not CATV) OC-48 DFB class lasers indicate sufficient linearity performance.
- Kink-free lasers appear to be sufficient for MAS deployment.
- Large-signal linearity is a function of link design.
- Production testing for small-signal linearity may not be required.

Laser Noise

- RIN is a catch-all for Noise in a Laser Power
 - ◆ $RIN = \langle P^2 \rangle / \langle P \rangle^2 = \text{variance} / (\text{average})^2$
 - ◆ Back Reflections into the laser cavity can make noise very large and chaotic
 - ◆ Shot noise from quantum nature of photons and injected carriers (spontaneous emission)
 - ◆ Mixing of spontaneous emission with the lasing field
 - ◆ Thermal fluctuations
 - ◆ Mode-Partition noise, mostly in FP lasers, less problematic in DFB/DBR lasers

How to Reduce Laser Noise

- Reduce Line Rate and BW (MAS, scrambling)
- Implement FEC for coding gain to offset RIN
- Tighten RIN specification on lasers
 - ◆ For RIN-dominated systems, a 6 dB RIN decrease yields a 3 dB SNR improvement
- Optimize laser for low threshold, high carrier density and high relaxation oscillation frequency
- Cooling is not a cost-effective option
- Add an Optical Isolator

Optical Isolator

- An Isolator is a “check valve” for light
- Avoids Back Reflections from connectors
- Very compact device, easy to integrate
 - ◆ For a low-noise laser, an isolator preserves the intrinsic laser RIN in a system with large back reflections
- Cost is \ll 50% of a single DFB laser
- Small loss penalty < 0.5 dB
- Difficult to incorporate into multi-channel lasers
- Tradeoff Isolator cost against FEC silicon cost to achieve System BER Objective.
 - ◆ Suggested MAS Direction: Robust FEC

Optical Isolator Basics

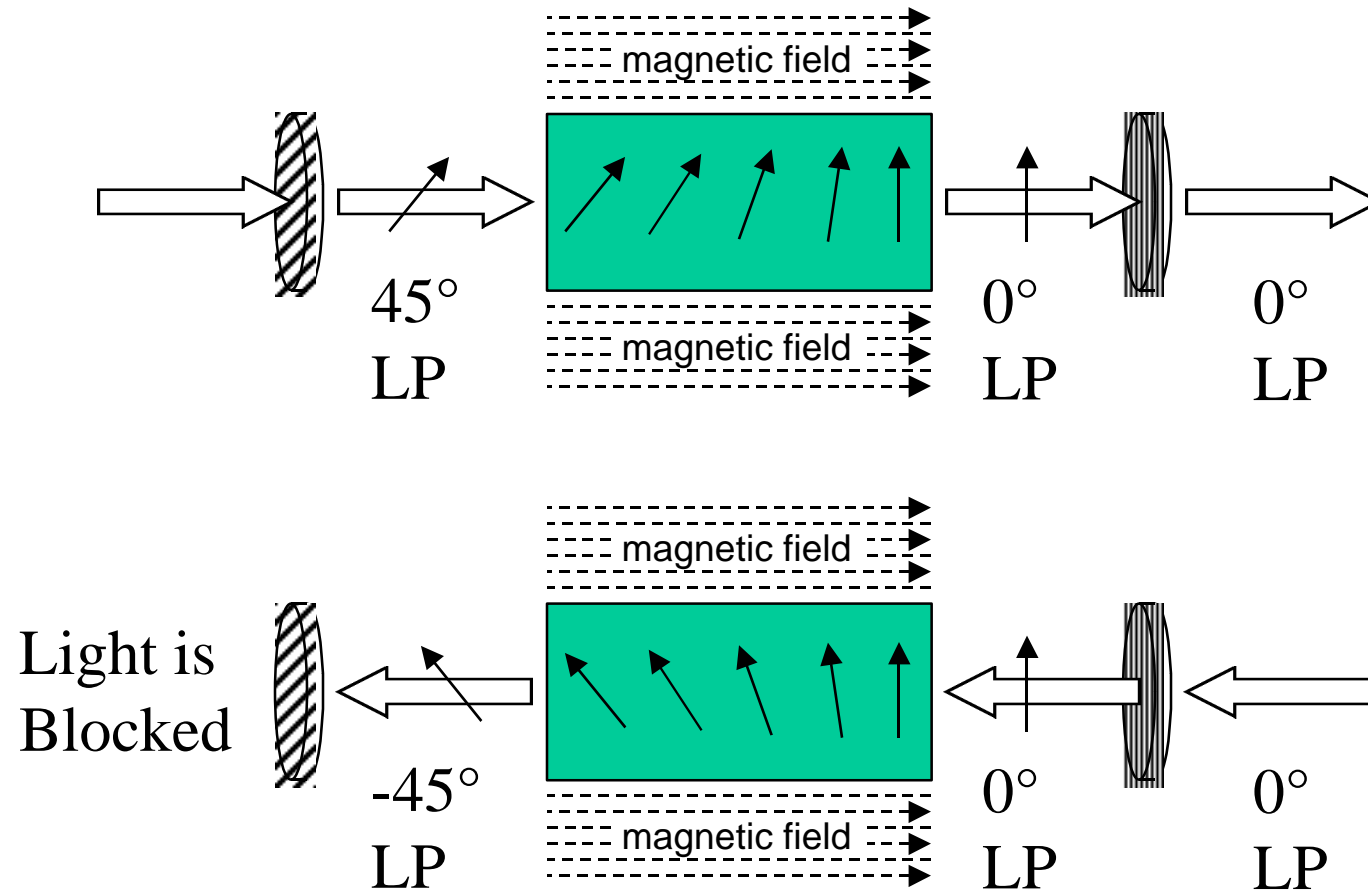

LD Example Requirements, LX

- OC-48 class DFB/DBR laser
- 1310 nm wavelength
- 1 mW average power
- Nominal Linearity (-20dB ~ -30dB)
- RIN better than -125 dB/Hz
 - ◆ Tradeoff against FEC complexity, Isolator cost
- 5.5 GHz Bandwidth (<65 pSec)
- Carrier, Die, or other HF packaging

Note: Work in progress, not Absolute Requirements

Optical Receiver Attributes

- Wavelength
- Optical Power
- Bandwidth
- Linearity
- Noise

Receiver Wavelength and Power

- Rx saturation level is set by the best-case responsivity, headroom in the photodetector biasing and subsequent amplification stages.
- Cannot use traditional limiting post-amp
 - ◆ Requires linear post-amp
- LW Receiver is more sensitive than SW
- Receiver noise can dominate ultimate sensitivity at low power levels.

Receiver Bandwidth

- BW requirement diminished by half for PAM5 (encoded) relative to 10 GBaud (unencoded)
- BW Receiver ~ 0.75 Baud in GHz = 4.0 GHz
- Integrated PhotoDiode (PD) and Trans-Impedance Amplifier (TIA) component availability is much higher @ 4.0 GHz than >7.5 GHz (10 GBaud)
- Higher production yield for lower BW devices
- Lower packaging & integration costs for lower BW devices

Receiver Linearity

- PDs are intrinsically very linear
- Avoid saturation and compression regimes
- Gain of TIA and postamp sets AC/DC saturation
- Care in design of Rx electronics yields low NL

Receiver Noise Components

- Shot Noise: $\propto \sqrt{BW}$ $\propto \sqrt{Power}$
- Thermal Noise: $\propto \sqrt{BW}$
- Dark Current Shot Noise: $\propto \sqrt{BW}$ $\propto \sqrt{I_{DARK}}$
- 1/f Noise: at low frequencies
- Amplifier Noise: design & component selection
- Power Supply Rejection Ratio: design & component selection
- Uncorrelated crosstalk and EMI Susceptibility: layout and shielding

Optical Sub-Assembly Packaging

- MAS PHY is OSA and connector independent
- Supports MMF & SMF installed and new media
- Duplex-SC and Small Form Factor Integration
- OSA package independence
 - ◆ Pigtailed HF packaging, e.g. mini-DIL
 - ◆ Traditional coaxial OSA's
 - ◆ V-groove, microbench, MT-type technology
- More flexibility for module implementation

MAS Optical Non-Issues

- Receiver Nonlinearity
- Sidemode Supression Ratio
- Laser Absolute Wavelength
- Laser Temperature Control
- Photodetector linearity
- Skew
- Crosstalk

Optical Power Penalties

- Power Penalties need to be carefully re-examined for MAS
 - ◆ DFB lasers not covered in GbE link model
 - ◆ Model must be normalized for higher data rates/Baud according to the number of PAM levels
 - ◆ PAM power penalty $P_N = 10\log(N-1)$
- New Power Penalties also applicable to OOK
 - ◆ Laser Chirp penalty, if any
 - ◆ Polarization Mode Dispersion (long distance SMF)

Conceptual Optical Power Budget

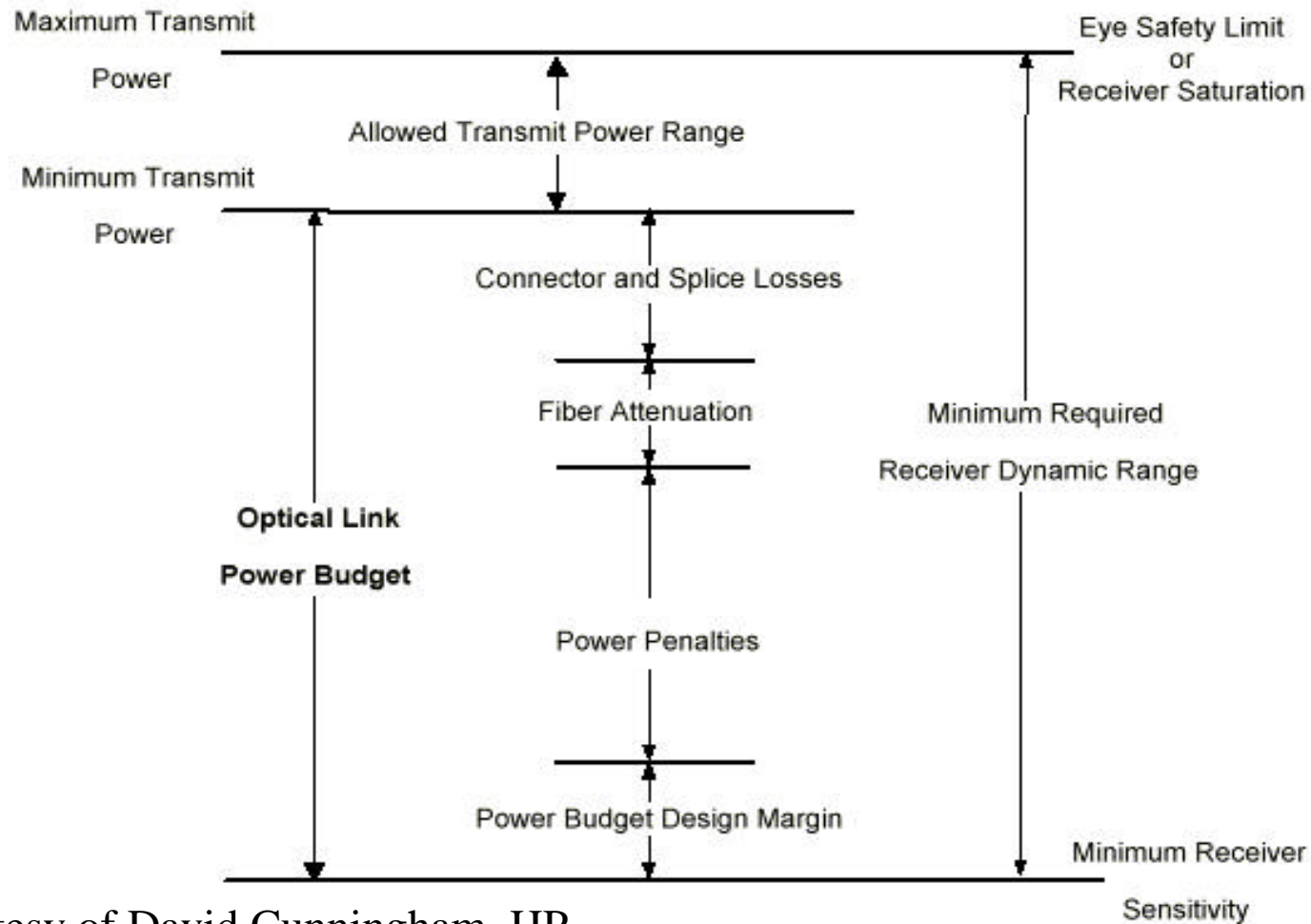

Courtesy of David Cunningham, HP

PMA - PAM5 Optical Power Penalty

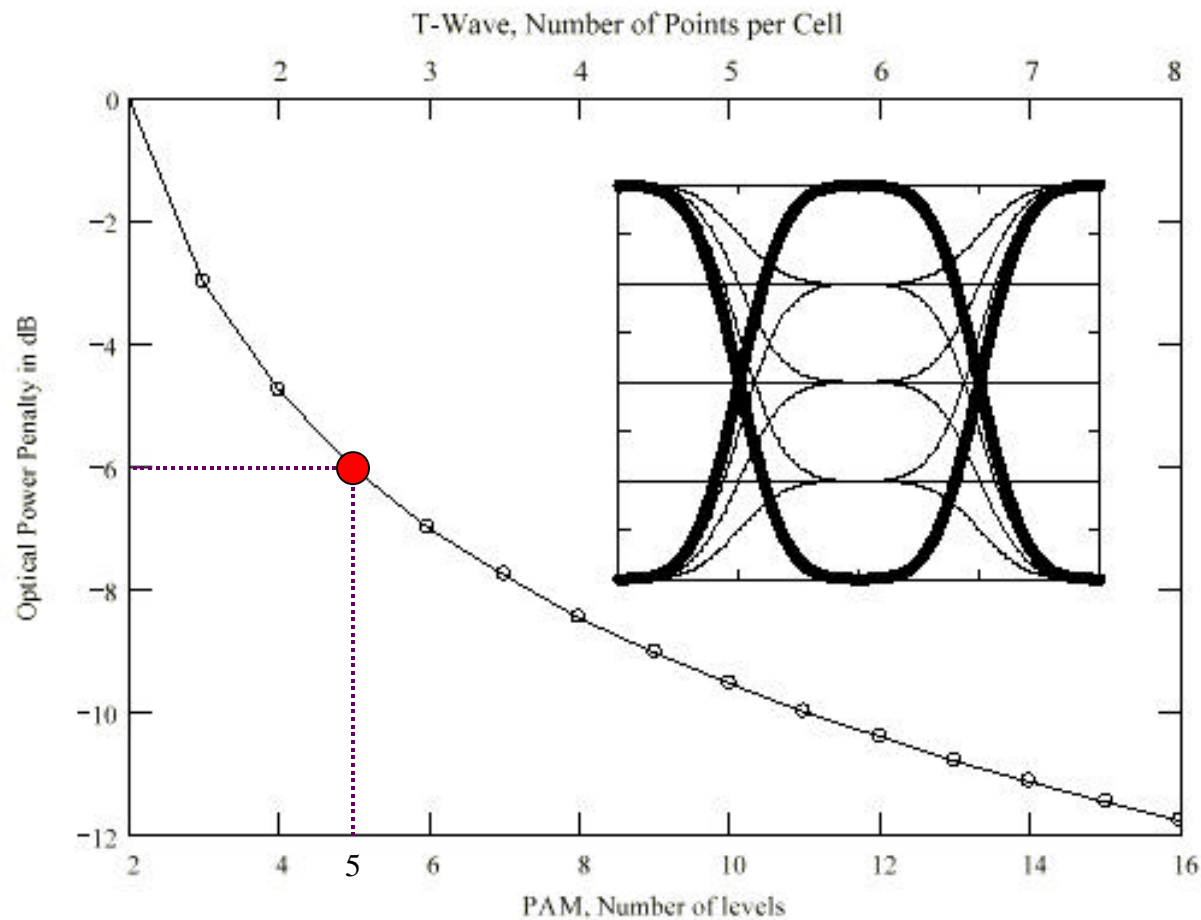

PAM5 penalty
6 dB

Note: Constant Symbol Rate Assumed

Courtesy of David Cunningham, HP

Beyond PAM5

- PAM5 significantly more cost effective than PAM2
 - ◆ FEC and Link Calibration offset PAM5 losses
 - ◆ Careful system design enables more PAM levels
 - ◆ For a 3 dB link penalty, PAM9, 3 bits/Baud, 3.33 GBaud, f_o 1.875 GHz, supporting MMF with 500 MHz•km/1.875 GHz \approx 267 m
 - Only 5.6% higher Baud than 3.125 GBaud
 - Enables simpler CDR, DAC, ADC designs
 - Enables simpler equalization designs, longer distances
- The technology to go beyond PAM 5 is here now

PCS - Coding

- PAM5 systems have coding requirements similar to those of PAM2 (e.g. GbE's 8B/10B) including:
 - ◆ Special Symbol support (SOP, EOP, etc.)
 - ◆ DC Balance (jitter containment)
 - ◆ Transition Density (CDR)
 - ◆ Error Containment (minimal error multiplication)
- PAM5 adds FEC to these requirements
 - ◆ Possible FEC codes include:
 - Trellis/Viterbi (e.g. 1000BASE-T)
 - Reed-Solomon
 - E.g. RS(255,239) code in 10^{-4} BER, out 10^{-14} BER

PAM5 Coding Direction

- One 1000BASE-T PCS octet maps to one symbol spread across 4 wire pairs (1 Baud interval).
- 10 GbE maps one 1000BASE-X equivalent octet to 4 consecutive Baud intervals.
 - ◆ PAM5 symbol = $5 \times 5 \times 5 \times 5 = 625$ code points
- 8B/10B supports 256 data codes, 12 special codes
 - ◆ 268 codes map to $\sim 400/1024$ total codes
- PAM5 goal is to map 625 code points to the 268 codes AND meet all other coding requirements including FEC.

FEC Coding Gain

- Redundancy is used by all Forward Error Correction (FEC) codes to perform Error Detection and Correction (EDAC).
- FEC codes allow a receiver in the system to perform EDAC without requesting a retransmission.
- FEC codes enable a system to achieve a high degree of data reliability, even in the presence of significant signal noise.
- FEC usage can offer significant effective SNR improvement in systems where improvement using any other means is very costly or impractical.
 - ◆ E.g. Increased transmit power, expensive lower noise components.
- FEC SNR improvement is sometimes called “coding gain”.

FEC Latency

- Worst case: A long block length Reed Solomon code, such as (255,239)
 - ◆ 255 bytes @ 100 ps/bit = 204 nsec @ 10 Gbps
 - ◆ Light travels through a fiber at a rate of ~5 ns/m
 - ◆ $204 \text{ ns} / (5 \text{ ns/m}) = 40.8 \text{ m}$ of fiber optic cable
 - ◆ Actual delay depends heavily upon the particular implementation (e.g. degree of parallelism, hardware vs. tables vs. firmware, etc.)
 - ◆ Negligible latency effects on full duplex links
 - ◆ SNR/BER gain of FEC vs. additional gates/latency is a good tradeoff

MAS PMD

- PMD independent, supports SX, LX, EX, CX
- Supports the same media as 1000BASE-X
- Supports similar distances as 1000BASE-X
 - ◆ 62.5 μm MMF, 500 MHz•km, 1300 nm \approx 200 m
 - ◆ 50 μm MMF, 1250 MHz•km LOF, 1300 nm \approx 500 m
 - ◆ Even longer distances @ 850 nm with VCSELs and newer enhanced MMF, 2200 MHz•km \approx 880 m
 - ◆ SMF 1300 nm \approx 10-15 km

Auto-Negotiation (AN)

- Unrelated to MAS technology, distinct protocol
- Simplifies the 1/10 GbE integration task
- Uses Tone-based signaling akin to FLPs
 - ◆ New AN protocol for optical/copper serial links
 - ◆ Enables speed negotiation: 1/10 GbE operation
- Provides transport for MAS Link Calibration
- Leverages all of Ethernet AN except new Tones
- Achieves functional parity with UTP AN products
- Operational Benefit: Most useful to determine why two connected devices don't work

Auto-Negotiation Review

- Method used to exchange information between 2 stations;
- Used to configure operating parameters such as speed, flow control;

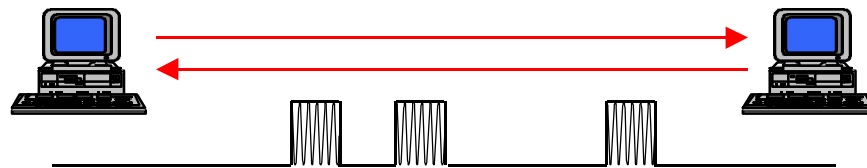

- An AN device advertises its abilities and detects the abilities of its Link Partner (remote device);
- AN information is exchanged using link pulses and acknowledged;
- AN compares the two sets of abilities and uses a priority resolution algorithm to establish the best mode of operation;
- The highest performance common technology is attached to the media;
- AN becomes transparent until reinvoked due to reset, power-on, link failure, etc.;
- Allows for automatic link establishment without user intervention.

Toning

- Serial Receivers include two receive circuits
 - 1) Data Acquisition logic
 - 2) Signal Detect logic
- Data Acquisition logic limitations
 - ◆ Frequency response limitations
 - Prevents direct communication between 1X and 10X variants
- Signal Detect logic may be used to detect Tones
 - ◆ Tones may be used between 1× and 10× variants
- Existence Proof
 - ◆ P1394b startup protocol
- Use Toning as basis for Serial AN Signaling

Tone Frequency



- Should support 1X - 10X or greater speed variants
 - ◆ Example Frequency: 625 MHz square wave
 - b'1010101010/0101010101' 8B/10B D21.5 code @ 1X speed
 - b'1100110011/0011001100' 8B/10B D24.3 code @ 2X speed
 - b'1100000111/0011111000' 8B/10B K28.7 code @ $\geq 4X$ speed
- Probably invisible to interfaces less than 1 GbE
 - Tone frequency above Fast Ethernet & Ethernet filters
 - Propose that lower speed Ethernet variants are not interoperable
 - If AN is supported by only one link end, and AN fails, it is assumed that the link partner is a 1GbE device

Tone Pulse Timing

- Tone Pulses correspond to Fast Link Pulses (FLP)
- Pulse Timing basis is Signal Detect response

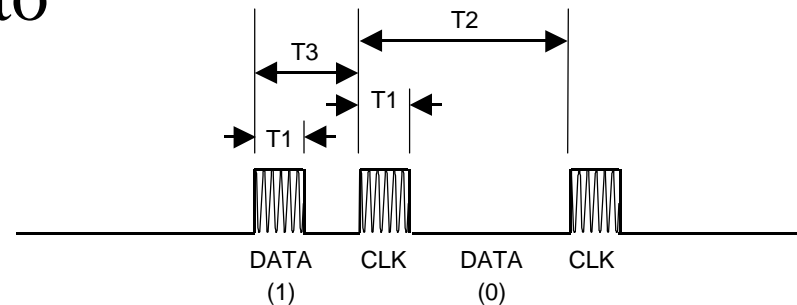

- ◆ Specs may be derived from GBIC, GbE, P1394b
- ◆ Transmit Disable pulsing possible, extends AN time
- Proposed Pulse and Pulse-to-Pulse timings
 - ◆ T1 - Pulse Duration: 50 μ s
 - ◆ T2 - Clock-to-Clock/Data-to-Data Duration: 200 μ s
 - ◆ T3 - Clock-to-Data/Data-to-Clock Duration: 100 μ s

Tone Pulse/Burst Protocol

- Tone Pulses are arranged 17-33 Pulses to a Burst
- Tone Bursts are transmitted repeatedly until ACK'd by Link Partner
- Tone Burst Protocol includes Base Page and Optional Next Page Exchange
- Priority Resolution algorithm establishes best mode of operation
 - ◆ The highest performance common technology is enabled
 - or
 - ◆ Management can tell why the 2 devices don't work

Link Calibration

- Uses information in Tone Pulses sent during AN to calibrate transmitter power and receiver levels
 - ◆ Executes simultaneously with AN protocol
 - ◆ Sets optimum transmit power for each link
 - ◆ Sets optimum receiver thresholds
 - ◆ Increases optical link budget
 - ◆ Eliminates optical compression penalty
 - ◆ Compensates for laser non-linearity
 - ◆ Similar in nature to, but much simpler than 1000BASE-T PHY-Startup

MAS Summary

- Digital grade lasers have sufficient linearity
- Provides two more variables, Baud & Number of Intensity Levels, for system tradeoff
- Is independent of PMD choices
- Scalable to even higher data rates

Acknowledgements

- The rest of the Transcendata design team
 - ◆ Isaac Achler, Greg Blanck, Fred Buckley, Eric Edwards, Bill Ellersick, Peter Gunadi, Prof. Joseph Kahn, Mike Wincn
- IEEE members who have directly/indirectly contributed
 - ◆ Dr. Kameran Azadet, Lucent; Brad Booth, Level One; Ben Brown, Nortel; Ed Chang, Unisys; Po Chiu, Fujitsu; David Cunningham, HP; Piers Dawe, HP; Howard Frazier, Cisco; Tom Hansen, AHA; Larry Rubin, Level One.
 - ◆ Note that the inclusion of any material from external sources does not denote the endorsement of MAS technology by the source individual and/or company.