

Mechanical Performance of Silica Clad Fiber in the 3M Galaxy Connector

Thomas Hanson
Standards Engineering Manager/Engineering Associate
Corning Incorporated
(607) 974-4530



CORNING

March 1997

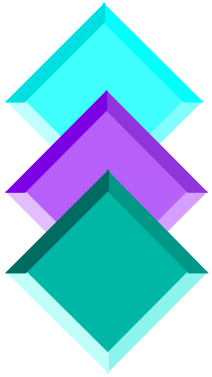

Outline

- ◆ Review the design of the 3M connector
- ◆ Discuss impact of connector mechanical requirements on reliability of fiber
- ◆ Determine failure probability of connector based on direct strength measurements
 - as manufactured strength
 - normal field usage wear
 - Failure probability analysis does not take into account extraneous damage due to unforeseen events
 - Dig ups, rodents, non-standard operating procedures, etc.

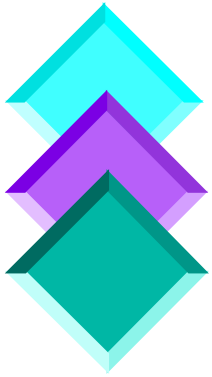

3M Galaxy Interconnect - Observations

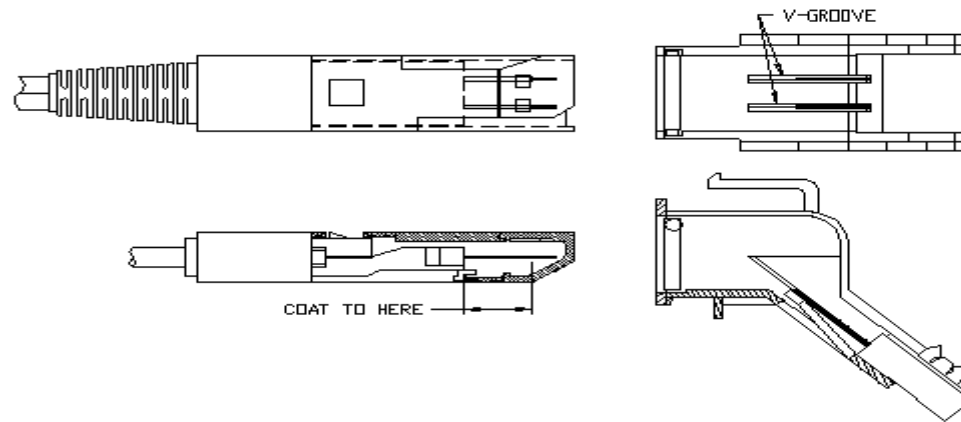

- ◆ Connector is composed of male/female (plug/socket) components prepared in a manufacturing facility
- ◆ Fiber held in connector by clamping mechanisms, assume tensile strain relieved by design
- ◆ Terminated acrylate coated fiber ends extend within plug
- ◆ Approximately 1 cm of fiber end is bare (i.e. acrylate coating has been removed)
- ◆ Plug un-coated fiber ends are contained within a protective shroud

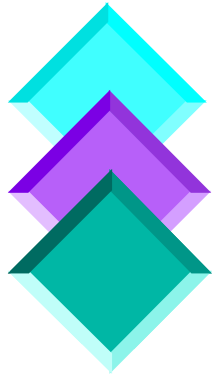

3M Galaxy Interconnect - Observations

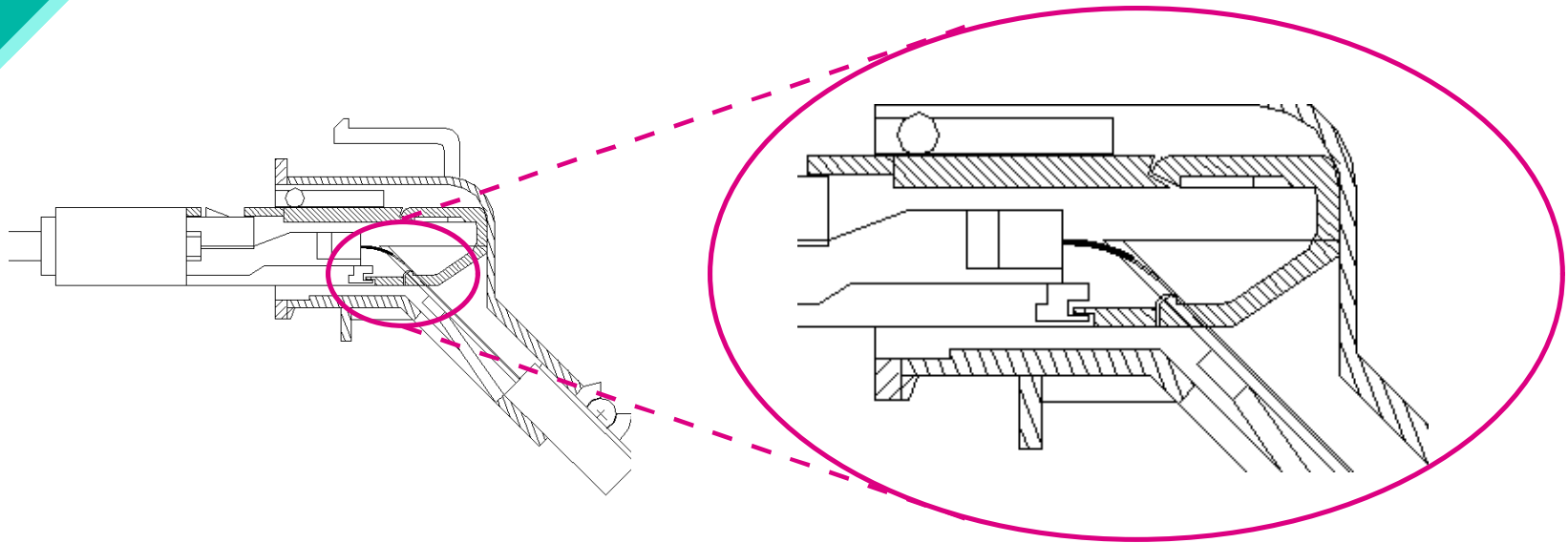

- ◆ When plug and socket are mated a portion of **coated** fiber is placed into a permanent bend, quarter turn (0.25) at 10 mm radius
- ◆ Bare plug fiber end is aligned in the socket by direct physical contact with guide groove
- ◆ Bare fiber experiences a static bend condition of ~63 mm radius, < 0.05 turn
- ◆ For 3M interconnect there is a customer concern over the use of bare fiber
 - Repeated interconnects may abrade fiber surface, lead to wear out over time
- ◆ **What is the mechanical performance of standard fiber?**

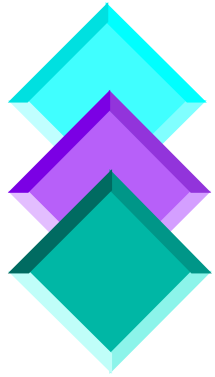

Factors Affecting Mechanical Reliability of Fiber

125 μm Fiber
Silica Clad

- ◆ Strength of the fiber
 - Size and distribution of flaws on the fiber surface
 - Determined by manufacturing and Handling history
- ◆ Fatigue characteristics of the fiber
 - How the flaws will grow over time in the presence of moisture and applied stress
- ◆ Applied stress on the fiber
 - Tensile
 - Bending

Maximum Applied Stress on Fiber in Bending

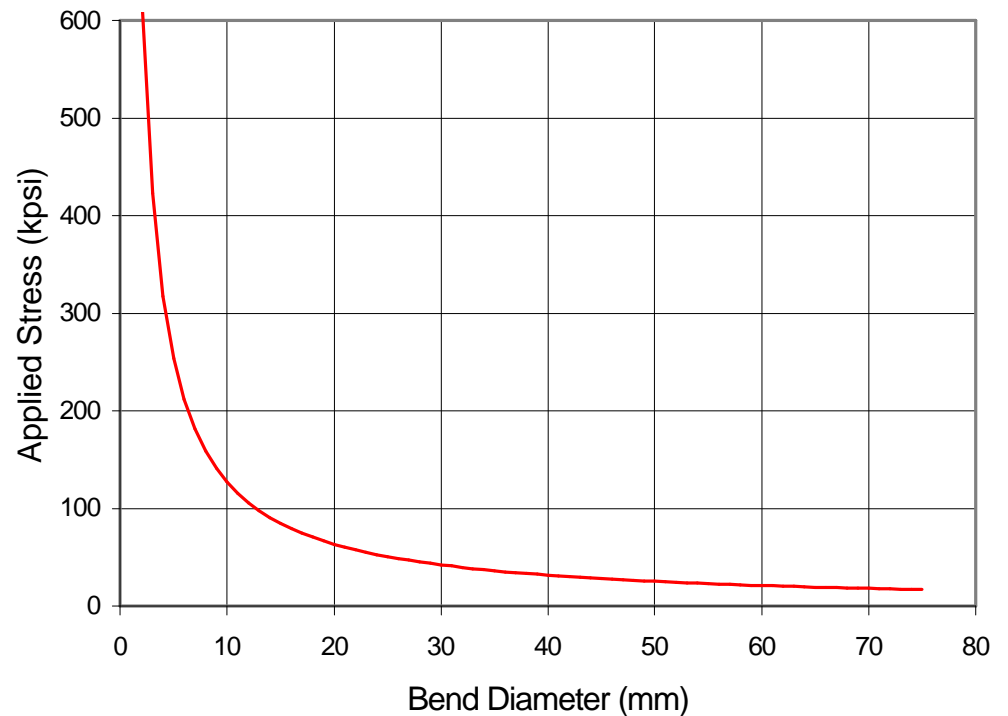

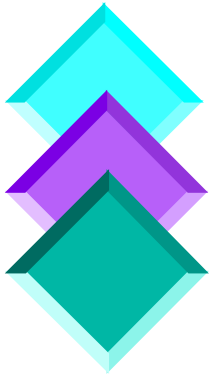

Low Strength Distribution of Silica-Clad Fiber - 822 km tested

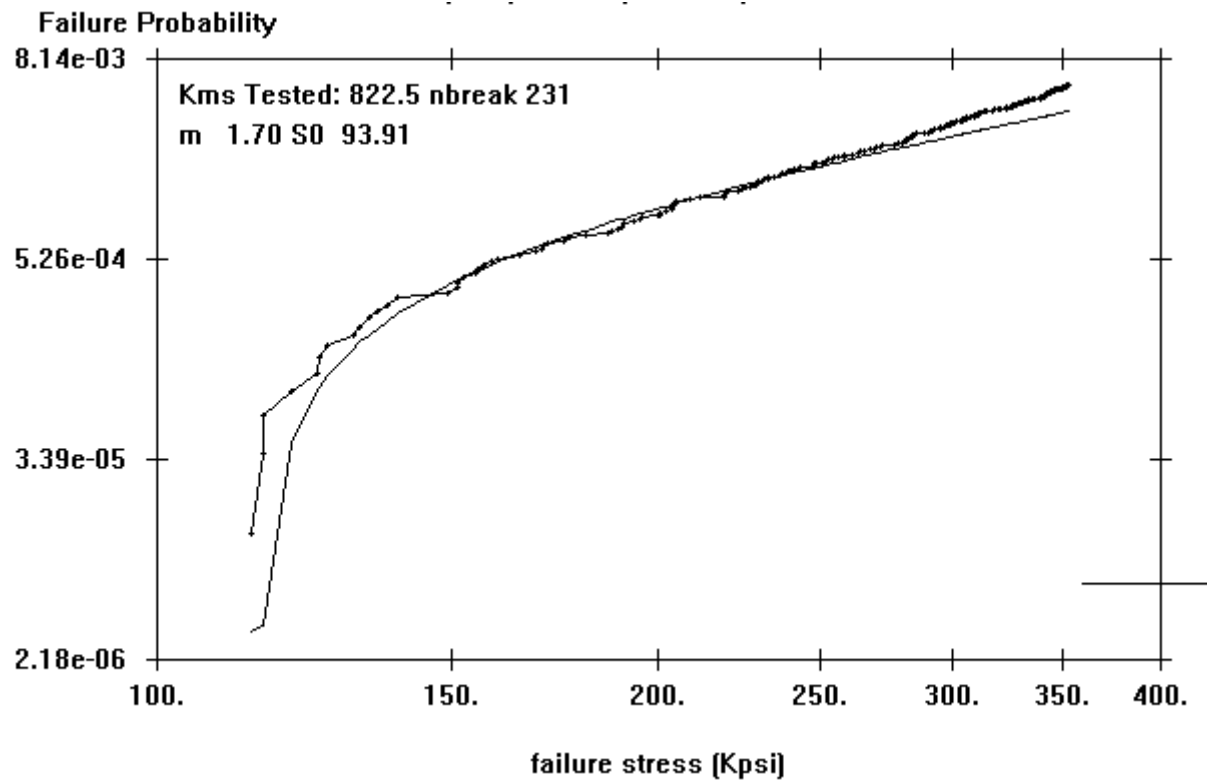

- ◆ Strength distribution of coated fiber
- ◆ Represents the low strength distribution of fiber that experiences 10 mm bend in the connector



CORNING

March 1997

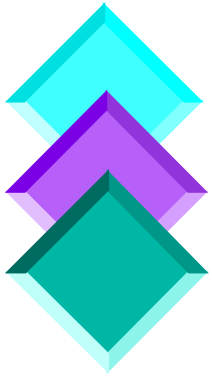

Failure Rate of Coated Silica Clad Fiber in 1/4 Turn Bend - 20 year life

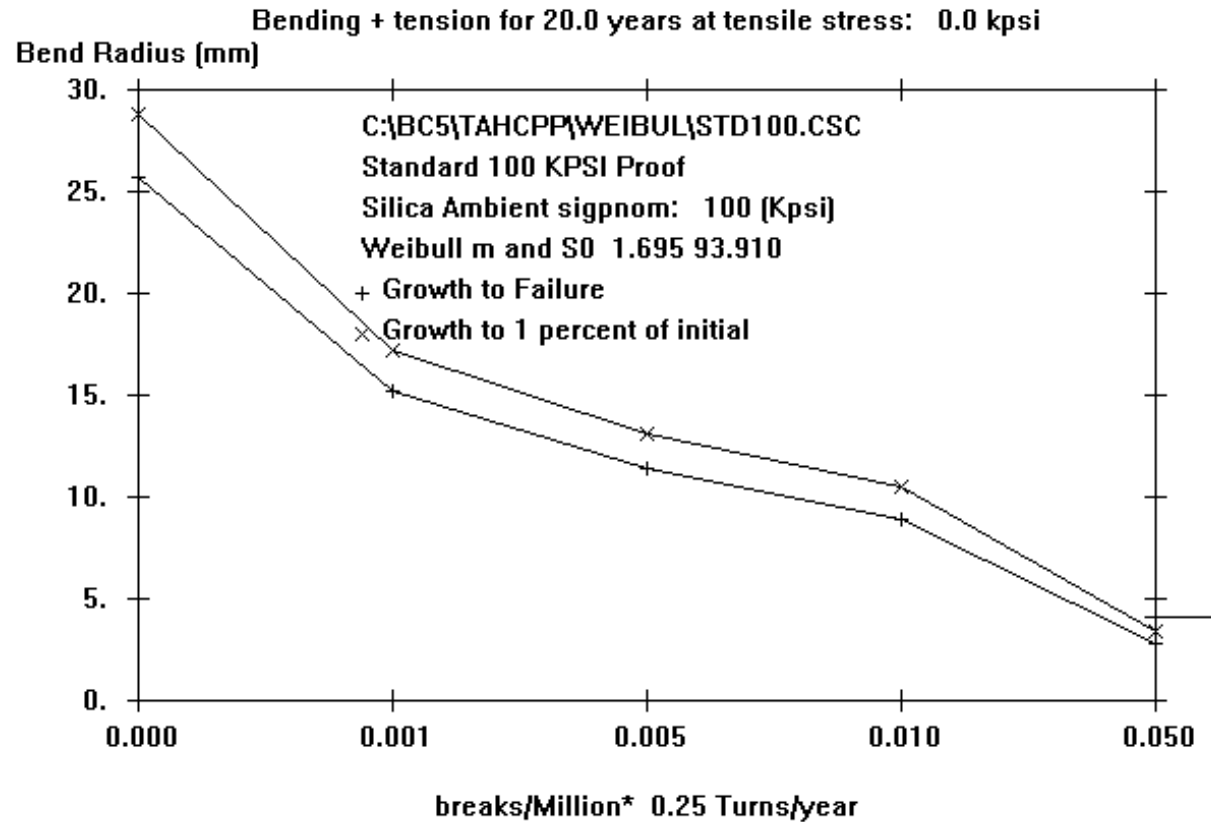

- ◆ For 10 mm bend radius, 0.01 ppm failures per year for 20 years



CORNING

March 1997

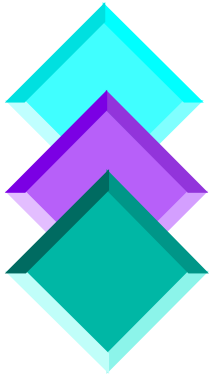

Measuring the Strength of the Bare Fiber Section

- ◆ Must determine the strength (distribution of flaws) of the bare fiber within the connector
 - As-manufactured strength of terminated fiber
 - Strength of terminated fibers after repeated connections
- ◆ 3M Role
 - Assemble sample connectors
 - silica-clad fiber terminated in plug (as manufactured)
 - silica-clad fiber terminated in plug and cycled through 500 interconnections
- ◆ Corning Role
 - Perform strength testing on the samples
 - Measure the strength of the fiber within the plastic shroud of the interconnect plug
 - Analyze data
 - Reliability modeling



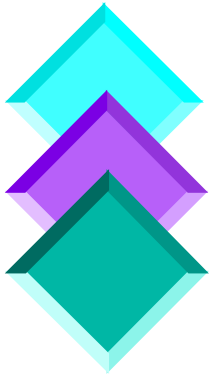

Connector Test Fixture

◆ Test Steps

- disassemble Plug
- clamp plug in place
- lower epoxy bead on to fiber
- allow epoxy to cure
- initiate test - record load at failure
- epoxy second fiber
- initiate second test - record load at failure
- unclamp plug

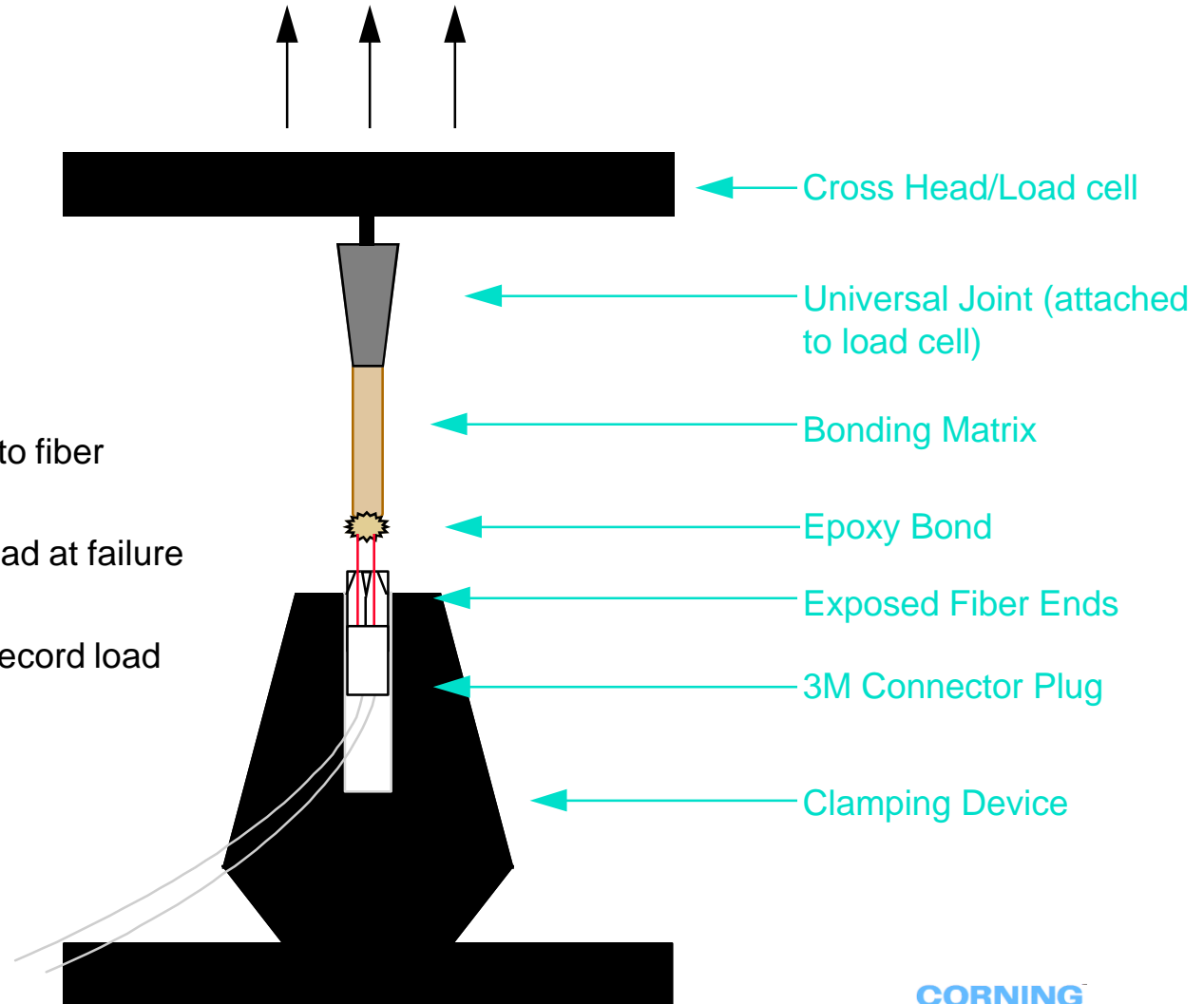

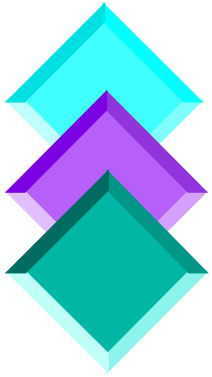

3M Interconnect - Strength Test Results with Corning Silica Clad Fiber

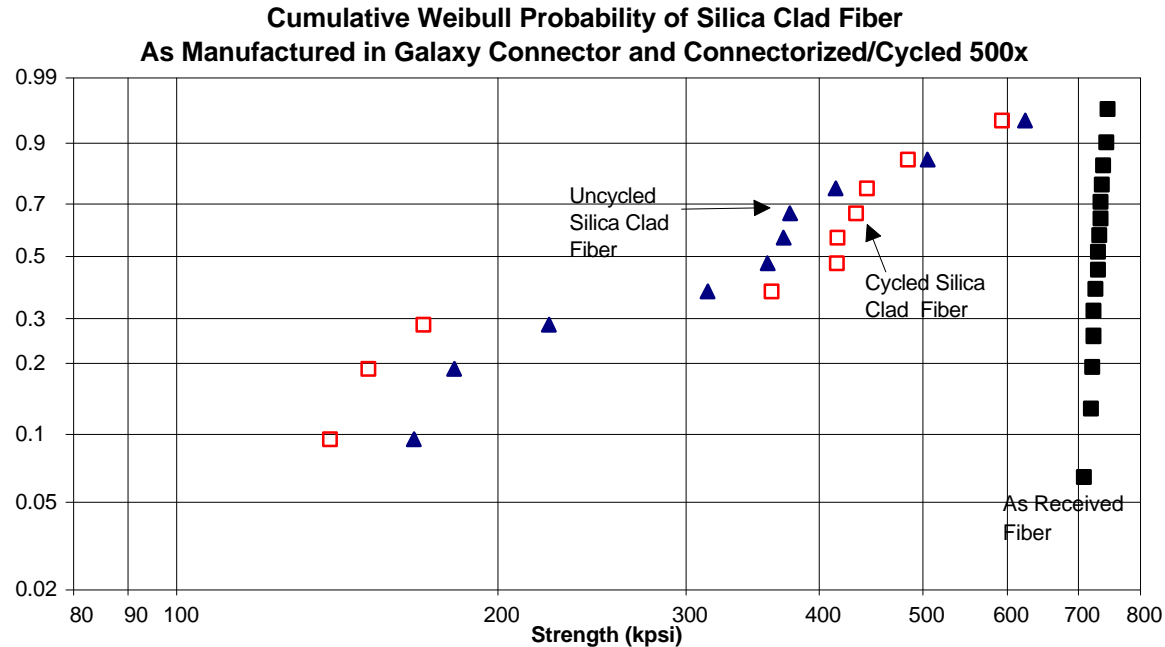

- ◆ Degradation in strength from as-received is observed, and expected for any silica clad fiber, Multimode or Single-mode
- ◆ Repeated mating of the connector does not change the strength distribution of the fiber



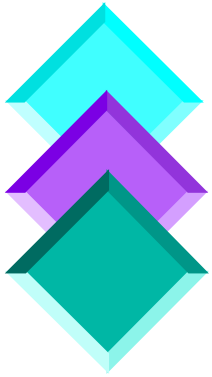

Mechanically Stripped Fiber

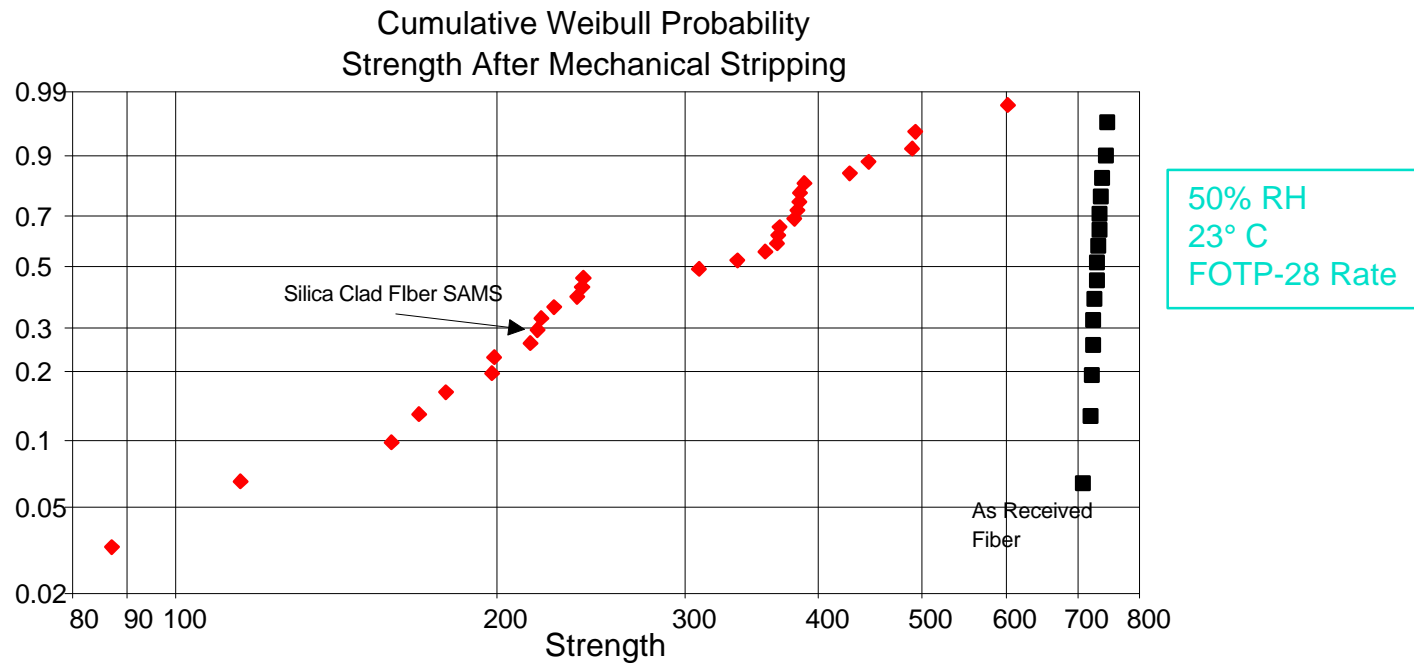

- ◆ Strength distribution of standard silica-clad fiber after mechanical stripping (Miller stripping tool)

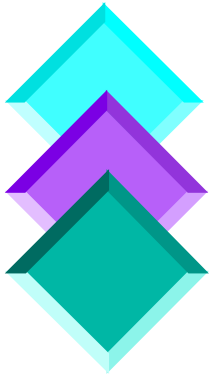

SAMS Data Compared to Corning Silica Clad Fiber

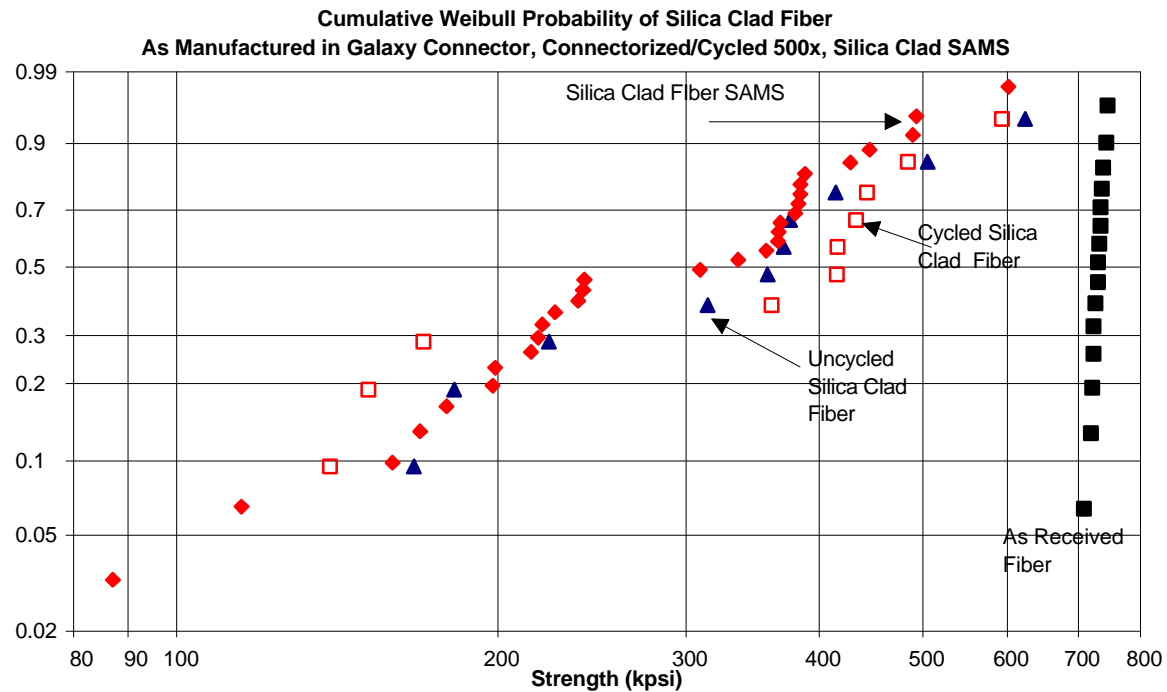

- ◆ SAMS: Strength After Mechanical Stripping
- ◆ The strength distribution of laboratory mechanically stripped fiber overlaps that of the terminated fiber
 - Any strength degradation is similar to common field termination techniques
 - 3M connector fiber strength is not significantly different than fiber in standard connectors



CORNING

March 1997

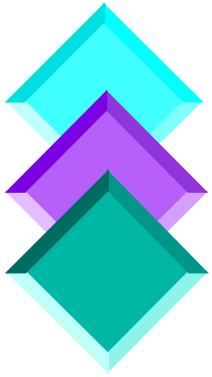

Failure Rate of Uncoated Silica Clad Fiber in Galaxy Connector

Failure Rate of Bare Silica Clad Fiber in 3M Galaxy Connector

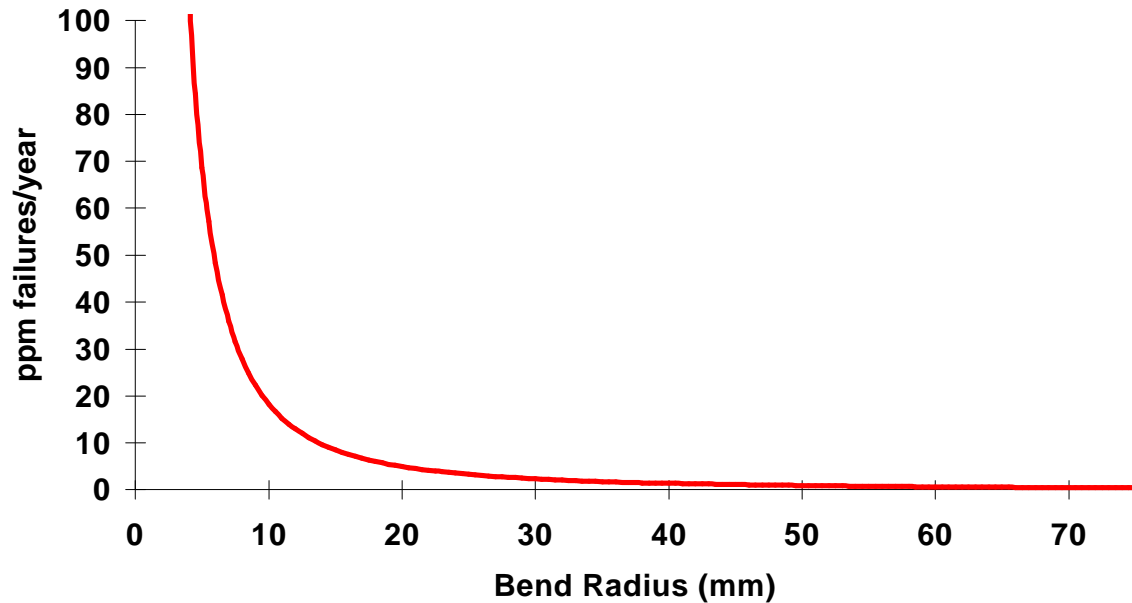

- ◆ Using technique applied to the coated section of fiber under bend the failure rate was determined for the bare fiber section before and after cycling
- ◆ Failure probability for 20 year life of the bare fiber within the connector was calculated to be < 10 ppm

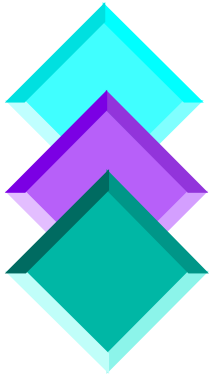

Conclusions

- ◆ The 3M Galaxy Interconnect design is a novel approach to low cost connectorization
- ◆ Fiber strength distribution in the connector is due to limited stripping of the coating
- ◆ No additional damage seen after repeated (500) connector re-mating
- ◆ Data and analysis indicate excellent reliability (<10 ppm failures) over 20 years for standard silica clad fiber (both MM & SM)



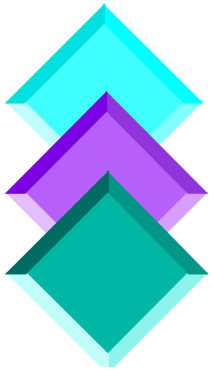

Aging of Abraded Silica Clad Fiber in 80°C Water

