**10GBASE-CR1 Study Group
Call-For-Interest
IEEE 802.3 Working Group
San Francisco, CA
July 2009**

Chris DiMinico
MC Communications
cdiminico@ieee.org

CFI meeting objectives

- To measure the interest in starting a study group for 10GBASE-CR1, a low-cost physical layer copper option for 10 Gigabit Ethernet.
- We don't need to
 - Fully explore the problem
 - Debate strengths and weaknesses of solutions
 - Choose any one solution
 - Create PAR or five criteria
 - Create a standard or specification
- Anyone in the room may speak / vote
- **RESPECT**... give it, get it

Study group activities

- Develop
 - Objectives
 - 5 Criteria responses
 - Project Authorization Request (PAR)

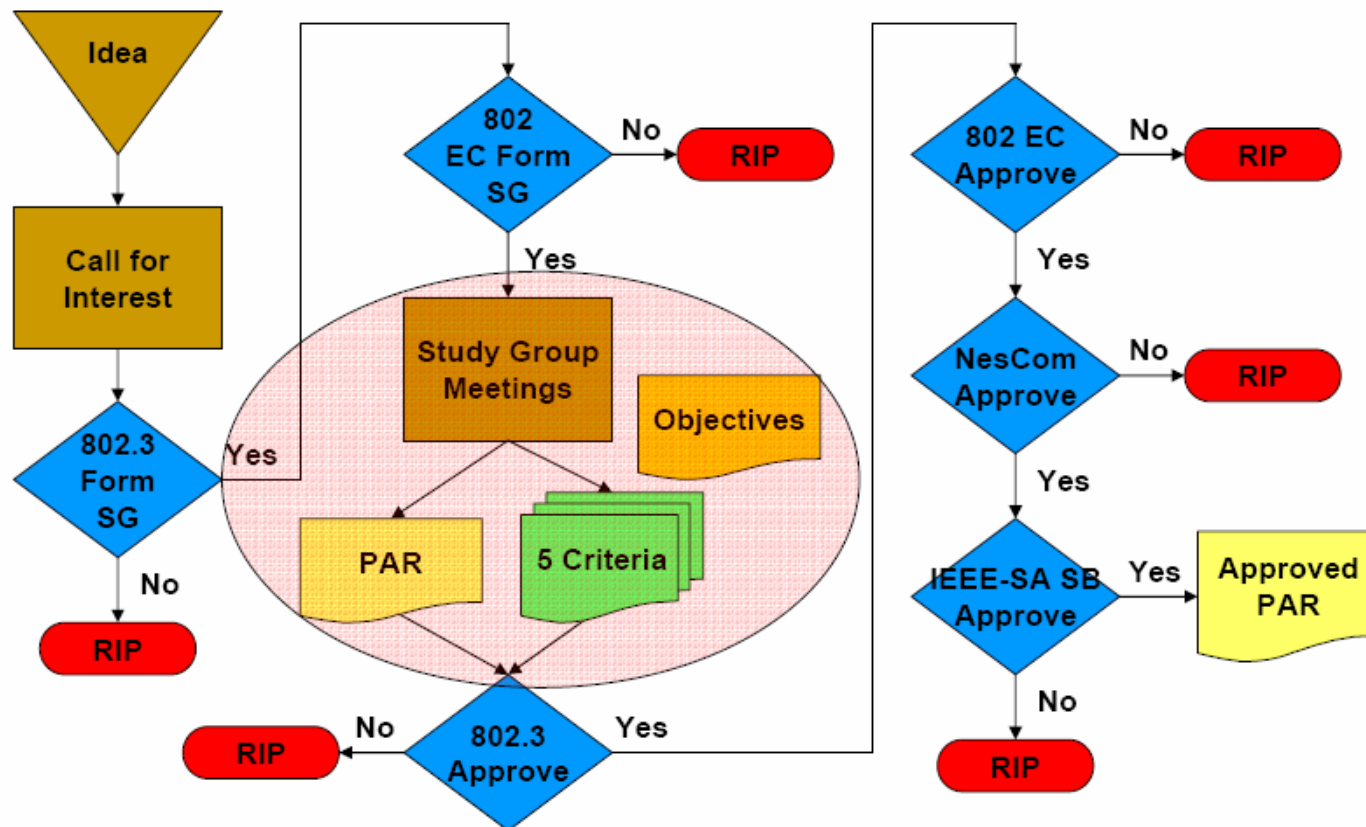

Potential study group items

- **Consider industry available specifications**
 - **40GBASE-CR4/100GBASE-CR10 (Clause 85) electricals and channel to specify 10GBASE-CR1**
 - **SFF-8431**
- **Consider smaller form factor MDI (smaller than SFP)**
- **Support IEEE P802.3az, Energy Efficient Ethernet**
- **Compatibility with SFI hosts**
 - **Supportable copper reach (CR1 host ← → SFI host)**

Supporters

- **Michael Bennett - Lawrence Berkeley National Laboratory**
- **Chris DiMinico - MC Communications**
- **Galen Fromm, Jay Neer - Molex**
- **Rita Horner, Brian Misek - Avago Technologies**
- **Ryan Latchman - Gennum Corporation**
- **Greg McSorley - Amphenol**
- **Shimon Muller - Sun Microsystems**
- **Gourgen Oganessyan - Quellan Inc.**
- **Robert Winter - Dell, Inc.**
- **Ilango Ganga, David Chalupsky, Rich Mellitz - Intel**
- **George Zimmerman - Solarflare**
- **Dan Dove - HP ProCurve**
- **Jim McGrath - Cinch Connectors**
- **Nathan Tracy - Tyco**
- **Ron Nordin - Panduit**
- **Atul Sharma - Volex**
- **Rick Rabinovich - Alcatel-Lucent**
- **Henning Hansen - LEONI Cables & Systems LLC**

Contributors

- **Market Requirements and Potential**
 - **Michael Bennett, LBNL - Energy Efficiency**
 - **Robert Winter, Dell, Inc. - Need for IEEE standard**
 - **Dan Dove - smaller form factor MDI (smaller than SFP)**

- **Technical Feasibility**
 - **Chris DiMinico, MC Communications**
 - **Brian Misek, Avago Technologies**
 - **Amir Mezer, Intel**

Basic concept for CR1/CR4/CR10

- Utilize 40GBASE-CR4 (Clause 85) to specify 10GBASE-CR1

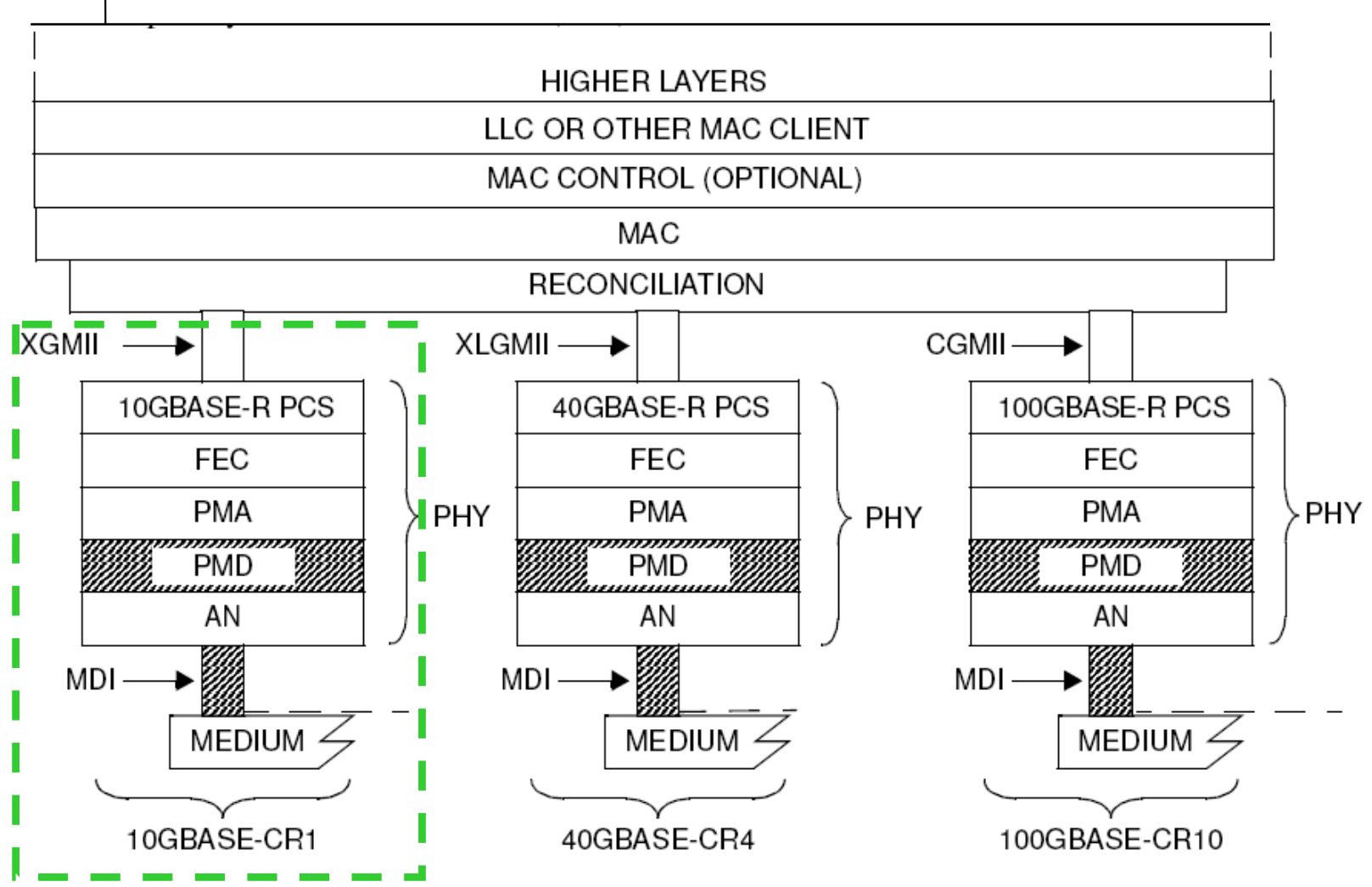

- CR1/CR4/CR10 - common electricals
- CR1/CR4/CR10 - common channel characteristics

SFF-8431

- **Considerations for use of SFF-8431 Specifications for Enhanced Small Form Factor Pluggable Module SFP+**
 - **SFI - High Speed Electrical Specifications**
 - **SFP+ Direct Attach Copper “10GSFP+Cu”**

Market Potential

Energy Efficiency and 10GBASE-CR

- **Target market is the data center**
 - **Data centers are still constrained by power, cooling, and energy costs**
 - **Energy density of devices going in the data center is increasing**
 - **Leads to wasted space**
- **802.3az will alleviate some of the energy crunch in the data center by taking advantage of periods of low utilization using Low Power Idle to reduce energy use**
- **10GBASE-CR concept is based on 10GBASE-R**
- **Low Power Idle is specified for Clause 49 (10GBASE-R PCS) so you get LPI “for free”**
 - **Additional energy can be saved beyond the PHY**
- **EPA is preparing to add 802.3az as a requirement for future Energy Star specifications for servers.**
- **Regardless of the approach, energy efficiency must be considered in future projects**

Source: Michael Bennett, Lawrence Berkeley National Laboratory

Market need for IEEE standard

- Twin-axial copper cabling between SFP+ connectors are often marketed as variants of 10GBASE-XX (e.g., 10GBASE-CU, 10GBASE-CR1, 10GBASE-CX1, etc...)
- These names are misleading as they give the appearance of being IEEE phy types.
- In fact, there is no one reference document that fully defines these interconnects which are currently in wide spread use.
- The opportunity exists for non-interoperable cable and interface assemblies to be developed to the possible harm of the vendor and user community.
- The market need is obvious, it is therefore appropriate and necessary for the IEEE to correctly and completely specify this interconnect as soon as possible.
- I support the basic concept of considering the use of 40GBASE-CR4 (Clause 85) to specify 10GBASE-CR1.

Source: Robert Winter, Dell Inc.

Market Need for Smaller, Simpler 10G Copper Solution

Market Need

- Higher Density
 - Shorter (Y), thinner (X), shallower (Z) than SFF-8431 desired
 - Unique form factor to eliminate interoperability challenges with SFF-8431
 - Single MDI definition (copper only, not pluggable optics)
- Lower Power
 - Equalization for linear channel @ 10.3125Gb
 - No external PHY chips required
 - EEE capability
- Simplified Signaling
 - No need to support EDC
- Low Cost
 - Higher Density, Lower Power, Simplified Signaling will drive cost/port down
- Compatibility
 - Create a unique form factor that does not create confusion for customers in the market (SFF-8431 linear, SFF-8431 limited, SFF-8461)

Implementation Advantage in Real Products

SFP+ Switch

- Depth of SFP+ Receptacles impacts product depth
- Width of SFP+ Receptacles impacts # of ports
- Need for EDC impacts power, depth, cost

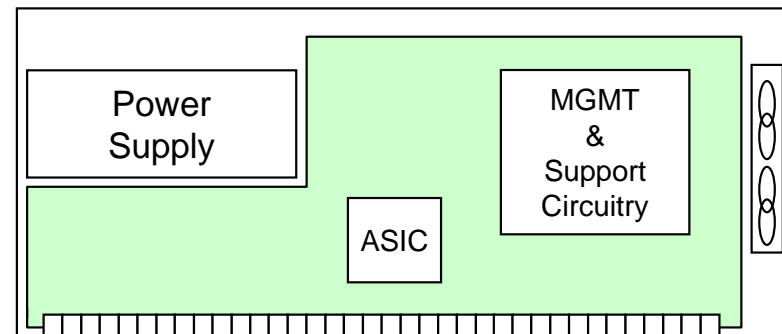
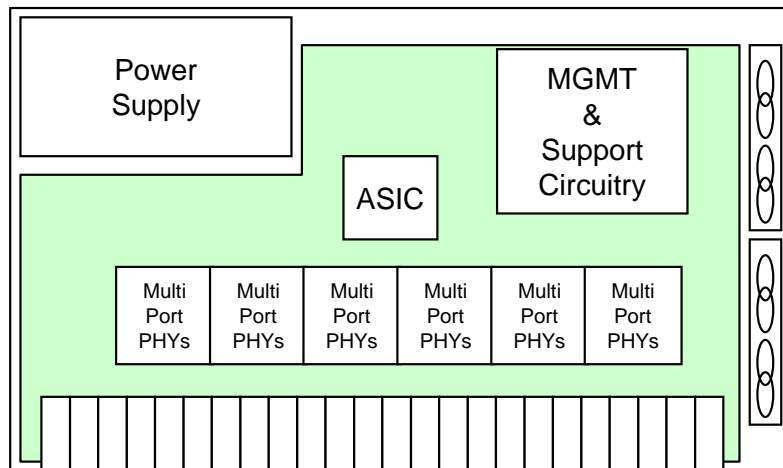

Comparison of Proposed CR1 to other 10G PHY types

10Gigabit Physical Layer Options

	Fiber	CX4	BASE-T	SFP+ Cu	CR1
Cost	High	Low	Medium	Medium	Low
Size	Medium	Medium	Medium	Medium	Low
Power	Medium	Low	High	Medium	Low
Thermal Management	High	Low	High	Low	Low
Distance	High	Low*	Medium	Low*	Low*
Multi-Rate Support	No	No	Yes	Yes	Yes
EEE Support	No	No	Yes	No	Yes

* For Stacking/Aggregation, short links acceptable

Topology Use Cases and Resulting Reach Needs

Market Applications

- **Top of Rack Data Center Switches**
 - High Port Density & Low Cost
 - 3-5 meter reach for most connections
 - EEE would enhance the Data Center opportunity
 - Time To Market critical for success
- **Top of Rack Edge Aggregation**
 - High Port Density & Low Cost
 - 3-5 meter reach for most connections
 - Time To Market critical for success
- **Stacking/Aggregation Links**
 - Port Density not as important
 - Low Cost more important
 - 3-5 meter reach for most connections

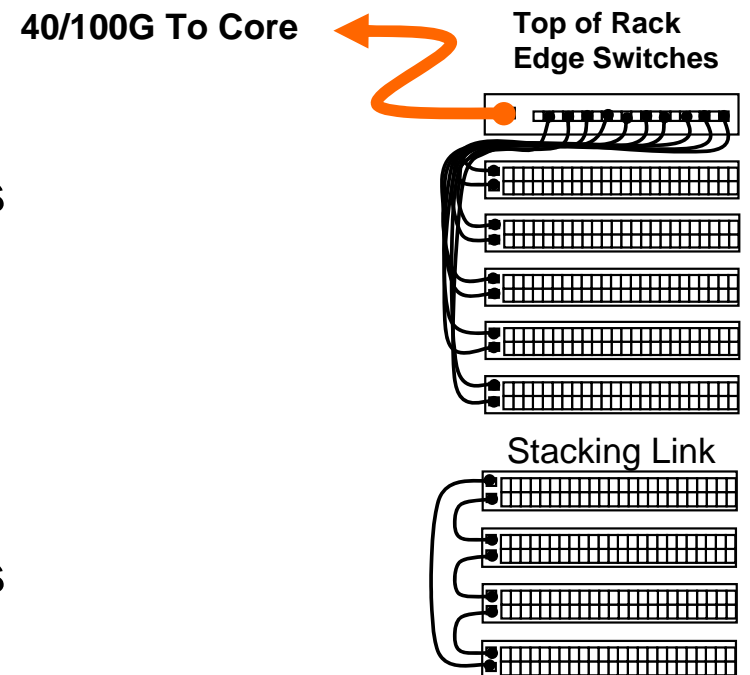
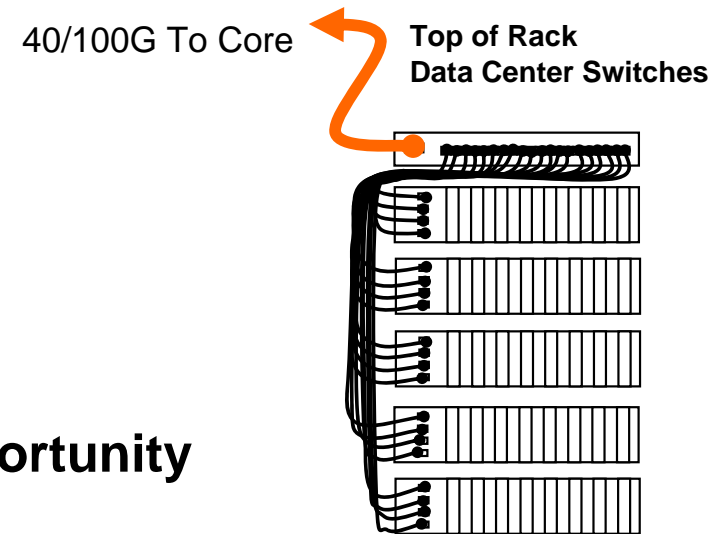

Technical Feasibility

10GBASE-KR cable assembly demonstration - Intel

- **10GBASE-KR based device tested over 10 m passive copper assembly under the following setup and conditions**
 - 10 meter Leoni 26 AWG passive twinaxial cable with 2 x SFP+ connectors and 1 x 2" and 1 x 4" FR-4 traces on test boards (6" total); ~5 dB worse @ 5 GHz than QSFP 10 meter cable assembly
 - Single NEXT aggressor
 - Adaptive TXFFE with the 10GBASE-KR protocol
 - 5-tap DFE at the receiver
- **Test results**
 - **BER=0 with PRBS31 was measured for 1500 seconds**
- **Summary**
 - Feasibility demonstrated at 10 Gb/s, very promising results with single NEXT aggressor
 - Margin should be sufficient for QSFP Xtalk environment

Source: Amir Mezer, Intel

Reference document: diminico_02_0708.pdf "802.3ba copper cable assembly baseline proposal"

CR1 and CR4 channel comparisons

- For CR1, insertion loss to crosstalk ratio determined from single disturber near-end crosstalk and insertion loss
- For CR4, insertion loss to crosstalk ratio determined from multi-disturber NEXT, multi-disturber FEXT and insertion loss.

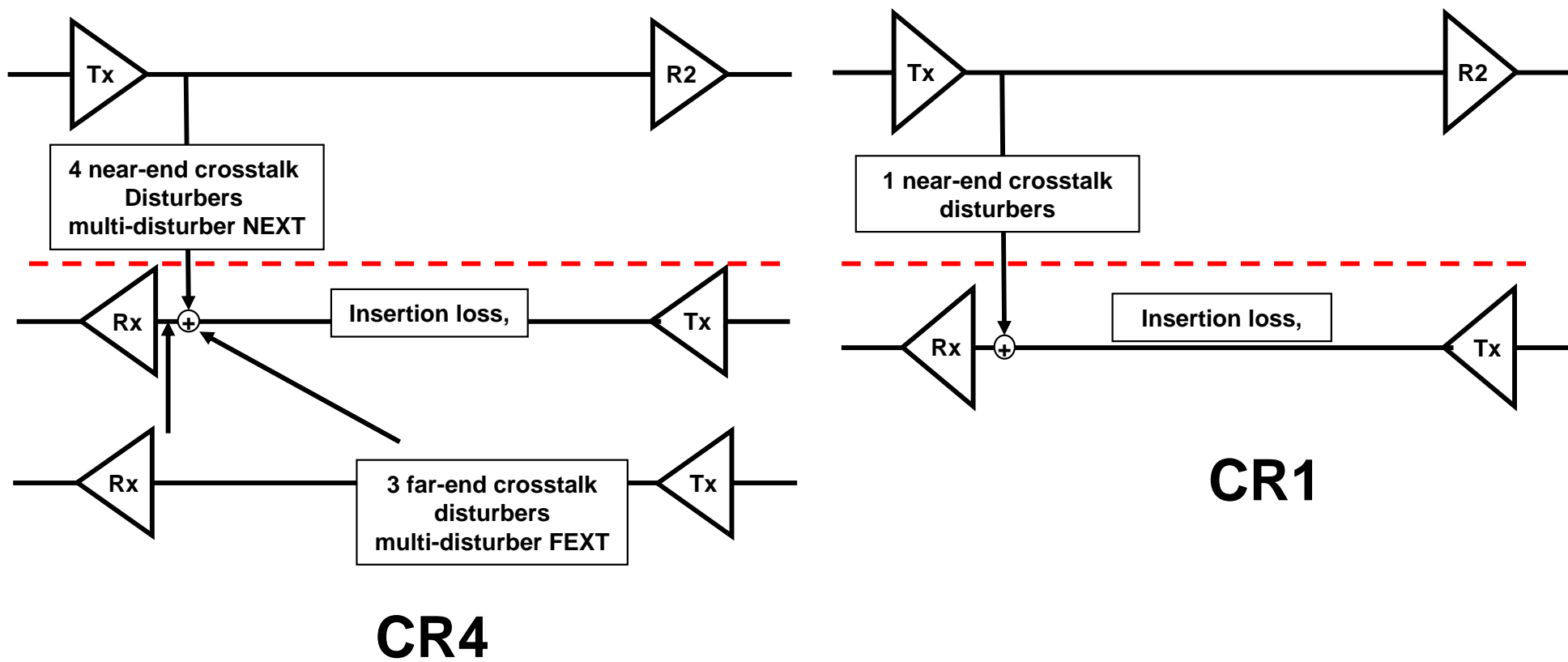

QSFP+ and SFP+ crosstalk

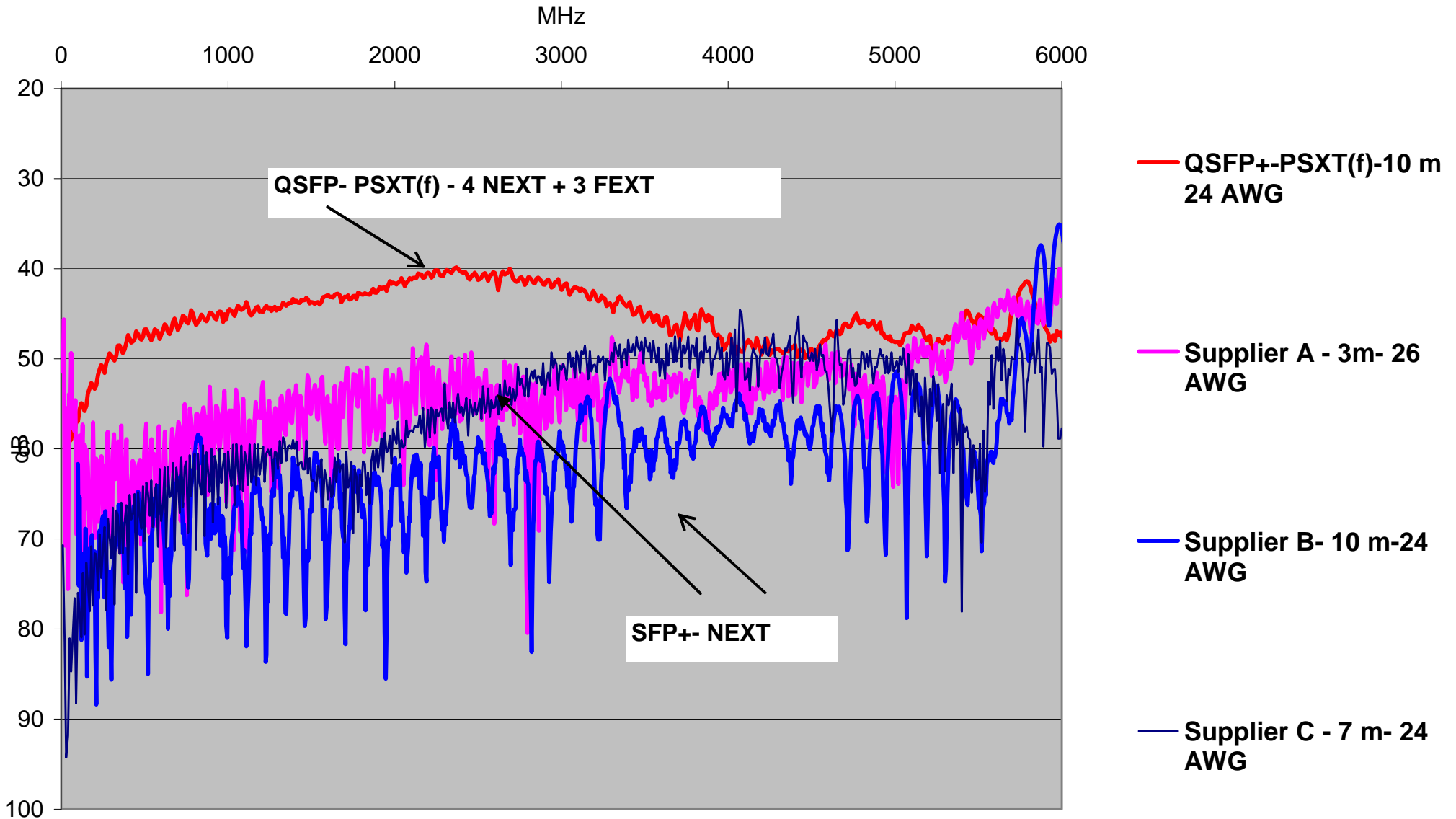

Summary

- **This Call for Interest (CFI) proposes to specify 10GBASE-CR1, a low-cost physical layer copper option for 10 Gigabit Ethernet.**
- **Consider industry available specifications**
 - **40GBASE-CR4/100GBASE-CR10 (Clause 85) electricals and channel to specify 10GBASE-CR1**
 - **SFF-8431**
- **Consider smaller form factor MDI (smaller than SFP)**
- **Support IEEE P802.3az, Energy Efficient Ethernet**
- **Compatibility with SFI hosts**
 - **Supportable copper reach (CR1 host ← → SFI host)**

Straw Polls

Call-For-Interest

- **Should a Study Group be formed for “10GBASE-CR1”?**

Y: N: A:

Participation

- **I would participate in the “10GBASE-CR1” Study Group in IEEE 802.3.**

Tally:

- **My company would support participation in the “10GBASE-CR1” Study Group in IEEE 802.3.**

Tally:

Future Work

- **Ask 802.3 to form CR1 Study Group on Thursday**
- **If approved**
 - **802 EC informed of CR1 Study Group on Friday**
 - **First 10GBASE-CR1 meeting, week of TBD**