

IEEE STANDARDS AND RECOMMENDED PRACTICES FOR CEM COMPUTER MODELING AND SIMULATION

Andrew L. Drozd

IEEE Project 1597 Working Group Chair

Sponsored by

IEEE Electromagnetic Compatibility Society

Standards Development Committee

2002 IEEE International Symposium on EMC Standards Workshop

Minneapolis, MN



Monday, 19 August 2002



TOPICS

- Background/Technical Issues
- Project Description
- Relevant Research
- Validation Issues
- Working Group Game Plan
- Survey of CEM Codes and Techniques
- Ensemble Problem Drivers
- Common Modeling Environment
- Committee/Project Status
- Work in Progress
- Conclusion

ABSTRACT

- The need for appropriate standards and guidelines for CEM computer modeling and simulation has been a topic of much discussion within the EM community in recent years.
- This encompasses a broad range of applications such as the analysis of PC board radiated and conducted emissions/immunity, assessing system-level EMC, predicting the RCS of complex structures and ATR imaging.
- Concerns exist regarding the lack of well-defined methodologies to achieve code-to-code or even simulation-to-measurement validations within a consistent level of accuracy.
- This has been prompted by the development and use of new CEM computer codes mainly over the past 20 years.
- This topic describes a project that is underway to guide the validation of CEM application models.
- The proposed standard is intended to address these concerns and provide a method for validating CEM codes and models.

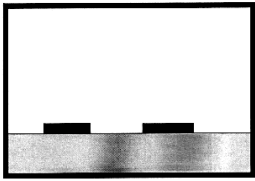

Structure Geometry

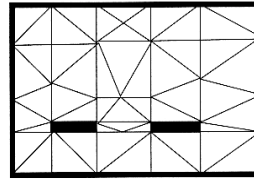

Finite-Element Mode

Figure 1: Finite-Element Modeling Example

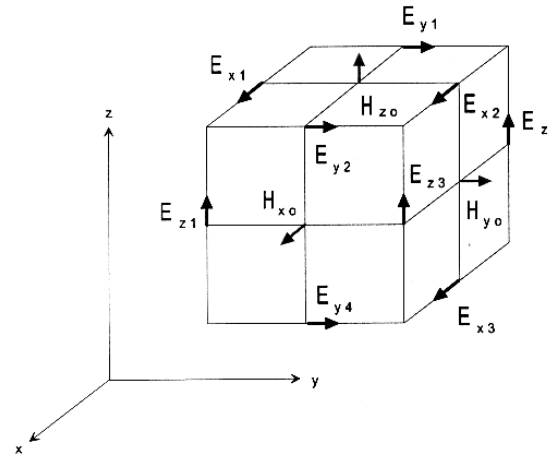

Figure 2: Basic Element of the FDTD Space Lattice

$$\nabla \times \mathbf{E} = -\mu \frac{\partial \mathbf{H}}{\partial t}$$

$$\nabla \times \mathbf{H} = \sigma \mathbf{E} + \epsilon \frac{\partial \mathbf{E}}{\partial t}$$

$$F = \int_v \frac{\mu |\mathbf{H}|^2}{2} + \frac{\epsilon |\mathbf{E}|^2}{2} - \frac{\mathbf{J} \cdot \mathbf{E}}{2j\omega} dv$$

$$\begin{bmatrix} J_1 \\ J_2 \\ \vdots \\ J_n \end{bmatrix} = \begin{bmatrix} y_{11} & y_{12} & \cdots \\ y_{21} & y_{22} & \cdots \\ \vdots & \vdots & \ddots \\ \vdots & \vdots & y_{nm} \end{bmatrix} \begin{bmatrix} E_1 \\ E_2 \\ \vdots \\ E_n \end{bmatrix}$$

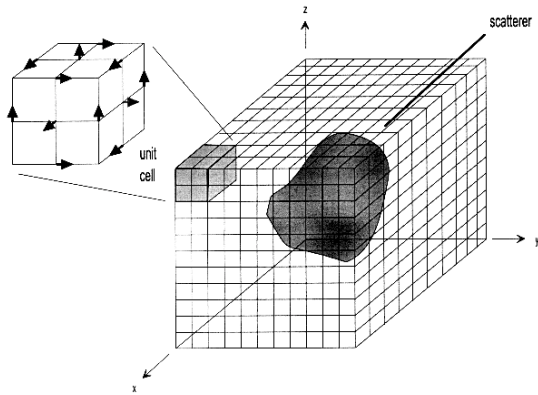

Figure 3: Scatterer in an FDTD Space Lattice

$$\nabla \times \mathbf{E} = -j\omega\mu\mathbf{H}$$

$$\nabla \times \mathbf{H} = (\sigma + j\omega\epsilon)\mathbf{E}$$

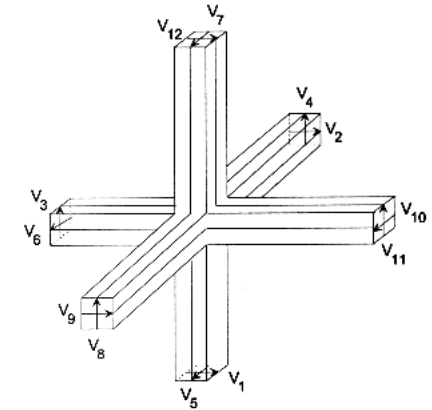
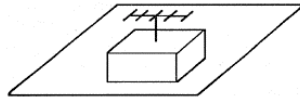
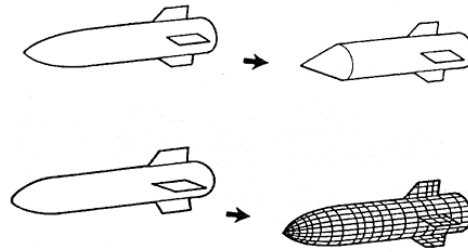

Figure 4: The Symmetrical Condensed Node



IEEE



WHICH IS CORRECT?

- Although CEM codes have their basis in Maxwell's equations of one form or another, their applicability and associated accuracies depend on:
 - the “applied” physics
 - numerical solver approach (full or partial wave, non-matrix, etc.)
 - mathematical basis functions (current expansion functions)
 - canonical modeling primitives (facets, wires, patches, canonical surfaces,...)
 - inherent modeling limitations and built-in approximations
 - desired “observables” (current or scattered fields)
 - other factors such as analysis frequency and time or mesh discretization further conspire to affect accuracy, solution convergence, and overall validity of computer models
- Concerns immediately arise when the results of predictions using one type of CEM code do not consistently agree with the results of other codes or against measurement benchmarks, begging the question, *“which is correct?”*

NEW TERRITORIES

- The idea of a CEM standard is not a new one - the need for such was realized over 30 years ago and is influenced by several factors:
 - the growing complexity and sophistication of military and commercial systems designs.
 - the need to assure a balanced, cost-effective E³ program in which computer analysis effectively complements measurements.
 - Requirements for developing consistent models and benchmarks to support life cycle EM code and measurement validations of real systems.
- Important technological advancements in computer hardware and use of structured code have accelerated the arrival of CEM technologies and applications, as we know them today.
- The fast track CEM M&S trend continues today and will grow as we further enter the age of super high performance computing.



QUESTIONS & PERSPECTIVES

- We need to eliminate (or at least significantly reduce) potential uncertainty in the modeling and simulation process.
- The EM community clearly needs a benchmark standard methodology that can assure consistency for M&S validations.
- What are the various methods that engineers use to solve CEM problems?
- What are some of the unique features of CEM methods and codes?
- The root of the problem - what seems appropriate to one expert may be inconsistent to another, yet both may (claim to) be “correct” based on their preferred tools and applied techniques.
- Although analysts may argue in favor of a given modeling approach, simulation technique or use of a particular CEM code, a consistent methodology for comparing results among codes or against empirically-based methods in a truly valid, objective way is oftentimes lacking.
- Obviously, the types of physics and solution method used for a given problem and the desired observables are central to the issue.
- Goal: determine how generalized computer models are represented or generated, and how they can be effectively converted into CEM models.
- Represent models using a common language or via a universal set of descriptors, and then specify methods to assure model and code validation based on these data?

PROJECT 1597.1

IEEE STANDARD FOR VALIDATION OF CEM COMPUTER MODELING AND SIMULATION

- Scope

- A 4-year project to develop a standard for the validation of CEM computer M&S codes in differing applications. The standard will provide a basis for analytical and empirical validation of CEM codes and configurations. Several key areas will be addressed, including:
 - Validation by use of simple, canonical models – This refers to the specification of a common set of canonical modeling elements or building blocks as a function of ensemble parameters (frequency, desired accuracy or fidelity, physics and numerical solution method, etc.).
 - Validation by simulation versus measurement - Model- versus measurement-driven uncertainty estimation).

- Purpose

- Guide the validation of CEM application models. The standard is intended to address concerns over the lack of well-defined methodologies to achieve code-to-code or simulation-to-measurement validations within a consistent level of accuracy, and provide a method for validating CEM codes and models.



PROJECT 1597.2

IEEE RECOMMENDED PRACTICE FOR CEM COMPUTER M&S APPLICATIONS

- Scope
 - A 4-year companion project to develop a recommended practice for use in CEM computer M&S applications to guide the EMC design of PC boards to large, complex systems. Areas to be addressed include:
 - General guidelines for creating CEM models.
 - Development of modeling methodologies for small-to-large scale “canonical” systems, platforms or composite models.
 - Methodologies for developing and applying collaborative, multi-disciplinary engineering modeling schemes.
 - Computation of uncertainty for modeling applications.
- This recommended practice will aid modelers and analysts in the selection and application of appropriate M&S methodologies, physics, and solution techniques to achieve accurate results and to complement measurements and design tasks for a wide range of problems.



IEEE



RELEVANT RESEARCH

- This work will build upon prior analytical studies and research conducted by academic, government, commercial and professional institutions and consortia:
 - Applied Computational Electromagnetics Society (ACES)
 - IEEE EMC Society's TC-9 Committee on CEM
 - IEEE's AP, MTT and Magnetics Societies
 - EMCC and the DoD's CHSSI/HPC Modernization Program
 - Other international groups concerned with advancing/applying CEM.
- These include studies on the modeling and simulation of multi-disciplinary engineering problems pertaining to:
 - fluid dynamics
 - laminar flow
 - structural and thermal engineering applications.
- Another key area of study is the development and use of analytical and measurement benchmarks.



VALIDATION ISSUES

- Reconciling differences among CEM codes as a function of their underlying physics, mathematical basis functions, numerical solution methods, associated precision, and the building blocks (primitives).
- Gauging convergence and “accuracy” against known/measured data.
- Results of predictions using one type of CEM code do not favorably or consistently agree with the results of other codes of comparable type or against measurement benchmarks
 - observing clear differences among analytically-based results over certain frequency regions and for certain simulation states
 - deviations between analytical and empirical methods.
- While differences are not unexpected, the degree of disparity in certain cases cannot be readily explained nor easily discounted.
- Again, a consistent methodology for comparing results among codes or against empirically-based methods in a valid, objective way is often lacking.
- It is often difficult if not impractical to compare the results of certain codes even though they are based on Maxwell’s equations.

WORKING GROUP GAME PLAN

- Develop an outline of relevant topics to be covered by the standard and recommended practice.
- Adapting relevant topics from other computational engineering standards and specifications.
- Researching the breadth and depth of state-of-the-art physics formalisms and numerical solution techniques.
- Investigating the requirements for a common data modeling framework concept.
- Addressing schemes for controllable error and statistical algorithms for characterizing known electromagnetic trends and bounds.
- Investigating methods for extending the CEM model validation concept to encompass collaborative and concurrent engineering domains and applications.



SURVEY OF NUMERICAL ELECTROMAGNETIC MODELING TECHNIQUES



WEALTH OF CEM METHODS

- Boundary Element (Integral) Method (BEM)
- Finite Element Modeling/Analysis (FEM/A)
- Method of Moments (MoM)
- Shooting Bouncing Rays (SBR)
- Physical Optics (PO)
- Physical Theory of Diffraction (PTD)
- Geometrical Optics (GO)
- Geometrical/Uniform Theory of Diffraction (GTD/UTD)
- Transmission Line Method (TLM)
- Hybrid Lumped Circuit & Quasi-Transmission Line Method
- Finite Difference Time Domain (FDTD)
- Finite Volume Time Domain (FVTD)
- Finite Difference Frequency Domain (FDFD)
- Conjugate Gradient Method (CGM)
- Generalized Multi-pole Technique (GMT - Moment Method)
- Multiple Multi-Pole (MMP)
- Fast Multi-Pole Method (FMM)
- Partial Element Equivalent Circuit Model (PEEC)
- Perfectly Matched Layers using a Partial Differential Equation Solver Method (PML/PDE)
- Adaptive Integral Method (AIM)
- Bi-Conjugate Gradient Method w/Fast Fourier Transform (BCG-FFT)
- Thin-Wire Time Domain Method (TWTDM)
- Time Domain Moment Method (TDMM)
- Vector Parabolic Equation Technique (VPE)
- Pseudo-Spectral Time Domain Method (PSTD)
- Multi-Resolution Techniques (MRT)
- Finite Integration Technique (FIT)
- Recursive Green's Function Method (RGFM)
- Analytical Discrete Method(s)
- Hybrid Techniques (MoM/UTD,...)

ELECTROMAGNETICS CODES

- NEC-BSC
- NEC-MOM
- GEMACS
- SWITCH
- Apatch
- Xpatch
- Carlos-3D
- FISC
- SCALE-Me
- EIGER
- MiniNEC

•
•
•



SOFTWARE/APPLICABILITY	COMPANY
MagNet - handles electrical, magnetic, and eddy current analysis	Infolytica
Maxwell 3D Engineering Software (including SI Eminence) - handles electrical, magnetic, eddy current, and microwave analyses with links to Spice CAD modeling capabilities	Ansoft Corporation
MSC/Magnetic, MSC/Magnum, and MSC/Maggie - handle electric and magnetic field analyses	MacNeal-Schwendler Corporation
Petfem - handles electric and magnetic field analyses	Princeton Electro-Technology, Inc.
WEMAP - handles electric, magnetic, thermal, and eddy current analyses	Westinghouse Electric Corporation
ANSYS - handles structural and mechanical design, and has magnetic field analysis capability	Swanson Analysis Systems, Inc.
IDEAS - handles FEM/A-based thermal, structural, electric and magnetic analyses	Structural Dynamics Research Corporation
Magnus - handles magnetic analysis	Magnus Software
TSAR - handles Finite Difference Time Domain (FDTD) electromagnetics analysis	Lawrence Livermore National Laboratory
XFDTD - handles Finite Difference Time Domain (FDTD) electric field analysis	REMCOM, Inc.
FLUX - handles electric and magnetic analyses	Magsoft Corporation
MARC/MENTAT - handles FEM/A-based electrostatic and magnetostatic problems with infinite boundaries	MARC Analysis Research Corporation
PE2D, Carmen, and Tosca - handle electric, magnetic, and eddy current analyses	Vector Fields, Inc.
Stripes - handles computer-aided engineering (CAE) and electromagnetics analysis using the 3-D Time-Domain Transmission Line Modeling (TLM) technique	KCC, Ltd.
EMFIELDS-3D, EMFIELDS-2D, ENEC, and EMIT - handle 2-D and 3-D Finite Difference Time Domain (FDTD) and Moment Method/wire frame modeling and analyses	Seth Corporation
Motive, XTK, Quiet, PDQ, TLC - collectively handle the electromagnetics modeling and analyses of PC board layouts and design using boundary element, time-domain finite element, and transmission line techniques	Quad Design
EMA3DF, EMA3D, EMA3DCYL, EMAEXT, and EMAFDM in addition to others - collectively handle electromagnetics analyses based on Finite Difference Time Domain (FDTD) methods (applicable to PC boards and devices, airframe structures and antenna radiators)	Electromagnetic Applications, Inc.
MAFIA - handles electric and magnetic analyses based on Finite-Integration-Algorithm (FIA). MAFIA unites several modules suitable for statics, low and high frequencies or charged particles. CST MICROWAVE STUDIO offers an alternative to MAFIA in the range of high-frequency applications.	Computer Simulation Technology, Germany
EMIT - handles EMI and radiation analyses for PC boards to antenna structures based on a general, full-wave, 3-D electromagnetics solver technique	Altium, an IBM Company
High-Performance Engineering Suite including EMC Advisor and CAD Toolkit - handle PC board electromagnetic modeling and analysis based on transmission line and time-domain modeling methods	Recal-Redac
em TM - synthesizes Spice models and handles electromagnetics analyses for lumped models of complex circuits used in PC board layouts	Sonnet Software, Inc.



CEM MODELING ISSUES (1)

- Potential sources of modeling error and associated factors
 - Limitations in the physics
 - Edge and surface traveling waves
 - Knife edge vs. wedge, tip and point diffraction
 - Phase error (loss) over large distances or dimensions at high frequencies
 - High-frequency asymptotic ray tracing approximations (ansatz based)
 - Limited current expansion functions
 - Inability to handle material discontinuities at interfaces (multilayer, anisotropic or inhomogeneous materials, FSS)
 - Shadow boundaries, creeping wave and dispersion loss effects
 - Singularity or caustic conditions where levels rapidly collapse or dramatically increase (ill conditioned, non-convergent, unstable)
 - Radiator feed modeling, FSS and mutual coupling (multi-region)
 - Solution error
 - Banded matrices, iterative convergence, full vs. partial wave solutions



CEM MODELING ISSUES (2)

- Geometry model limitations
 - Existence of multilayer regions and material interfaces
 - Ill-defined (open, closed) boundaries, region or material discontinuities
 - Gross modeling primitives described with improper resolution, elemental length or cell area (discretization scheme and geometry basis)
 - Staircasing at edges and curved surfaces
 - Inability to model the effects of doubly-curved surfaces accurately
 - Flaws in CAD model or CEM geometry model construction procedures (incomplete definitions, voids, overlaps, intersection, union, subtraction)
 - Neglecting physically small surface features at high frequencies
- Modeling procedures
 - Ill-conditioned near field problem leading to caustics, singularities, resonances, etc.
 - Use of canonical modeling objects (high-frequency ray tracing approximation) instead of actual shapes and contours
- Computation of observables
 - Singularities, caustics, resonances, discontinuity of currents, field point mismatch at/between region interfaces for multiple regions or layers



CEM MODELING ISSUES (3)

- Some possible solutions to improve accuracy and control error
 - Use of high-fidelity geometry models
 - Use of higher-order surface modeling elements and robust current expansion functions (e.g., RWA type)
 - Application of hybrid techniques to accurately model multiple regions (enforcing continuity of current and field point matching)
 - Careful exploitation of symmetry and BOR techniques
 - Accounting for or eliminating artifact “noise”
 - Use of “adaptive” optimization algorithms that maintain accuracy
 - Efficient partitioning and decomposition of submatrices
 - Streamline solutions (order reduction, increase speed, eliminate bottlenecks)
 - Sift out and suppress “off diagonal” error sources (noise)
 - Ensemble parameter reasoning (building valid CEM models)
 - Smoothing functions to control staircasing error
 - Extended precision computing and controlling error propagation
 - Use of matrix-free fast solvers and HPCs to handle large, high-resolution problems at low and high frequencies accurately



“DRIVERS” IN SELECTING AN APPROPRIATE PHYSICS & CEM CODE

- Frequency and electrical size, and geometric complexity (closed versus open geometry)
- Type of modeling primitives used to define the EM problem
- Existence of inhomogeneous, non-isotropic media
- Type of problem to be solved (e.g., large body scattering vs. PC board crosstalk)
- Desired accuracy and “observables”

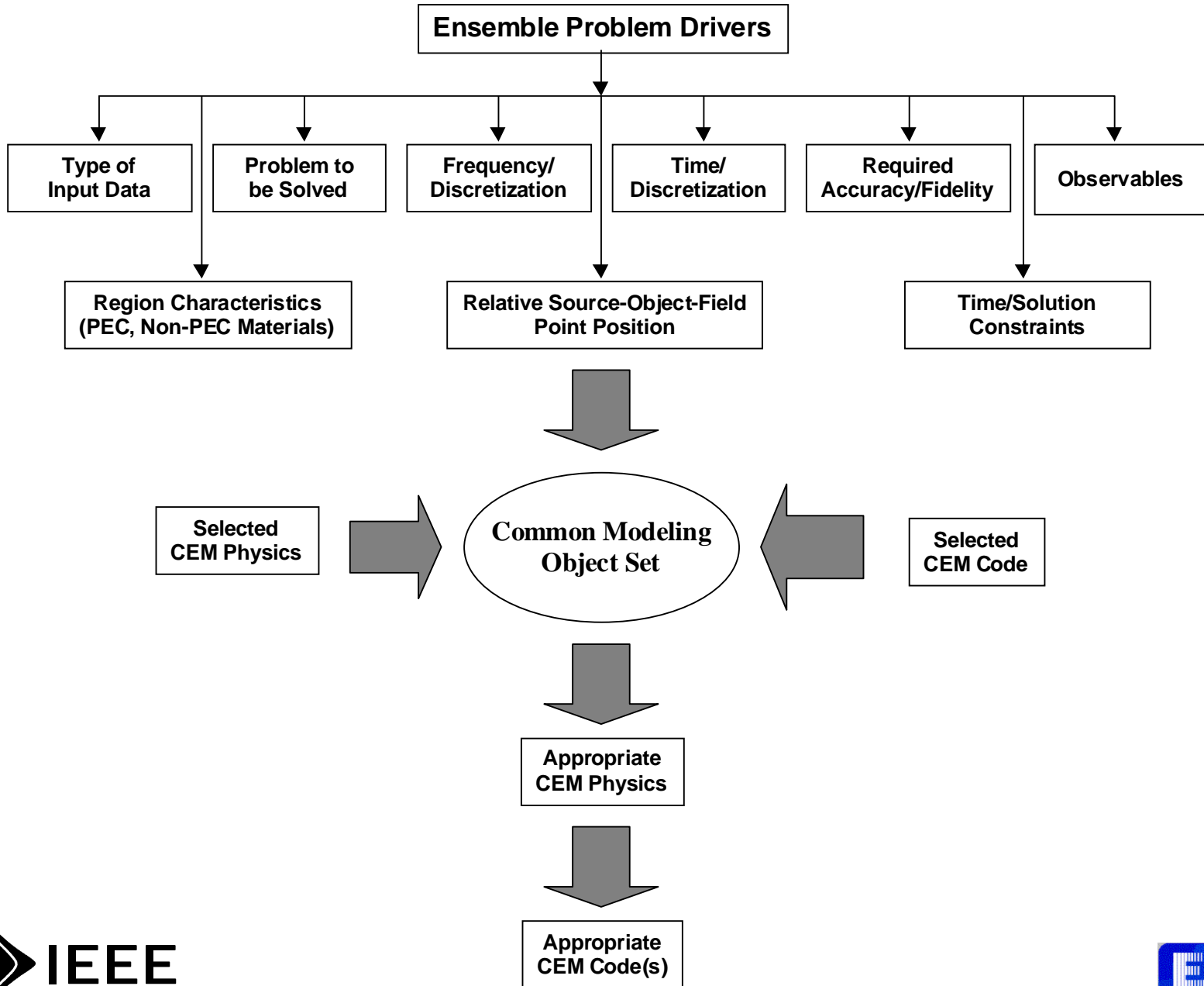

MODELING & SIMULATION SCHEME

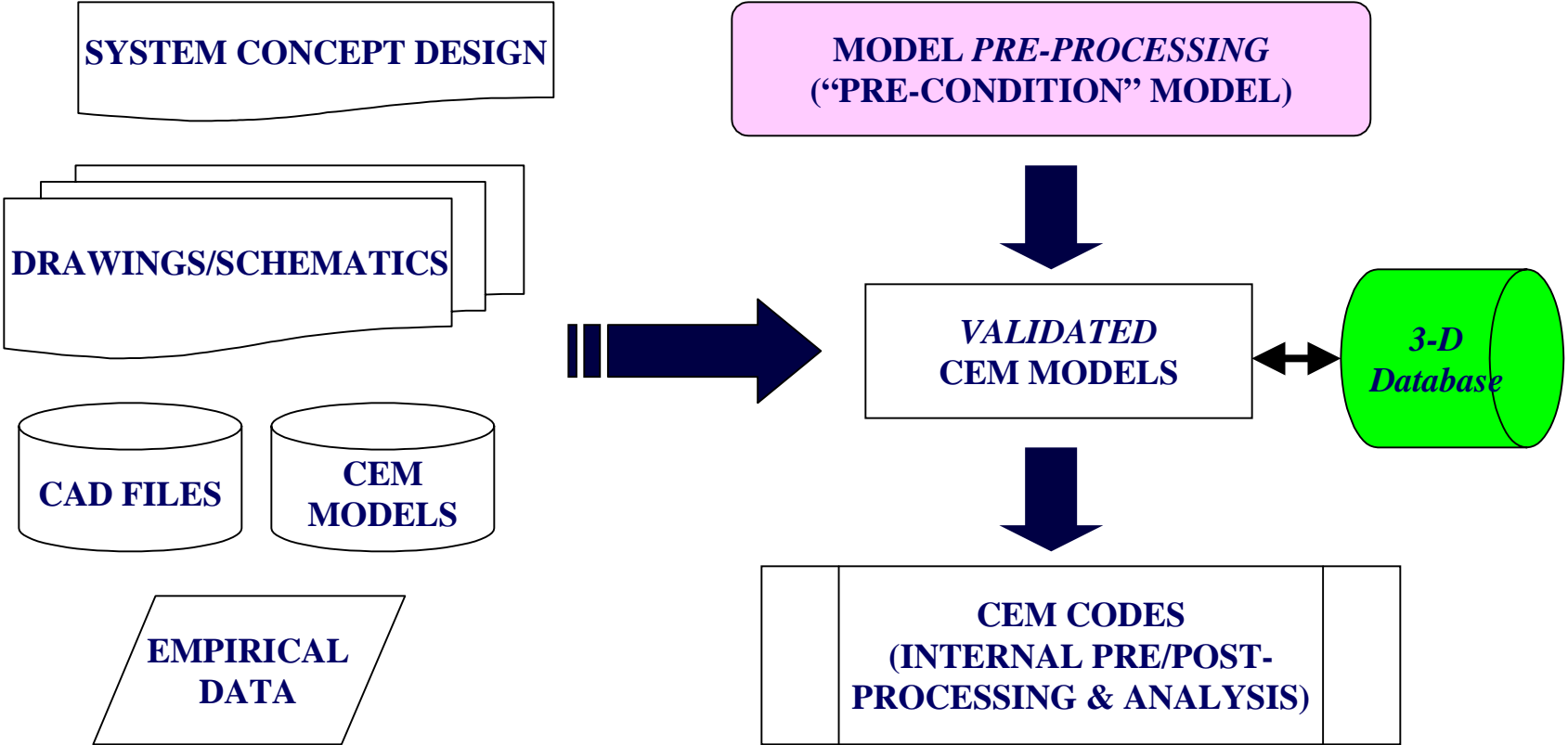

STANDARD ENVIRONMENT

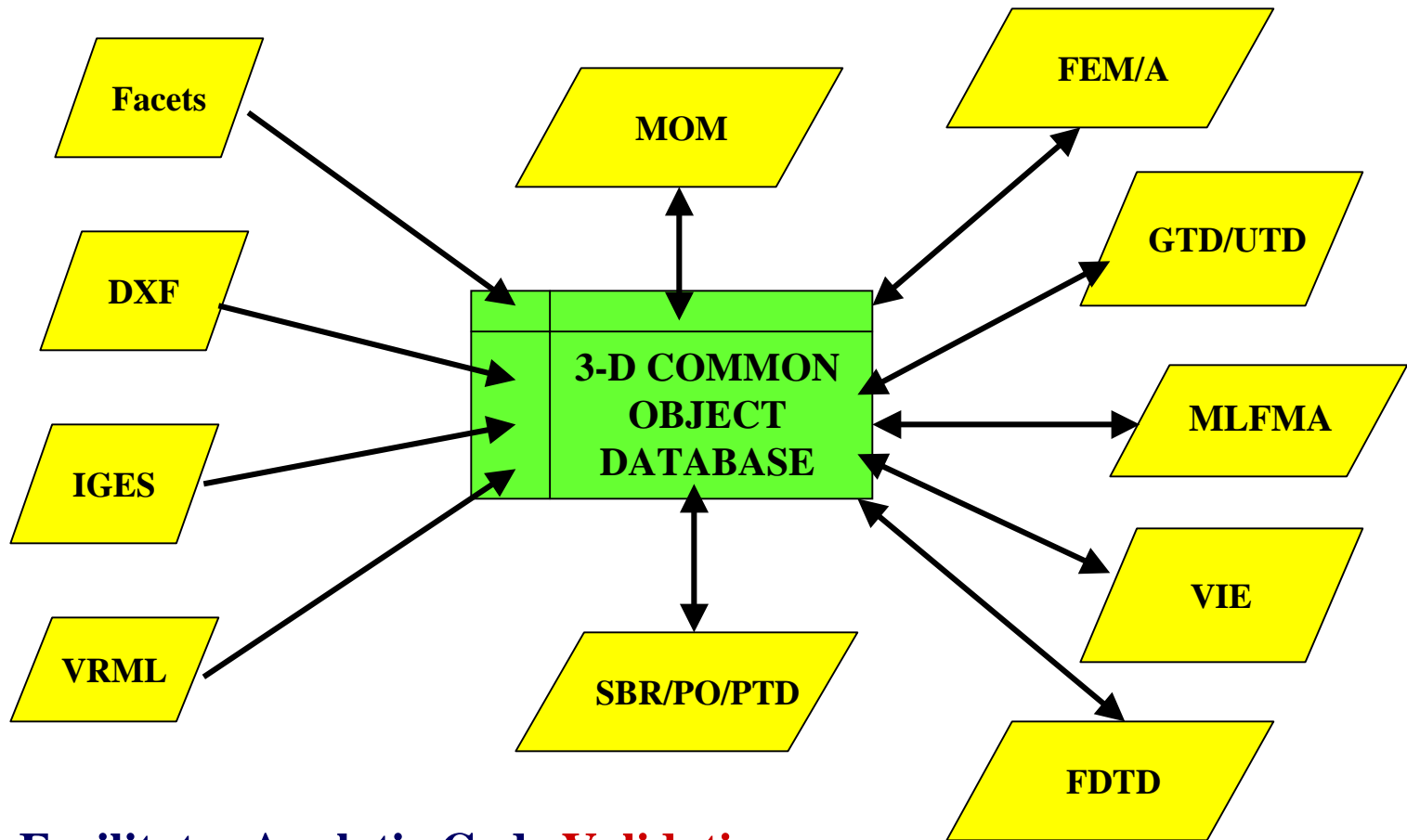

-Facilitates Analytic Code Validation

Benchmarking Efforts

Standard Definitions

COMMITTEE/PROJECT STATUS

- First Working Group meeting was held on 8/13/01 in conjunction with the 2001 IEEE International Symposium on EMC in Montreal.
- 17 attendees - government ($\approx 25\%$), industry ($\approx 50\%$), and academia ($\approx 25\%$).
- The estimated user/producer/general interest profile:
 - 100% (code users)
 - 50% (code producers/developers)
 - 100% (general and materially interested organizations).
- Meeting cycle: 2-3 times per year in conjunction with symposia, conferences, or review meetings.
- Meetings in Monterey (3/02), Albuquerque (5/02) & RTP (6/02)
- The Working Group Officers:
 - Andy Drozd of ANDRO Computational Solutions, Rome, NY (Chair)
 - Dr. Bruce Archambeault of IBM, Research Triangle Park, NC (Vice Chair)
 - Dr. Maqsood Mohd of Sverdrup Technology, Eglin AFB, FL (Secretary).



WORK IN PROGRESS

- Charter, Policies & Procedures
- Outline of draft standard/recommended practice - writing assignments
- Key technical/technology issues studied
 - Primitive Modeling Elements
 - Simple Canonical Bodies
 - Large Complex Systems/Structures
- Documentation/relevant projects
 - ACES challenging problems
 - Code validation
 - Existing benchmarks
 - Standard Interface Data Structures (CFD SIDS)
 - CFD General Notation System” (CGNS)
- Other Technical Issues
 - Measurement and error control
 - Statistical techniques

REFERENCES

- B. Archambeault and J. Drewniak, “*EMI Model Validation and Standard Challenge Problems*”, <http://aces.ee.olemiss.edu/>.
- Electromagnetic Code Consortium Web Site
<http://www.asc.hpc.mil/PET/CEA/emcc/benchmark/benchmark.html>.
- *CGNS, The CFD General Notation System Overview and Entry-Level Document*, CGNS Project Group, 15 May 1998.

CONCLUSION

- A CEM standard will provide a consistent methodology for developing valid models, performing M&S validations as well as validating codes.
- Provide a guide for the validation of CEM application models i.e., when and how to apply certain code-specific modeling techniques in view of the physics and nuances of the CEM codes to control (manipulate) error and optimize accuracy and fidelity.
- Provide a basis for representing models possibly by using a common language or via a universal set of descriptors, and then specifying methods to assure model and code validation utilizing these data.
- Assure flexibility to cover a broad range of applications.
- Fill any voids in current methods and practices to achieve code-to-code or simulation-to-measurement validations within a consistent level of accuracy, and provide a method for validating CEM codes and models.