

IEEE Std 473-1985

IEEE Recommended Practice for an Electromagnetic Site Survey (10 kHz to 10 GHz)

Sponsor

**Technical Committee 3 on Electromagnetic Environments
of the
IEEE Electromagnetic Compatibility Society**

Approved September 17, 1981
Reaffirmed September 26, 1991

IEEE Standards Board

Approved December 13, 1985
Reaffirmed May 6, 1992

American National Standards Institute

© Copyright 1985 by

**The Institute of Electrical and Electronics Engineers, Inc
345 East 47th Street, New York, NY 10017, USA**

No part of this publication may be reproduced in any form, in an electronic retrieval system or otherwise, without the prior written permission of the publisher.

IEEE Standards documents are developed within the Technical Committees of the IEEE Societies and the Standards Coordinating Committees of the IEEE Standards Board. Members of the committees serve voluntarily and without compensation. They are not necessarily members of the Institute. The standards developed within IEEE represent a consensus of the broad expertise on the subject within the Institute as well as those activities outside of IEEE which have expressed an interest in participating in the development of the standard.

Use of an IEEE Standard is wholly voluntary. The existence of an IEEE Standard does not imply that there are no other ways to produce, test, measure, purchase, market, or provide other goods and services related to the scope of the IEEE Standard. Furthermore, the viewpoint expressed at the time a standard is approved and issued is subject to change brought about through developments in the state of the art and comments received from users of the standard. Every IEEE Standard is subjected to review at least once every five years for revision or reaffirmation. When a document is more than five years old, and has not been reaffirmed, it is reasonable to conclude that its contents, although still of some value, do not wholly reflect the present state of the art. Users are cautioned to check to determine that they have the latest edition of any IEEE Standard.

Comments for revision of IEEE Standards are welcome from any interested party, regardless of membership affiliation with IEEE. Suggestions for changes in documents should be in the form of a proposed change of text, together with appropriate supporting comments.

Interpretations: Occasionally questions may arise regarding the meaning of portions of standards as they relate to specific applications. When the need for interpretations is brought to the attention of IEEE, the Institute will initiate action to prepare appropriate responses. Since IEEE Standards represent a consensus of all concerned interests, it is important to ensure that any interpretation has also received the concurrence of a balance of interests. For this reason IEEE and the members of its technical committees are not able to provide an instant response to interpretation requests except in those cases where the matter has previously received formal consideration.

Comments on standards and requests for interpretations should be addressed to:

Secretary, IEEE Standards Board
345 East 47th Street
New York, NY 10017
USA

Foreword

(This Foreword is not a part of IEEE Std 473-1985, IEEE Recommended Practice for an Electromagnetic Site Survey (10 kHz to 10 GHz).)

In the field of radio engineering the need for practitioners to perform an electromagnetic site survey is common. The specific objectives of site surveying vary widely as do the details of the sites where they are executed. Thus, while surveys also have much in common, allowance for these variances must be preserved in a standard practice. The objective of this recommended practice is to preserve necessary freedom of choice and to make due allowance for individuality in survey practice while carefully articulating those elements of radio-frequency surveying that can and should be common to all undertakings. Only by standardizing the essential survey procedures and equipments can coherent representations of the radio-frequency environment emerge and become beneficial to the radio-engineering community.

This recommended practice draws from a wealth of technical material, far too extensive to be addressed except by reference. All users are urged to make generous use of the citations which have been carefully screened for relevance.

The Committee is indebted to the many anonymous members of the IEEE and other technical societies who have unselfishly contributed to this effort.

It is the hope and request of the Committee that, as use is made of this recommended practice, its flaws will be brought to our attention so that it may be improved to better serve the engineering community.

At the time this standard was approved, the members of Technical Committee 3 on Electromagnetic Environments of the IEEE Electromagnetic Compatibility Society were as follows:

E. N. Skomal, Chair

C. B. Christianson
J. W. Engles

R. R. Ford
D. N. Heirman
W. R. Lauber

A. A. Smith, Jr
R. A. Tell

When the IEEE Standards Board approved this standard on September 17, 1981, it had the following membership:

Irvin N. Howell, Jr, Chair
Irving Kolodny, Vice Chair
Sava I. Sherr, Secretary

G. Y. R. Allen
J. J. Archambault
James H. Beall
John T. Boettger
Edward Chelotti
Edward J. Cohen
Len S. Corey

Jay Forster
Kurt Greene
Loering M. Johnson
Joseph L. Koepfinger
John E. May
Donald T. Michael*
John P. Riganati

Frank L. Rosa
Robert W. Seelbach
Jay A. Stewart
W. E. Vannah
Virginius N. Vaughan, Jr
Art Wall
Robert E. Weiler

*Member emeritus

Letter Symbols for Quantities

A antenna aperture area
AF antenna factor
AF_c antenna factor of a calibrated reference antenna

B	noise bandwidth
D_1	lower decile value of a random variable
\hat{D}	deflection of a trace
D_s	dimension of a radiating source
D_u	upper decile value of a random variable
\tilde{d}	antenna dimension (usually diameter)
$d\hat{\alpha}(N)$	confidence bound for sample size N
$d\hat{A}$	confidence bound
E	electric field strength (V/m)
E_{dB}	electric field strength, decibels (ref 1 $\mu\text{V/m}$)
F	$10 \log f$, noise figure for a receiving system
F_a	external (antenna) noise figure, $F = 10 \log f_a$
F_{am}	median value of F_a
$F_o(x)$	theoretical cumulative distribution of the random variable x
f	operating noise factor for a receiving systems
f_a	external noise factor
f_p	impulse repetition rate
f_r	receiver noise factor
Δf	scan frequency interval
Δf_{6dB}	6 dB bandwidth
Δf_{imp}	impulse bandwidth
G	antenna gain expressed in decibels
g	antenna gain
\hat{h}	physical length of a linear antenna
H	magnetic field strength in amperes per meter
k	Boltzmann's constant, $1.38 \cdot 10^{-23}$ J/K
L_u	largest dimension of an antenna
l	added receiver circuit attenuation factor
l_c	antenna circuit loss factor
l_t	transmission line loss factor
MR_c	output voltage of a calibrated reference antenna expressed in decibels relative to 1 W
MR_t	output voltage of a test antenna expressed in decibels relative to 1 W
N	sample size
N_t	number of threshold levels
P_n	noise power in decibels relative to 1 W
p_n	noise power
μP	power per megahertz in decibels relative to 1 μW
$p_o(v_i)$	probability the i th threshold voltage will be exceeded
$\Delta p_o(v_i)$	incremental probability
p_r	detected power in watts
$p(\alpha)$	probability α
R	frequency scanning rate in hertz per second
R_c	charging time constant resistance
R_d	discharging time constant resistance
r	resistance in ohms
S	noise power flux density, dB (W/m ²) Hz
$S_N(x)$	observed cumulative distribution of a sample size, N , of random variable x
S_r	slew rate of a recorder
T	measurement time interval
T_a	antenna temperature
T_e	effective noise temperature of a receiver
T_o	reference temperature, 288 K
t_m	minimum frequency scan time

V	$10 \log v$, v in volts
V_{av}	mean value of v
V_d	voltage deviation
V_i	incremental value of v_i
V_{peak}	peak voltage
v_{rms}	root mean square voltage
$v_{1,2}$	envelope voltage values
v_i	i th threshold voltage value
Δv	difference between the i th and the $(i+1)$ threshold voltage
w	power density, in watts per centimeters squared
\bar{x}	median of true population, x
x_i	i th value of the random variable x
x_m	median value of a subset of random variable x
Z_o	impedance of free space, 377Ω
α	circuit parameter: see [27]
α	statistical significance level
Γ	slope or the cumulative distribution of a random variable in the vicinity of the median value
\hat{I}	antenna efficiency
η	allowable fractional increase in system noise temperature
λ	radio signal wavelength in a vacuum
λ_m	free space wavelength of the lowest measurement frequency
$\bar{\sigma}_s$	median value of the root-variance of building attenuation
T	time

Unit Symbols

K	Kelvin
ms	milliseconds
dBw	dB (ref 1 w)
V	volts
dB(μ V/MHz)	spectral intensity expressed in decibels
kHz	kilohertz

Abbreviations

ACR	average crossing rate of the envelope voltage
APD	amplitude probability distribution. <i>See</i> $D(v)$
BFO	beat frequency oscillator
BLK	black
cw	continuous wave
cm	common mode
crt	cathode ray tube
dm	differential mode
EMC	electromagnetic compatibility
FSK	frequency shift keying
GRN	green
if	intermediate frequency
PDD	pulse duration distribution
PSD	pulse spacing distribution
rf	radio frequency
RTT	radio teletype
WHT	white
ISM	instrument, scientific, and medical
NCFSK	noncoherent frequency shift keying

CLAUSE	PAGE
1. Introduction	1
2. Definitions.....	2
3. References	3
4. Test Planning.....	6
4.1 Site Electromagnetic Environment	6
4.2 Data Sampling.....	10
4.3 Documentation of Site Characteristics.....	12
5. Site Survey Procedures	13
5.1 General	13
5.2 Exterior Location Considerations	15
5.3 Interior Location Considerations	17
5.4 Power-Density Surveys, Interior and Exterior Locations	20
5.5 Surveys of Power-Distribution Systems	21
6. Antennas.....	22
6.1 Introduction.....	22
6.2 Ground Plane and Monopole Counterpoise	23
6.3 Antenna Calibration Procedures	23
6.4 Types of Antennas	24
7. Measuring Equipment and Receivers	28
7.1 Introduction.....	28
7.2 Attenuators	28
7.3 Preselector Filters.....	29
7.4 Preamplifiers	29
7.5 Tuning Range.....	30
7.6 Bandwidth	30
7.7 Linear Dynamic Range	30
7.8 Image and Spurious Signal Rejection	30
7.9 Receiver Noise Figure.....	30
7.10 Antenna Transmission Line and Receiver Calibration	31
8. Detector Functions	32
8.1 Introduction.....	32
8.2 Detector Types	33
8.3 Detector Accuracy.....	35
8.4 Associated Output Devices	35
8.5 Comparison of Detector Functions	36
8.6 Amplitude Probability Distribution (APD), and ACR, PSD, and PDD.....	36
9. Data Handling	37
9.1 Data Recording	37

CLAUSE	PAGE
9.2 Data Processing	44
9.3 Examples of Data Usage	44
10. Exterior Test Measurement Platforms	47
10.1 Ground Based Measurements	47
10.2 Marine Measurements	48
10.3 Airborne Measurements	48
Annex A (informative) Derivation of the External Noise Figure F_a , for Several Antennas	49
Annex B Bibliography	54

IEEE Recommended Practice for an Electromagnetic Site Survey (10 kHz to 10 GHz)

1. Introduction

An electromagnetic (em) site survey is a systematic, documented investigation of the amplitudes of radio-frequency (rf) em fields found at one or more locations with respect to frequency, time, and position. Although these ambient em fields may have intrinsic interest, more commonly they will be regarded as radio noise or simply as interference. This *noise level* establishes the minimum useable signal strength for satisfactory service. Furthermore, it often dictates equipment design decisions intended to reduce any adverse effects of this interference on system performance. Survey sites of interest may be at virtually any indoor or outdoor location. Radio-frequency sampling may involve either airborne or surface platforms.

Electromagnetic nonionizing radiation studies are generally initiated for one of two reasons

- 1) To characterize the performance of an existing or planned electronic system
- 2) To examine the potential contribution to short- and long-term biological effects

Recognizing the potentially diverse uses of survey results, a systematic approach has been developed allowing accurate cross-comparison of data collected at different times and locations.

This practice addresses periodic and random radiated electric and magnetic fields and conducted interference within the frequency range of 10 kHz to 10 GHz. Several aspects of radioemission investigations are not addressed directly in this text including signal identification and discrimination, field emission from regularly occurring, low-frequency, pulses sources, and test enclosure fields. However, much information pertinent to these areas is provided here.

Throughout this recommended practice letter symbols for quantities are in accordance with ANSI/IEEE Std 280-1985 [10]¹ and letter symbols for units of measurement are in accordance with ANSI/IEEE Std 260-1978 [9]. See ANSI Y1.1-1972 (R 1984) [6] for abbrevitions.

¹The numbers in brackets correspond to those of the references in Section 3.

2. Definitions

Specialized terms and expressions used throughout this recommended practice and not found in ANSI/IEEE Std 100-1984 [7] are listed here.

average crossing rate (ACR). The average number of crossings in the positive direction of a given level v_i per unit time. (See Fig 1.)

amplitude probability distribution (APD). A distribution showing the probability (commonly a percentage of time) that an amplitude is exceeded as a function of amplitude v_1 .

decile, D_l . The ratio of the lower decile value (the value of x exceeded 90% of the time) of the random variable x to its median value, expressed in decibels.

decile, D_u . The ratio of the upper decile value (the value of x exceeded 10% of the time) of the random variable x to its median value, expressed in decibels.

envelope voltage or voltage envelope. The magnitude of the complex representation of the observed instantaneous voltage.

NOTE — Envelope voltage is always a positive quantity permitting the logarithmic operation to be performed upon the value.

impulse bandwidth. The ratio of the maximum value of the voltage at the output of a network (when properly corrected for network sinewave gain at the stated reference frequency) to the spectrum amplitude of the pulse applied at the input. In networks with a single-humped response the reference frequency is taken as that at which the gain is maximum.

pulse duration distribution (PDD). The fraction of pulse duration at level v_i that exceeds time T . (See Fig 1.)

pulse spacing distribution (PSD). The fraction of pulse spacing time, at level v_i that exceeds time T . (See Fig 1.)

receiver 1 dB gain compression point. The input signal level to an otherwise linear receiver for which the gain has been decreased 1 dB below the value measured for the minimum detectable input signal (within the linear response range).

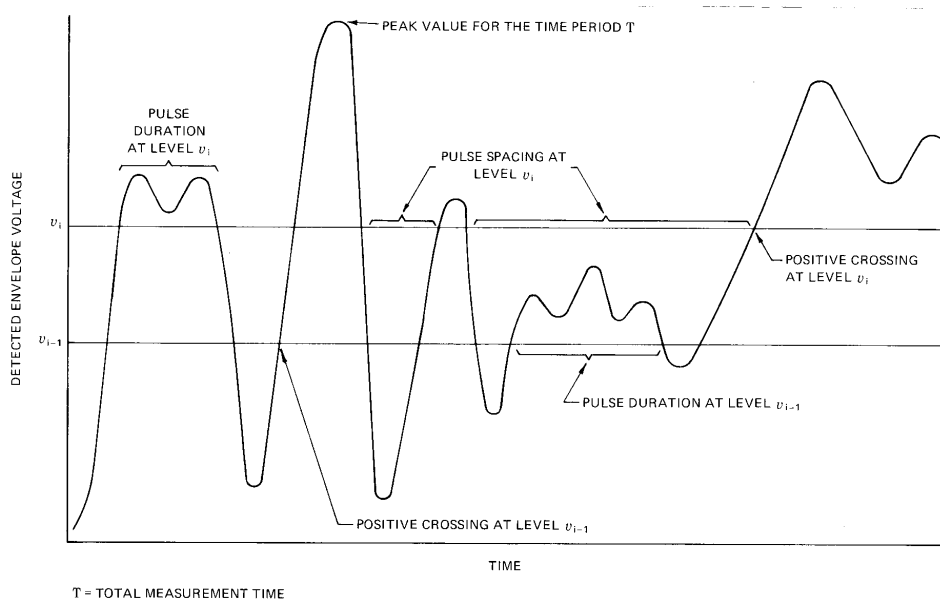

Figure 1— Typical Noise Envelope of a Man-Made Radio-Noise Process

receiver linear dynamic range. The interval between the minimum detectable signal and the 1 dB gain compression point within which the receiver gain deviates from a constant value by less than 1 dB.

voltage deviation, V_d . The ratio of the root mean squared envelope voltage to the average envelope voltage of a signal expressed in decibels.

3. References

When the American National Standards referred to in this recommended practice are superseded by a revision approved by the American National Standards Institute, Inc, the revision shall apply.

[1] ANSI C63.2-1980, American National Standard Specifications for Electromagnetic Noise and Field Strength Instrumentation, 10 kHz to 1 GHz.²

[2] ANSI C63.4-1980, American National Standard Methods of Measurement of Radio-Noise Emissions from Low-Voltage Electrical and Electronic Equipment in the Range of 10 kHz to 1 GHz.

[3] ANSI C95.1-1980, American National Standard Safety Levels with Respect to Human Exposure to Radio Frequency Electromagnetic Fields, 300 kHz to 100 GHz.

[4] ANSI C95.3-1973 (R 1979), American National Standard Techniques and Instrumentation for the Measurement of Potentially Hazardous Electromagnetic Radiation at Microwave Frequencies.

[5] ANSI C95.5-1980, American National Standard Recommended Practice for the Measurement of Hazardous Electromagnetic Fields—RF and Microwave.

[6] ANSI Y1.1-1972 (R 1984), Abbreviations for Use on Drawings and in Text.

[7] ANSI/IEEE Std 100-1984, IEEE Standard Dictionary of Electrical and Electronics Terms.³

[8] ANSI/IEEE Std 149-1979, IEEE Standard Test Procedures for Antennas.

[9] ANSI/IEEE Std 260-1978, IEEE Standard Letter Symbols for Units of Measurement (81 Units, Customary Inch-Pound Units, and Certain Other Units).

[10] ANSI/IEEE Std 280-1985, IEEE Standard Letter Symbols for Quantities Used in Electrical Science and Electrical Engineering.

[11] ANSI/IEEE Std 474-1973 (R 1982), IEEE Standard Specifications and Test Methods for Fixed and Variable Attenuators, DC to 40 GHz.

[12] ANSI/IEEE Std 488-1978, IEEE Standard Digital Interface for Programmable Instrumentation.

[13] CBEMA-ESC5-1977, Computer and Business Manufacturers Association Limits and Methods of Measurement of Electromagnetic Emanations from Electronic Data Processing and Office Equipment, May 20, 1977.⁴

[14] CCIR R 322-1963, Distribution and Characteristics of Atmospheric Radio Noise.⁵

[15] IEEE Std 291-1969 (R 1981), IEEE Standards Report on Measuring Field Strength in Radio Wave Propagation.

[16] IEEE Std 302-1969 (R 1981), IEEE Standard Methods for Measuring Electromagnetic Field Strength for Frequencies Below 1000 MHz in Radio Wave Propagation.

²ANSI publications are available from the Sales Department, American National Standard Institute, 1430 Broadway, New York, NY 10018.

³IEEE publications are available from the Institute of Electrical and Electronics Engineers, Service Center, 445 Hoes Lane, Piscataway, NJ 08854.

⁴CBEMA publications are available from the Computer and Business Machine Manufacturers Association, 311 First St, NW, Suite 500, Washington, DC 20001.

⁵CCIR publications are available in the US from National Technical Information Service, Department of Commerce, 5285 Port Royal Road, Springfield, VA 22161.

- [17] MIL-STD-462 1967, Measurement of Electromagnetic Interference Characteristics.⁶
- [18] NCDRH 21 CFR, Part 1030.10, Performance Standard for Microwave and Radio-Frequency Emitting Products, Apr 1983.⁷
- [19] Reference Data for Radio Engineers. New York: Howard W. Sams Company, 1975.
- [20] SAE-AIR 1509-1978, EMC Antennas and Antenna Factors: How to Use them.⁸
- [21] Health and Welfare, Ottawa, Canada, Safety Code 6, *Recommended Safety Procedures for the Installation and Use of Radio Frequency and Microwave Devices in the Frequency Range 10 MHz to 300 GHz*, Feb 1979.
- [22] ANDREWS, B. H. The Flux Densities of Twenty Radio Sources at 31.1 Mc/s. *Journal of Astrophysics*, Feb 1967, pp 423–432.
- [23] BOISCHOT, A. Les Bruits Cosmiques. *AGARD Conference Proceedings for Electromagnetic Noise, Interference and Compatibility no 159*, Nov 1975, pp 4-1 and 4–12.
- [24] BULLINGTON, K. Radio Propagation Fundamentals. *Bell Systems Technical Journal*, vol 36, no 3, May 1957, pp 593–626.
- [25] COTTONY, H. V., and JOHLER, J. R. Cosmic Radio-Noise Intensities in the VHF Band. *Proceedings of the IRE*, vol 40, no 9, Sept 1952, pp 1053–1060.
- [26] DIETZ, J. Examination of the Feasibility of Conventional Land Mobile Operations at 950 MHz, Phase I, Base-to-Mobile. *FCC Report*, R-1702, Mar 1971.
- [27] GESELOWITZ, D. B. Response of Ideal Radio Noise Meter to Continuous Sine Wave, Recurrent Impulses, and Random Noise. *IRE Transactions on Radio-Frequency Interference*, vol RFI-3, no 1, May 1961, pp 2–11.
- [28] GREENE, F. M. Influence of the Ground on the Calibration and Use of VHF Field-Intensity Meters. *Journal of Research of the National Bureau of Standards*, vol 44, no 2, Feb 1950.
- [29] HABER, F. Response of Quasi-Peak Detector to Periodic Impulses with Random Amplitudes. *IEEE Transactions on Electromagnetic Compatibility*, vol EMC-9, no 1, Mar 1967, pp 1–5.
- [30] HAGN, G. H. Calibration of 9-ft Rod Antenna for MF and HF EMC Measurements. *IEEE International Electromagnetic Compatibility Symposium Record*, vol EMC-S, June 1978, pp 160–168.
- [31] KRAUS, J. D. *Radio Astronomy*. New York: McGraw-Hill, 1966.
- [32] LARSEN, E. B. and RIES, F. X. Design and Calibration of the NBS Isotropic Electric-Field Monitor (EFM-5), 0.2 to 1000 MHz. *National Bureau of Standards Technical Note 1033*, Mar 1981.
- [33] LARSEN, E. B. and SHAFER, J. F. Surveys of Electromagnetic Field Intensities Near Representative Higher-Power FAA Transmitting Antennas. *Federal Aviation Report*, FAA-RD-77-179, Dec 1977.

⁶MIL publications are available from the Director, US Navy Publications and Printing Service, Eastern Division, 700 Robbins Avenue, Philadelphia, PA 19111.

⁷NCDRH publications are available from the Technical Information Staff (HF-X-28), National Center for Devices and Radiological Health, FDA, 5600 Fishers Lane, Rockville, MD 20857.

⁸SAE publications are available from the Society of Automotive Engineers, Inc, 400 Commonwealth Drive, Warrendale, PA 15096.

- [34] LIN, JAMES C., GUY, ARTHUR W., and JOHNSON, CURTIS C. Power Deposition in a Spherical Model of Man Exposed to 1–20 MHz Electromagnetic Fields. *IEEE Transactions on Microwave Theory and Techniques*, vol MTT-21, Dec 1973, pp 791–797.
- [35] LONGLEY, A. G. Location Variability of Transmission Loss-Land Mobile and Broadcast Systems. *Office of Telecommunications Report*, ORT-76-87, May 1976.
- [36] LONGLEY, A. G., and RICE, P. L. Prediction of Tropospheric Radio Transmission Loss Over Irregular Terrain, A Computer Method—1968. *ESSA Technical Report*, ERL 79-ITS 67, July 1968.
- [37] MAGRAB, E. B., and BLOMQUIST, D. S. *The Measurement of Time Varying Phenomenon*. Washington, DC: Wiley Interscience, 1971.
- [38] MAHLUM, RONALD W. *Flight Measurements of Aircraft Antenna Radiation*. Final Report, USAF Flight Test Center, Edwards Air Force Base, CA AFFTC-TD-75-3, Oct 1975.
- [39] MASSEY, Jr, FRANK J. The Kolmogorov-Smirnov Test for Goodness of Fit. *American Statistical Association Journal*, Mar 1951, pp 68–78.
- [40] MATTOX, W. How to Select Minimum Sweep Time for Plotter Readout. *EDN/EEE*, vol 16, no 14, July 15, 1971, pp 46–47.
- [41] MIR, S., and WHITE, D. R. J. Building Attenuation and the Impact on Product Susceptibility. *IEEE Electromagnetic Compatibility Symposium Record*, July 1974, pp 76–84.
- [42] OKUMURA, Y., OHMORI, E., KAWANO, T., and FUKADA, K. Field Strength and its Variability in VHF and UHF Land-Mobile Radio Service. *Review of the Electrical Communication Laboratory*, vol 16, no 9–10, Sept 1968, pp 825–873.
- [43] RICE, L. P. Radio Transmission into Buildings at 35 and 150 Mc. *Bell Systems Technical Journal*, Jan 1959, pp 197–210.
- [44] RICE, P. L., LONGLEY, A. G., NORTON, K. A., and BARSIS, A. P. Transmission Loss Predictions for Tropospheric Communication Circuits. *National Bureau of Standards Technical Note 101*, vols 1 and 2, May 1965.
- [45] RUGGERA, P. S. Near-Field Measurements of RF Field. US Department of Health, Education, and Welfare Publication (FDA) 77-8026, *Symposium on Biological Effects and Measurements of Radio-Frequency and Microwaves*, Rockville, MD, Feb 16–17, 1977, pp 104–116.
- [46] RUGGERA, P. S., *E-Field Instrumentation and Calibration Below 500 MHz*. US Department of Health, Education, and Welfare, Publication (FDA) 77-8011, Dec 1976, *Biological Effects of Electromagnetic Waves, Selected Papers of the USNC, URSI Annual Meeting, Boulder, CO*, vol 2, Oct 1975, pp 281–296.
- [47] SHEPHERD, R. A. GADDIE, J. C., and NIELSON, D. L. *Improved Suppression of Radiation from Automobiles Used by the General Public*. Final Report, SRI International Project 2763, Jan 1975.
- [48] SKOMAL, E. N. The Dimensions of Radio Noise. *IEEE Electromagnetic Compatibility Symposium Record*, June 1969, pp 18–28.
- [49] SKOMAL, E. N. *Man-Made Radio Noise*. New York: Van Nostrand Reinhold, 1978.
- [50] SMITH, Jr, A. A. Attenuation of Electric and Magnetic Fields by Buildings. *IEEE Transactions on Electromagnetic Compatibility*, vol EMC-20, no 3, Aug 1978, pp 411–418.

- [51] SMITH, Jr, A. A. Power-Line Noise Survey. *IEEE Transactions on Electromagnetic Compatibility*, vol EMC-14, no 1, Feb 1972, pp 31–32.
- [52] SMITH, Jr, A. A. Propagation of Interference Currents on Power Mains. *Third Symposium and Technical Exhibition on Electromagnetic Compatibility*, Rotterdam, May 1–3, 1979, pp 465–470.
- [53] SMITH, Jr, A. A. Received Voltage Versus Antenna Height. *IEEE Transactions on Electromagnetic Compatibility*, vol EMC-11, no 3, Aug 1969, pp 104–111.
- [54] SPAULDING, A. D., and DISNEY, R. T. Man-Made Radio Noise, Part I, Estimates for Business, Residential, and Rural Areas. *Office of Telecommunications Report*, OTR 74- 38, Boulder, CO, June 1974 (NTIS: COM-75-10798/7).
- [55] WELLS, P. I., and TRYON, P. V. The Attenuation of UHF Radio Signals by Houses. *Office of Telecommunications Report*, OTR-76-98, Aug 1976 (NTIS: PB-258-447/2).
- [56] YATES, R. W., and WIELEBINSKI, R. Intensity-Frequency Dependence of the Radio Sky Background. *Australian Journal of Physics*, vol 19, 1966, pp 389–407.

4. Test Planning

4.1 Site Electromagnetic Environment

An electromagnetic radiation survey may consist of measurements in which the rf environment is characterized, at one extreme, by a single frequency which varies little with time and slowly with position, and at the other extreme, by composites of periodic and random emissions of many frequencies varying greatly with time and observation point. In preparation for surveying a given site, the character of the radiation environment likely to be present should be determined. Electromagnetic radiation fields will include not only emissions from licensed transmitters, but also ambient noise from both natural and unintentional man-made sources. Information on US land-based sources may be obtained from national spectrum management authorities such as the Federal Communications Commission or the area frequency coordinator of the United States Department of Defense (in Canada consult the Department of Communications). Information requests might include source, location, output power schedule, antenna height, radiation pattern, polarization, effective radiated power, and frequency. The operating duty factor may be obtained directly from the license holder. Each investigator shall supplement these data with computed radio path losses to estimate the signal strength at the survey site. Sources of information aiding this calculation are available, such as [19], [24], [36], [42], and [44].

No comprehensive cataloging of transmitters in space is presently provided by any agency. However, the International Telecommunications Union in Geneva, Switzerland, maintains a file of voluntarily reported satellite launches with emitter characteristics and orbital parameters.

Unintended man-made radio noise which may be a significant contributor from at least 10 kHz to 5 GHz is a function of locale and frequency. The mean power of this interference p_n , in watts, observed at the output terminals of a lossless antenna is expressed by an external noise figure F_a , in decibels:

$$F_a = 10 \log_{10} f_a \quad (\text{Eq1})$$

where noise factor f_a is given as

$$f_a = p_n / (kT_o B) \quad (\text{Eq2})$$

where

- B = the noise bandwidth, Hz
 k = Boltzmann's constant $1.38 \cdot 10^{-23}$ J/K
 T_o = the reference temperature of 288 K

The median value of F_a designated as F_{am} is plotted in Fig 2, [49], and [54]. Figure 2 provides an estimation of the expected levels of this type of ambient noise for four classes of locales: urban, suburban, rural, and quiet rural. These surface sources also contribute to ambient noise levels above the earth. Some experimentally determined values, as a function of altitude above the earth's surface and degree of urbanization, are shown in Fig 3. Surface generated noise intensity decreases with altitude by 2 dB within the first 300 m (at 100 MHz) and by 0.6 dB/km above 300 m (at 100 MHz). The initial 2 dB decrease is less than the observed variability in surface noise levels. Figure 3 also displays observed surface median values F_{a0} , as derived from measurements in several world-wide urban areas, [54]. Upper bounds are shown in terms of the 84 percentile and 97.7 percentile geographical maximum values to be expected. Maximum weekday diurnal variations, due to changes in human activity, are shown in Fig 4. The degree of variation is primarily dependent upon frequency, not upon locale.

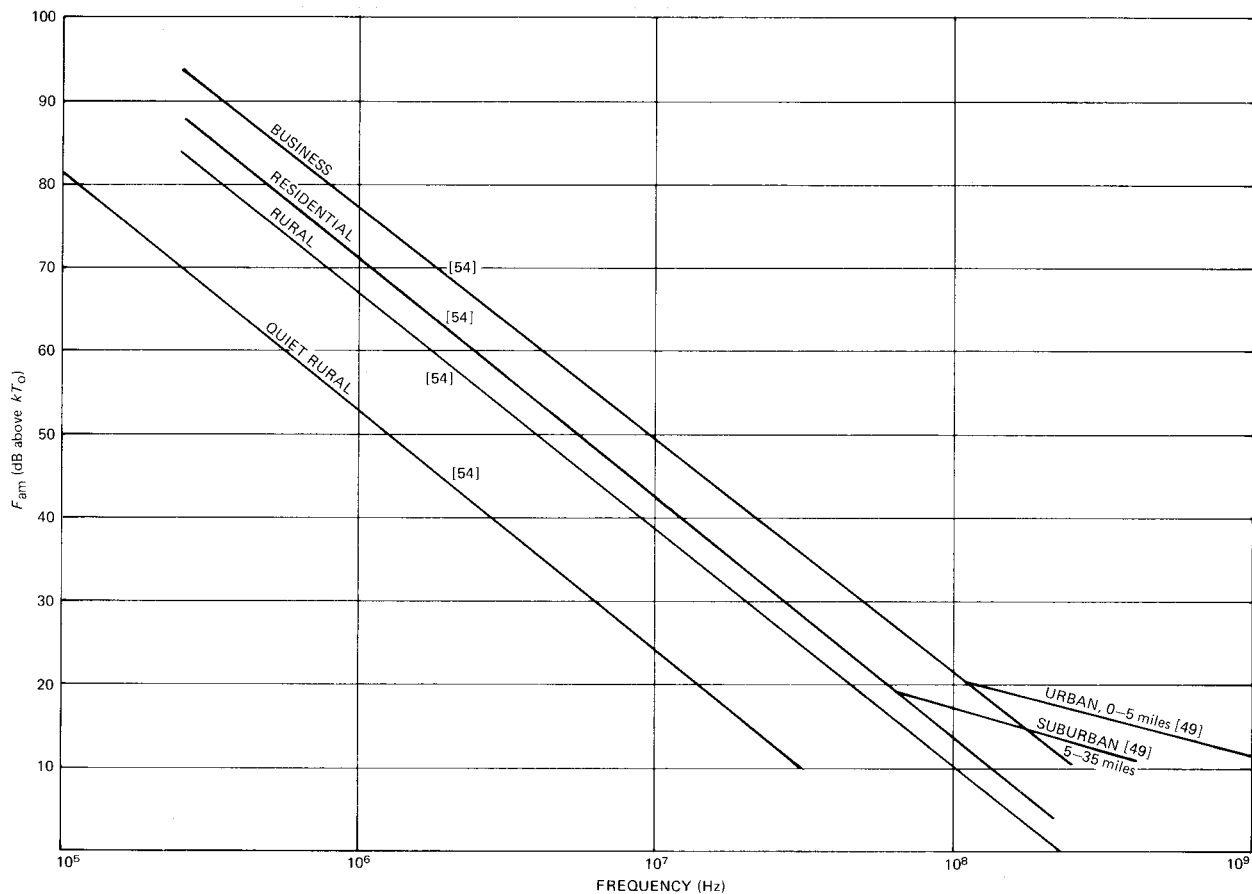

Figure 2— Median External Noise Figure for Surface Man-Made Incidental Median Ambients

Naturally occurring rf noise from atmospheric disturbances and from solar system and galactic sources may contribute significantly to background levels, especially in the quieter remote and rural locations. Figure 5 illustrates contributions above 10 MHz from several of these sources [22], [23], [25], [31], [49], [54], and [56]. For a survey application in which either antenna gain g , or the effective aperture area A (m^2), of the survey antenna is known, the

noise power flux density S , plotted in Fig 5 may be used to compute the ambient noise power density P_n , (dB) for an antenna of gain g by means of

$$A = g\lambda^2/4\pi \tag{Eq3}$$

$$P_n = S + 10 \log_{10}A, \text{ dB/Hz} \tag{Eq4}$$

and therefrom, F_a by using

$$F_a = P_n + 204 - 10 \log_{10}B \tag{Eq5}$$

Except for spatially distributed galactic noise, the source shall fall within the useful beam of the observing antenna to contribute significantly to the ambient level being recorded.

Naturally produced ambient noise levels at frequencies below 25 MHz are supplemented or dominated by atmospheric noise which is dependent upon frequency, location, time of day, and season [48]. The atmospheric noise contribution should be added to values determined from Fig 5 (for frequencies less than 25 MHz).

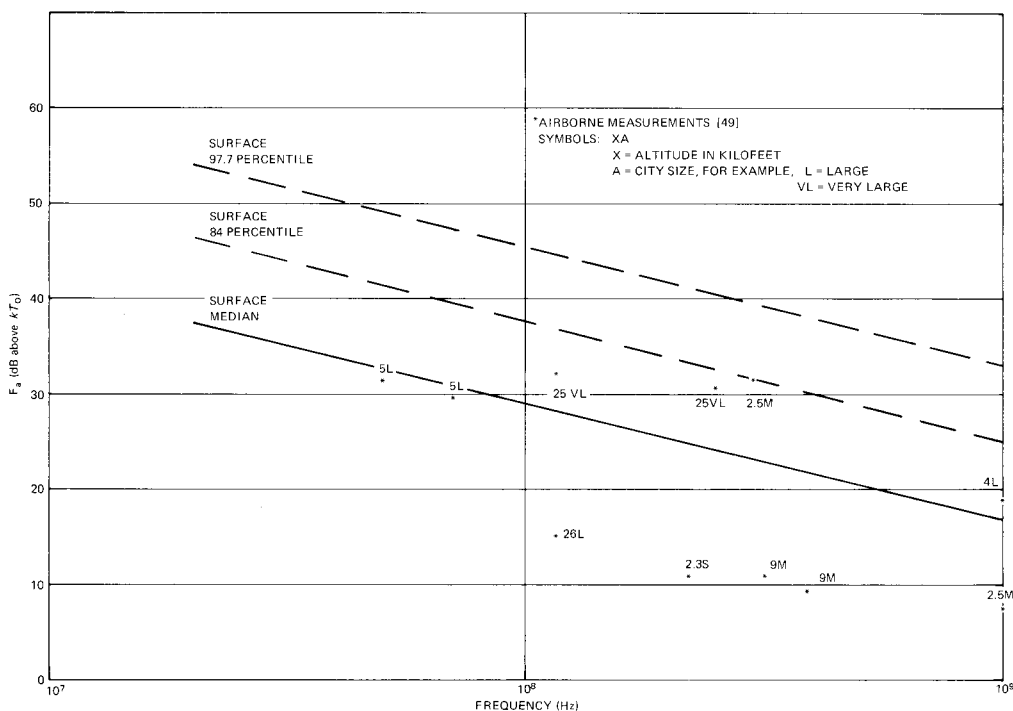

Figure 3— External Noise Figure for Man-Made Incidental Radio Noise as a Function of Urban-Center Size, Altitude of Measurement, and Frequency with Surface Distribution Percentile

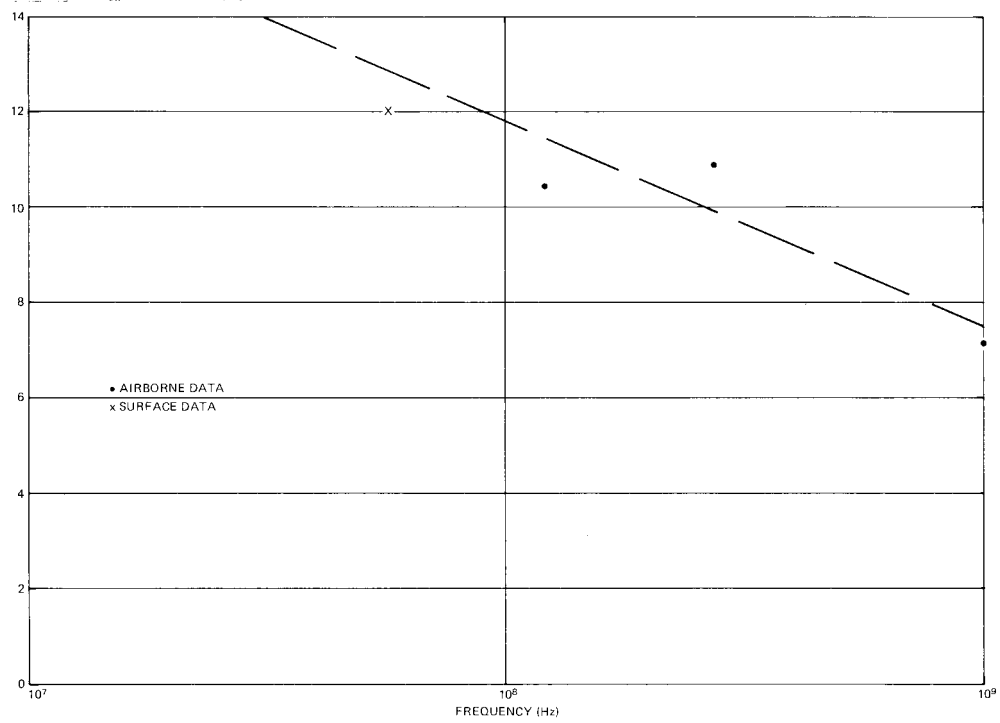

Figure 4— Maximum Weekday Diurnal Variation in F_a of Man-Made Noise [49]

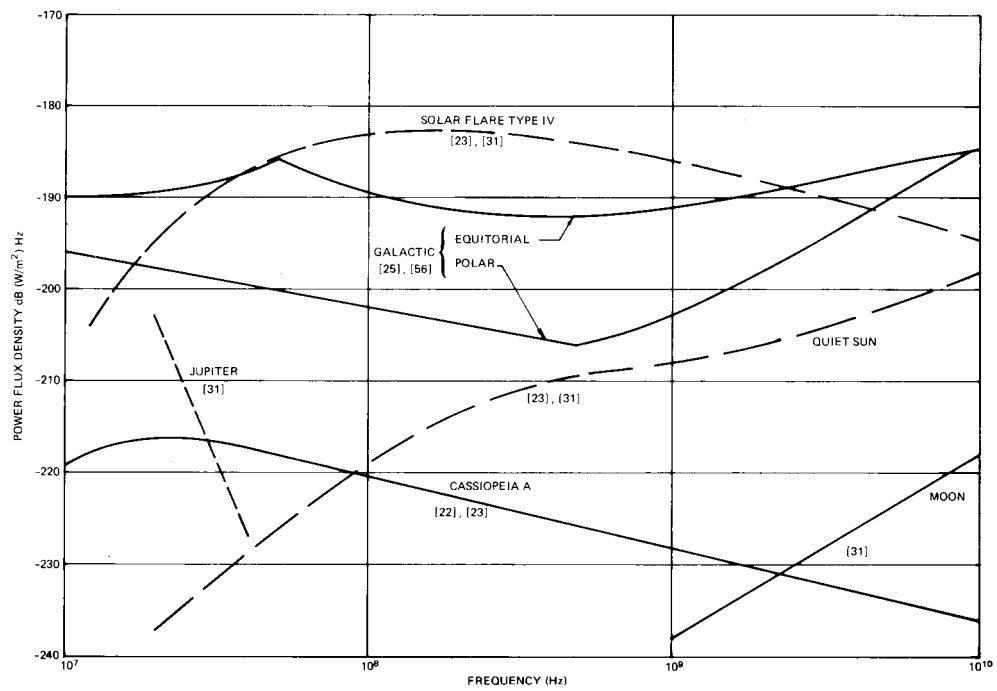

Figure 5— Power Flux Density for Natural Noise Sources

4.2 Data Sampling

The survey of sites where essentially continuous radiation from local transmitters predominate may be conducted over shorter test periods than those where natural or man-made random emissions contribute significantly. A single 24 h sampling period is recommended to establish the variability of a periodic radiation source. If weather-dependent effects are expected to be significant, the survey duration should be long enough to include weather cycle extremes. Average power samples of 3 min should be recorded at least once an hour. Each 3 min sample provides a mean power level. The hourly power levels are constructed to determine a daily cyclical pattern.

Site conditions dominated by random noise sources require much longer observation intervals (listed in Table 1). A minimum test duration of two weeks ensures repeatable diurnal measurements. When man-made noise is dominant, sampling intervals should be spaced 1 h apart with 3 min minimum sample lengths. To ensure statistical confidence, a minimum of 11 data points is recommended. Referring to Table 2 and Fig 6, 11 samples are seen to yield an uncertainty of $\pm 0.352/\Gamma$ in a population mean at a confidence level of 0.9 (a level of significance of 0.1) [39]. Here Γ is the slope of the cumulative distribution formed by the set of 11 hourly samples in the vicinity of the median x_m . By increasing the 3 min sample set size above 11 the uncertainty interval about the set median containing the population median may be reduced in accordance with Table 2. As an example, suppose that a 3 min sample size of $N = 35$ data points were recorded. If a 90% confidence is desired, enter Table 2 at $\alpha = 0.1$ and $N = 35$ to obtain $d(35) = 0.21$. The calculated median x_m of the 35 points is expected to lie within $\pm d\alpha(35) = \pm 0.21/\Gamma$ of the true population median, with a 90% confidence. By plotting the cumulative distribution of the set of 35 measured values, x_i , the value of the slope Γ is obtained allowing the limits $\pm 0.21/\Gamma$ to be calculated. These results are distribution independent, that is, they are not a function of the form of the distribution function characterizing the observed data. The only constraint that applies is that the data shall be reasonably representable by a continuous distribution function.

Table 1— Site Survey Observation Intervals

Predominant Type of Electromagnetic Radiation	Total Duration of Survey (d)	Inter-Sampling Interval (h)	Minimum Sample Length (min)	Minimum Number of Data Points per Sample
Periodic	1	1	3	11
Random noise natural sources	14	4 0600–2400	3	11
Man-made	14	1 Local Time	3	11

Table 2— Critical Values $d\hat{\alpha}(N)$, of the Maximum Absolute Difference between Sample and Population Cumulative Distributions

Sample Size (N)	Level of Significance ($\hat{\alpha}$)*				
	0.20	0.15	0.10	0.05	0.01
1	0.900	0.925	0.950	0.975	0.995
2	0.684	0.726	0.776	0.842	0.929
3	0.565	0.597	0.642	0.708	0.828
4	0.494	0.525	0.564	0.624	0.733
5	0.446	0.474	0.510	0.585	0.669
6	0.410	0.436	0.470	0.521	0.618
7	0.381	0.405	0.438	0.486	0.577
8	0.358	0.381	0.411	0.457	0.543
9	0.339	0.360	0.388	0.432	0.514
10	0.322	0.342	0.368	0.410	0.490
11	0.307	0.326	0.352	0.391	0.468
12	0.295	0.313	0.338	0.375	0.450
13	0.284	0.302	0.325	0.361	0.433
14	0.274	0.292	0.314	0.349	0.418
15	0.266	0.283	0.304	0.338	0.404
16	0.258	0.274	0.295	0.328	0.392
17	0.250	0.266	0.286	0.318	0.381
18	0.244	0.259	0.278	0.309	0.371
19	0.237	0.252	0.272	0.301	0.363
20	0.231	0.246	0.264	0.294	0.356
25	0.21	0.22	0.24	0.27	0.32
30	0.19	0.20	0.22	0.24	0.29
35	0.18	0.19	0.21	0.23	0.27
over 35	$\frac{1.07}{\sqrt{N}}$	$\frac{1.14}{\sqrt{N}}$	$\frac{1.22}{\sqrt{N}}$	$\frac{1.36}{\sqrt{N}}$	$\frac{1.63}{\sqrt{N}}$

* $\hat{\alpha} = 1 - \text{confidence level}$ NOTE — Values of $d\hat{\alpha}(N)$ so that $p_r[\max|S_N(x) - F_0(x)| > d\hat{\alpha}(N)] = \hat{\alpha}$, where $F_0(x)$ is the theoretical cumulative distribution and $S_N(x)$ is an observed cumulative distribution for a sample of N .

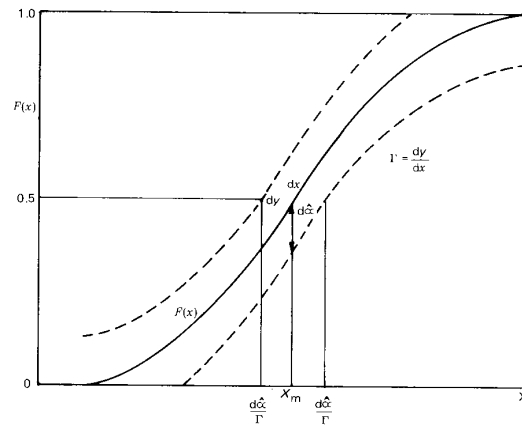

Figure 6— Distribution Function $F(x)$

4.3 Documentation of Site Characteristics

Any metallic, or, more generally, conducting object can affect an electromagnetic field. The degree of the effect is dependent upon the frequency of radiation and the size of the object. Reflection, scattering, and diffraction are primary mechanisms by which field measurements are upset. It is important to document any site features likely to affect the data. A scaled map should be used to record such features. Major reflecting surfaces and conductors, both above and below ground level, at least 100 m (up to one wavelength) from the site should be shown. Obstacles shown should include

- 1) Above ground structures, such as buildings (note type of construction), metallic fences, and broadcast antennas
- 2) Suspended cables, such as power, telephone, and those used for cable television (note the number of cables, routing, location of drop wires, power-line ratings, and the type, number, and location of supporting structures)
- 3) Underground conduits for water, power, gas, oil, etc
- 4) Other major obstacles associated with the terrain, including foliage (note density)

Photographs should be taken to document major features of the region.

Specific rf sources should be documented and located on the map, including known active transmitters which are considered primary sources. Local noise sources not specifically identified by a licensing agency should also be documented. The latter may have to be located by inspection of the area or by radio direction finding. For each specific rf source, information concerning schedule of operation, time pattern of emission, radiated power, antenna directivity, type of modulation, and signal polarization should be tallied.

5. Site Survey Procedures

5.1 General

Electromagnetic site surveys may be grouped into two general classifications: interior and exterior. Interior locations consist of sites within buildings and all man-made inhabitable structures (including mines) while all other sites fall within the exterior category. It is essential to monitor the bands of interest within and somewhat beyond the principal frequency limits of interest by the use of headphones, speaker, or oscilloscope, or a combination of these (preceded by a tunable radio receiver), before and during the period of measurement. Precautions should be taken to ensure that the measuring and monitoring equipment does not affect the electromagnetic fields. Local field disturbances may be detected by altering the location of the monitor relative to the antenna and noting any changes in measured output.

Table 3 lists the audible sounds of interfering sources commonly encountered in many site surveys.

The instrumentation required to conduct a survey is a field-strength meter with an appropriate detector [1]. The basic field-strength meter may be incorporated into a semiautomatic or automatic measurement system under control of a microprocessor for data collection and analysis.

Table 3— Audible Sounds of Interfering Sources

Receiver Audible Output	Character of Interference	Possible Source or Mechanism
Reduced noise level (or steady tone with BFO operating)	Carrier (only)	Co-channel, spurious intermodulation
Pulsed variation in noise level (or pulsed tone with BFO operating)	Undesired cw or digital transmission	Adjacent channel, cochannel, spurious, intermodulation, cross-modulation
Pulsed variation in noise level (two pulsed tone with BFO operating)	Undesired RTT (FSK) transmission	Adjacent channel, cochannel, spurious, intermodulation, cross-modulation
Added normal or distorted voice	Undesired voice transmission	Adjacent; channel, cochannel, spurious, intermodulation, cross-modulation
Whistling or squealing	Undesired transmission or intermediate frequency oscillation	Adjacent; channel, cochannel, spurious, intermodulation, cross-modulation, parasitic if oscillation
Rapid variation in noise level (or several pulsed tones with BFO operating)	Undesired facsimile transmission	Adjacent channel, cochannel, spurious, intermodulation, cross-modulation
Steady tone or whining	High-rate periodic pulses	Radar, rotating machines
Buzzing	Medium-rate periodic pulses	Buzzer, vibrators
Popping	Low-rate periodic pulses	Ignition systems, magnetos
Frying	High-rate random pulses	Electric arcs, continuously arcing contacts
Sputtering	High-rate random pulses	Arc welders, arc lamps, diathermy
Clicking	Low-rate random pulses	Code machines, electric calculating machines, mercury-arc rectifiers, relays, switches, teletypewriters, thermostatic controls, electric typewriters
Crackling	Continuous	Static or corona discharges
Crackling	Discontinuous	Arc discharges, power lines
Sharp crackle	—	Ambient noise
Crashes	Sporadic	Atmospheric
Hissing	High pitch	Galactic
Low tone	Periodic	Power line

For detailed analyses and quantitative assessments of spectral distribution data recordings should be made on magnetic tapes, XY plotters, or displayed on oscilloscopes. Stripchart recorders and oscillographs may be used for the display of

low-frequency signals, while oscilloscopes should be used to display and photograph broadband, high-frequency signals.

Spectrum analyzers may be used to identify specific sources of interference by examining the harmonic content, the spectrum rolloff, and the relative magnitudes of the spectral components. When automatic or manually operated frequency sweeping equipment is used, the upper and lower band limits should be set at points 10% below and above the frequency range of interest. The rate R , to be used when manually performing the frequency sweep with a spectrum analyzer incorporating a crt display should not exceed

$$R \leq B^2/3 \quad (\text{Eq6})$$

where

$$B = 3 \text{ dB bandwidth of the detection filter}$$

NOTE: Automatically swept spectrum analyzers contain provisions for warning the operator of, and preventing the use of, unacceptably rapid rates that reduce the detection sensitivity and yield false signal frequency identification.

Identification of the various contributing radio-frequency sources may necessitate reducing one or more dominating signals by filtering, antenna reorientation or displacement, or by measurement rescheduling.

Measurement scheduling should accommodate

- 1) Normal operating hours of electrical and electronic equipment and broadcast transmitters
- 2) After-working-hours period when usage of equipment is minimal
- 3) Post-sunset interval when some broadcast transmitters operate at reduced power or cease transmission
- 4) Midnight-to-sunrise hours when some broadcast transmitters are inactive and when electrical usage and vehicular traffic are low

The temporal variability of man-made and atmospheric radio noise sources that will likely affect any measurement location should be assessed beforehand [14], [49].

Prior to making site measurements, laboratory calibration across the frequency band of interest is required of any receiver, detector, and recorder. A similar calibration shall follow the measurement sequence or shall occur at a time subsequent to the initial calibration equal to the stability time constant of the instrumentation.

Paper and magnetic tape recorders should be annotated with time, test description, and measurement designation per channel. Continuous annotation shall be maintained to accommodate changes in data during the test sequence.

With the visual recording equipment operating, the antenna cable disconnected at the receiver input, and the input terminated in its characteristic impedance, the motion sensitivity of each piece of equipment in the system should be checked to detect and eliminate sources of data anomalies.

Since the time to perform a spectrum scan may be lengthy, consideration should be given to the trade-off between scanning speed and noise bandwidth when using automatic or semiautomatic field-strength meters driving a permanent copy plotter. The minimum time t_m , to scan a frequency interval Δf is approximated by

$$t_m = \frac{4\hat{D}\Delta f}{S_r B} \quad (\text{Eq7})$$

where

S_r = the signal amplitude slew rate of the plotter

\hat{D} = the amplitude deflection of the plotter

B = the noise bandwidth, Hz [40]

If resolution can be sacrificed, it may be possible to reduce the time required for a scan. Receiving equipment gain variability as a function of frequency shall be compensated for and included in the resulting data of a spectrum scan. Note that Eq 6 places a lower bound on scan time for a fixed value of Δf than does Eq 7.

A final check of all ground points on measuring instruments, field test platform, and the vehicle should be made before measurement activity begins.

5.2 Exterior Location Considerations

5.2.1 Introduction

When the potential siting of a facility is the purpose of a site survey, determination of the time variability of the noise environment becomes essential. In addition to the test periods and measurement intervals presented in Table 1, the experimental plan should include a repeat investigation after six months up until two years. As an alternative, data comparisons with archival data for the specific or a similar location should be made. Detection of long-term variations in ambient radio-frequency levels are only possible in this manner.

5.2.2 Measurement Location

If man-made noise is likely to cause radio performance degradation at the survey site, comparison measurements should be made at a quiet reference site remote from any possible noise source. The ambient noise should be recorded at the quiet reference site. All measurement locations should be typical of the area based on land-use; examples include residential communities, industrial areas, parks, urban districts, and rural zones. Locations should include those places containing power lines, electrical substations, factories, and vehicular traffic. Careful selection of sampling locations is necessary to accurately reflect the noise levels of the area.

For investigations associated with the siting of communications receivers, measurements should be made at the intended receiving antenna location, replicating—as nearly as possible—the operational antenna arrangement. Mutual coupling between the survey antenna and local facilities shall be carefully accounted for or minimized. If man-made noise is likely to cause radio performance degradation at the survey site, comparison measurements should also be recorded at a quiet reference site remote from any possible noise source.

5.2.3 Antenna Considerations

At frequencies below 30 MHz, the antenna for noise measurements should be vertically polarized and have an omnidirectional azimuthal pattern. When measuring weak signals, for example, radio noise, the antenna with the smallest antenna factor (the largest gain) should be used to obtain the greatest sensitivity under conditions of minimum noise level. Between 10 kHz and 30 MHz, the 9 ft rod, a vertical monopole, is the most sensitive commercially available antenna. Above 100 MHz, and into the superhigh frequency (shf) band, a discone, a monopole, or a half-wave dipole antenna cut for each frequency is preferred. The commercially available directional antennas, such as log-spirals and horns should not be used for man-made noise surveys unless the source locations have been well defined and the directional azimuthal pattern of the antenna can be accurately oriented towards them.

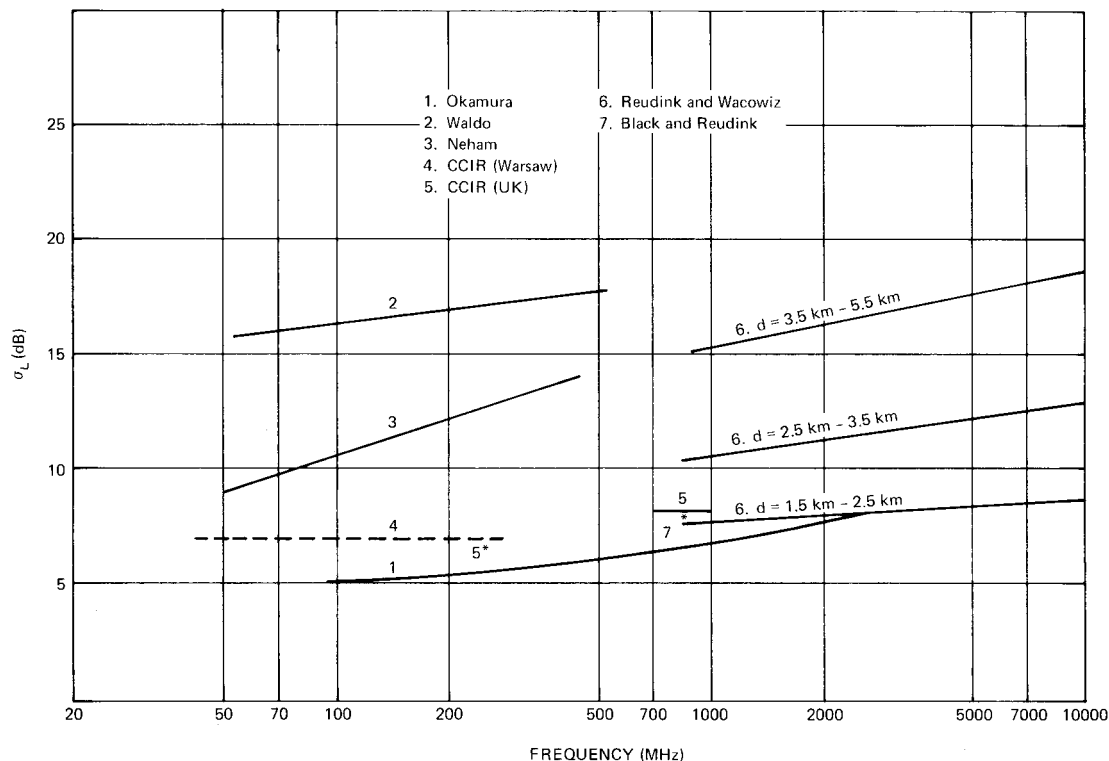

Figure 7— Standard Deviation of Location Variability σ_L , as a Function of Frequency in Urban Areas

At a selected site, interpretation of the field strength dB (ref 1 W) or received power densities arising from commercial and broadcast transmitters operating above 20 MHz is affected by location variability, that is, the signal change that accompanies any displacement of the receiving antenna. When a test antenna is moved within a small area of approximately 2500 m², the mean of the observed power in dB (ref 1 w) has been observed to be normally distributed about the mean received power of the general area. This log-normal distribution of local mean power about the area mean applies equally to reception in urban, suburban, and rural areas. The degree of urbanization however influences the statistical moments of the data. Furthermore, the mean and variance of the observed power are also affected by the terrain irregularity.

The mean value of the received signal level is a function of the radiated power of the signal source and the intervening path loss; therefore, it is unique to each site survey. The variance of the local signal power is determined principally by the frequency, terrain irregularity, and building density in the vicinity of the receiving site and, to a lesser degree, by the receiving antenna polarization, soil electrical properties, and atmospheric conditions. A detailed analysis of the data of a number of studies of location variability of transmission loss at 20 MHz to 10 GHz has been summarized in [35]. Figure 7 gives the standard deviation of location variability σ_L , as a function of frequency for urban areas [28]. The lower values are typical of conditions in Tokyo, Warsaw (CCIR, 1969), and medium-sized cities and towns in England, Scotland, Wales, and other countries. The higher estimates are for the canyon-like streets of Manhattan or heavily built-up areas with many trees.

5.3 Interior Location Considerations

5.3.1 Introduction

The main point to remember when making interior measurements is that open field principles do not necessarily apply. The proximity of conducting materials to the measurement site may distort the antenna pattern. The radiated fields may be perturbed by obstacles in the vicinity. There is also the possibility of mutual coupling occurring between the antenna, metallic objects, and the instruments. These interactions are further aggravated by the interior space acting as a resonant cavity or poorly shielded room at certain frequencies. Hence, interior measurements may display larger variations than exterior measurements.

A detailed floor plan is needed for future reference. This should include overall dimensions of the area and additional parameters such as

- 1) Window, door, existing equipment, and furniture locations
- 2) Spacing of girders and of steel reinforcement columns, especially those near the interior of the area
- 3) Power and telephone lines
- 4) Routing of power cables to the test equipment
- 5) Test point locations and distance in wavelengths to metallic structures to determine whether near or far field effects dominate
- 6) Relative elevation angles to the main lobe patterns of any transmitters in the area

Before commencing the site survey, either a current or field probe attached to a spectrum analyzer should be used to determine which of the metallic objects may be carrying radiofrequency current. Typically, interior girders, water pipes, and power conduits will be important sources of radio signals. Fields may be enhanced near interior current carrying conductors. Such local hot spots should not be selected as measurement points unless sensitive equipment may be installed in their vicinity.

It is also advisable to measure the radiated fields when the room is empty, prior to the introduction of permanent equipment. This will reduce the errors discussed previously that are caused by interactions between antennas and metallic objects. As each piece of permanent equipment is added, the effect should be checked with a calibrated probe, such as a small dipole. Very small dipoles have been designed by the National Bureau of Standards and others [32]. Broadband power density meters and probes are also available.

When the room is completely filled with permanent equipment, indicate on a floor plan the paths of all interconnecting cabling between electronic test equipment, particularly digital buses using standard interfaces as described in ANSI/IEEE Std 488-1978 [12]. Several sites should be selected in the area. Each site may give a different spectral distribution of the radio fields. Internal transmitters should not be operating during the measurements. (Fire inspectors and security officers are typical users of handheld narrowband fm transceivers.)

Interior interference may arise from sources outside the building such as that from broadcast transmitters. Sources inside the building may include low-voltage electrical equipment [2], [49], data processing equipment, and office equipment [13].

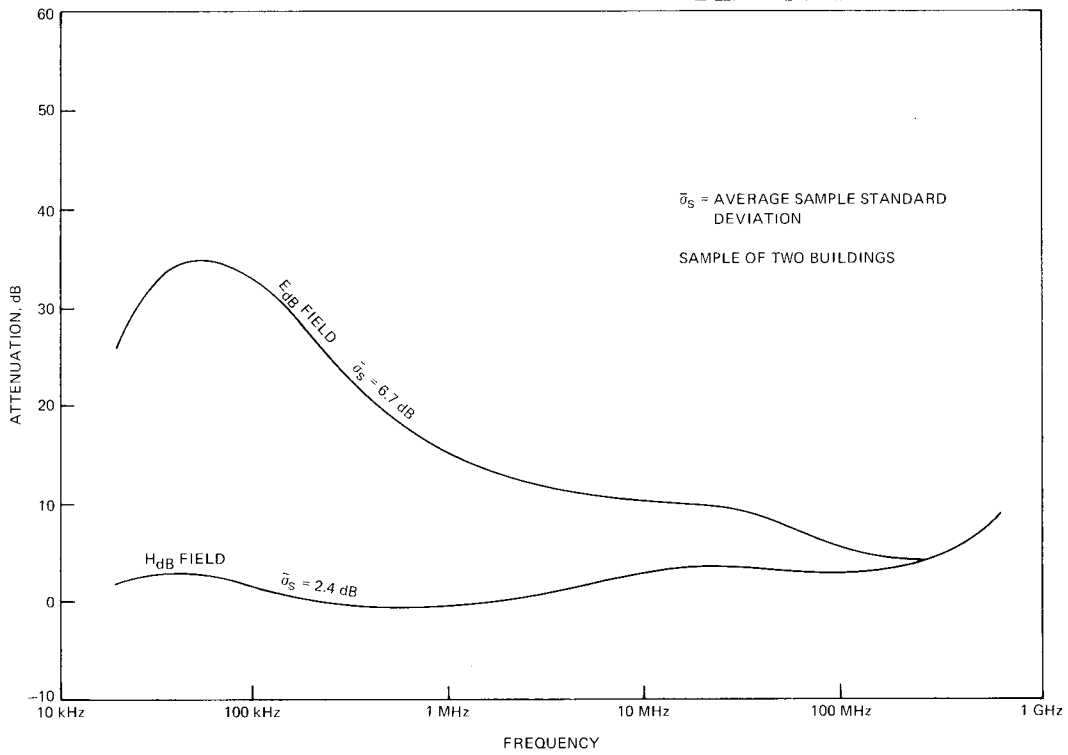

Figure 8— Building Attenuation for Single-Family Residences

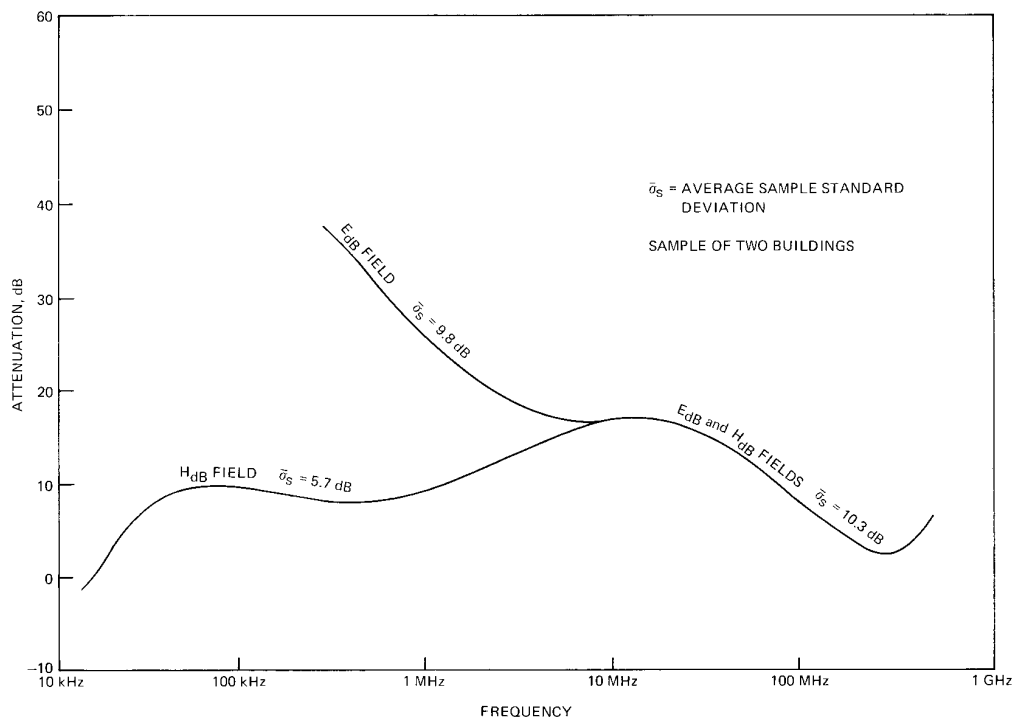

Figure 9— Building Attenuation for Commercial Single-Story Concrete-Block Buildings

5.3.2 Indoor-Survey Procedures

The exact procedure to be followed in an indoor measurement survey will depend upon the particular application of the data to be obtained. The following recommendations are intended as a guide that can be tailored to satisfy individual requirements.

Several site selections should be included in the survey consisting of

- 1) The four quadrants of the building floor
- 2) All floors of the building including the basements
- 3) Various distances from the walls, both interior and exterior, and the center of the occupied area
- 4) Window areas and doorways

The location and characteristics of the radiation sources within the building, such as low-frequency paging equipment and industrial, scientific, or medical equipment, should be determined. Communication antennas on the building should be noted.

5.3.3 Antennas for Indoor Surveys

5.3.3.1 Antenna Size

Three factors tend to restrict the size of antennas which may be used indoors

- 1) Available space
- 2) Nonuniformity of fields caused by surface reflections
- 3) Nearby metal objects

These considerations limit the choice of antennas for indoor measurements and have the effect of excluding 9 ft rod antennas and half-wavelength, tuned dipole antennas for frequencies below 100 MHz.

5.3.3.2 Antenna Placement

Due to possible effects on antenna impedance and pattern, antennas should be placed as far as possible from all metal objects. In general, the antenna should be located in the approximate center of a room or hallway, midway between floor and ceiling. In large rooms, this is not as critical as it is in confined areas. In high-ceiling rooms, the minimum height of the center of the antenna above the floor should be approximately 1.5 m. Rod antennas, with their associated ground planes, may be mounted on the floor, or raised to approximately 1.5 m above the floor.

Reflections of the electromagnetic fields from metal building structures and other metal objects may cause standing waves (spatial nulls and peaks) at the higher frequencies. If these cannot be avoided, the position of the antenna and the antenna height should be varied in small steps, $\leq \lambda/4$, to achieve a maximum signal.

5.3.3.3 Antenna Orientation

The orientation of an antenna will depend upon its particular application, that is, what information about spatial properties of the field is required. The following recommendations are intended as a guide for proper orientation:

- 1) Rod antennas should only be oriented vertically. Since they are omnidirectional in the horizontal plane, no rotation in azimuth is necessary.
- 2) During the course of a survey at each location, loop antennas should be mounted in three orthogonal positions (X, Y, and Z axes). In one position the plane of the loop should be horizontal. The remaining position selections should be orthogonal to the first and to one another. The spectrum should be scanned for each orientation of the loop. If the magnitude of the magnetic field vector is required at a particular frequency, the azimuth and elevation angles of the loop shall be varied for maximum signal reception.

- 3) Dipole antennas should be mounted in a manner consistent with their length, the location of obstacles, and the dimensions of the test area when interior locations are studied. Horizontal mounting should always be employed. Vertical orientation should also be used when the test location and dipole lengths permit.
- 4) Planar log-periodic antennas, horn antennas, and dish antennas should be oriented for both horizontal and vertical polarizations at the desired elevation and azimuth angles, and the spectrum scanned in each polarization. To orient these antennas for maximum response at a single frequency, the polarization, azimuth, and elevation angles shall be varied.
- 5) Conical log-spiral antennas should be oriented at the desired azimuth and elevation angles prior to scanning the desired spectrum. At a particular frequency, the azimuth and elevation angles should be varied for maximum signal strength detection.
- 6) Effects of building structure on penetration of remotely generated signals should be assessed when interpreting interior measurements and when planning for high sensitivity studies. The magnitude of building attenuation is a function of frequency, building construction, location within a building, and field components [26], [41], [43], [50], and [55]. Results for the three most commonly encountered types of structures (single family residences, small commercial buildings, and multistory office buildings) are summarized in Figs 8, 9, and 10. The variability of the data is accounted for by differences in polarization, wall construction, insulation, and interior location. The data representing multistory office buildings apply to all floor levels in the structure.

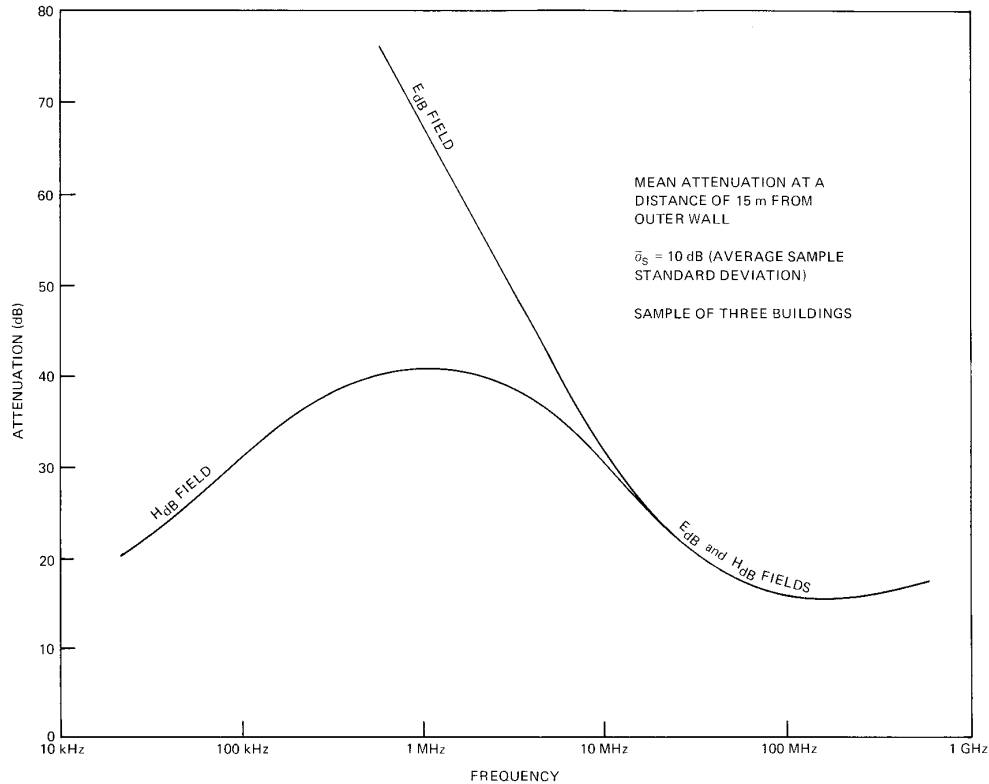

Figure 10— Building Attenuation for Multistory Office Buildings at a Distance of 15 m from the Outer Wall

5.4 Power-Density Surveys, Interior and Exterior Locations

Power-density evaluation studies commonly are performed when the potential levels of radiation may be expected to pose a threat to human health. Safety levels and recommended procedures are available. See [3], [4], [18], [21], [33]. The following precautions should be taken when making these measurements:

- 1) A high-power transmitting antenna should never be pointed directly at monitoring personnel during a power measurement
- 2) The transmitting antenna should be moved slowly to prevent accidental excessive exposure of personnel
- 3) When recommended levels of exposure to monitoring personnel may be exceeded (10^{-2} W/cm² for 6 min/h) remote detecting devices should be used
- 4) Protective clothing or shielded vans should be used when high exposure levels are possible
- 5) Occupancy of an area shall be controlled while measurements are being made

5.5 Surveys of Power-Distribution Systems

Many applications require quantitative data on the radio-frequency voltages and current on power-distribution systems. Power-line carrier systems, for example, are limited in range by the noise on the lines and by the insertion loss of the path. In the vhf region, fm receivers commonly use the power line in lieu of an antenna in urban and suburban environments. In this case, both the level of the desired fm signals and the background noise levels on the power-distribution system (or power mains) determine the performance of the receiver. In the field of electromagnetic compatibility, surveys of noise on power-distribution systems are often required to prevent or eliminate problems when susceptible systems are required to share the mains with emitters of interference.

The spectral/temporal variables required to characterize the voltages and current on power-distribution systems are identical to those used for radiated electromagnetic fields, for example, F_a , APD, ACR, PSD, PDD, etc. Essentially, radiated and power-line conducted measurements differ only in the type of transducer; that is, electric and magnetic antennas for radiated measurements, and voltage and current probes for conducted measurements.

Figure 11 shows cable stub and current probe arrangements that may be used for the measurement of common-mode (cm) and differential-mode (dm) current on power-distribution systems [52]. Note that dm pickup is between the phase and neutral wires, and that the $2\ \mu\text{F}$ capacitor at the end of the cable stub presents a differential-mode short circuit. In contrast, the cm pickup current probe is placed around all three wires (phase, neutral, and safety) of the cable stub. For cm current, the cable stub can be considered an open-circuited, single-wire transmission line over a ground plane. Measured cm and dm insertion-loss curves for a number of different paths on power-distribution systems are given in [52]. Mode conversion curves are also given.

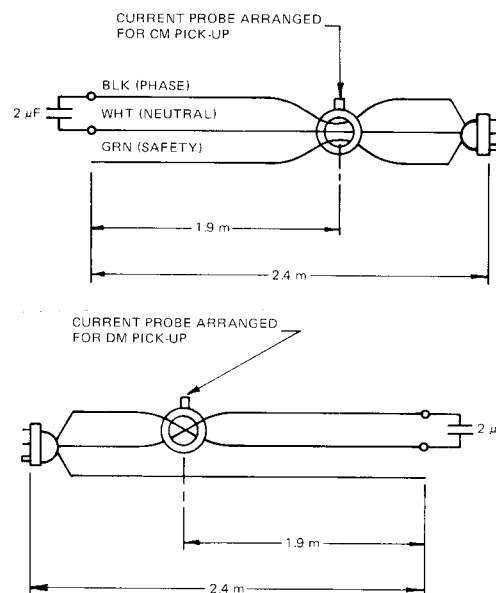

Figure 11— Cable and Current Probe Details

Expected power-line noise levels are shown in Fig 12 and [51]. In this survey, the common-mode voltage was measured, using a direct co-axial tap (that is, the coax shield was attached to the building ground at the receptacle, and the coax center conductor was connected to neutral).

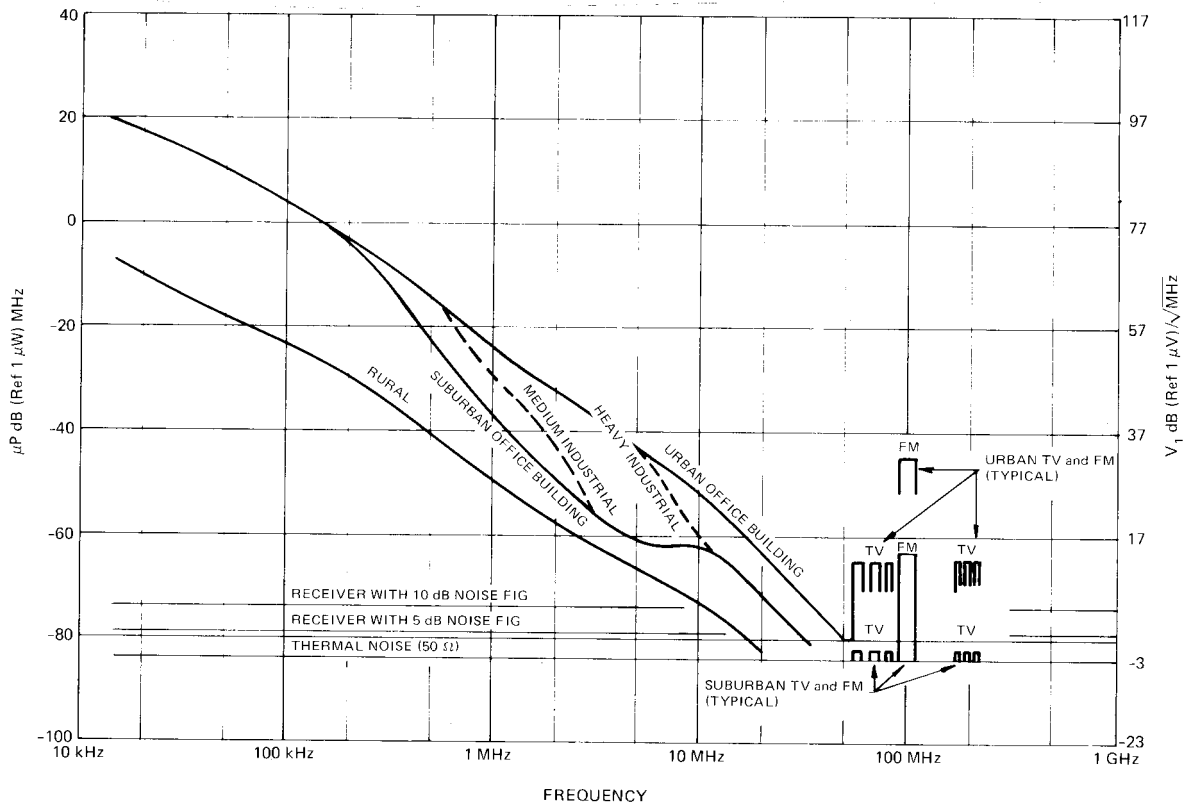

Figure 12— Power-Line Conducted Noise

6. Antennas

6.1 Introduction

The antennas recommended for measurements of electric and magnetic fields during site surveys are described hereafter and summarized in Table 4.

Antenna factors AF , as a function of frequency should be obtained from the manufacturer of each antenna.⁹

⁹If the gain G , relative to an isotropic antenna is known, the antenna factors for a matched antenna may be computed using

$$AF = 20 \log_{10} f_M - 29.8 - G, \text{ dB, for a } 50 \Omega \text{ antenna}$$

$$AF = 20 \log_{10} f_M - 31.5 - G, \text{ dB, for a } 75 \Omega \text{ antenna}$$

$$AF = 20 \log_{10} f_M - 37.5 - G, \text{ dB, for a } 300 \Omega \text{ antenna}$$

Table 4— Recommended Antennas and Probes for Various Frequency Ranges

Recommended Antenna Type	Frequency Range
Loop	20 Hz to 30 MHz
Rod (41 inch and 9 foot)	10 kHz to 30 MHz
Power density probes	10 MHz to 10 GHz
Half-wave dipole and discone	30 MHz to 1 GHz
Broadband dipole (thick and biconical)	30 MHz to 200 MHz
Log periodic (planar and conical spiral)	200 MHz to 10 GHz
Horn	1 GHz to 10 GHz
Dish	1 GHz to 10 GHz

The electric field strength E_{dB} , expressed in decibels (ref 1 V/m) is obtained from the observed signal V , expressed in decibels (ref 1 V) and referenced to the antenna output terminals by

$$E_{dB} = V + AF, \quad \text{dB} \quad (\text{Eq8})$$

The antenna output terminals are considered to be the circuit point for meter attachment. When an impedance matching transformer is included—to properly couple a meter to the antenna—its effect shall be included in the antenna factor.

A listing of the antenna factors and their frequency dependence for a large number of commercially available antennas is provided in [20].

6.2 Ground Plane and Monopole Counterpoise

When surveying with electric field sensing antennas, it may be necessary to provide an auxiliary ground plane (for example, the use of vehicular platforms when a vertical monopole antenna shall be raised above the metal surface of the vehicle). The ground plane may be fabricated from sheet metal, or metal stock of high electrical conductivity (such as aluminum), or from screen with mesh opening diameters of ≤ 0.1 wavelength at the highest frequency of interest. The antenna is always placed at the center of the ground plane. For an electric monopole, the ground plane shall be connected to the radio-frequency ground, or zero potential point, which may be an available conduit ground or a grounding stake (in the case of nonvehicular antenna mounts). The dimension \tilde{d} , of a square ground plane should lie within the interval $L_u \leq \tilde{d} \leq 10 \lambda_m$, where L_u is the largest dimension of the sensing antenna and λ_m is the free-space wavelength of the lowest measurement frequency.

6.3 Antenna Calibration Procedures

The recommended antenna system calibration procedure is as follows:

- 1) Establish a stable field at the test point using a signal generator and a vertically polarized antenna positioned 100 m to 300 m from the test antenna (which may be vehicle mounted)
- 2) Measure the field at this location with a calibrated loop or dipole antenna mounted on the test stand or vehicle
- 3) Take several measurements to ensure the field is uniform in three orthogonal directions
- 4) Replace the calibrated antenna with the test antenna plus receivers
- 5) Measure the voltage at the antenna terminals

- 6) Calculate the antenna factor AF , at each frequency from the following equation:

$$AF = MR_c + AF_c - MR_t \quad (\text{Eq9})$$

where

MR_c and MR_t = the output voltages of the calibrated and test antennas, respectively, dB (ref 1 μV)
 AF_c = the antenna factor of the calibrated antenna, dB

These measurements should be checked at several frequencies within the range of interest and at 90° bearing points when a vehicle mounted antenna is used. If bearing angle asymmetries are detected in the antenna pattern, antenna factor calibrations at 45° bearing increments should be performed at four frequencies per octave within the band of interest.

For additional information on antenna testing procedures the reader should consult ANSI/IEEE Std 149-1979 [8].

6.4 Types of Antennas

6.4.1 Loop Antenna

A shielded loop antenna, unbalanced with respect to ground, is recommended for magnetic-field-strength measurements from 30 Hz to 30 MHz. The antenna factor for a loop antenna shall yield the magnetic field strength in amperes/meter directly. Available methods can be used to calibrate the loop [15].

6.4.2 Rod Antenna

A rod or vertical monopole antenna with a metallic ground plane is recommended for vertical electric-field-strength measurements from 10 kHz to 30 MHz. A 41 in rod is preferred for all applications except for low-level fields, where a 9 ft rod should be used. A method for calibrating a simple vertical antenna is available [16] also field calibration technique for a 9 ft rod [30].

6.4.3 Half-Wave Dipole Antenna

Half-wavelength resonant dipole antennas may be used for electric-field-strength measurements from 30 MHz to 1 GHz. Since the length of a half-wave dipole shall be adjusted for resonance at each frequency, this antenna is only practical for site surveys involving a small number of discrete frequencies. In addition, below approximately 80 MHz, the physical length of the half-wave dipole may be too large for some applications, for example, measurements of vertically polarized fields and indoor measurements. In these cases, the dipole length can be adjusted to a shorter than resonant length and an appropriate adjustment made in the antenna factor for the subresonant frequency range. Dipole antenna calibration methods may be referred to [15].

The impedance of a half-wave dipole is affected by its height above the earth and its distance from nearby metal objects [28]. For vertical dipoles, the antenna impedance is also affected by stray coupling to its transmission line [53]. As a result, the actual antenna factor will differ from the free-space antenna factor when the height of the antenna above the earth or its separation from nearby metallic objects, including the transmission line, approaches one free-space wavelength. When this situation exists, the antenna factor of the dipole should be measured with a standard antenna [28] for the conditions in which it will be used.

6.4.4 Broadband Dipole Antenna

Since broadband dipoles do not require mechanical adjustment, their use is recommended for applications where measurements over a wide frequency range are required. Because of their smaller size, broadband dipoles are better suited to indoor measurements at lower frequencies than half-wavelength dipoles.

Commerically available, thick dipoles and biconical antennas cover the frequency range from 30 MHz to 200 MHz. Discone antennas are available for the range of 30 MHz to 1 GHz and should be used when the location of the radiating source is unknown.

6.4.5 Log-Periodic Antenna

Broadband log-periodic antennas are recommended for site survey applications in the frequency range from 200 MHz to 10 GHz when the source of radiation is distributed over an angle that is very large compared to the antenna beamwidth or when the location of the source is known.

Planar log-periodic antennas are recommended for investigations where it is necessary to measure both the orthogonal (vertical or horizontal) components of elliptically or linearly polarized waves. Conical log spiral antennas are recommended for measurements of circularly polarized fields of compatible polarization and for measurements of elliptically or linearly polarized fields when it is not necessary to distinguish the direction of the axis of polarization.

6.4.6 Horn Antenna

Pyramidal horn antennas are recommended for frequencies between 1 GHz and 10 GHz. The power density, electric field strength, and voltage delivered to a matched termination can be related to the power level P_r , in watts. If the power gain g , relative to an isotropic antenna is known, or has been determined [15], the power density w , of the incident wave and the electric field strength E , may be determined from a measurement of total power observed when the receiving antenna is in the far-field of the signal source using

$$w = \frac{4\pi P_r}{g\lambda^2}, \quad \text{W/m}^2 \quad (\text{Eq10})$$

The electric field strength is given by

$$E = \lambda^{-1} \left[\frac{4\pi Z_o P_r}{g} \right]^{\frac{1}{2}}, \quad \text{V/m} \quad (\text{Eq11})$$

where

$$\begin{aligned} Z_o &= \text{impedance of free space, equal to } 120\pi \Omega \\ E &= \text{volts per meter} \end{aligned}$$

The rms voltage V_{rms} , developed across the terminals of a load of resistance r , matched to the antenna output impedance is obtained from

$$V_{\text{rms}} = \sqrt{rP_r}, \quad \text{V} \quad (\text{Eq12})$$

6.4.7 Dish Antenna

Dish or reflector antennas with a horn or log-periodic feed may be used in the frequency range from 1 GHz to 10 GHz if higher gains are required than those that are available from horns alone. The expressions for power density, electric field strength, and output voltage presented for horn antennas apply equally to a dish antenna. Typical values of gain G , that are available range upward from 10 dB and are related to dish area A , antenna efficiency ϵ , and signal wave length λ by

$$g = \frac{4\pi A\epsilon}{\lambda^2} \quad (\text{Eq13})$$

where

$$0.5 < \epsilon < 0.9$$

$$G = 10 \log_{10} g, \quad \text{dB, relative to an isotropic lossless antenna}$$

6.4.8 Electric and Magnetic Field Probes

For power-density measurements two types of elements may be used: electric field probes and magnetic field probes [45], [46]. Electric field probes use either a planar array of two orthogonal short dipoles or an isotropic array of three orthogonal short dipoles. Each is designed to cover a broad frequency range (approximately 10 MHz to 10 GHz) or to operate at specific ISM frequencies (915 MHz or 2450 MHz). Power density is related to the electric field strength E , by

$$w = \frac{E^2}{120\pi}, \quad \text{W/m}^2 \quad (\text{Eq14})$$

Magnetic field probes use an isotropic array of three small orthogonal loops and cover the frequency range from approximately 10 MHz to 300 MHz. Power density is related to the magnetic field strength H by

$$w = 120\pi H^2, \quad \text{W/m}^2 \quad (\text{Eq15})$$

where

$$H = \quad = \text{A/m}$$

Many commercially available instruments are designed to indicate power density on the output meter or at the measurement port. The power-density measure is internally derived by implementing one or more of the preceding equations which are valid in the plane wave, free-space field.

Depending on the source of radiation, the particular application, and the frequency, power-density measurements will be made in the far field, the radiating near field, or the reactive near field (see Fig 13). In the far field, accurate measurements of power density can be made with both electric field and magnetic field power density probes. In the radiating near field of the source, measurements can be made with a probe or receiving antenna which is small compared with the source, if the following three conditions are satisfied [4]:

- 1) The radiation source and any scattering objects shall be in the far field of the receiving antenna of diameter \tilde{d} (that is, for a wavelength λ , the distance R , between the object and receiving antenna shall equal or exceed $2\tilde{d}^2/\lambda$)
- 2) The receiving antenna shall be removed from the radiation source and any scattering object by several *aperture diameters*, where the term *aperture diameters* refers to the largest dimension of the radiating portion of the source or scattering object
- 3) The radiation source and any sources of multipath scattering shall be contained within the main beam of the receiving antenna

In the reactive near field, neither electric nor magnetic field probes will accurately indicate power density. Measurements of power density with the two probes will differ markedly, depending on the wave impedance. For high-impedance fields, the power density indicated by electric field probes will be higher than the power density indicated by magnetic field probes. For low-impedance fields $E/H \ll 377 \Omega$, the reverse is true. At frequencies less than 100 MHz, the power deposition in biological specimens due to the magnetic fields can be dominant [34].

Procedures for the calibration of power-density instrumentation for the microwave region are documented [33]. Detailed information pertaining to instrumentation used for assessing radio-frequency hazards may be referred to [5].

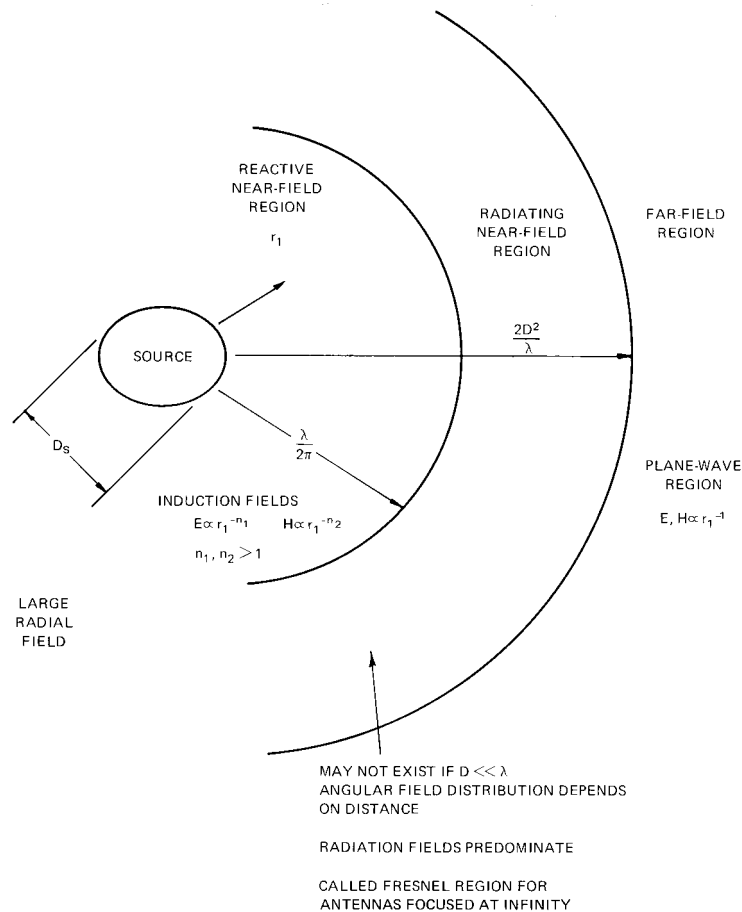

Figure 13— Source Regions

7. Measuring Equipment and Receivers

7.1 Introduction

The recommended measuring instruments and their interconnection are shown in Fig 14. Notice the use of electromagnetic shielding about the high-gain amplifier. These measuring instruments consists of an appropriately selected antenna attached to an impedance transformer or antenna coupling network, then to a variable attenuator. The attenuator is normally followed by a bandpass filter coupling to the input of an optional preamplifier. The preamplifier is used for weak signal environments under which conditions the input attenuator is set to zero. Following the preamplifier is the main receiver which is coupled to a detector of chosen function and characteristics. The detected output may be presented for visual examination by coupling to either a meter or to an oscilloscope.

For permanent recording and automatic data reduction, a magnetic tape or analog recorder is included which may be used to record either the pre- or post-detected output signals. Instrumentation needed to calibrate the receiving system consists of a calibrated impulse generator, noise source, or signal generator and frequency counter. A spectrum analyzer should be available as a measurement aid and diagnostic tool.

7.2 Attenuators

Frequently the antenna may be directly connected to the receiver and the built-in receiver attenuators will provide an adequate signal-range adjustment. However, additional radio-frequency attenuators may be required if high signal levels are encountered that could cause intermodulation and spurious signal generation in the first nonlinear element in the receiver.

Observing the signals of interest on the visual display equipment ensures that the minimum necessary attenuation has been inserted before the first stage of amplification or frequency conversion. By using the display calibration in decibels and by changing the input attenuator setting by a known increment, for example, 3 dB, a proportional change should be observed to occur in the displayed signal level. Adjustment of the expected signal level to lie within the linear portion of the amplifying system range should then be confirmed, that is, set the signal generator to the same frequency and output as previously observed and perform a stepped sequence decrease in the variable input attenuator. Identical step changes in the observed display deflection should occur.

Survey requirements may dictate the upper limit that should be placed upon the magnitude of the added receiver circuit attenuation l , that may be inserted before the first stage of amplification. The limit on attenuation l , ($l \geq 1$) is determined from the allowable increase η ($\eta > 0$) in receiving system operating noise temperature, T_{sys} , referred to the antenna terminals. The maximum value of l may be expressed as:

$$l = 1 + \eta \left[1 - \frac{T_o - T_a}{(T_o + T_e) l_c l_t} \right] \quad (\text{Eq16})$$

which is developed in Appendix A.2

where

T_o	= 228 K
	= temperature of the line attenuator
T_a	= antenna temperature
T_e	= effective noise temperature of the receiver
l_c	= antenna circuit loss
l_t	= line loss between the antenna and the receiver

For a lossless antenna, $T_a = f_a T_o$

where

f_a defined in Eq 2.

It is important to note that the insertion loss of the attenuator adds linearly to the receiving system noise figure. Therefore, its setting should be selected for the lowest value that will not cause signal distortion or the generation of intermodulation products and spurious signals in the receiver [11].

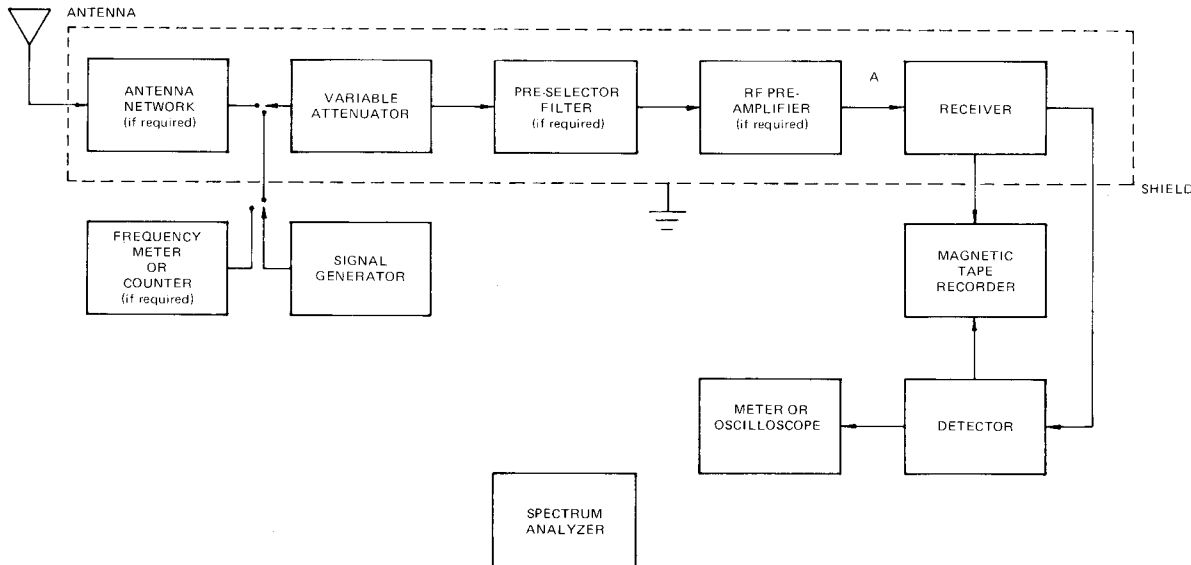

Figure 14— Measuring System

7.3 Preselector Filters

The purpose of the preselector filter is to protect the broadband preamplifier from intermodulation interference when operated in areas with strong signals. Intermodulation interference is likely to occur in site surveys in urban areas which involve land mobile frequencies. There are basically three types of filters now in use

- 1) Tunable bandpass filters, the bandwidth of which is approximately 5% of the tuned frequency setting
- 2) Fixed tuned tubular filters of larger percent bandwidth
- 3) Cavity filters with $\leq 1\%$ bandwidths

The bandwidth of the selected filter should not exceed the receiver intermediate frequency (if) minus the intermediate frequency amplifier bandwidth. The preselector filters should have an insertion loss less than 0.5 dB for use in low-signal areas.

7.4 Preamplifiers

Broadband, high dynamic range (greater than 80 dB) preamplifiers are used to improve system sensitivity for noise measurements by reducing the system noise figure. When the receiver noise figure lies between 10 dB and 20 dB, a preamplifier with a noise figure of 1 dB to 2 dB will be required to bring the overall system noise figure to 3 dB or less. For this purpose the gain of the preamplifier should be between 10 dB and 20 dB.

7.5 Tuning Range

The receivers used in a site survey should conform to MIL-STD-462-1967 [17] for the frequency range 20 Hz to 50 kHz and to ANSI C63.2-1980 [1] for 10 kHz to 1 GHz. Individual receivers should provide continuous frequency coverage for an appreciable range of frequencies. It is recommended that one of the following tuning ranges be selected:

- 1) 20 Hz to 50 kHz
- 2) 10 kHz to 150 kHz
- 3) 150 kHz to 32 MHz
- 4) 30 MHz to 515 MHz
- 5) 470 MHz to 1 GHz

Above 1 GHz the coverage should proceed in one-octave steps, for example, 1 GHz to 2 GHz, 2 GHz to 4 GHz, etc, wherever possible. If the tuning range of the receiver is divided into several bands, a frequency overlap of 2% is recommended.

7.6 Bandwidth

Determination of the minimum receiving system bandwidth required for a survey application is derived from some knowledge of the type of signals to be expected. Minimum system bandwidths are permissible when the expected signal environment consists of modulated signals or white Gaussian noise. In the case of white Gaussian noise, the observed noise power is directly proportional to receiver bandwidth therefore the bandwidth may be reduced to a value just sufficient to permit an accurate measure of the desired signal. Modulated signals should be observed in receiver bandwidths broad enough to include, as a minimum, the second order sidebands of the modulation frequency.

The average power of impulsive noise should be measured with a receiver having a bandwidth comparable to or greater than the impulse noise bandwidth of the equipment that is required to function in the environment. To measure the spectral intensity of impulsive noise the bandwidth need only be great enough to resolve the impulsive noise with respect to the thermal noise background. A receiver bandwidth of 100 MHz is necessary to observe the details of the time waveforms of impulsive noise from ignition systems. To measure peak power of impulsive noise, a bandwidth much narrower than 100 MHz can be used.

7.7 Linear Dynamic Range

The receiving system linear dynamic range, as measured between the receiver internal noise floor and the 1 dB gain compression point, should equal or exceed 50 dB to ensure that errors will be less than 1 dB in the determination of impulsive noise power.

7.8 Image and Spurious Signal Rejection

The receiver image and spurious signal rejection should not be less than 80 dB.

7.9 Receiver Noise Figure

When the frequency band of interest lies below 30 MHz, the receiving system measurable signal in urban areas is usually limited by atmospheric noise and occasionally by man-made noise. This extant ambient noise will establish the practical lower limit on the observable signal and the receiver noise figure. It is only necessary to employ a receiver with a noise factor f_r , given by

$$f_r \leq \frac{f_a - 1}{l_c l_t} \text{ for } l_{c,t} \geq 1 \quad (\text{Eq17})$$

where

$$f_a = 10^{F_a/10}$$

= external noise factor

F_a is obtained from [14], for local conditions limited by atmospheric interference or from Figs 2 and 3 for man-made noise, whichever is greater.

7.10 Antenna Transmission Line and Receiver Calibration

Most field strength receivers are equipped with either an internal sine wave or an impulse generator calibrating circuit. If an impulse generator is included, notice should be taken of the manufacturers' statement regarding its calibration. The impulse generator may be calibrated using either the true peak value or 0.707 of the peak of a sine wave.

In Fig 14 a substitution method is recommended for calibrating the input transmission line and preamplifier to point A. Figure 15 presents a recommended equipment configuration. During calibration, the input transmission line and preamplifier are replaced (by repositioning switches S1 and S2) by a low-loss length of line S whose insertion loss (and that of switches S1 and S2) has been measured as a function of frequency. A tuner may be placed as shown to reduce reactive mismatches. With line S in the circuit, a power level is measured with power meter 2 and observed by the oscilloscope attached through the isolation coupler C2. The power setting of meter 2 should be at a level P2 with most of the attenuation removed from the precision attenuator, A1. Power meter 1 is used to monitor and record the signal generator output P1, through isolation coupler C1. The precision attenuator setting is then increased to its maximum setting, and switches S1 and S2 are reset to place the receiver and its associated transmission line in the circuit. The attenuation in the precision attenuator is readjusted to a value A2 which causes the output power meter 2 to display the previous reading P2. Power meter 1 should continue to display its initial value P1. The net gain G , of the receiving system under test is

$$G = A2 - A1, \quad \text{dB} \quad (\text{Eq18})$$

An auxiliary frequency meter should be available to check the signal generator frequency. The oscilloscope should be used to observe the output signal waveform for the presence of an undistorted signal.

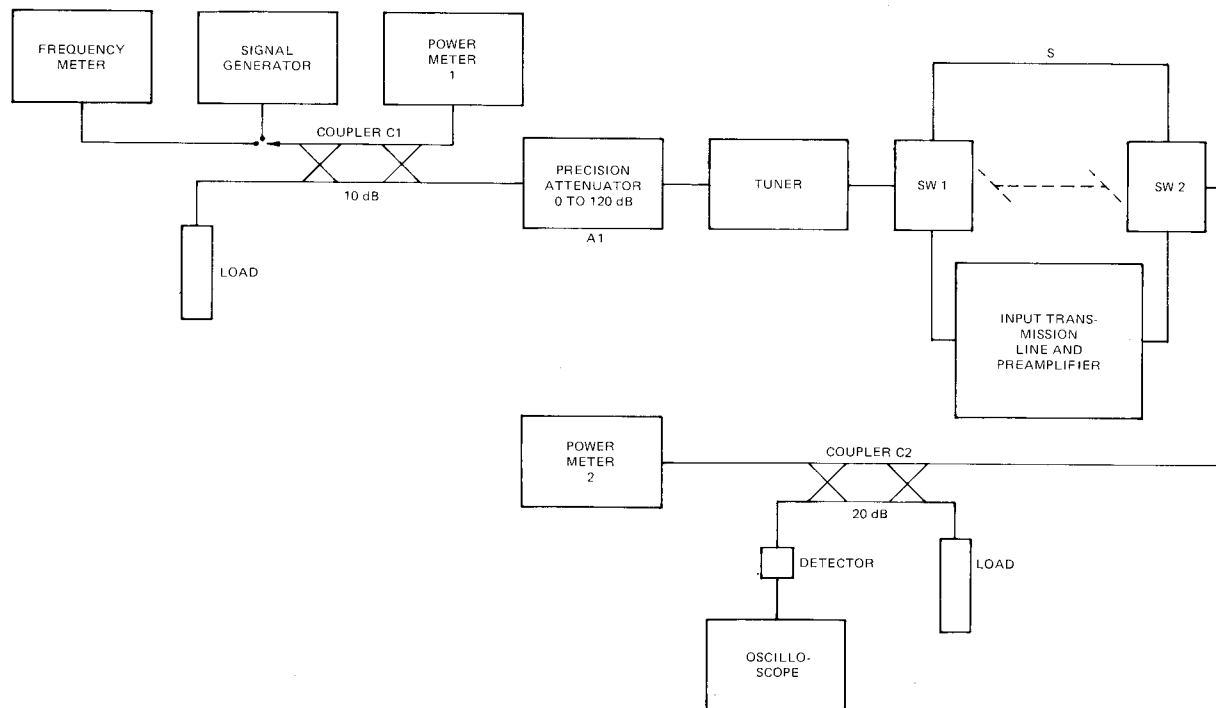

Figure 15— Calibration Equipment, Receiving System

8. Detector Functions

8.1 Introduction

Four distinguishable types of envelope detectors are available for use with site survey receiving systems

- 1) RMS voltage (average power)
- 2) Quasi-peak voltage
- 3) Peak voltage
- 4) Average voltage

The choice of detector shall be based upon some knowledge of the signal environment, the ultimate application of the survey data, and the data base available for reference and trend analyses. Of the four types, the rms voltage detector offers the most flexible measure of the radiated signal environment; the resulting measure of average power is of fundamental importance in all radio systems work. The remaining three detectors possess more limited applicability. It shall be noted that quasi-peak and peak voltage detectors have had extensive use in certain site survey applications, principally those conducted by the electric power and automotive industries and by the military. Consequently, extensive data bases have been assembled for both detectors. Quasi-peak detectors have been employed in the measurement of am broadcast signal environments; here, it has been demonstrated that the quantitative derived noise data are highly correlated with subjective annoyance effects. Peak detectors are particularly useful in measuring interference environments consisting of low repetition rate impulses that can produce errors on digital data transmission links.

The average voltage detector has been much less frequently employed in site survey studies than either peak or quasi-peak detectors; consequently, only a limited data base exists. The utility of this detector type is principally confined to

the measurement of continuous wave (cw) modulated signals and the voltage deviation V_d , which is a measure of the impulsiveness of random signals defined in Section 2..

Much of the information describing the four detector types has been drawn from [1] and is summarized here for ready reference.

8.2 Detector Types

8.2.1 RMS Voltage Detector

The rms detector should provide true rms measurement for all types of modulated signals and random waveforms. A selectable integrating time constant ranging from 0.1 s to 100 s is recommended. A minimum linear dynamic range of 100 dB is necessary for the detection of impulsive noise. The detector bandwidth should equal or slightly exceed the intermediate-frequency bandwidth of the receiver. The rms detector should be capable of measuring all types of modulated signals or noise which have a crest factor of up to 10 (20 dB).

8.2.2 Quasi-Peak Voltage Detector

The linear range of the quasi-peak detector as measured between the receiver noise floor and the 1 dB gain compression point should be

Frequency Range (MHz)	Predetection (dB)	Postdetection (dB)
0.01 — 0.15	24.0	12
0.15 — 30.00	30.0	12
30.00 — 1000.00	43.5	6

Table 5— Quasi-Peak Voltage Detector Nominal Characteristics

Frequency Range (MHz)	Charge Time-Constant (ms)	Discharge Time-Constant (ms)	Optional Discharge Time-Constant (ms)
0.01 – 0.15	45	500 ± 20%	
0.15 – 30.00	1	160 ± 20%	600 ± 20%*
30.00 – 1000.00	1	550 ± 20%	

*This discharge time constant is required for interference measurements in the United States electric-power industry.

The quasi-peak detector circuit shall have the characteristics shown in Table 5 for the frequency ranges indicated.¹⁰

The charge time-constant is the time needed, after the instantaneous application of a constant sine-wave voltage for the output voltage to reach 63% of its final value.

The discharge time-constant is the time needed, after the instantaneous removal of a constant sine-wave voltage applied to the input of the measuring set—for the output voltage to fall to 37% of its initial value.

¹⁰The parameters of the quasi-peak detector agree with CISPR (International Special Committee on Radio Interference).

In the special case of interference measurements associated with electrical power apparatus, interference meters with quasi-peak detector time constants of 1 ms charge and 600 ms discharge, and having 6 dB bandwidths of approximately 4.5 kHz, may be used at frequencies near 1 MHz. The use of these meters is acceptable because it has been established that, for the types of electrical discharges, they will read essentially the same as the CISPR meter with 1 ms charge and 160 ms discharge time constants and 9 kHz, 6 dB bandwidth [1].

Table 6— Pulse Amplitude Response

Frequency Range (MHz)	Pulse Amplitude		Repetition Rate (Hz)
	(mV)	dB(mV/MHz)	
0.015 — 0.15	13.5	139.5	25
0.150 — 30.00	0.316	107.0	100
30.000 — 1000.00	0.044	90.0	100

8.2.2.1 Pulse Amplitude Response

The pulse amplitude response of the measuring set with a quasi-peak detector, throughout the frequency, amplitude, and pulse repetition rate range specified in Table 6 (with a uniform spectrum throughout the frequency range), shall be equal to the response of an unmodulated sinewave signal of 2 mV rms produced by a signal generator of equal impedance. When the output impedance of the generator is equal to the input impedance of the measuring set, the rms sine-wave signal at the input to the measuring set will be 1 mV.

8.2.2.2 Pulse Repetition Rate Response

The response of the measuring set with a quasipeak detector to repeated impulses shall be such that, for a constant indication on the measuring set, the relationship between amplitude and repetition frequency shall be between the limits shown in Table 7.

Table 7— Amplitude Versus Repetition Frequency Limits

Repetition Frequency (Hz)	Relative Equivalent Level of Pulse (dB)		
	(MHz)	(MHz)	(MHz)
	0.01 – 0.15	0.15 – 30	30 – 1000
1000	*	-4.5 ± 1.0	-8.0 ± 1.0
100	-4.0 ± 1.0	0	0
60	-3.0 ± 1.0	*	*
25	0	*	*
20	*	6.5 ± 1.0	9.0 ± 1.0
10	4.0 ± 1.0	10.0 ± 1.5	14.0 ± 1.5
5	7.5 ± 1.5	*	*
2	13.0 ± 2.0	20.5 ± 2.0	26.0 ± 2.0
1	17.0 ± 2.0	22.5 ± 2.0	28.5 ± 2.0
Isolated pulse	19.0 ± 2.0	23.5 ± 2.0	31.5 ± 2.0

*.Indicates level is not specified for this frequency range.

8.2.3 Peak-Voltage Detector

The linear dynamic range of the peak-voltage detector as measured between the receiver noise floor and the 1 dB gain compression point should be 60 dB and have an accompanying spurious response rejection of at least 60 dB.

8.2.3.1 Direct Peak

The direct-peak detector shall have a charging circuit with a time constant in seconds that is short compared to the reciprocal of the receiver bandwidth in hertz. The discharge time constant (that is, peak hold) shall be a minimum of five times the time constant of the output indicating device. A *peak-hold* circuit with *dump* circuit is recommended. Manual control of the discharge or *dump* time constant by either a step function or continuous variable, is recommended.

8.2.3.2 Manual Slideback Peak

The manual slideback peak detector can be designed as either a back-bias circuit or a comparator circuit for determining the peak of the noise envelope. Either an aural or visual indication of the threshold point may be employed. The bias or comparator signal shall be used to control the output indication of signal level.

The peak detector shall provide a reading within 2 dB of peak at a pulse rate of 1/s for impulse noise with a uniform spectrum across the bandwidth of the receiver.

8.2.4 Average Envelope-Voltage Detector

The detector should provide an average measurement for all types of modulation envelopes and statistically random signals. The linear dynamic range, as measured between the receiver noise floor and the 1 dB gain compression point, should equal or exceed 70 dB. This ensures an error of measurement of less than 1 dB for impulsive noise signals. A selectable integration time constant ranging from 0.1 s to 100 s is recommended.

8.3 Detector Accuracy

The amplitude accuracy shall be ± 2 dB.

8.4 Associated Output Devices

Each detector shall be fitted with an output indicator which provides a continuous, real-time indication of the measured parameter. The indicator may be a panel meter, a digital display, a crt, or an oscillograph.

8.4.1 RMS-Voltage Detector Output

Two output indicators shall be provided for simultaneous indication of rms voltage and voltage deviation V_d . The rms indicator shall have a logarithmic scale with a minimum range of 40 dB. The V_d indicator shall have a logarithmic scale with a minimum range of 0 to 40 dB.

8.4.2 Quasi-Peak Voltage Detector Output

The indicator scale shall have a minimum linear deflection range of 4 to 1. In addition, a logarithmic scale is recommended.

The indicator shall be critically damped with time constants of 160 ms for the 0.01 to 30 MHz range and 100 ms for the 30 MHz—1000 MHz range. The mechanical timeconstant assumes that the mechanical deflection of the indicator is linear with the input current. The use of an indicator having a different relationship between input current and deflection is not precluded.

The time constant of the indicator can also be defined as being equal to the duration of a rectangular pulse of constant amplitude which produces a deflection equal to 35% of the steady deflection produced by a direct current having the same amplitude as that of the rectangular pulse.

8.4.3 Peak-Voltage Detector Output

The output indicator for the peak-voltage detector shall have a range of 0 to 100 and a logarithmic scale with a minimum range of 0 to 40 dB.

8.4.4 Average-Voltage Detector Output

The indicator scale may be either linear with a range of 0 to 100 or a logarithmic function of the impressed voltage with a 0 to 40 dB minimum range.

8.4.5 V_d Output

The indicator scale may be linear with a range of 0 to 100 or a logarithmic function of impressed voltage with a 0 to 40 dB minimum range.

8.5 Comparison of Detector Functions

Table 8 has been included to provide a direct comparison among the performance of the four types of detectors in typical electromagnetic signal environments. The responses of the four detector functions to several types of signals are shown and certain differences in response [27], [29], and [37].

8.6 Amplitude Probability Distribution (APD), and ACR, PSD, and PDD

A frequently used amplitude distribution measure of a random signal is the amplitude probability distribution (APD). Equipment is now available to make APD measurements of the radio noise process. This equipment functions at baseband, thus requiring the detected envelope to be measured by a receiver with constant gain. The instruments compute the desired statistical function and provide either an oscilloscope or XY plotter display. The receiver and statistical measuring device are calibrated as a unit by inserting a range of continuous wave signal amplitudes and fixing a set of threshold levels of the statistical function.

The remaining statistical measures of an observed signal shall be obtained from sampling and reducing the recorded data.

Table 8— Comparison of Detector Functions

Waveform	RMS	Average	Peak	Quasi-peak	Differences (dB)		
	Responding Meter Indicates	Responding Meter I ndicates	Responding Meter Indicates	Responding Meter Indicates	Average RMS	Peak RMS	Quasi-Peak RMS
Sine Wave	0.707	0.707	0.707	0.707	0.0	0.0	0.0
Gaussian Noise	1σ	0.887σ	NOTE (1)	1.83σ	-1.04	—	5.25
Pulse Train $\alpha = 0$ $d_\alpha = 0.01$	0.316	0.1	0.707	—	-10.0	6.99	—
Pulse Train $\alpha = 0$ $d_\alpha = 0.01$	0.10	0.01	0.707	—	-20.0	16.99	—
Recurrent NOTE (2) Impulses with $f_p = 100$	1.0	0.10	13.5	6.08	-20.0	22.3	15.7
Recurrent NOTE (2) Impulses with $f_p = 1000$	1.0	0.316	4.27	3.62	-10.0	12.3	11.2

NOTES:

- 1 — A peak reading has limited meaning for random noise unless a sufficient observation time is allowed to assure that the maximum likely impulse has been sensed.
- 2 — For these two examples, we have set B (radio noise bandwidth) = 10 kHz, Δf_{imp} (impulse bandwidth) = $1.35 \cdot 10$ kHz, Δf_{6dB} (6 dB bandwidth) = $1.07 \cdot 10$ kHz, $R_d/R_c = 600f_p =$ impulse repetition rate $p(\alpha) = 0.45$ for $f_p = 100$, $p(\alpha) = 0.85$ for $f_p = 1000$ [27].

9. Data Handling

9.1 Data Recording

Consistency and uniformity are essential to all data reporting. The recommended procedure should include a permanent record of all relevant experimental parameters and notes on any special test conditions which existed at the time of investigation. It is also recommended that the following information be included in a data report as a minimum:

9.1.1 Minimum Information for Data Report

- 1) Reduced measurement data. For spectrum surveys, plots, or tabulations of field strength versus frequency.
- 2) For interior surveys, structural descriptions including building materials; dimensions of floors, walls, and ceilings; window dimensions and locations; type of insulation; lighting fixtures; electrical raceways; air ducts; number and elevation of floors; and photographs.
- 3) For exterior surveys, a description of the terrain, soil, ground cover, site elevation, location coordinates, and position of scattering objects (trees, buildings, power facilities, etc).
- 4) Date, time, and location of measurements.
- 5) Conditions that may influence measured data (weather, atmospheric conditions, etc).
- 6) Lists of instrumentation, antennas, and antenna factors.
- 7) A list of personnel performing the work.
- 8) Conditions generally regarded as special test conditions (proximity of antennas to absorbing, scattering, or reradiating structures located above, on, or beneath the surface; extreme weather conditions, and unusual or uncontrollable human movement in the survey area).

9.1.2 Methods for Data Recording

The methods used for data recording can be divided into five classes as follows:

- 1) *Manual*. The outputs of the measuring equipment are read by an operator and recorded manually on data sheets.
- 2) *Analog*. The output of the measuring equipment drives some form of analog recorder, such as a strip chart, recorder, an *XY* recorder, or a camera-equipped oscilloscope.
- 3) *Digital*. The outputs of the measuring equipment are digitized and stored on tapes or other storage media.
- 4) *Fully Automated*. The measuring equipment is controlled by a computer. The output of the measuring equipment may be digitized for storage, for display, or both.
- 5) *Hybrid*. Use is made of both analog and digital recording equipment.

9.1.3 Additional Information Required

The complexity of the available data recording systems, in general, follows the order given in 9.1.2. The one requirement for any measurement procedure is that all data shall be permanently recorded or stored at the time the measurements are made. In addition, the following information shall be noted:

- 1) Antenna used (its height, bearing information, antenna factor, gain, type, and frequency range)
- 2) Cable loss between the antenna and associated equipment, unless it is included in the antenna factor
- 3) All gains or losses of receiving system components—for example, amplifiers, attenuators, power splitters, filters, etc
- 4) Any internal attenuator setting
- 5) Frequency or frequencies being measured
- 6) Bandwidth used for the study
- 7) Detector functions selected and characteristics—for example, time constants
- 8) Post detector filter characteristics such as bandwidth

- 9) Type of output—for example, log, linear, and characteristics (for example, range)
- 10) Signal and noise levels measured
- 11) Time

For most measurements, several of the aforementioned items may be fixed for one set of studies. It is necessary to record the variable items only.

The form and method of recording data will depend upon the equipment used. If mobile equipment is employed, sophisticated recording systems can be used that will automatically record the data in a form ready for computer processing at a central facility. A small on-board computer that has been checked for spurious emissions can be used to provide real time results. Since the data will be included in the data bank, recordings should be made in a manner compatible with machine handling of computer input. The most desirable system is magnetic tape recordings. Punched tape or cards are less desirable alternatives. A printer-type recorder or strip chart recorder will provide a permanent record which is desirable, but if any volume of data is involved, the time required for hand-scaling and converting to a machine-compatible form is more expensive than recording in a compatible form initially. It is imperative that all relevant information that would affect interpretation of the data be supplied either in the recordings or on calibration sheets, log sheets, etc.

9.1.4 Manual System

For a manual system, Fig 16 illustrates a typical data sheet that may be used. The *comments* column indicates the type of detector employed and cites specific information that will be needed later to interpret the location features.

9.1.5 Analog System

Figure 17 is a master data sheet applicable to an analog data recording system such as a field intensity meter. The *X* axis has not been labeled. Either time or frequency may be placed on the abscissa. For time calibration, a square wave generator may be used on the *Y* axis. The amplitude of the ramp generator or the gain of the *X*-axis amplifier is adjusted for the time scale desired. Typically, the frequency of the square wave calibration generator will lie between 0.01 Hz and 1 Hz. When the abscissa is provided with a frequency scale, the gain of the *X*-axis amplifier is adjusted to provide a full range sweep. A crystal controlled oscillator with an output rich in harmonics is then used to provide a set of frequency marks along the *X* axis.

Figure 18 is a copy of a data sheet that may be used with a spectrum analyzer and is similar to Fig 17, while Fig 19 is a data sheet used for mounting photographs and provides supplementary data entry spaces for information essential in the reduction of the results.

Analog data presentations should include, in addition to the data trace, a measure of the receiving system noise threshold or noise floor.

Manually recorded measurements of random noise processes are facilitated by the use of a data recording sheet as shown in Fig 20. Spaces are provided for instrument characteristics and notes concerning overt features of the noise. Eleven readings of the two meters V_{rms} and V_d are taken at 15 s intervals and recorded. The median value is then formed for the frequency of interest. If the readings are nearly constant for 3 min, it should be indicated. In this manner a 15 s sampling of a running average may be achieved. All 15 s readings are then available for later combining by location and time of day to obtain a distribution of the 15 s readings.

Generally, some form of analysis will be performed in the field, either to obtain an approximate answer to a specific question or to ensure that the correct and desired data are being obtained. This may take the form of on-board computer analysis, a print-out of the tape recorded data, or the tabulation of the median values. The long-range objectives however require that an analysis of the data base be performed to provide the best estimates of expected radiation. In any field analysis of the data, care shall be taken to preserve the original information in a useful form.

PLACE _____
DATE _____
TIME _____

B/W _____
DETECTOR FUNCTION _____

SWEEP TIME _____
VERNIER _____
RANGE _____

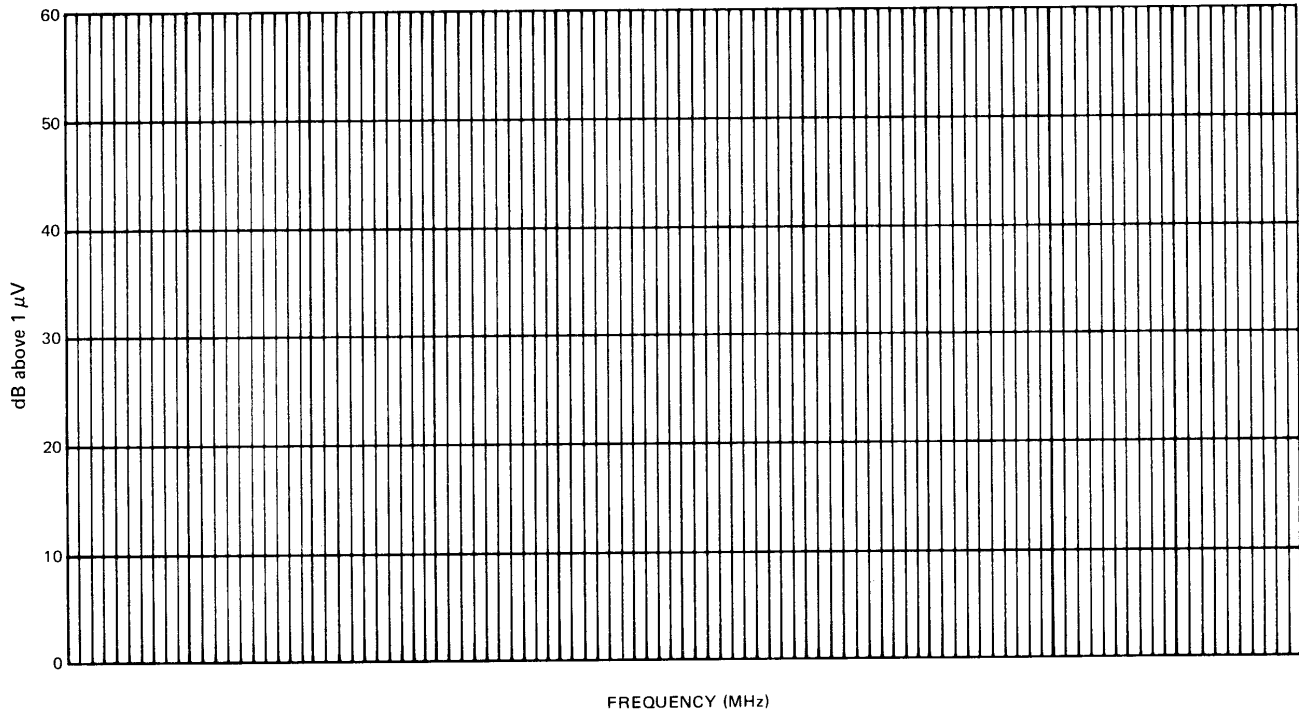
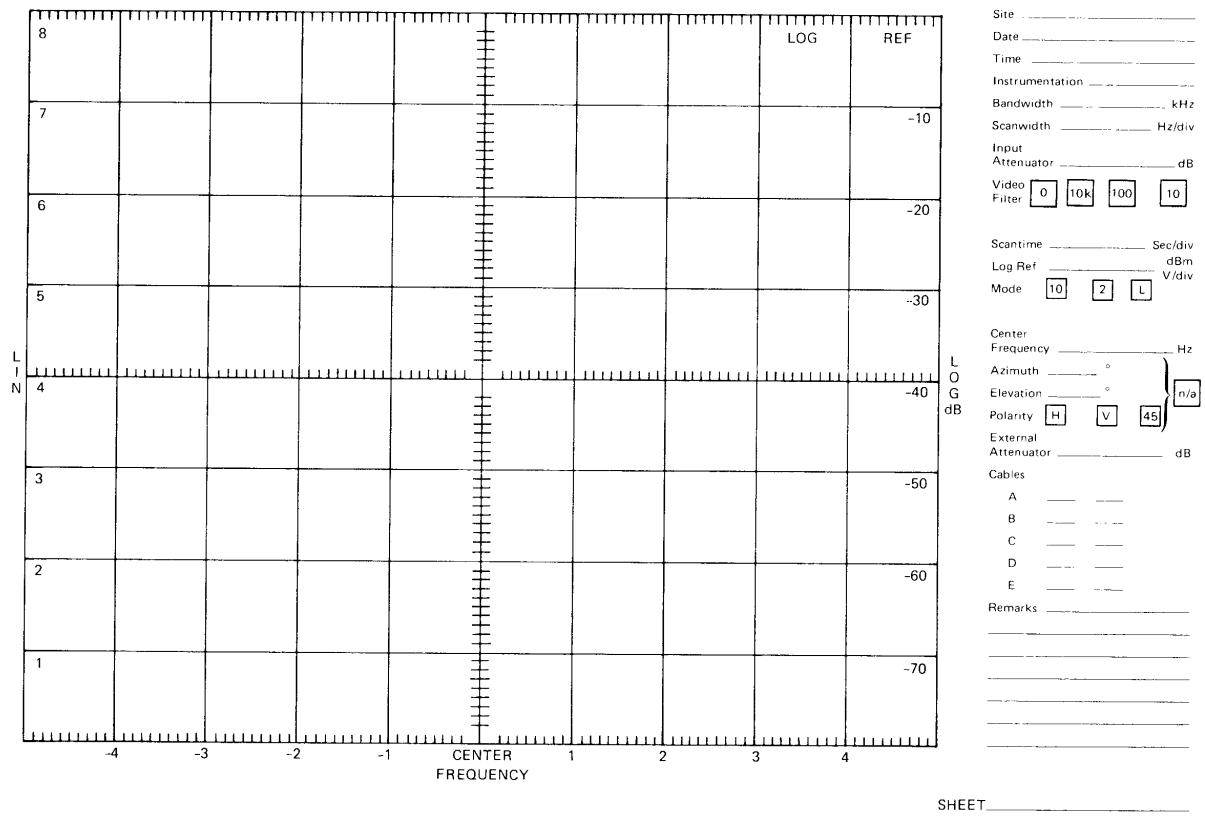

Figure 17— XY Plot Sheet



SHEET _____

Figure 18— Spectrum Analyzer XY Plot Sheet

SITE _____

Time _____ Instrumentation _____

Bandwidth _____ kHz Scanwidth _____ Hz/div

Input Attenuator _____ dB Video Filter 0 10k 100 10

Scantime _____ Sec/div Log Ref _____ dBm V/div

Mode 10 2 L

Center Frequency _____ Hz A _____

Azimuth _____ ° B _____

Elevation _____ ° n/a CABLES C _____

Polarity H V 45 D _____

E _____

External Attenuator _____ dB

Remarks _____

DATE _____

Time _____ Instrumentation _____

Bandwidth _____ kHz Scanwidth _____ Hz/div

Input Attenuator _____ dB Video Filter 0 10k 100 10

Scantime _____ Sec/div Log Ref _____ dBm V/div

Mode 10 2 L

Center Frequency _____ Hz A _____

Azimuth _____ ° B _____

Elevation _____ ° n/a CABLES C _____

Polarity H V 45 D _____

E _____

External Attenuator _____ dB

Remarks _____

SHEET _____

Figure 19— Spectrum Analyzer EMC Photo Data Sheet

9.2 Data Processing

The objective of the second step in data handling procedures (data processing), is to extract information from the accumulation of measured results which quantitatively characterizes the survey area. Data processing may include extraction of average values of signal strength, the upper- and lower-decile values D_u and D_l , the frequencies and modulation characteristics of the observed signals, or the statistical moments and density functions of the random signals present.

From statistical data, it is possible to compute various envelope voltages. Given the APD data, for example, it is possible to calculate V_{rms} , V_{av} , V_d , and V_{peak} , which are functions of the envelope amplitudes. The algorithms for the first three are as follows:

$$V_{\text{av}} = - \sum_{i=1}^{N_t-1} V_i \Delta p_o(v_i), \quad \text{V} \quad (\text{Eq19})$$

$$(V_{\text{rms}})^2 = - \sum_{i=1}^{N_t-1} V_i \Delta p_o(v_i), \quad \text{V}^2 \quad (\text{Eq20})$$

where

$$\begin{aligned} V_i &= v_i + \Delta_v/2 \\ v_i &= i \text{ measured level threshold voltage (volts) and } v_{i+1} > v_i \\ \Delta_v &= (v_2 - v_1) \text{ (assuming the } v_i \text{ are all equidistant)} \\ \Delta p_o(v_i) &= p_o(v_{i+1}) - p_o(v_i) \\ P_o(v_i) &= \text{measured probability that the } i \text{ threshold value is exceeded} \\ N_t &= \text{total number of threshold levels for which one has } p_o(v_i) \text{ data} \end{aligned}$$

$$V_d = 20 \log_{10} V_{\text{rms}} - 20 \log_{10} V_{\text{av}}, \quad \text{dB} \quad (\text{Eq21})$$

To estimate a value of V_{peak} , some probability threshold shall be set, for example, V_{peak} is the level that is exceeded 0.0001% of the time. For a V_{peak} measurement one shall also state the duration of the observation time during which the peak value was observed, since—theoretically—there is no peak value of a random noise process, that is, there is always some finite probability that any level will be exceeded.

9.3 Examples of Data Usage

Typically a site survey may provide information that can be used to study the performance of a communication system operating in the radio environment. The following three examples show how data collected may be used for

- 1) Site evaluation
- 2) System design
- 3) System performance prediction

9.3.1 Site Evaluation

Audio and visual monitoring of electromagnetic fields at a test location may reveal that the dominant signals arise from either natural or man-made unintentional noise. The observed values of F_a and its median, F_{am} , may be compared with

data of Figs 2 to 4 to determine the feasibility of the interpretation. Using the gain of the test antenna and Eq 3, the effective aperture area A , may be computed in square meters and used with Fig 5 to compare the measured site noise levels with the expected noise power of galactic sources. Data selected for the test location and date [14], are then compared with the observed values of F_a and F_{am} (for frequencies below 30 MHz) to determine whether the level of atmospheric noise is significant.

9.3.2 System Design

The receiving system operating noise factor f , which takes into account both external noise and internal system noise, is a way of assessing the performance of a complete receiving system. If one assumes that the receiver is free from spurious responses and all the components are at the same temperature (that is, no super-cooled components) then f is given by

$$f = f_a - 1 + \Sigma l_c l_t f_r \quad (\text{Eq22})$$

f may be expressed in decibels using

$$F = 10 \log_{10} f \quad (\text{Eq23})$$

where

$$\begin{aligned} l_c &= \text{loss of the antenna circuit} \\ l_t &= \text{loss of the transmission line} \\ f_r &= \text{noise factor of the receiver} \end{aligned}$$

If one assumes no antenna or transmission line losses, then the above equation for f becomes

$$f = f_a - 1 + f_r \quad (\text{Eq24})$$

If the measured minimum external noise figure $F_a = 20$ dB above kTB (that is, $f_a = 100$) for the system bandwidth considered, the operating system noise figure for a perfect receiver is $F = 20$ dB. Let the criterion for f_r be that its value is such that it will only increase F by 1 dB. Thus, $f_r = 26.9$ ($F_r = 14.3$ dB) for a system operating noise factor of 21 dB ($f = 126$). Any lower receiver noise figure cannot decrease F by more than 1 dB, for example, a practical system in which the receiver noise figure is 8 dB will be external noise limited, that is, better than necessary.

If the antenna losses and the transmission losses were 3 dB each, the receiving system operating noise factor equation becomes

$$f = f_a - 1 + 4f_r \quad (\text{Eq25})$$

In this case, for F not to be raised by more than 1 dB (to 21 dB) F_r shall not be higher than 8.3 dB ($f_r = 6.8$). Any higher receiver noise figure will result in a system that is not external noise limited.

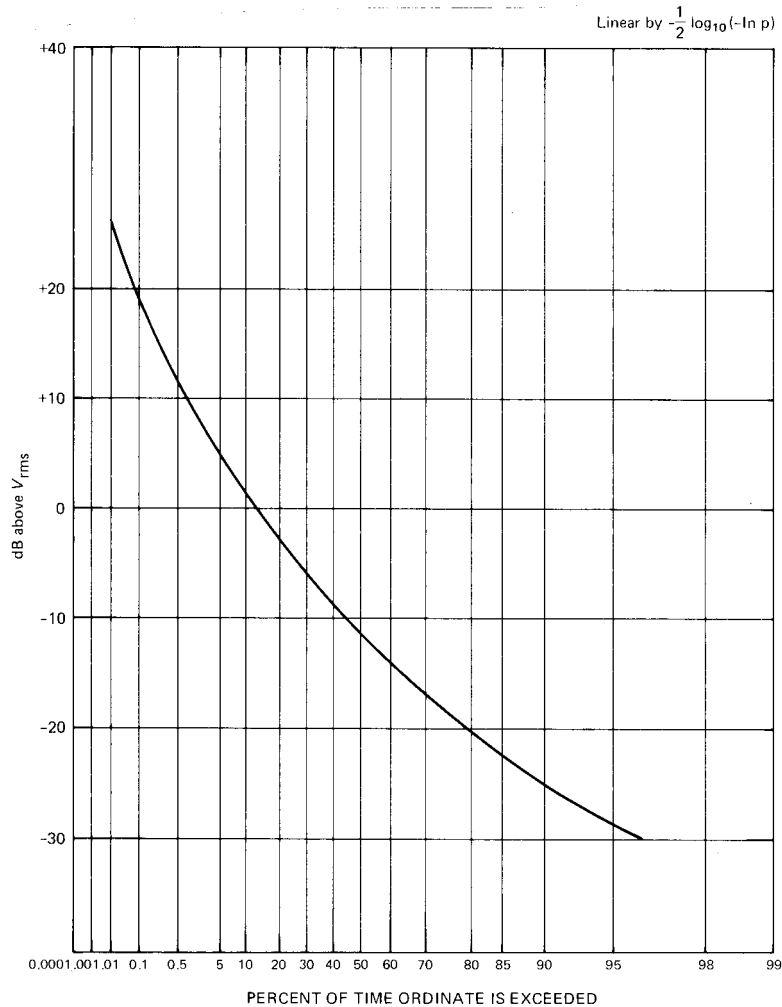

Figure 21— APD of a Man-Made Radio-Noise Process

9.3.3 Performance Prediction

The final example shows how statistical APD data may be used to predict the performance of a noncoherent frequency shift keying (NCFSK) system. In this case, one assumes that the relative APD Fig 19 of the radio environment has been measured in the communication system bandwidth. In Fig 21, the percentage of time that each ordinate level is exceeded is plotted. Note that the rms level is exceeded 13% of the time. For NCFSK signal modulation the probability of a bit error is given by one half the probability that the instantaneous noise envelope exceeds the signal level. If the signal-to-noise ratio (snr) is equal to 18 dB, the signal is exceeded 0.15% of the time. Therefore, the probability of a bit error is $7.5 \cdot 10^{-4}$. Similarly, other error rates may be read from the graph for various signal-to-noise ratios.

10. Exterior Test Measurement Platforms

10.1 Ground Based Measurements

For ground-based measurements, the measurement vehicle may range from a small automobile with a removable tripod antenna and test equipment cabinet to a completely outfitted self-contained van. To have an all-weather measurement system, vehicular containment is desirable. Direct-power measurements using a receiver and preamplifier may be accomplished in almost any vehicle. However, statistically accurate measurements usually require a more elaborate accommodation. For these, rack mounting of instrumentation and careful execution of inter-cabling is necessary. Care should be taken in arranging instrumentation for single-person operation. A fixed working and writing surface, properly illuminated for nighttime activity, is desirable. A single ground point for all electrical equipment should be assured. Heavy copper cabling and strong grounding stakes of at least 3 ft lengths should be available for use in exterior survey areas where low-level electromagnetic fields are expected.

Storage batteries or an auxiliary motor generator will be required in remote areas. Rarely is it possible or desirable to provide primary power for the instrumentation from the vehicle battery or battery charging system. When the test plans call for stationary measurements to be made in remote areas, the auxiliary motor generator should be supplied with at least 100 m of power leads and have its output power circuit filtered and regulated. Shorter leads may be used if the generator has been very well shielded or its ignition system radiation suppressed.

Provision should be made for assuring a good earth ground to the motor generator by means of a large conductor copper cable connected to sturdy 3 ft (or longer) ground stakes. Any auxiliary space heaters employed in the enclosed cab for operator comfort should be checked for the presence of radio-band emissions—specifically from relays—silicon-controlled rectifiers, and switches. When using a vehicle, the antenna should not be mounted on the ground or on a tripod near the vehicle because of possible distortion of the antenna pattern. Rather, it should be mounted in the center of the vehicle roof or removed at least 100 ft from the vehicle. Some antennas, for example, the discone or a vertical dipole, may have to be mounted on a mast at the rear of the vehicle. Although the effects of most vehicles on measurements with mobile antennas has been found to be negligible, the vehicle and antenna combination should be calibrated to confirm the antenna factors and to check for the existence of azimuthal asymmetries in the antenna pattern, as described in Section 5.

If for any reason there is a need for the vehicle engine to run, then the effects of the ignition noise on the measurements should be known. To determine those effects, measurements at a quiet location should be made with the engine alternatively on and off.

If the measuring equipment is to be operated with a gasoline generator, a test similar to the aforementioned shall be conducted to determine the effect of the generator noise. In performing this test the equipment shall be operated on batteries for the engine-off condition.

NOTE — Most small generators of 0.3 kW to 1 kW capacity capable of supplying a measurement system without a computer have been found to be electrically quiet. However, it may be necessary to shield the generator or operate it at a separate location.

If the test plan requires the acquisition of data while the vehicle platform is moving and if a comparison of the data acquired—with the vehicle running and with the engine off—identifies the ignition system to be a source of an unacceptably high radiation level, it will become necessary to take special measures to quiet the vehicle. Replacement of points, spark plugs (in a gasoline engine), and primary and secondary ignition cables should be considered. Use of resistor spark plugs and high-temperature, high-resistance wires to the distributor and coil may be required [47]. Special underhood shielding in the vicinity of the distributor and an electronic ignition module may have to be added. The radiation emitted by the vehicle gauges and the battery charging system should be checked by either probing its vicinity with a small pickup coil or dipole after the ignition system has been quieted, or by briefly disconnecting the drive belt and running the engine to detect any emission level decrease.

10.2 Marine Measurements

Shipborne measurements should follow the procedures outlined for ground based studies with modifications performed in the electrical grounding procedures to be compatible with the test area environment. Special care is required in selecting instrumentation system ground points. Make certain that the contact point is corrosion-free and that metal joints, contact points, and various items of hardware in the near field of the antennas are not sources of radio-frequency interference as a result of intermodulation products, gap discharge, or corona-generated noise.

10.3 Airborne Measurements

Instrumentation mounting and grounding on aircraft platforms entail unique problems. Very secure equipment rack arrangements and instrument cabling are required. A single-point electrical ground shall be ensured for all test instrumentation. Battery operation of all test equipment is desirable, and often necessary because of the limited auxiliary power generation capacity of smaller aircraft.

Special attention shall be given to ensuring that the aircraft ignition system is not a source of interference. Air-certified electrical system procedures shall be employed in affecting any changes in the aircraft ignition or electrical system.

Airborne antenna calibration presents a unique problem. The difficulty encountered in attempting antenna calibration after aircraft installation is appreciable. Approximate patterns and antenna factors may be obtained if test areas are available on accessible airports. Fly-over calibrations of patterns and gain are difficult to execute and are not recommended unless special facilities are available [38]. The preferred procedure is to perform antenna pattern and gain measurements on an antenna pattern range using the specified antenna and a mockup ground plane built to full scale but representative of that portion of the airframe within 10 ft or 5 wavelengths of the lowest intended frequency for the survey. The simulated airframe ground plane possessing a reasonable facsimile of the actual surface contours may be constructed using inexpensive materials overlaid with high conductivity foil such as aluminum. Subsequently, the transmission line losses between the antenna and the receiver shall be measured as a function of frequency.

Annex A Derivation of the External Noise Figure F_a , for Several Antennas

(Informative)

(These Appendixes are not a part of IEEE Std 473-1985, IEEE Recommended Practice for an Electromagnetic Site Survey (10 kHz to 10 GHz).)

A.1

The derivation of the external noise figure F_a , in terms of the electric field strength, tuned frequency, and receiver bandwidth for a short monopole, tuned dipole, or any matched antenna for which the antenna factor AF , may be obtained is as follows:

The noise power received by an antenna may be expressed in terms of an effective external noise factor f_a defined by

$$f_a = \frac{P_n}{kT_oB} \quad (\text{Eq A1})$$

where

- P_n = mean noise power available from an equivalent loss-free antenna, W
- k = Boltzmann's constant ($1.38 \cdot 10^{-23}$ J/K)
- T_o = reference temperature, K
- B = receiver noise bandwidth, Hz

From Eq 1 f_a is a dimensionless factor, thus one may define the quantity

$$F_a = 10 \log_{10} f_a, \quad \text{dB} \quad (\text{Eq A2})$$

which is the noise power per unit bandwidth in decibels relative to kT .

NOTE — f_a may also be expressed as a temperature T_a

$$f_a = \frac{T_a}{T_o} \quad (\text{Eq A3})$$

where

- T_a = antenna temperature

Taking 10 times log of Eq 1, one obtains

$$F_a = P_n - 10 \log_{10} kT_o - 10 \log_{10} B \quad (\text{Eq A4})$$

Here F_a is in decibels and, accordingly, each term of the right-hand side of Eq 4 may be considered to have units of decibels and P_n is the mean noise power (decibels above one watt).

If $T = 288$ K (approximately 15 °C)

$$10 \log_{10} kT = -204 \text{ dB} \quad (\text{Eq A5})$$

NOTE — For a temperature change of ± 30 °C, the reference changes by only ± 0.4 dB.

Substituting Eq 5 into Eq 4 yields

$$F_a = P_n + 204 - 10 \log_{10} B \quad (\text{Eq A6})$$

From antenna theory [B5]¹¹ the total power in watts extracted from a radio wave by a loss-less antenna and delivered to a receiver (assuming a perfect impedance match) is given by

$$p_n = \frac{E_n^2 h_e^2}{4r_a}, \quad \text{W} \quad (\text{Eq A7})$$

where

E_n = incident rms noise field strength, V/m

h_e = effective antenna height, m

r_a = radiation resistance, Ω

The charge distribution is essentially constant for a *short* antenna; thus, the current distribution is linear [B3]. Also the effective height for a straight vertical antenna (less than $\lambda/4$ in length) over a perfect ground is given by [B2]

$$h_e = \frac{\lambda}{\pi \sin(2\pi \hat{h}/\lambda)} \sin^2(\pi \hat{h}/\lambda) \quad (\text{Eq A8})$$

for \hat{h} (antenna length) $\leq \lambda/4$

$$\text{If } \hat{h} = \lambda/4, h_e = 0.637\hat{h}$$

$$\hat{h} = \lambda/8, h_e = 0.528\hat{h}$$

$$\hat{h} = \lambda/10, h_e = 0.517\hat{h}$$

Therefore, for a *short* antenna,

$$h_e \approx \hat{h} / 2 \text{ m}$$

The radiation resistance r_a , for an antenna with a linear current distribution over a perfect ground and $h_e = \hat{h} / 2$, is given by [B4] as

$$r_a = \frac{40\pi^2 \hat{h}^2}{\lambda^2}, \quad \Omega \quad (\text{Eq A9})$$

¹¹The numbers in brackets preceded by letter B correspond to those of the Bibliography, Appendix .

Substituting Eq 9 into Eq 7 and replacing λ by $300/F_M$, where F_M is the received frequency in MHz, yields

$$p_n = \frac{E_n^2 \hat{h}^2}{16} \cdot \frac{300^2}{F_M^2} \cdot \frac{1}{40\pi^2 \hat{h}^2} \quad (\text{Eq A10})$$

or

$$p_n = \frac{14.3E_n^2}{F_M^2}$$

Transforming into decibel results in

$$P_n = E_{n(\text{dB})} - 20 \log_{10} F_M + 11.5 \quad (\text{Eq A11})$$

Substituting Eq 11 into Eq 6 and referring E_n to $1 \mu\text{V/m}$ yields

$$F_a = E_{n(\text{dB})} - 120 - 20 \log_{10} F_M + 11.5 + 204 - 10 \log_{10} B$$

or

$$F_a = E_{n(\text{dB})} - 20 \log_{10} F_M + 95.5 - 10 \log_{10} B \quad (\text{Eq A12})$$

for a short antenna over a perfectly conducting ground plane

where

$$F_a = \text{external noise figure, dB}$$

$$F_M = \text{received frequency, MHz}$$

A similar expression may be derived for a halfwave dipole in free space

$$F_a = E_{n(\text{dB})} - 20 \log_{10} F_M + 98.6 - 10 \log_{10} B \quad (\text{Eq A13})$$

For other types of antennas, corresponding expressions may be derived. To relate F_a to the antenna factor we proceed as follows:

The power intercepted by a receiving antenna is the product of the power density and the receiving area, that is:

$$p_n = \frac{E_n^2}{120\pi} \cdot \frac{g\lambda^2}{4\pi} \quad (\text{Eq A14})$$

where

$$g = \text{antenna gain}$$

$$\lambda = \text{received wavelength, m}$$

Transforming Eq 14 into dB, substituting $\lambda = 300/F_M$, and using $G = 10 \log_{10} g$ yields

$$P_n = E_{n(\text{dB})} - 120 - 20 \log_{10} F_M + G + 10 \log_{10} \frac{9 \cdot (10)^4}{480\pi^2} \quad (\text{Eq A15})$$

The antenna output voltage may be related to the incident field strength by defining the effective height of the antenna (H_e in decibels above 1 m).

$$E_{n(\text{dB})} = V_{\text{rms}} - H_e + 6 + L_c \quad (\text{Eq A16})$$

where

$$L_c = \text{antenna cable loss, (dB)}$$

Substituting Eqs 15 and 16 into Eq 6:

$$F_a = m V_{\text{rms}} - H_e + 6 + L_c - 120 - 20 \log_{10} F_M + G + 12.8 + 204 + 10 \log_{10} B$$

or

$$F_a = \mu V_{\text{rms}} - 20 \log_{10} F_M - 10 \log_{10} B + (G - H_e + 6) + L_c + 96.8 \quad (\text{Eq A17})$$

where

$$\mu V_{\text{rms}} = \text{measured rms envelope voltage (dB above } 1 \mu\text{V)}$$

The term $(G - H_e + 6)$ is called the antenna factor AF , and unless the antenna gain and effective height are known theoretically, the whole antenna factor term may be measured by comparing field strength measurements with a known antenna [B1]. Equation 12 may be written in a similar form

$$F_a = V_{\text{rms}} - 20 \log_{10} F_M + 95.5 - 10 \log_{10} B + (CF - H_e) + L_c \quad (\text{Eq A18})$$

where

$$CF = \text{coupler figure if a standard antenna is used}$$

NOTE — Equations 12 or 18 are only good for a short vertical antenna where H_e is defined as $10 \log_{10} (DCL108/2)$ where $DCL108$ is the physical length of the antenna.

A.2

The operating noise factor f , for a receiving system shown in Fig — may be mathematically represented as

$$f = f_a + (l_c - 1) \frac{T_c}{T_o} + (l_t - 1) l_c \frac{T_t}{T_o} + (f_r - 1) l_c l_t \quad (\text{Eq A19})$$

where

- f_a = external noise factor
 l_c = antenna circuit loss factor defined as the ratio of input to available output power of the circuit
 T_c = temperature of the antenna circuit, Kelvin (K)
 l_t = transmission line loss defined as the ratio of input to available output power of the transmission line
 T_o = reference temperature, Kelvin
 T_t = actual temperature of the transmission line, Kelvin
 f_r = receiver noise factor

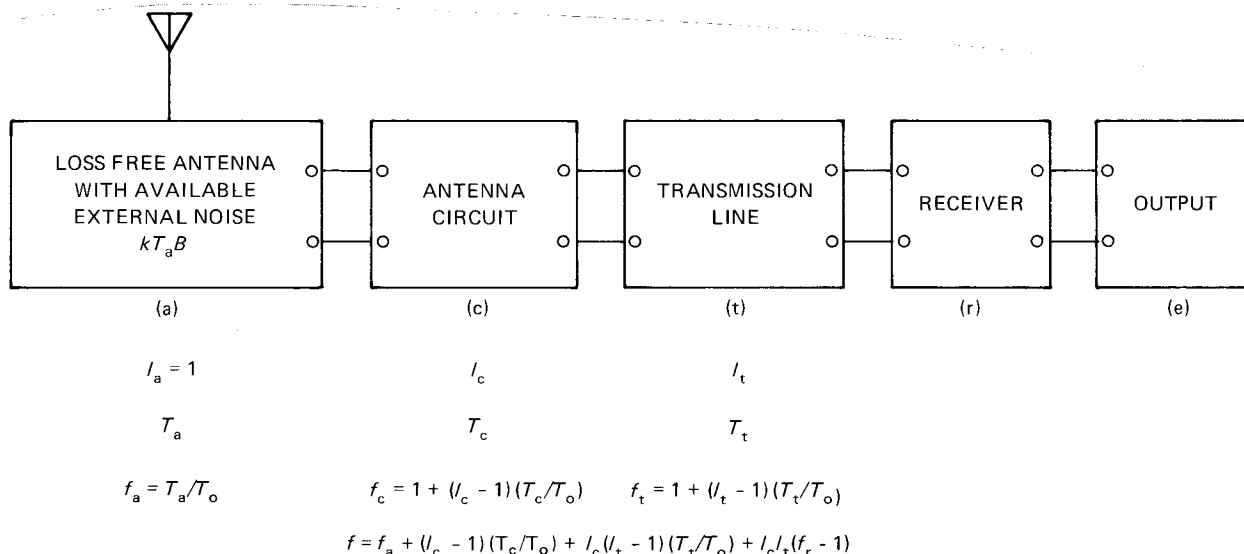

Figure A.1—The Receiving System and Its Operating Noise Factor f

If the antenna circuit temperature T_c , and the transmission line temperature T_t , are equal to the reference temperature T_o , then f can be written in terms of the noise factors as

$$f = f_a - 1 + l_c l_t f_r (T_c = T_t = T_o) \quad (\text{Eq A20})$$

A.3

The limiting value of attenuation l , that may be inserted before a receiver having an effective noise temperature T_e , can be related to the allowable increase in receiving system noise temperature ηT_{sys} , ($\eta > 0$) by expressing the noise power at the antenna terminals in terms of the unit noise power contributions per hertz as

$$k[T_a + T_o(l_c l_t - 1) + T_e(l_c l_t)] \quad (\text{Eq A21})$$

and by equating the above relation to the enhanced system noise power expression given by

$$k(1 + \eta)[T_a + T_o(l_c l_t - 1) + T_e l_c l_t] \quad (\text{Eq A22})$$

Solving for l from the equation thus formed yields, after simplification,

$$l = 1 + \eta \left[1 - \frac{T_o - T_a}{(T_o + T_e) l_c l_t} \right] \quad (\text{Eq A23})$$

Annex B Bibliography

[B1] IEEE Std 302-1969 (1981), IEEE Standard Methods for Measuring Electromagnetic Field Strength for Frequencies Below 1000 MHz in Radio Wave Propagation.

[B2] Reference Data for Radio Engineers. New York: Howard W. Sams Company, 1975.

[B3] SCHELKUNOFF, S. A. Electromagnetic Fields. New York: Blaisdell Publishing Company, 1963.

[B4] SCHELKUNOFF, S. A. and FRIIS, H. T. *Antenna Theory and Practice*. New York: John Wiley and Sons, 1952, p 309.

[B5] TERMAN, F. E. *Radio Engineers Handbook*. New York: McGraw-Hill, 1943.