

1 **IEEE P1629™/D6.3**  
2 **Draft Standard for Performance of dc**  
3 **Overhead Current Collectors for Rail**  
4 **Transit Vehicles**

5 Sponsor

6 **Current Collect Working Group of the Overhead Contact Systems Sub-committee**  
7 **of the Rail Transit Interface Standards Committee**  
8 of the  
9 **IEEE Vehicular Technology Society**

10 Approved <XX Month 20XX>

11 **IEEE-SA Standards Board**

12

13

14 Copyright 2009 by the Institute of Electrical and Electronics Engineers, Inc.

15 Three Park Avenue

16 New York, New York 10016-5997, USA

17 All rights reserved.

18 This document is an unapproved draft of a proposed IEEE Standard. As such, this document is subject to  
19 change. **USE AT YOUR OWN RISK!** Because this is an unapproved draft, this document must not be  
20 utilized for any conformance/compliance purposes. Permission is hereby granted for IEEE Standards  
21 Committee participants to reproduce this document for purposes of international standardization  
22 consideration. Prior to adoption of this document, in whole or in part, by another standards development  
23 organization, permission must first be obtained from the IEEE Standards Activities Department  
24 (stds.ipr@ieee.org). Other entities seeking permission to reproduce this document, in whole or in part, must  
25 also obtain permission from the IEEE Standards Activities Department.

26 IEEE Standards Activities Department

27 445 Hoes Lane

28 Piscataway, NJ 08854, USA

29

1 **Abstract:** This standard defines the general characteristics of pantographs that enable current  
2 collection from an overhead contact system on light rail transit and heavy rail transit systems. The  
3 standard contains definitions pertinent to pantographs, including general definitions, specific  
4 pantograph terminology, and pantograph components, pantograph dimensions, and operating  
5 characteristics.

6 The operating requirements that need to be defined by the purchaser of pantographs are stated.  
7 In addition, standard dimensions for the collector head and contact strip, various pantograph  
8 mechanical and operational requirements, environmental conditions, and maintainability and  
9 documentation requirements are specified. The standard also includes various testing  
10 methodologies and requirements

11  
12 **Keywords:** pantograph, contact strip, collector head, overhead contact system, gradient,  
13 tracking, traction, rail vehicle, light rail, heavy rail, streetcar, tramcar, transit, railway.  
14

15

---

The Institute of Electrical and Electronics Engineers, Inc.  
3 Park Avenue, New York, NY 10016-5997, USA  
Copyright © 20XX by the Institute of Electrical and Electronics Engineers, Inc.  
All rights reserved. Published <XX Month 20XX>. Printed in the United States of America.

IEEE is a registered trademark in the U.S. Patent & Trademark Office, owned by the Institute of Electrical and Electronics Engineers, Incorporated.

PDF: ISBN 978-0-XXXX-XXXX-X STDXXXXX  
Print: ISBN 978-0-XXXX-XXXX-X STDPDXXXXX

*No part of this publication may be reproduced in any form, in an electronic retrieval system or otherwise, without the prior written permission of the publisher.*

1 **IEEE Standards** documents are developed within the IEEE Societies and the Standards Coordinating Committees of  
 2 the IEEE Standards Association (IEEE-SA) Standards Board. The IEEE develops its standards through a consensus  
 3 development process, approved by the American National Standards Institute, which brings together volunteers  
 4 representing varied viewpoints and interests to achieve the final product. Volunteers are not necessarily members of the  
 5 Institute and serve without compensation. While the IEEE administers the process and establishes rules to promote  
 6 fairness in the consensus development process, the IEEE does not independently evaluate, test, or verify the accuracy  
 7 of any of the information or the soundness of any judgments contained in its standards.

8 Use of an IEEE Standard is wholly voluntary. The IEEE disclaims liability for any personal injury, property or other  
 9 damage, of any nature whatsoever, whether special, indirect, consequential, or compensatory, directly or indirectly  
 10 resulting from the publication, use of, or reliance upon this, or any other IEEE Standard document.

11 The IEEE does not warrant or represent the accuracy or content of the material contained herein, and expressly  
 12 disclaims any express or implied warranty, including any implied warranty of merchantability or fitness for a specific  
 13 purpose, or that the use of the material contained herein is free from patent infringement. IEEE Standards documents  
 14 are supplied “**AS IS.**”

15 The existence of an IEEE Standard does not imply that there are no other ways to produce, test, measure, purchase,  
 16 market, or provide other goods and services related to the scope of the IEEE Standard. Furthermore, the viewpoint  
 17 expressed at the time a standard is approved and issued is subject to change brought about through developments in the  
 18 state of the art and comments received from users of the standard. Every IEEE Standard is subjected to review at least  
 19 every five years for revision or reaffirmation, or every ten years for stabilization. When a document is more than five  
 20 years old and has not been reaffirmed, or more than ten years old and has not been stabilized, it is reasonable to  
 21 conclude that its contents, although still of some value, do not wholly reflect the present state of the art. Users are  
 22 cautioned to check to determine that they have the latest edition of any IEEE Standard.

23 In publishing and making this document available, the IEEE is not suggesting or rendering professional or other  
 24 services for, or on behalf of, any person or entity. Nor is the IEEE undertaking to perform any duty owed by any other  
 25 person or entity to another. Any person utilizing this, and any other IEEE Standards document, should rely upon his or  
 26 her independent judgment in the exercise of reasonable care in any given circumstances or, as appropriate, seek the  
 27 advice of a competent professional in determining the appropriateness of a given IEEE standard.

28 Interpretations: Occasionally questions may arise regarding the meaning of portions of standards as they relate to  
 29 specific applications. When the need for interpretations is brought to the attention of IEEE, the Institute will initiate  
 30 action to prepare appropriate responses. Since IEEE Standards represent a consensus of concerned interests, it is  
 31 important to ensure that any interpretation has also received the concurrence of a balance of interests. For this reason,  
 32 IEEE and the members of its societies and Standards Coordinating Committees are not able to provide an instant  
 33 response to interpretation requests except in those cases where the matter has previously received formal consideration.  
 34 A statement, written or oral, that is not processed in accordance with the IEEE-SA Standards Board Operations Manual  
 35 shall not be considered the official position of IEEE or any of its committees and shall not be considered to be, nor be  
 36 relied upon as, a formal interpretation of the IEEE. At lectures, symposia, seminars, or educational courses, an  
 37 individual presenting information on IEEE standards shall make it clear that his or her views should be considered the  
 38 personal views of that individual rather than the formal position, explanation, or interpretation of the IEEE.

39 Comments for revision of IEEE Standards are welcome from any interested party, regardless of membership affiliation  
 40 with IEEE. Suggestions for changes in documents should be in the form of a proposed change of text, together with  
 41 appropriate supporting comments. Recommendations to change the status of a stabilized standard should include a  
 42 rationale as to why a revision or withdrawal is required. Comments and recommendations on standards, and requests  
 43 for interpretations should be addressed to:

44 Secretary, IEEE-SA Standards Board  
 45 445 Hoes Lane  
 46 Piscataway, NJ 08854  
 47 USA

48 Authorization to photocopy portions of any individual standard for internal or personal use is granted by The Institute  
 49 of Electrical and Electronics Engineers, Inc., provided that the appropriate fee is paid to Copyright Clearance Center.  
 50 To arrange for payment of licensing fee, please contact Copyright Clearance Center, Customer Service, 222 Rosewood  
 51 Drive, Danvers, MA 01923 USA; +1 978 750 8400. Permission to photocopy portions of any individual standard for  
 52 educational classroom use can also be obtained through the Copyright Clearance Center.

## 1 Introduction

2 This introduction is not part of IEEE P1629/D6.3, Draft Standard for Performance of dc Overhead Current Collectors  
3 for Rail Transit Vehicles Use.

4 The Overhead Contact Systems Sub-Committee for Rail Transit Systems was formed in 2001 with the  
5 purpose of developing standards governing the design and construction of overhead contact systems for rail  
6 transit. The primary concern of the Overhead Contact Systems Sub-Committee Working Group 16 was the  
7 lack of uniform practices and applications for the design and implementation of pantographs used on rail  
8 transit vehicles.

9 The majority of the presently operating electrified rail transit systems use an overhead contact system  
10 (OCS) or third rail to supply traction and auxiliary power to the vehicles. This standard was initially  
11 developed for pantograph collection devices, and will address trolley poles and other collection devices at a  
12 later time.

13 This standard specifies:

- 14 – definitions pertaining to pantographs used on direct current (dc) or alternating current (ac)  
15 powered rail transit vehicles
- 16 – performance requirements for pantograph equipment used on dc or ac powered rail transit vehicles
- 17 – requirements for testing of pantographs used on dc or ac powered rail transit vehicles

18 This standard does not consider

- 19 – specific maintainability or reliability requirements for pantographs
- 20 – pantographs for operation on electrified main line commuter railroads or high-speed railroad  
21 systems

22 This standard is intended to apply to rail transit vehicles that are electrically powered by an overhead  
23 contact system. These rail transit vehicles are defined to include Heavy Rail Vehicles (also called subway,  
24 elevated, or rapid transit cars) and Light Rail Vehicles (also called streetcars, tramcars, or trolley cars),  
25 including units which combine powered and unpowered trucks or axles.

26 This standard does not apply to electrically powered main-line railroad vehicles, such as locomotives or  
27 electric multiple unit (EMU) cars.

28 Fully-automated, driverless rail transit vehicles are sometimes included in the mode of transit referred to as  
29 Automated Guideway Transit (AGT), and, to the extent that the vehicles do not have other unique  
30 requirements, this standard can be applied. It is not intended that this standard be universally required for  
31 all AGT systems.

32 NOTE - Self-propelled railway vehicles operating on trackage of the general railroad system are subject to  
33 regulations issued by governmental bodies (e.g., federal, state, and local bodies). In selected jurisdictions  
34 this is also true for rail transit vehicles. The user of this Standard should recognize that such regulations  
35 always take precedence over a consensus standard.

36 This standard applies to pantographs used on light rail vehicles and subway/metro rapid transit cars, where  
37 the electrical power for the operation of the propulsion and auxiliary systems is supplied from a direct  
38 current or single-phase alternating current, conventionally suspended, overhead contact system, with a  
39 nominal voltage of 600 Volts and above.

1 It is recognized that some of the parameters identified in this standard may conflict with the characteristics  
2 of pantographs that are currently in service with established operating authorities. To achieve  
3 standardization within the industry, it is recommended that operating agencies adopt the requirements of  
4 this standard to the maximum extent practicable in developing specifications for any new or replacement  
5 pantographs.

## 6 **Notice to users**

### 7 **Laws and regulations**

8 Users of these documents should consult all applicable laws and regulations. Compliance with the  
9 provisions of this standard does not imply compliance to any applicable regulatory requirements.  
10 Implementers of the standard are responsible for observing or referring to the applicable regulatory  
11 requirements. IEEE does not, by the publication of its standards, intend to urge action that is not in  
12 compliance with applicable laws, and these documents may not be construed as doing so.

### 13 **Copyrights**

14 This document is copyrighted by the IEEE. It is made available for a wide variety of both public and  
15 private uses. These include both use, by reference, in laws and regulations, and use in private self-  
16 regulation, standardization, and the promotion of engineering practices and methods. By making this  
17 document available for use and adoption by public authorities and private users, the IEEE does not waive  
18 any rights in copyright to this document.

### 19 **Updating of IEEE documents**

20 Users of IEEE standards should be aware that these documents may be superseded at any time by the  
21 issuance of new editions or may be amended from time to time through the issuance of amendments,  
22 corrigenda, or errata. An official IEEE document at any point in time consists of the current edition of the  
23 document together with any amendments, corrigenda, or errata then in effect. In order to determine whether  
24 a given document is the current edition and whether it has been amended through the issuance of  
25 amendments, corrigenda, or errata, visit the IEEE Standards Association web site at  
26 <http://ieeexplore.ieee.org/xpl/standards.jsp>, or contact the IEEE at the address listed previously.

27 For more information about the IEEE Standards Association or the IEEE standards development process,  
28 visit the IEEE-SA web site at <http://standards.ieee.org>.

### 29 **Errata**

30 Errata, if any, for this and all other standards can be accessed at the following URL:  
31 <http://standards.ieee.org/reading/ieee/updates/errata/index.html>. Users are encouraged to check this URL  
32 for errata periodically.

### 33 **Interpretations**

34 Current interpretations can be accessed at the following URL: [http://standards.ieee.org/reading/ieee/interp/  
35 index.html](http://standards.ieee.org/reading/ieee/interp/index.html).

## 1 Patents

2 *[If the IEEE has not received letters of assurance prior to the time of publication, the following notice*  
3 *shall appear:]*

4 Attention is called to the possibility that implementation of this standard may require use of subject matter  
5 covered by patent rights. By publication of this standard, no position is taken with respect to the existence  
6 or validity of any patent rights in connection therewith. The IEEE is not responsible for identifying  
7 Essential Patent Claims for which a license may be required, for conducting inquiries into the legal validity  
8 or scope of Patents Claims or determining whether any licensing terms or conditions provided in  
9 connection with submission of a Letter of Assurance, if any, or in any licensing agreements are reasonable  
10 or non-discriminatory. Users of this standard are expressly advised that determination of the validity of any  
11 patent rights, and the risk of infringement of such rights, is entirely their own responsibility. Further  
12 information may be obtained from the IEEE Standards Association.

13 *[The following notice shall appear when the IEEE receives assurance from a known patent holder or*  
14 *patent applicant prior to the time of publication that a license will be made available to all applicants*  
15 *either without compensation or under reasonable rates, terms, and conditions that are demonstrably free*  
16 *of any unfair discrimination.]*

17 Attention is called to the possibility that implementation of this standard may require use of subject matter  
18 covered by patent rights. By publication of this standard, no position is taken with respect to the existence  
19 or validity of any patent rights in connection therewith. A patent holder or patent applicant has filed a  
20 statement of assurance that it will grant licenses under these rights without compensation or under  
21 reasonable rates, with reasonable terms and conditions that are demonstrably free of any unfair  
22 discrimination to applicants desiring to obtain such licenses. Other Essential Patent Claims may exist for  
23 which a statement of assurance has not been received. The IEEE is not responsible for identifying Essential  
24 Patent Claims for which a license may be required, for conducting inquiries into the legal validity or scope  
25 of Patents Claims, or determining whether any licensing terms or conditions provided in connection with  
26 submission of a Letter of Assurance, if any, or in any licensing agreements are reasonable or non-  
27 discriminatory. Users of this standard are expressly advised that determination of the validity of any patent  
28 rights, and the risk of infringement of such rights, is entirely their own responsibility. Further information  
29 may be obtained from the IEEE Standards Association.

## 1 Participants

2 At the time this draft standard was submitted to the IEEE-SA Standards Board for approval, the Current  
3 Collectors Performance Standards Working Group had the following membership:

4 **Jeffrey N. Sisson**, *Chair*  
5 **Ronald Bennell**, *Vice Chair*  
6  
7 Jim Christoff                      12 Michael N. Lewis                      17 Suresh Shrivavle  
8 Richard Eagan                      13 Lawrence P. Mirecki                      18 Marco Taccini  
9 Lloyd Edwards                      14 Charles E. Mullen                      19 Louis A. Tobio  
10 Andrew Gillespie                      15 George Nesta  
11 Ian Hayes                      16 Alwyne Pugh

20  
21  
22 The following members of the <individual/entity> balloting committee voted on this standard. Balloters  
23 may have voted for approval, disapproval, or abstention.

24  
25 *(to be supplied by IEEE)*

26  
27 Balloter1                      30 Balloter4                      33 Balloter7  
28 Balloter2                      31 Balloter5                      34 Balloter8  
29 Balloter3                      32 Balloter6                      35 Balloter9

36  
37  
38 When the IEEE-SA Standards Board approved this standard on <XX Month 20XX>, it had the following  
39 membership:

40 *(to be supplied by IEEE)*

41 **<Name>**, *Chair*  
42 **<Name>**, *Vice Chair*  
43 **<Name>**, *Past President*  
44 **<Name>**, *Secretary*  
45  
46 SBMember1                      49 SBMember4                      52 SBMember7  
47 SBMember2                      50 SBMember5                      53 SBMember8  
48 SBMember3                      51 SBMember6                      54 SBMember9

55 \*Member Emeritus  
56  
57

58 Also included are the following nonvoting IEEE-SA Standards Board liaisons:

59 **<Name>**, *TAB Representative*  
60 **<Name>**, *NIST Representative*  
61 **<Name>**, *NRC Representative*

62 **<Name>**  
63 *IEEE Standards Program Manager, Document Development*  
64  
65 **<Name>**  
66 *IEEE Standards Program Manager, Technical Program Development*  
67

# 1 Contents

2	1. Overview .....	8
3	1.1 Scope .....	8
4	1.2 Purpose .....	8
5	2. Normative references.....	9
6	3. Definitions .....	9
7	3.1 General definitions .....	9
8	3.2 Special terms and definitions for pantograph components .....	11
9	3.3 Special terms and definitions for pantograph dimensions .....	13
10	3.4 Definitions of operating characteristics .....	15
11	3.5 Abbreviations and acronyms .....	17
12	4. Technical requirements: .....	18
13	4.1 Pantograph type .....	18
14	4.2 Operating requirements .....	18
15	4.3 Pantograph dimensions.....	19
16	4.4 Pantograph operating positions.....	19
17	4.5 Collector head and contact strip.....	20
18	4.6 Pantograph mechanical requirements .....	22
19	4.7 Pantograph operating system.....	23
20	4.8 Miscellaneous requirements .....	26
21	4.9 Maintenance requirements.....	29
22	5. Testing requirements: .....	30
23	5.1 Qualification tests:.....	30
24	5.2 Acceptance tests: .....	30
25	5.3 Investigation tests: .....	31
26	5.4 Combined tests: .....	31
27	5.5 Test configuration:.....	31
28	5.6 Test and measuring equipment: .....	31
29	5.7 Test procedures and reports:.....	31
30	5.8 Individual tests.....	31
31	Annex A (informative) Single arm pantograph terminology and components.....	47
32	Annex B (informative) Two-Arm and Four-Arm Diamond Type Pantographs .....	49
33	Annex C (normative) Pantograph collector head preferred dimensions.....	50
34	Annex D (normative) Test Requirements.....	51
35	Annex E (normative) Customer Specification Requirements.....	52
36		
37		

1 **Draft Standard for for Performance of**  
2 **dc Overhead Current Collectors for**  
3 **Rail Transit Vehicles**

4 *IMPORTANT NOTICE: This standard is not intended to ensure safety, security, health, or*  
5 *environmental protection in all circumstances. Implementers of the standard are responsible for*  
6 *determining appropriate safety, security, environmental, and health practices or regulatory*  
7 *requirements.*

8 *This IEEE document is made available for use subject to important notices and legal disclaimers.*  
9 *These notices and disclaimers appear in all publications containing this document and may*  
10 *be found under the heading “Important Notice” or “Important Notices and Disclaimers*  
11 *Concerning IEEE Documents.” They can also be obtained on request from IEEE or viewed at*  
12 *<http://standards.ieee.org/IPR/disclaimers.html>.*

13 **1. Overview**

14 **1.1 Scope**

15 This standard provides minimum acceptable performance requirements for overhead  
16 current collectors used for light rail vehicles, heavy rail vehicles and trolley bus vehicles.  
17 Specific areas to be addressed include oscillation of collectors, arcing and electrical  
18 transients, all weather operation, the wire/collector interface, and dewirement and  
19 entanglement hazards.

20 **1.2 Purpose**

21 The purpose of this standard is to develop performance requirements for overhead  
22 current collectors on transit vehicles to control hazards, improve performance and  
23 reliability, and reduce life cycle cost.

## 1 2. Normative references

2 The following referenced documents are indispensable for the application of this document (i.e., they must  
3 be understood and used, so each referenced document is cited in text and its relationship to this document is  
4 explained). For dated references, only the edition cited applies. For undated references, the latest edition of  
5 the referenced document (including any amendments or corrigenda) applies.

6 APTA Standard RT-S-VIM-002-02, Standard for Pantograph Current Collection Equipment Periodic  
7 Inspection and Maintenance  
8 IEEE Std 16™-2004, IEEE Standard for Electrical and Electronic Control Apparatus on Rail Vehicles  
9 IEEE Std 100™ -2000, IEEE Standard Dictionary of Electrical and Electronics Terms, 7th Edition  
10 IEEE Std 1476™-2000, IEEE Standard for Passenger Train Auxiliary Power Systems  
11 IEEE Std 1478™-2001, IEEE Standard for Environmental Conditions for Transit Rail Car Electronic  
12 Equipment  
13

## 14 3. Definitions

15 For the purposes of this document, the following terms and definitions apply. The IEEE-SA Standards  
16 Definitions Database should be referenced for terms not defined in this clause.

### 17 3.1 General definitions

18 **3.1.1 Abnormal wear:** Also known as “excessive wear” or “accelerated wear”. That wear of parts and  
19 components that cannot be considered as normal wear or aging when the pantograph is operated under  
20 conditions expected in light or heavy rail transit applications and in the environment specified and when it  
21 is maintained in accordance with the supplier’s approved maintenance instructions.

22 If an operating authority uses an ice cutter attached to, or made part of, the pantograph contact strip, and/or  
23 operates following an ice or a sleet storm, it is likely that a shorter life will result for the contact strip and  
24 the overhead contact wire. The definition of abnormal wear and calculation of normal service life shall not  
25 apply to the period of time that ice cutters are in service, or when there is ice and sleet buildup on the  
26 overhead wire.

27 **3.1.2 Approval:** Reviewed and accepted, in writing by the customer.

28 **3.1.3 Approved or approved type:** The type, material, procedure, or method as reviewed and accepted in  
29 writing by the customer.

30 **3.1.4 Car:** A complete transit vehicle assembly, in a ready to operate condition and configuration.

31 **3.1.5 Carbody:** The part of the transit vehicle that includes the structure (sides, floor, roof, ends, with  
32 interior linings and panels), and the brackets on which the pantograph assembly mounts.

33 **3.1.6 Car builder:** The entity assembling or manufacturing the transit vehicle on which the pantograph is  
34 to be used.

35 **3.1.7 Customer:** The entity purchasing or ordering the pantograph, which may be either the operating  
36 authority or the car builder.

37 **3.1.8 Failure:** Any malfunction which requires unscheduled maintenance, repair or replacement of the  
38 pantograph assembly or its components. Secondary failures resulting from failure of another system or

1 component shall not be considered as failures unless it is determined that protective elements integral to the  
 2 apparatus in which the secondary failure occurred should have been provided or that such provisions were  
 3 ineffective. Failures resulting from accidents, or caused by outside unrelated events, such as collisions,  
 4 vandalism or negligence, shall not be considered as failures. Expendable items which are subject to normal  
 5 wear, aging, or loss of effectiveness, such as contact strip carbon inserts or air filters, shall not be  
 6 considered failures when they reach the end of their normal, useful life span. However, if they do not  
 7 perform adequately within their expected life or if they are a contributing cause to subsequent defects in  
 8 other apparatus, they shall be considered failures.

9 **3.1.9 Gradient of overhead contact wire:** The Gradient of Overhead Contact Wire is usually expressed as  
 10 a percent, and is defined by Equation (1):

$$11 \quad G = H/S \times 100 \quad (1)$$

12 where

13  $G$  is gradient,

14  $H$  is height change above rail

15  $S$  is the horizontal distance between points of height measurement

16 A rising gradient is where the overhead contact wire increases in height over the specified distance. A  
 17 falling gradient is where it decreases in height over the specified distance.

18 **3.1.10 Heavy rail transit:** A mode of rail rapid transit generally characterized by fully grade-separated  
 19 construction, operation on exclusive rights of way, with high level station platforms at the floor level of the  
 20 vehicles. Also known as “rapid rail”, “subway”, “elevated railway”, or “metropolitan railway (metro)”.

21 **3.1.11 Heavy rail vehicle:** A vehicle operating on a heavy rail transit system. Typically, electrically  
 22 propelled, bi-directional, capable of operating in multiple unit, and designed for rapid, high-level boarding  
 23 and discharging of passengers.

24 **3.1.12 Light rail transit:** A mode of rail transit characterized by its ability to operate on exclusive rights-  
 25 of-way, street running, center reservation running, and grade crossings and to board and discharge  
 26 passengers at track or vehicle floor level. Also known as “streetcar”, “tramway”, or “trolley car”.

27 **3.1.13 Light rail vehicle:** A vehicle which operates on a light rail transit system, capable of boarding and  
 28 discharging passengers at track or vehicle floor level.

29 **3.1.14 Low voltage power supply (LVPS):** A power supply, which provides dc power to the low voltage  
 30 devices or circuits contained on the vehicle. It can also be configured to charge the vehicle battery.

31 **3.1.15 Operating authority:** A geographical or political division created specifically for the single purpose  
 32 of providing transportation service.

33 **3.1.16 Rigid contact system:** An overhead contact system often found in maintenance shops and at  
 34 moveable bridges. It uses an un-tensioned, self-supporting contact wire relying on continuous support,  
 35 (such as proprietary aluminum or copper-based extrusions or “T”-bars) or ‘barn hangers’ at close spacing to  
 36 supply the necessary rigidity.

37

1 **3.1.17 Service proven:** Also known as “proven”. The historical and documented success of pantograph  
 2 equipment operating on a fleet of vehicles for a minimum of 6.4 million fleet kilometers (4,000,000 fleet  
 3 miles), or for a minimum of two (2) years, of scheduled revenue service under similar conditions on other  
 4 light rail or heavy rail vehicles.

5 **3.1.18 Supplier:** The manufacturer of the pantograph.

6 **3.1.19 Vehicle:** A land conveyance assembly for carrying or transporting people or objects, capable of  
 7 traversing a guideway, having structural integrity and general mechanical completeness but not necessarily  
 8 designed for independent operation.

## 9 **3.2 Special terms and definitions for pantograph components**

10 The various components of the pantograph are described in this subclause and shown in Figure A.1 of  
 11 Annex A.

12 **3.2.1 Pantograph:** A multi-link hinged apparatus that collects current from one or more overhead contact  
 13 wires for use by the vehicle propulsion and auxiliary electrical systems. The collector head of the  
 14 pantograph moves vertically to conform to changes in height of the overhead contact wire.

15 In the up, or operating, position the pantograph is in contact with the overhead contact wire and is entirely,  
 16 or partially, under voltage, depending on the state of energization of the overhead contact wire.

17 In the down, or stowed, position, the pantograph is locked down and not in contact with the overhead  
 18 contact wire or any part of the overhead contact system.

19 There are two (2) basic types of pantographs for light rail and heavy rail operations. These are the single  
 20 arm type and the diamond type. The diamond type is usually available in the two-arm and four-arm  
 21 configurations. The single arm type is shown in Figure A.1 of Annex A. The two-arm and four-arm  
 22 diamond types are shown in Figures B.1 and B.2 respectively of Annex B.

23 **3.2.2 Pantograph assembly:** A pantograph assembly consists of a base frame, electrical insulators, a frame  
 24 assembly, a primary suspension, a collector head assembly, a secondary suspension, and an operating  
 25 system. In some situations, a pantograph can include a breakaway mechanism or an automatic drop down  
 26 mechanism.

27 NOTE: The components identified in Section 3.2.2 form a complete pantograph assembly. Most of these components  
 28 are identified in Figure A.1 in Annex A.

29 **3.2.2.1 Base frame (item 1):** The fixed part of the pantograph which supports the pantograph frame  
 30 assembly and is mounted on the electrical insulators.

31 **3.2.2.2 Frame insulators (item 2):** Electrical insulators that attach to the base frame and mount on the  
 32 vehicle roof by suitable brackets. These electrical insulators mechanically support the base frame and  
 33 electrically insulate it from the carbody.

34 **3.2.2.3 Pantograph mounting plane (item 3):** A horizontal plane, or a multi-layer surface, described by  
 35 the bottom mounting surface of the electrical insulators when attached to the base frame.

36 **3.2.2.4 Pantograph frame assembly (item 4):** A multi-element hinged assembly which enables the  
 37 collector head to move in a vertical or nearly vertical direction with respect to the base plane of the  
 38 pantograph and to remain in a horizontal or level position. While there may be variations on the design,  
 39 basic components of the pantograph frame might generally include upper and lower struts (items 4a and 4b  
 40 respectively) and upper and lower guide rods (items 4c and 4d respectively). These items are also known

1 as the upper frame (item 4a), lower frame (item 4b), collector head and pan-guide (item 4c), and coupling  
2 rod (item 4d) respectively.

3 **3.2.2.5 Primary suspension (item 5):** A system of springs and dampers or shock absorbers attached  
4 between the pantograph frame assembly and the base frame to cushion the dynamic motion of the  
5 pantograph frame. The primary suspension is usually spring, pneumatically or electrically actuated and  
6 functions to provide for a smooth and controlled vertical motion, to provide a constant force on the  
7 overhead contact wire, and to dampen out any oscillations in the pantograph frame assembly.

8 **3.2.2.6 Collector head assembly (items 6a to 6e):** That part of the pantograph which is supported by the  
9 pantograph frame and contacts the overhead wire. The collector head includes an optional secondary  
10 suspension (item 6a), one or more contact strips (item 6b), and end horns (item 6c), mechanically  
11 connected by the head frame. These components are defined below:

12 (a) **Secondary suspension (item 6a):** Also called “collector head suspension” or “pan head  
13 suspension”. Spring and damper assemblies that support the collector head on the pantograph frame  
14 at the pivot, or each contact strip assembly separately on the head frame, and absorb small shock  
15 loads and oscillations, preventing them from being transmitted to the pantograph frame, and  
16 improving pantograph tracking ability.

17 (b) **Contact strip (item 6b):** Also called “carbon” or “rubbing strip”. The replaceable wearing part of  
18 the collector head assembly which interfaces with the overhead contact wire for collecting current.  
19 The contact strip may be in the form of extruded carbon inserts that are slid into a socket rail, or in the  
20 form of carbon strips bonded, soldered or bolted to a metal backing plate. In all cases, the contact  
21 strip includes the carbon inserts with the metal socket rail or backing plate.

22 (c) **End horns (item 6c):** The ends of the collector head assembly which ensure smooth engagement  
23 with, or disengagement from, any overhead contact wire that is entering or leaving the running wire,  
24 or with a running overhead contact wire that moves beyond the end of the contact strip.

25 (d) **End horn hook (item 6d):** A hook at the outer end of the horn that serves to catch the overhead  
26 contact wire and prevent it from moving under the end of the end horn and fouling the collector head.

27 (e) **Collector head pivot (item 6e):** That pivot, with axis transverse to the longitudinal centerline of  
28 the vehicle, which enables slight rotational or pitching motion of the collector head assembly, in  
29 response to transitions in the gradient of the overhead contact wire or to overhead wire and pantograph  
30 system kinematic tolerances.

31 **3.2.2.7 Manual emergency operating system (item 7):** A general term to describe secondary devices  
32 which enable raising or lowering the pantograph frame when the primary operating system, defined in  
33 3.2.2.10, is not available or if the vehicle is completely shut down with no electrical or pneumatic power  
34 being available.

35 The following lists several major methods of emergency operation that may be available:

- 36 • Hand crank for raise and lower
- 37 • Rope for release of lock-down latch to raise
- 38 • Rope for pull-down of pantograph frame to lower
- 39 • Hand or foot actuated air pumps for raise and lower
- 40 • Hand or foot actuated hydraulic pumps for raise and lower

- 1           • Lever for release of lock-down latch to raise

2 Item 7 of Figure A.1 shows a manual release lever.

3 **3.2.2.8 Electrical shunts (item 8):** Electrical cables that are constructed from extra-flexible, braided  
4 conductors of tinned copper wire and carry current around bearings and other parts where the passage of  
5 current through such items would be injurious shall be provided. These shunts shall be provided with lugs  
6 crimped to the shunt wire and bolted to the pantograph members with bolts, washers and nuts. The shunts  
7 are usually not insulated.

8 **3.2.2.9 Auto drop/breakaway mechanism (not illustrated):** A mechanism that automatically causes the  
9 pantograph to lower whenever the pantograph encounters an obstruction or some other anomaly in the  
10 overhead contact system where, if the pantograph were not to automatically lower, severe damage to the  
11 pantograph and/or overhead contact system could result, and/or personnel or passenger injury would be  
12 created.

13 **3.2.2.10 Operating system:** An electrically, pneumatically, or mechanically activated device that provides  
14 a suitable force to raise and/or lower the pantograph.

15 The following lists the different methods of activation that are available:

- 16           • Spring raise and electric lower  
17           • Spring raise and pneumatic lower  
18           • Pneumatic raise and spring lower  
19           • Pneumatic raise and lower

## 20 **3.3 Special terms and definitions for pantograph dimensions**

21 The dimensions of the pantograph assembly are defined in this subclause and are identified in Figure A.1 in  
22 Annex A.

23 Each of these dimensions, with appropriate tolerances, shall be specified on an outline drawing of the  
24 pantograph, which drawing shall be submitted by the supplier to the customer for review and approval.

25 **3.3.1 Base frame length (FL):** The outside width of the pantograph base frame, measured longitudinally in  
26 relation to the vehicle.

27 **3.3.2 Base frame width (FW):** The outside width of the pantograph base frame, measured transversely in  
28 relation to the vehicle.

29 **3.3.3 Collector head angle (AH):** The angle included by the intersection at the Collector Head Pivot Axis  
30 of two lines each connecting the Collector Head Pivot Axis with the outermost top edge of the leading and  
31 trailing contact strips at the longitudinal centerline of the vehicle. (where the contact strips intersect a  
32 vertical plane through the longitudinal centerline of the vehicle).

33 **3.3.4 Distance between contact strip centerlines (SC):** The distance between the centerlines of the  
34 contact strips, measured longitudinally in relation to the vehicle.

35 **3.3.5 Height of collector head (HH):** The vertical distance between the lowest point of the end horns and  
36 the uppermost point of the contact strips.

- 1 **3.3.6 Insulator height (IH):** The distance between the top and bottom mounting surfaces of the electrical  
2 insulators.
- 3 **3.3.7 Insulator mounting spacing - longitudinal (IL):** The distance between the centers of the bottom  
4 surface of the electrical insulators, where fasteners attach the insulators to the car roof, measured  
5 longitudinally in relation to the vehicle
- 6 **3.3.8 Insulator mounting spacing – transverse (IT):** The distance between the centers of the bottom  
7 surface of the electrical insulators, where fasteners attach the insulators to the car roof, measured  
8 transversely in relation to the vehicle.
- 9 **3.3.9 Length of collector head (LH):** The length of the collector head is measured transversely in relation  
10 to the vehicle over the end horns, but not over the end horn hooks.
- 11 **3.3.10 Length of contact strip(s) (LC):** The total length of the contact strips measured transversely in  
12 relation to the vehicle.
- 13 **3.3.11 Lock down height (HL):** The vertical distance between the pantograph mounting plane and the  
14 upper surface of the contact strips with the pantograph in the locked-down and stowed position, as  
15 measured at a vertical plane through the longitudinal centerline of the vehicle.
- 16 **3.3.12 Maximum extended height (HME):** The vertical distance between the pantograph mounting plane  
17 and the upper surface of the contact strips with the pantograph raised to its highest level as limited by  
18 mechanical stops, as measured at a vertical plane through the longitudinal centerline of the vehicle.
- 19 **3.3.13 Maximum working height (HMAX):** The vertical distance between the pantograph mounting plane  
20 and the upper surface of the contact strips with the pantograph raised to the highest level at which it is  
21 designed to collect current, as measured at a vertical plane through the longitudinal centerline of the  
22 vehicle.
- 23 **3.3.14 Minimum working height (HMIN):** The vertical distance between the pantograph mounting plane  
24 and the upper surface of the contact strips with the pantograph raised to the lowest level at which it is  
25 designed to collect current, as measured at a vertical plane through the longitudinal centerline of the  
26 vehicle.
- 27 **3.3.15 Overall length (OL):** The length of the pantograph from the front surface of the base frame to the  
28 extreme end of the lower guide rod, when the pantograph is in its lowest possible position, measured  
29 longitudinally in relation to the vehicle.
- 30 **3.3.16 Overall width (OW):** The maximum width of the pantograph, excluding the collector head,  
31 measured transversely in relation to the vehicle, over the extreme ends of the base frame or the pantograph  
32 components, whichever is wider,
- 33 **3.3.17 Radius of contact strip (RC):** The average radius of the contact surface of a new and unworn  
34 contact strip.
- 35 If the contact strip is not formed to a specific radius over its length, LC, the equivalent radius of the contact  
36 strip is defined as the radius of a circle described by three (3) points on the top surface of the contact strip,  
37 the two ends of the contact strip and the center.
- 38 **3.3.18 Width of collector head (WH):** The width of collector head is measured longitudinally in relation  
39 to the vehicle, at the top surface and over the outside of the contact strips.
- 40 The width of the collector head is related to the width of the contact strip WC and the distance between  
41 contact strips SC by Equation (2):

1  $WH = SC + WC$  (2)

2 where

3  $WH$  = width of collector head

4  $SC$  = distance between contact strips

5  $WC$  = width of a contact strip

6 **3.3.19 Width of contact strip (WC):** The width of the surface of the contact strip that contacts the  
7 overhead contact wire.

8 **3.3.20 Working range (WR):** The difference between the minimum and maximum working heights of the  
9 pantograph. This is the dynamic range over which the pantograph will normally operate, as measured at a  
10 vertical plane through the longitudinal centerline of the vehicle.

## 11 3.4 Definitions of operating characteristics

12 In the following definitions, it is assumed that the maximum and continuous values of current, voltage,  
13 speed and force do not result in any deformation or degradation of any pantograph component or part  
14 thereof.

15 **3.4.1 Continuous operating voltage range:** The anticipated minimum and maximum system voltages  
16 within which the pantograph is expected to continuously operate.

17 **3.4.2 Degrees of freedom of the collector head:** The rotation and/or movement of the collector head about  
18 the collector pivot, vehicle centerline and vertical axis. Also known as collector head pitch, roll and yaw  
19 respectively.

20 **3.4.3 Maximum current, vehicle at standstill:** The current, guaranteed by the manufacturer, which the  
21 pantograph can withstand for at least one-and-a-half (1-1/2) minutes (90 seconds) with the vehicle at  
22 standstill, with a given type and number of contact strips.

23 NOTE – This requirement is based on conditions such as short circuit currents in the traction equipment, locked rotor  
24 traction motor currents, and other considerations..

25 **3.4.4 Maximum permissible pantograph frame vertical speed:** The maximum vertical velocity at which  
26 the pantograph can rise or fall within the working range, such as when negotiating gradients in the overhead  
27 contact wire, without incurring pantograph frame instability and/or intermittent contact with the overhead  
28 contact wire (otherwise called “pantograph bounce”), and at which the dynamic force can be maintained.

29 NOTE - The maximum permissible pantograph frame vertical speed is not at all related to the pantograph  
30 raising and lowering speed. These are entirely different parameters with differing requirements.

31 **3.4.5 Nominal static force:** The nominal static force is based on an average of the static force measured at  
32 a minimum of four (4) different positions during the raising and lowering phases of the pantograph, as  
33 follows:

34 Minimum Working Height (HMIN)

35 One--third (1/3) of the Working Range (WR) above the Minimum Working Height (HMIN)

36 Two--thirds (2/3) of the Working Range (WR) above the Minimum Working Height (HMIN)

1 Maximum Working Height (HMAX)

2 The same point of measurement shall be used for each phase. The speed of raising and lowering during this  
3 measurement shall be as specified.

4 The average of the static forces measured in the raising phase shall be calculated and the result denoted as  
5 *F<sub>m</sub>*. Similarly, *F<sub>a</sub>* is the average of the static forces measured in the lowering phase.

6 The nominal static force is given by Equation (3)

$$7 \quad (F_m + F_a)/2 \quad (3)$$

8 Where

9 *F<sub>m</sub>* is the average of the static forces measured in the raising phase

10 *F<sub>a</sub>* is the average of the static forces measured in the lowering phase

11 **3.4.6 Nominal supply voltage:** The nominal dc or ac system voltage that is the basis of the design of the  
12 pantograph and at which it is to function. Nominal supply voltages, including the minimum and maximum  
13 continuous voltages and the maximum short time voltages, for high-voltage dc-powered traction and  
14 auxiliary apparatus powered from a dc source such as an overhead contact system or a third rail are  
15 discussed in Clause 4.2.

16 **3.4.7 Pantograph tracking:** Also called “pantograph commutation”. The ability of the pantograph to  
17 allow stable contact and smooth operation, and current collection without arcing, between the collector  
18 head contact strips and the overhead contact wire. This means that the contact strips follow and maintain  
19 contact, at the prescribed force, with the overhead contact wire through all its changes in height, changes  
20 from one contact wire to another (overlaps), through section breaks, insulators, isolators and runners, and  
21 through irregularities expected in an overhead contact wire system.

22 NOTE - Irregularities in the OCS can cause pantograph bounce which may be sufficiently severe as to cause  
23 momentary “loss of contact” between the contact strips and the contact wire. Loss of contact may result in arcing and  
24 creation of radio frequency interference, so it should be minimized to the greatest extent practicable. It is  
25 recommended that the pantograph and OCS designers work together to ensure that, under worst case operating  
26 conditions, there is no discernable loss of contact or no discernable interruptions of current being collected. Such  
27 interruptions of current should not exceed the minimum required for initiating a shutdown or pause in the operation of  
28 vehicle equipment or apparatus, or operation of protective devices.

29 **3.4.8 Rated current, vehicle at standstill:** The current, guaranteed by the manufacturer, which the  
30 pantograph can continuously withstand with the vehicle at standstill, with a given type and number of  
31 contact strips.

32 **3.4.9 Rated current, vehicle running:** The current, guaranteed by the manufacturer, which the pantograph  
33 can continuously collect, with a given type and number of contact strips, from the overhead contact wire  
34 with the vehicle operating at any speed greater than standstill and up to the rated speed.

35 **3.4.10 Rated operating speed:** The maximum vehicle speed at which the manufacturer guarantees  
36 satisfactory rated current collection from an overhead contact wire of specified characteristics.

37 NOTE - The rated operating speed is not necessarily the same as the maximum possible speed of the vehicle. The rated  
38 operating speed should take into account the maximum allowable overspeed of the vehicle and any allowable vehicle  
39 overspeed. The maximum possible speed is that which the vehicle could attain if operating constraints were removed.

1 **3.4.11 Retaining force in locked down position:** That minimum upward vertical force which must be  
 2 exceeded for the pantograph to move out of the locked down and stowed position. This applies only to  
 3 pantographs that do not employ a positive mechanical latch assembly, For pantographs that do employ a  
 4 positive mechanical latch assembly, any upward force that causes the latch to release would be excessive  
 5 and would cause damage or distortion of pantograph components.

6 **3.4.12 Static force:** The vertical force exerted upward by the collector head on the overhead contact wire.  
 7 This force is caused by the action of the pantograph raising device and the primary suspension, with the  
 8 pantograph raised and with the vehicle at standstill.

9 **3.4.13 Total force at any given speed:** Also known as the “aerodynamic force” or the “dynamic force”.  
 10 The sum of the static force and the vertical force produced as a result of the air-flow at the speed in  
 11 question.

## 12 **3.5 Abbreviations and acronyms**

13	APTA	American Public Transportation Association
14	IEEE	Institute of Electrical and Electronic Engineers
15	LVPS	Low Voltage Power Supply
16	OCS	Overhead Contact System
17	PSIG	Pounds per Square Inch Gauge

18

## 1 4. Technical requirements:

2 Pantographs are to comply with the following technical requirements. Many of these requirements may not  
3 be compatible with a particular operating authority's clearances or operational environment. In those cases  
4 the customer shall specify the requirement.

5 Unless otherwise stated, whenever the word "specified" is used, it is to be by the customer.

### 6 4.1 Pantograph type

7 The type of pantograph to be supplied shall be specified. The preferred pantograph is the single-  
8 arm type.

### 9 4.2 Operating requirements

10 The following operating requirements shall be specified:

- 11 – Nominal supply voltage
- 12 – Continuous operating voltage range: Unless otherwise specified, the dc and ac standard  
13 voltage ranges of 4.2.4 of IEEE Std. 16™, shown below as Tables 1 and 2 respectively,  
14 shall apply.

15 **Table 1**

16 Standard voltages for high-voltage dc-powered traction and auxiliary apparatus  
17 powered from a dc source

Nominal system voltage (V)	Operating voltage range		
	Minimum continuous	Maximum continuous	Maximum short time
600	420	720	800
750	525	900	1 000
1 500	1 050	1 800	1 950
3 000	2 100	3 600	3 900

18

1  
2**Table 2**

Standard voltages for high-voltage single-phase ac systems

Nominal System Voltage	Nominal Frequency (Hz)	Operating Voltage Range			
		Minimum Short-time	Minimum Continuous	Maximum Continuous	Maximum Short-time
12 000	25	8 400	9 600	13 200	14 400
12 500	60	8 750	10 000	13 750	15 000
25 000	60	17 500	20 000	27 500	30 000
50 000	60	35 000	40 000	55 000	60 000

3

4

– Rated current, vehicle at standstill

5

– Maximum current, vehicle at standstill

6

– Rated current, vehicle running

7

– Maximum gradient of the overhead contact wire in relation to vehicle speed

8

– Maximum change in gradient of the overhead contact wire at a support point

9

– Rated operating speed

10

– Maximum vehicle overspeed

11

– Vehicle consist if multiple vehicle operation is considered

12

**4.3 Pantograph dimensions**

13

The following physical dimensions of the pantograph, as defined in 3.3, shall be specified:

14

– Insulator mounting spacing - longitudinal (IL)

15

– Insulator mounting spacing – transverse (IT)

16

– Insulator height (IH) (see 4.8.5)

17

– Frame width (FW)

18

– Frame length (FL)

19

– Overall length (OL)

20

– Overall width (OW)

21

**4.4 Pantograph operating positions**

22

The following operating positions for the pantograph shall be specified:

23

– maximum working height (HMAX)

24

– minimum working height (HMIN)

25

– lock-down height (HL)

26

The Maximum Extended Height (HME) shall be sufficiently greater than the Maximum working height

27

(HMAX) such that the pantograph does not extend to the Maximum extended height and hit the stops

28

during anticipated normal operating conditions.

## 1 **4.5 Collector head and contact strip**

### 2 **4.5.1 Length of the collector head:**

3 The length of the collector head shall be specified. The preferred length of the collector head is 1 980 mm  
4 (78 in).

### 5 **4.5.2 Width of the collector head:**

6 The collector head shall include two (2) contact strips unless otherwise specified.

7 The distance between the contact strip centerlines (SC) shall be specified. The preferred distance between  
8 contact strip centerlines is 300 mm (11.81 in).

9 Taking into consideration the contact strip width (WC), the width of the collector head (WH) shall be not  
10 less than that required to sustain the collector head angle required in 4.5.3. The objective is to achieve  
11 stable contact and smooth operation between the collector head and the overhead contact wire, during  
12 normal operating conditions.

### 13 **4.5.3 Collector head angle:**

14 The collector head angle (AH) shall be a minimum of 140-degrees.

15 NOTE – A collector head angle of 140-degrees is recommended to achieve stability in operation. Frictional drag  
16 between the contact strip and the overhead contact wire may cause mechanical instability of the collector head  
17 assembly. This frictional drag produces a turning moment causing increased contact force on the leading contact strip,  
18 promoting increased current transfer through that strip. The wider the spacing of the collector strips the larger the pivot  
19 angle and, from practical and theoretical testing over the years, it has been found that a minimum angle of 140-degrees  
20 should be achieved between the pivot point and the top outer edges of the contact strips.

### 21 **4.5.4 Contact strips:**

22 The length of the contact strip (LC) shall be specified. The preferred length of the contact strips is 1 066.8  
23 mm (42 in).

24 The width of the contact strip (WC) shall be specified. The preferred width of the contact strip is 60 mm  
25 (2.36 in).

26 The contact strip shall incorporate a high-strength self-lubricating carbon insert, which shall include the  
27 appropriate percentage of copper content for the application. The composition of the contact strip material  
28 shall be optimized for the vehicle operating characteristics and to maximize service life for both the contact  
29 strips and the contact wire.

30 The carbon insert shall not include any lead, or any other heavy metals.

31 The type of contact strip shall be specified. The preferred type of contact strip is a single piece carbon  
32 insert, 20 millimeters (0.79-in) thick, bonded or soldered to a backing strip that has a 10 meter (32.81 feet)  
33 radius, with the ends of the carbon insert machined at a five (5) degree angle such that, when mounted in  
34 the collector head, the contour is in accordance with Figure C.1 of Annex C. This results in an equivalent  
35 radius of 6.18 meters (20.3 feet).

1 Alternatively, the entire top surface of the contact strip, from end-to-end, may be contoured or rolled to a  
2 constant radius (RC) of 6.18 meters (20.3 feet).

3 If the length of the contact strip specified is such that a single-piece curved, bonded or soldered type design  
4 cannot be economically produced, a design that utilizes two (2) carbon inserts bonded or soldered to a  
5 backing plate may be used, with the mating ends of the inserts cut at an angle and tight-fitting.

6 If a straight three-piece design with the strips mounted in a socket rail or other suitable support member is  
7 specified, the center piece shall extend a minimum of two (2) inches outside or end a minimum of two (2)  
8 inches inside the limits of the normal maximum stagger of the overhead contact wire.

#### 9 **4.5.5 End horns:**

10 End horns shall be of the one-piece, closed shape type, where a single end horn assembly is attached to the  
11 contact strip backing strip and abuts the ends of both carbon strips on each side of the collector head  
12 assembly. No substantial gaps shall exist between carbon strip and end horn.

13 Alternatively, single end horns, where each end of each collector strip has a separate end horn, may be  
14 specified. No substantial gaps shall exist between carbon strip and end horn.

15 If each contact strip has its own independent secondary suspension, then a single horn connecting both  
16 contact strips together cannot be used.

17 The profile of end horns shall be in accordance with Figure C.1 of Annex C.

18 The incorporation of an end horn hook shall be specified. The preferred configuration is to include an end  
19 horn hook that is cast as part of the end horn.

#### 20 **4.5.6 Height of the collector head:**

21 The height of the collector head (HH) shall be specified. The preferred height of the collector head is 250  
22 mm (9.84 in).

#### 23 **4.5.7 Secondary suspension:**

24 If specified, a secondary suspension shall be provided to facilitate pantograph tracking.

#### 25 **4.5.8 Collector head degrees of freedom:**

26 The degrees of freedom of the collector head shall be specified. In the absence of such specification, the  
27 pantograph manufacturer shall analyze the proposed or existing operating environment and shall  
28 recommend the degrees of freedom such that pantograph tracking is optimized.

29 In the absence of any specification or agreement, the collector head shall have three (3) degrees of freedom,  
30 with a pitch angle of  $\pm 10$  degrees, a collector head roll of  $\pm 5$  degrees, and a yaw angle of  $\pm 5$  degrees.

## 1 4.6 Pantograph mechanical requirements

### 2 4.6.1 Lateral deviation of the collector head:

3 The maximum lateral displacement of the collector head with respect to the vertical centerline of the base  
 4 frame, when the pantograph is raising or lowering, either by operator action or by the rise or fall of the  
 5 overhead contact wire, shall be as shown in Table 3:

6 **Table 3**

7 **Maximum lateral displacement of collector head**

Height Above Lock-Down	Maximum Lateral Displacement from Center Line
Less than 1 meter (3.28 ft)	± 10 mm (0.40 in)
Between 1 and 2 meters (3.28 to 6.56 ft)	± 20 mm (0.79 in)
Greater than 2 meters (6.56 ft)	± 30 mm (1.18 in)

### 9 4.6.2 Static force:

10 The nominal static force and range with the pantograph rising ( $F_m$ ), and the adjustment range, shall be  
 11 specified. The preferred nominal static force with the pantograph rising shall be 93.4 Newtons (21 Pounds-  
 12 Force) if contact strips of the preferred width of 60 mm (2.36 in) required in 4.5.4 are used, and shall be  
 13 adjustable to between 62 and 125 Newtons (14 and 28 Pounds-Force).

14 If 45 mm (1.77 in) wide contact strips are used, the nominal static force with pantograph rising shall be 80  
 15 Newtons (18 Pounds-Force), and shall be adjustable to between 62 and 125 Newtons (14 and 28 Pounds-  
 16 Force).

17 The maximum difference between the forces  $F_m$  and  $F_a$  shall be 10 Newtons (2.3 Pounds-Force).

18 The static force tolerances measured during the raising or lowering of the pantograph, either by operator  
 19 action or by the rise or fall of the overhead contact wire, shall be as shown in Table 4:

20 **Table 4**

21 **Static Force Requirements**

Percent of Working Range (above lower operating position)	Deviation from Nominal Static Force
WR less than 20 percent	± 15 Newtons (± 3.4 Pounds-Force)
WR between 20 and 80 percent	± 10 Newtons (± 2.3 Pounds-Force)
WR greater than 80 percent	± 15 Newtons (± 3.4 Pounds-Force)

22

1 **4.6.3 Total force:**

2 The total force shall be essentially equal to the static force. Any vertical aerodynamic force produced as a  
3 result of the air flow at any vehicle operating speed or direction of travel shall not exceed ten (10) percent  
4 of the static force.

5 The design of the pantograph shall be such that the vertical force produced as a result of the air flow at any  
6 speed, up to rated speed, shall not be affected by the shape of the vehicle or by the direction of travel.

7 **4.6.4 Pantograph transverse rigidity:**

8 When a transverse (lateral) force of 300 Newtons (67.5 Pounds-Force) is applied to the collector head pivot  
9 defined in 3.2.2.6(e) at various pantograph heights, the maximum deflection of the collector head shall be  
10 as shown in Table 5:

11 **Table 5**  
12 **Pantograph Transverse Requirements**

Height Above Lock-Down	Maximum Lateral Displacement from Center Line
Less than 2 meters (6.56 ft)	± 20 mm (± 0.79 in)
Between 2 and 3 meters (6.56 and 9.84 ft)	± 30 mm (± 1.18 in)
Greater than 3 meters (9.84 ft)	± 40 mm (± 1.57 in)

13  
14 No permanent deformation shall occur under these conditions.

15 **4.6.5 Retaining force in locked down position**

16 If the pantograph employs a methodology for retaining the pantograph in the locked down position other  
17 than the use of a positive mechanical latch assembly, the retaining force in the locked down position shall  
18 be determined by agreement between the customer and supplier.

19 **4.6.6 Maximum permissible vertical speed of pantograph frame:**

20 The maximum permissible vertical speed of the pantograph frame shall be greater than that which results  
21 from the pantograph negotiating the maximum specified overhead contact wire gradients with the vehicle  
22 operating at the specified maximum vehicle speed.

23 The preferred maximum permissible vertical speed of the pantograph frame shall be 0.15 meters per second  
24 (0.5 feet per second).

25 **4.7 Pantograph operating system**

26 **4.7.1 Operating system requirements:**

27 The operating system shall be operable by vehicle pneumatic and/or low voltage power, as specified by the  
28 operating authority. In either case, the operating system shall be service proven.

1 The operating system shall be designed such that any loss of contact with the overhead contact wire shall  
 2 not cause any permanent damage to the overhead contact wire or to the pantograph, under normal operating  
 3 conditions or at any vehicle speed, up to and including the maximum vehicle speed.

#### 4 **4.7.1.1 Raising and lowering times:**

5 The operating system shall be designed to allow the pantograph to rise from the lock-down height to any  
 6 height within the working range in a time approximating five (5) seconds from the moment the pantograph  
 7 starts to rise with full pneumatic pressure or voltage applied to the operating system. The pantograph shall  
 8 rise in a smooth and steady manner, and with the collector head level.

9 The collector head shall softly contact the overhead contact wire without any impact or significant rebound  
 10 that would be injurious to the contact strip or to the overhead contact wire. Special attention shall be given  
 11 to raising the pantograph onto a rigid contact system, such as can be found in vehicle maintenance  
 12 facilities.

13 The operating system shall be designed to lower the pantograph from the maximum working height to lock-  
 14 down in a time approximating five (5) seconds with full pneumatic pressure or voltage applied to the  
 15 operating system and without causing any damage.

#### 16 **4.7.1.2 Electrical operating system requirements:**

17 If an electrical operating system is required, the nominal battery operating voltage of the equipment shall be  
 18 specified. For the particular nominal battery voltage specified, the nominal, minimum, and maximum  
 19 operating voltage for any electrical component used in the operating system (e.g. motor, solenoid valve)  
 20 shall be in accordance with Table 6 below, which includes the requirements for nominal supply voltages  
 21 and ranges for low-voltage power supplies as given in 4.4.3 of IEEE Std 1476™-2000.

22 **Table 6**  
 23 **Standard Operating Voltages for Low-voltage Auxiliary Equipment**

Nominal Battery Voltage	Nominal LVPS Output Voltage at 25°C (77°F)	Minimum Voltage at Load	Maximum Voltage at Load
24	28.5	17.0	34.0
32	37.5	23.0	42.5
48	57.0	34.0	68.0
64	74.0	46.0	85.0

24

25 If an electric motor is used for raising and/or lowering the pantograph, the motor shall be designed and  
 26 constructed to successfully operate under the environmental conditions of IEEE Std. 1478™-2001. The  
 27 electrical ratings and requirements and the temperature rise limits shall be in accordance with IEEE Std.  
 28 16™-2004. All other electrical components, including wiring and cabling, shall meet the applicable  
 29 requirements of IEEE Std. 16™-2004.

#### 30 **4.7.1.3 Pneumatic operating system requirements:**

31 If a pneumatic system is used for raising and/or lowering the pantograph, a suitable pressure regulator, air  
 32 filter and air dryer (as appropriate for the application), pneumatic hoses (impervious to ultraviolet light,  
 33 vibration, and weather), and an in-line electrical insulator to electrically isolate the pneumatic tubing from  
 34 the vehicle air piping, shall be provided.

1 The regulator accuracy shall be 0.075 bar (1.1 psig).

2 The pneumatic pressures used for the operating system shall be specified as nominal, minimum, and  
3 maximum values by the operating authority. In the absence of specified values, the ratio of maximum to  
4 minimum pressure shall be 1.8:1 or greater and the maximum pressure shall not exceed 10.4 bar (151 psig).

#### 5 **4.7.1.4 Pantograph lock-down:**

6 The method for retaining the pantograph in the lock down position may be mechanical, pneumatic or  
7 electrical, or a combination thereof. The method shall be service proven and shall not release the  
8 pantograph unless a raise command is given by the operating system or the manual emergency release  
9 system. Any wear or service loosening of the components used for maintaining the pantograph in the lock  
10 down position shall not result in inadvertent raising of the pantograph.

#### 11 **4.7.2 Manual emergency operating system:**

12 A manual system for raising and lowering the pantograph frame in a controlled manner in an emergency  
13 shall be included. The methodology, whether through mechanically or pneumatically activated devices,  
14 shall be specified

15 This system shall be fully functional if the primary operating system is non-functional, if the vehicle is  
16 completely shut down, or if no low-voltage electrical or pneumatic power is available.

17 The manual emergency operating system shall be operable from inside the carbody and shall consist of  
18 separately activated devices for accomplishing the raising and lowering functions.

19 If specified, means shall be incorporated outside the vehicle for manually releasing and raising the  
20 pantograph from its lock-down position, such as by means of a pole with hook.

#### 21 **4.7.3 Automatic drop down system:**

22 The pantograph shall be fitted with an approved automatic drop down system that is either electrically,  
23 mechanically, or pneumatically activated, as specified. The automatic drop-down system shall cause the  
24 pantograph to be immediately lowered to lock-down height following a failure of the collector head. Drop  
25 time shall not exceed three (3) seconds.

26 Such failures of the collector head shall include, but are not limited to: dislodged contact strips,  
27 entanglement of the collector head with the overhead contact wire or support apparatus, and contact with an  
28 obstruction or other object.

29 The threshold of operation of the automatic drop down system shall be adjustable and shall not result in  
30 nuisance drops where normal in-service operation would activate the system.

31 The automatic drop down system shall not cause any damage to the vehicle, including punching holes in  
32 the vehicle roof, or any additional damage to the pantograph, and no parts or pieces of the pantograph  
33 assembly, other than pieces of the contact strip carbon inserts, shall come loose and fall as a consequence of  
34 its operation.

35 The automatic drop down system shall be resettable with a minimum of effort and with a minimum of parts  
36 renewals. Other than the initial damage caused by the failure of the collector head, any parts that  
37 intentionally fail as a consequence of the operation of the automatic drop down system, such as shear pins

1 or breakaway components, shall be replaceable without a complete disassembly or rebuilding of the  
2 pantograph.

### 3 **4.8 Miscellaneous requirements**

#### 4 **4.8.1 Design life**

5 Pantograph design shall be based on achieving an annual operating mileage of 80 500 km (50 000 miles)  
6 per year.

7 Based on this annual operating mileage, the design life of the pantograph assembly shall be 2 410 000 km  
8 (1 500 000 miles) or 30 years, whichever is greater.

9 The pantograph assembly may include consumables, such as bearings, electrical shunts and seals, which  
10 have a lower design life. The design life of these consumable parts shall be a minimum of 402 350 km  
11 (250 000 miles) or five (5) years, whichever is greater. The collector head contact strips and end horns are  
12 not included in this requirement.

13 Design life shall be demonstrated through calculation and/or operational experience of at least five (5)  
14 years.

#### 15 **4.8.2 Pantograph weight and forces:**

16 The pantograph supplier shall clearly specify the weight of the pantograph.

17 Any vertical and horizontal forces, in addition to the weight of the pantograph, which would be imparted by  
18 the operation of the operating system and automatic drop down system, if supplied, shall be specified by  
19 the pantograph supplier.

#### 20 **4.8.3 Environmental requirements:**

21 The pantograph shall be designed and manufactured to successfully operate in, and shall be protected  
22 against, the environmental conditions expected at the operating authority. Pantographs shall be designed to  
23 operate and be stored in the environments specified in IEEE Std. 1478™-2001 for condition E3, including  
24 protection against corrosion. The temperature, relative humidity, vibration and shock limits shown in Table  
25 1, Condition E3 of IEEE Std. 1478™-2001 are to be replaced by those in Table 7 below.

26 Application specific environmental conditions that prevail at the operating authority are to be obtained in  
27 accordance with Subclause 4 of IEEE Std. 1478™-2001.

1  
2

**Table 7**  
**Environmental Parameter Limits**

Parameter	Condition	Environmental Parameter Limits
Temperature	Operating and Storage	-30°C to +50°C* (-22°F to +122°F)
Relative Humidity	Operating and Storage	5% to 100%
Vibration	Operating	2 m/s <sup>2</sup> (0.2 g)
Mechanical Shock (D = 11ms pulse)	Operating	Longitudinal    50 m/s <sup>2</sup> p (5 g) Vertical            30 m/s <sup>2</sup> p (3 g) Lateral              20 m/s <sup>2</sup> p (2 g)

3

4 The pantograph equipment shall be painted with an approved three-layer (primer and two finish coats) paint  
5 system or an 80 micro-meter (0.003 in) thick powder coating system.

6 Snow shields shall be provided over the operating apparatus and springs on pantographs that will be  
7 operated in snow and freezing rain environments.

#### 8 **4.8.4 Markings:**

9 The pantograph shall include a nameplate riveted to the base frame in a conspicuous position. The  
10 nameplate shall be of stainless steel with 5 mm (0.20-in) raised letters and shall include the following  
11 information as a minimum:

- 12 - Name and address of pantograph supplier
- 13 - Pantograph model number
- 14 - Individual pantograph manufacturer's serial number

15 Permanent "Danger High Voltage" labels shall be affixed to the pantograph in appropriate locations, visible  
16 from both sides of the vehicle.

#### 17 **4.8.5 Frame insulators:**

18 The frame insulators shall electrically isolate the pantograph base frame from the carbody. They shall be  
19 resistant to arc tracking and be of a high-quality and high-strength molded or cast insulating material and  
20 shall be service proven.

21 Frame insulators shall have a minimum dielectric strength of 40 kilovolts dry, a compressive strength of  
22 177.9 kilonewtons (40 000 pounds-force) minimum, and a cantilever strength of 565 newton-meters (5 000  
23 pounds-force-inch) minimum

24 Both ends of the insulator shall include stainless-steel threaded inserts for acceptance of 5/8-11 UNC  
25 threaded fasteners to attach the base frame to the insulator and the insulator to the carbody. Other thread  
26 sizes may be used as approved.

27 The frame insulators shall be designed and tested in accordance with the environmental conditions stated in  
28 4.8.3.

1 The height of the frame insulators shall be specified. The preferred minimum height of the frame insulators  
2 shall be in accordance with Table 8:

3  
4

**Table 8**  
**Frame Insulator Preferred Minimum Heights**

Rated Voltage	Frame Insulator Minimum Height
600/750	60 mm (2.36 in)
1 500	80 mm (3.15 in)
3 000	125 mm (4.92 in)

5 **4.8.6 Electrical clearances:**

6 Distances between the pantograph base frame and any part of the carbody shall not be less than the  
7 minimum frame insulator height.

8 **4.8.7 Electrical connections:**

9 High voltage cable connections to the pantograph connection shall be specified. The preferred connection  
10 shall be by a two-hole crimp-style flat terminal lug on the vehicle primary power cable that attaches to a pad  
11 using bolts, nuts and locking washers. The pad shall be of copper or bronze, silver soldered to a bracket on  
12 the base frame. The pad shall have an area adequate for receiving two (2) two-hole bolted terminals and  
13 shall include mounting holes for the lugs.

14 Low voltage connections with pantograph equipment shall be made with waterproof circular or rectangular  
15 connectors. The connectors shall be sealed on the mating surface and cable entry. The connectors shall  
16 have a metal housing with positive-latching, quick disconnect, watertight connection.

17 Pantographs used for power collection or ice cutting with pneumatic or electric drive motors mounted on  
18 the pantograph base frame, shall be provided with a safety ground connection tab or stud ultimately for  
19 safety ground connection to the carbody.

20 **4.8.8 Other equipment:**

21 Bearings shall be of the high-performance type and sealed against the ingress of water and dust. Bearings  
22 shall be fitted with grease fittings of an approved type. Bearings shall not require the addition of  
23 lubrication at intervals less than those specified in APTA Standard APTA-RT-S-VIM-002-02.

24 Sealed Bearings of the non-lubricated type may be used in the place of bearings with grease fittings,  
25 provided that the pantograph manufacturer guarantees that such bearings, when used in the application,  
26 shall have a design life as required in 4.8.1.

27 Shunts shall be extra-flexible, braided conductors of tinned copper wire, with tinned copper lugs at each  
28 end. The lugs shall be pressure crimped to the braided conductors, and the end of the lug where the  
29 conductors exit shall be flared out to prevent damage to the conductors. The lugs shall be of the two-hole  
30 type with two (2) fasteners to prevent rotation of the lug.

31

1 **4.9 Maintenance requirements**

2 **4.9.1 Maintainability:**

3 The following maintainability requirements shall apply:

4 All bearings shall be easily replaceable and their surfaces shall not form part of a main component.

5 All parts and assemblies shall be capable of being inspected without disassembly or removal of adjacent  
6 parts.

7 All adjustment points and test points shall be fully accessible.

8 The collector head shall be easily removable from the pantograph frame.

9 The contact strips shall be easily removable from the collector head without removal of the collector head  
10 from the pantograph frame.

11 The end horns shall be easily removable from the collector head without removal of the collector head from  
12 the pantograph frame.

13 Maintainability shall be demonstrated through calculation and/or operational experience of at least five (5)  
14 years.

15 **4.9.2 Maintenance requirements:**

16 The pantograph shall be designed and manufactured such that the supplier's maintenance recommendations  
17 are in full accordance with the periodic inspection and maintenance requirements of APTA Standard  
18 APTA-RT-S-VIM-002-02. That standard specifies the maintenance tasks and the frequency of those tasks.  
19 The equipment supplied shall be designed to not require any maintenance action in excess of that specified  
20 therein.

21 The APTA Standard does not specify pantograph assembly overhaul frequencies. In lieu of an APTA  
22 standard, the pantograph overhaul frequency shall be five (5) years

23 **4.9.3 Maintenance and parts documentation:**

24 The supplier shall furnish operation and maintenance and parts manuals that clearly and completely  
25 describe all maintenance and overhaul requirements, with format, content and level of detail in accordance  
26 with the requirements of the customer.

27

## 1 **5. Testing requirements:**

2 The pantograph shall be subjected to a comprehensive test program.

3 There shall be four categories of tests:

- 4 • Qualification Tests
- 5 • Acceptance Tests
- 6 • Investigation Tests
- 7 • Combined Tests.

8 These test categories are described in 5.1 to 5.4. Individual tests are described in 5.8. These  
9 individual tests are grouped by category in Annex D.

10 Excluding combined tests, this standard distinguishes the basic model of a pantograph from the  
11 derived model of the same pantograph. The derived model can incorporate modifications to the  
12 basic design, which shall be considered to be covered by the existing qualification tests, provided  
13 that any such changes can be demonstrated to be at least equal to the basic design through  
14 calculation or operational experience.

15 Supplemental tests in any category shall be conducted if required by the customer.

### 16 **5.1 Qualification tests:**

17 Unless otherwise indicated, qualification tests, also known as “type tests”, shall be performed on  
18 a single pantograph of a given design to prove that the pantograph meets the performance  
19 requirements of this standard or of the customer’s specification.

20 A pantograph configuration in current manufacture shall be considered to have satisfied the  
21 qualification tests, and shall be exempt from them, provided the manufacturer furnishes copies of  
22 signed reports of qualification tests already conducted on identical pantographs that were  
23 previously constructed.

24 Supplementary qualification tests may be required if specified by the customer and agreed to by  
25 the manufacturer.

### 26 **5.2 Acceptance tests:**

27 Acceptance tests, also known as “routine tests” or “production tests”, shall be conducted on each  
28 pantograph to be supplied to the customer to verify that the properties of production pantographs  
29 correspond to those measured during the qualification test.

30 For certain equipment, after agreement between customer and supplier, acceptance tests may be  
31 replaced by sampling tests (tests performed on a selected number of apparatus taken at random  
32 from a batch).

33

**1 5.3 Investigation tests:**

2 Investigation tests are supplementary and special tests, which are to be performed on a single  
3 pantograph in order to obtain additional information. Investigation tests shall be conducted only if  
4 they are expressly specified by the customer. Investigation tests may also be requested  
5 subsequent to the procurement to assess in-service problems or failures.

**6 5.4 Combined tests:**

7 Combined tests are special and supplementary tests which are performed in an operating  
8 environment using the track and/or overhead line system defined in the customer's specifications.  
9 They shall take into account the type of vehicle to be used, train consist, speed, and direction of  
10 travel.

11 Combined tests shall be conducted only if they have been specified by the customer. Combined  
12 tests may be requested subsequent to the procurement to investigate in-service problems or  
13 failures.

**14 5.5 Test configuration:**

15 Unless otherwise specified, pantographs subjected to these tests shall be fully assembled and  
16 complete in every respect. They shall include all required mechanical and electrical components,  
17 and shall be in full operational condition.

**18 5.6 Test and measuring equipment:**

19 All test and measuring equipment used in these tests shall be appropriate for the task at hand  
20 and shall be in current calibration, which calibration shall be traceable to the Canadian Standards  
21 Association, the United States National Institute of Science and Technology, or other specification  
22 as applicable. The test and measuring equipment shall have the accuracy necessary for  
23 determining conformance of the parameter being measured, with tolerances, with approved  
24 drawings and other operational data. In no case shall the accuracy of measurement be less than  
25  $\pm 1$ -percent.

**26 5.7 Test procedures and reports:**

27 A detailed procedure for each category of tests and a final report of the test results shall be  
28 prepared by the supplier and submitted to the customer for review and approval.

29 For expediency, tests may be combined as agreed between the supplier and customer.

**30 5.8 Individual tests**

31 Any deviations from these requirements shall be negotiated between the supplier and the  
32 customer.

1 **5.8.1 Visual inspection:**

2 **5.8.1.1. Purpose**

3 The purpose of this test is to ensure that the pantograph is free from physical defects.

4 **5.8.1.2 Procedure**

5 The pantograph shall be given a thorough visual examination.

6 **5.8.1.3 Test Acceptance Criteria**

7 The pantograph shall be free from physical defects. Markings shall comply with the requirements  
8 of 4.8.4.

9 **5.8.2 Weight:**

10 **5.8.2.1 Purpose**

11 The purpose of this test is to determine the weight of the pantograph.

12 **5.8.2.2 Procedure**

13 The pantograph shall be weighed by a suitable means. The pantograph shall be in a completely  
14 assembled and ready-to-run condition, with all components and parts included.

15 **5.8.2.3 Test acceptance criteria**

16 The weight of the pantograph shall comply with the contractual weight as specified in 4.8.2 and  
17 shall be within the tolerance limits agreed between the supplier and the customer.

18 **5.8.3 Dimensions:**

19 **5.8.3.1 Purpose**

20 The purpose of this test is to ascertain that the pantograph meets the dimensional requirements  
21 of the outline drawing of the pantograph that has been reviewed and approved by the customer.

22 **5.8.3.2 Procedure**

23 The dimensions of the pantograph shall be measured using appropriate measuring equipment.  
24 Each of the dimensions shown in Figure A.1 of Annex A and defined in 3.3, and as specified on  
25 the drawing, shall be verified.

1 **5.8.3.3 Test acceptance criteria**

2 The dimensions shall conform to the dimensions, with tolerances, specified on the customer  
3 approved drawings.

4 **5.8.4 Automatic drop down system functional test:**

5 **5.8.4.1 Purpose**

6 The purpose of this test is to demonstrate acceptable functioning of the Automatic Drop Down  
7 System.

8 **5.8.4.2 Procedure**

9 The functioning of the Automatic Drop Down System shall be tested by raising the pantograph  
10 and activating the system by the simulation of damage to the collector head at the maximum  
11 operating speed of the vehicle. Special attention shall be made to the measurement of the drop  
12 time and the sensitivity of the automatic drop down system to nuisance trips.

13 The test shall be performed at the following two (2) pantograph heights:

- 14
- At Maximum Working Height (HMAX)
  - At a height 20-percent of the Working Range (WR) above the Minimum Working Height (HMIN), which shall be calculated by the formula  $(HMIN + 0.2 \times WR)$ .
- 15
- 16

17 Following the test, the pantograph shall be thoroughly disassembled and all parts carefully  
18 examined.

19 Simulated static testing of the Automatic Drop Down system shall be conducted as acceptance  
20 tests.

21 **5.8.4.3 Test acceptance criteria**

22 The Automatic Drop Down System shall react and operate as specified in 4.7.3 and no additional  
23 damage shall occur to the pantograph beyond those items which react to the operation of the  
24 automatic drop down system, such as failure of shear pins or frangible welded joints.

25 **5.8.5 Operating tests – ambient conditions:**

26 **5.8.5.1 Purpose**

27 The purpose of this test is to demonstrate that the pantograph raises and lowers in the times and  
28 at the ambient temperature specified.

1 **5.8.5.2 Procedure**

2 The pantograph shall be functionally tested at the nominal ambient temperature and at the rated  
3 voltage of the electrical operating system and/or at the rated air pressure. This test can be  
4 conducted either in a laboratory or on a vehicle.

5 **5.8.5.3 Test acceptance criteria**

6 The pantograph shall rise from lock-down height to the maximum working height in a smooth and  
7 steady manner, and shall softly contact the overhead wire without any impact or significant  
8 rebound that is injurious to the contact strip or to the overhead contact wire.

9 The pantograph shall rise from lock-down height to the maximum working height in the time  
10 specified in 4.7.1.1.

11 The pantograph shall be lowered from the maximum working height to lock-down in the time  
12 specified in 4.7.1.1.

13 **5.8.6 Operating tests – extreme climatic conditions:**

14 **5.8.6.1 Purpose**

15 The purpose of this test is to demonstrate that the pantograph raises and lowers in the times and  
16 at the temperature and humidity extremes specified.

17 **5.8.6.2 Procedure**

18 The pantograph shall be functionally tested at the extremes of temperature and humidity as  
19 specified in 4.8.3.

20 The tests shall be conducted at each of the minimum and maximum temperatures and, where  
21 pneumatic equipment is fitted, at each of the maximum and minimum air pressures for which the  
22 supplier guarantees operation, and at the operating voltage extremes specified. The tests shall  
23 **be repeated sufficient times to assure repeatability, but not less than three (3)**  
24 **times.**

25 **5.8.6.3 Test acceptance criteria**

26 The pantograph shall rise from lock-down height to the maximum working height in a smooth and  
27 steady manner, and shall softly contact the overhead wire without any impact and or significant  
28 rebound that is injurious to the contact strip or to the overhead contact wire.

29 The pantograph shall rise from lock-down height to the maximum working height in the time  
30 specified in 4.7.1.1.

31 The pantograph shall be lowered from the maximum working height to lock-down in the time  
32 specified in 4.7.1.1.

1 **5.8.7 Mechanical endurance tests:**

2 **5.8.7.1 Purpose**

3 The purpose of this test is to determine that the pantograph will endure 10,000 successive raising  
4 and lowering cycles without abnormal wear or damage, or activation of the Automatic Drop Down  
5 System.

6 **5.8.7.2 Procedure**

7 A fully assembled and operational pantograph, including all electrical and mechanical  
8 components and apparatus, complete in all respects, shall be subjected to 10 000 successive  
9 raising and lowering operations, from the lock-down height (HL) to the maximum working height  
10 (HMAX).

11 The mechanical endurance testing shall be conducted at ambient temperature and at the rated  
12 voltage of the electrical operating system and at the rated air pressure, where pneumatic  
13 equipment is fitted, or both if a combined electrical and pneumatic operating system is used..

14 During the first 500 and the last 500 raising and lowering operations, the pantograph shall be  
15 raised to the Maximum Extended Height (HME) with the operating system air supply pressure  
16 and/or operating system voltage at the minimum values for which the supplier guarantees  
17 operation.

18 During the second 500 raising and lowering operations (501st to 1 000th cycle), the pantograph  
19 shall be raised to the Maximum Extended Height (HME) at the minimum operating temperature  
20 and with the operating system air supply pressure and/or operating system voltage at the  
21 minimum values for which the supplier guarantees operation.

22 During the next to last 500 raising and lowering operations (9 000th to 9 500th cycle), the  
23 pantograph shall be raised to the Maximum Extended Height (HME) at the maximum operating  
24 temperature and with the operating system air supply pressure and/or the operating system  
25 voltage at the minimum values for which the supplier guarantees operation.

26 Means shall be employed to exercise the collector head through each of its degrees of freedom to  
27 its fullest extent during each raising and lowering cycle.

28 **5.8.7.3 Test acceptance criteria**

29 After the test, all parameters shall be adjusted to the nominal values and the pantograph shall  
30 meet the Operating Test acceptance criteria of 5.8.5.

31 There shall be no abnormality observed in either the operation of the pantograph or in the raising  
32 and lowering times

33 There shall not be any abnormal wear in any of the pantograph parts or components.

34 There shall be no distortions or fractures in any of the pantograph parts or components.

1 **5.8.8 Resonant frequency search:**

2 **5.8.8.1 Purpose**

3 The purpose of this test is to identify resonant frequencies of the pantograph and to vibrate the  
4 assembly at those resonant frequencies to assure that there will be no degradation of the  
5 pantograph.

6 **5.8.8.2 Procedure**

7 The resonant frequencies of the pantograph in the vertical, longitudinal and transverse directions  
8 shall be determined by testing.

9 The pantograph, fitted with a collector head that has the largest mass designed for the  
10 pantograph, shall be installed with its frame insulators on a vibrating shake table. The shake  
11 table shall produce sinusoidal vibrations, with adjustable amplitude and frequency.

12 The pantograph shall be extended to its Maximum Extended Height (HME). The frequency shall  
13 be progressively varied from 1 Hz to 50 Hz for at least four (4) minutes. The oscillation amplitude  
14 in millimeters shall be determined by the following formulae:

15  $a = 25/f$  for  $1 \text{ Hz} \leq f \leq 10 \text{ Hz}$  (4)

16  $a = 250/f$  for  $10 \text{ Hz} \leq f \leq 100 \text{ Hz}$  (5)

17

18 where

19  $f$  = frequency

20  $a$  = amplitude

21 The test shall be carried out successively in each of the three principal directions: vertical,  
22 longitudinal and transverse.

23 If any resonant frequency is found during the search, the pantograph assembly shall be vibrated  
24 at each of the resonant frequencies and at the corresponding amplitudes. The vibration shall be  
25 maintained for at least ten (10) minutes at each resonant frequency.

26 **5.8.8.3 Test acceptance criteria**

27 After the test, all parameters shall be adjusted to the nominal values and the pantograph shall  
28 meet the Operating Test acceptance criteria of 5.8.5.

29 There shall be no abnormality observed in either the operation of the pantograph or in the raising  
30 and lowering times

31 There shall not be any abnormal wear in any of the pantograph parts or components.

1 There shall be no distortions or fractures in any of the pantograph parts or components.

2 **5.8.9 Transverse vibration withstand test:**

3 **5.8.9.1 Purpose**

4 The purpose of this test is to assure that the pantograph can sustain transverse vibrations without  
5 damage.

6 **5.8.9.2 Procedure**

7 The pantograph, fitted with a collector head that has the largest mass designed for the  
8 pantograph, shall be installed with its frame insulators on a vibrating shake table. The shake  
9 table shall produce sinusoidal vibrations, with adjustable amplitude and frequency.

10 The pantograph shall be extended to its Maximum Extended Height (HME).

11 The pantograph shall be vibrated in the transverse direction for  $10^7$  (10 000 000) cycles. The  
12 frequency of vibration shall be ten (10) percent lower than the transverse resonant frequency  
13 found in the 5.8.8. If more than one (1) transverse resonant frequency was found, the test shall  
14 be repeated in the same manner for each frequency. If no resonant frequency was found, this  
15 test shall be performed at 10 Hz. The amplitude of vibration shall be calculated in accordance  
16 with the formulae in 5.8.8.

17 **5.8.9.3 Test acceptance criteria**

18 After the test, all parameters shall be adjusted to the nominal values and the pantograph shall  
19 meet the Operating Test acceptance criteria of 5.8.5.

20 There shall be no abnormality observed in either the operation of the pantograph or in the raising  
21 and lowering times

22 There shall not be any abnormal wear in any of the pantograph parts or components.

23 There shall be no distortions or fractures in any of the pantograph parts or components.

24 **5.8.10 Shock withstand test:**

25 **5.8.10.1 Purpose**

26 The purpose of this test is to determine that the pantograph can withstand without damage  
27 longitudinal shocks applied to the base of the frame insulators and transverse shocks applied to  
28 the collector head pivot.

1 **5.8.10.2 Procedure**

2 The pantograph, fitted with a collector head that has the largest mass designed for the  
3 pantograph, shall be installed with its frame insulators in a shock testing device. The shock  
4 testing device shall produce sinusoidal shock pulses with adjustable amplitude.

5 The pantograph shall be extended to its Maximum Extended Height (HME).

6 The pantograph shall be subjected to a series of three (3) successive shock pulses of magnitude  
7 30 meters per second (3g) in amplitude applied longitudinally at the base of the insulators.

8 Following that test, the pantograph shall be subjected to a series of three (3) successive shock  
9 pulses of magnitude 30 meters/sec<sup>2</sup> (3g) in amplitude applied transversely to the collector head  
10 pivot.

11 **5.8.10.3 Test acceptance criteria**

12 After the test, all parameters shall be adjusted to the nominal values and the pantograph shall  
13 meet the Operating test acceptance criteria of 5.8.5.

14 There shall be no abnormality observed in either the operation of the pantograph or in the raising  
15 and lowering times.

16 There shall not be any abnormal wear in any of the pantograph parts or components.

17 There shall be no distortions or fractures in any of the pantograph parts or components.

18 **5.8.11 Transverse rigidity test:**

19 **5.8.11.1 Purpose**

20 The purpose of this test is to determine that the pantograph meets the transverse rigidity  
21 requirements of 4.6.4.

22 **5.8.11.2 Procedure**

23 The pantograph shall be extended to its Maximum Extended Height (HME).

24 A transverse force of 300 newtons (67.5 pounds-force) shall be applied successively on each  
25 side of the part of the pantograph frame which supports the collector head and the displacement  
26 shall be measured.

27 **5.8.11.3 Test acceptance criteria**

28 The displacement shall be symmetrical and in accordance with the requirements of 4.6.4.

29 After the test, all parameters shall be adjusted to the nominal values and the pantograph shall  
30 meet the Operating Test acceptance criteria of 5.8.5.

1 There shall be no abnormality observed in either the operation of the pantograph or in the raising  
2 and lowering times

3 There shall not be any abnormal wear in any of the pantograph parts or components.

4 There shall be no distortions or fractures in any of the pantograph parts or components.

5 **3.5.1 5.8.12 Air tightness test – ambient conditions:**

6 **5.8.12.1 Purpose**

7 The purpose of this test is to assure that the pneumatic components of the pantograph, if used,  
8 are tight and do not leak.

9 **5.8.12.2 Procedure**

10 Any pneumatic components used in the operating system shall be tested to ensure that they are  
11 sealed against leakage.

12 This test shall be carried out at ambient temperature.

13 The pneumatic components shall be tested at the maximum or minimum operating pressure,  
14 whichever is more severe. The test air supply shall conform to the requirements of 4.7.1.

15 If the operating system includes any magnet valves, it shall be tested with the valves energized.  
16 The valve coil(s) shall be energized with a current equal to that obtained with the winding hot and  
17 at the minimum allowed operating voltage.

18 The pneumatic equipment shall be connected to a tank whose volume is the same as the total  
19 volume of all tubing, piping, air cylinders and bellows used in the operating system, but in no case  
20 shall the volume be less than one (1) liter (61.0 cubic inches).

21 The tank shall be pressurized for ten (10) minutes at the test pressure.

22 **5.8.12.3 Test acceptance criteria**

23 The pressure in the tank shall not decrease by more than three (3) percent of the initial pressure  
24 after ten (10) minutes on the test.

25 **5.8.13 Air tightness test – extreme climatic conditions:**

26 **5.8.13.1 Purpose**

27 The purpose of this test is to assure that the pneumatic components of the pantograph, if used,  
28 are tight and do not leak at temperature extremes.

1 **5.8.13.2 Procedure**

2 All pneumatic components used in the operating system shall be tested at the extremes of  
3 temperature as specified in 4.8.3, to ensure that the pneumatic components are sealed against  
4 leakage.

5 The test at each temperature extreme shall be conducted at each of the maximum and minimum  
6 air pressures defined in 4.7.1.

7 If the operating system includes any magnet valves, it shall be tested with the valve coil(s)  
8 energized with a current equal to that obtained with the winding hot and at the minimum allowed  
9 operating voltage.

10 The pneumatic equipment is to be connected as specified in 5.8.132 and pressurized at the test  
11 pressures for a minimum of ten (10) minutes.

12 **5.8.13.3 Test acceptance criteria**

13 The pressure in the tank shall not decrease by more than three (3) percent of the initial pressure  
14 after ten (10) minutes on the test.

15 **5.8.14 Measurement of degrees of freedom of collector head:**

16 **5.8.14.1 Purpose**

17 The purpose of this test is to determine that the degrees of freedom of the collector head are in  
18 compliance with the requirements of 4.5.8.

19 **5.8.14.2 Procedure**

20 The ranges of travel and rotation of the collector head about the pitch, roll and yaw axes of the  
21 collector head shall be measured at the Minimum Working Height (HMIN) and at the Maximum  
22 Working Height (HMAX).

23 **5.8.14.3 Test acceptance criteria**

24 The degrees of freedom and the amount of rotation or movement about each axis shall be in full  
25 accordance with the requirements of 4.5.8.

26 The movement and rotation of the collector head shall be steady and smooth. There shall be no  
27 stiffness or binding.

28 **5.8.15 Measurement of retaining force in lock down position:**

29 **5.8.15.1 Purpose**

30 The purpose of this test is to determine the force required to move the pantograph from the  
31 locked down position, if a method other than a positive mechanical latch is employed.

1 **5.8.15.2 Procedure**

2 The pantograph shall be placed in its locked down position and the force required to move the  
3 pantograph out of the locked down position shall be measured by means of an instrument fixed to  
4 the collector head through which a vertical force is exerted.

5 **5.8.15.3 Test acceptance criteria**

6 The value of force required to move the collector head from its locked down position shall not  
7 exceed the value specified in 4.6.5.

8 **5.8.16 Measurement of static force (qualification test):**

9 **5.8.16.1 Purpose**

10 The purpose of this test is to determine that the vertical force with the pantograph raising and  
11 lowering is in compliance with the requirements of 4.6.2 when raising and lowering at the  
12 maximum permissible frame vertical speed.

13 **5.8.16.2 Procedure**

14 The pantograph shall be complete and in a ready-to-run configuration and condition. If a damper  
15 is included as part of the pantograph, it shall be disconnected during this test.

16 The vertical force shall be measured vertically downward and directly under the collector head at  
17 the centerline of the collector head by a suitable device during the raising and lowering of the  
18 pantograph. The test shall first be performed at a slow “creeping speed” where the raising and  
19 lowering speed is set at 0.05 meters per second (2 inches per second) with a tolerance of  $\pm 10$   
20 percent.

21 If these “creeping speeds” are unattainable, then this portion of the test may be conducted at the  
22 normal raising and lowering speeds of 4.7.1.1.

23 Following that test, the test shall be performed again, but the raising and lowering speed shall be  
24 at the maximum permissible pantograph frame vertical speed as specified in 4.6.6, with a  
25 tolerance of  $\pm 10$  percent.

26 The static force shall be recorded at the various heights specified in 4.6.2 without stopping the  
27 raising or lowering movements, which shall be carried out in a continuous manner for three (3)  
28 complete cycles.

29 If it is not possible to attain the maximum permissible pantograph frame vertical speed in the  
30 laboratory, then this test may be performed on an operating railway or test track with the test  
31 pantograph mounted on a vehicle and where the overhead wire gradient and vehicle speed is set  
32 to replicate this speed.

33 NOTE - The speed at which this test is conducted is the maximum permissible pantograph frame vertical  
34 speed as specified in 4.6.6. Neither it nor the creeping speed are related to the raising and lowering speeds  
35 of the pantograph specified in 4.7.1.

1 **5.8.16.3 Test acceptance criteria**

2 The measured static forces of each test shall comply with the requirements of 4.6.2.

3 **5.8.17 Measurement of static force (acceptance test):**

4 **5.8.17.1 Purpose**

5 The purpose of this test is to determine that the vertical force with the pantograph raising and  
6 lowering is in compliance with the requirements of 4.6.2.

7 **5.8.17.2 Procedure**

8 The pantograph shall be complete and in a ready-to-run configuration and condition. If a damper  
9 is included as part of the pantograph, it shall not be disconnected during this test.

10 The nominal static force shall be measured vertically downward and directly under the collector  
11 head at the centerline of the collector head by a suitable device during the raising and lowering of  
12 the pantograph. The speed of raising and lowering during the conduct of this test shall be in  
13 accordance with the requirements of 4.7.1.1

14 The vertical force shall be recorded at the various heights specified in 4.6.2 without stopping the  
15 raising or lowering movements, which shall be carried out in a continuous manner for three (3)  
16 complete cycles.

17 **5.8.17.3 Test acceptance criteria**

18 The measured vertical forces shall comply with the requirements of 4.6.2.

19 **5.8.18 Measurement of total force:**

20 **5.8.18.1 Purpose**

21 The purpose of this test is to determine that the total force is in accordance with the requirements  
22 of 4.6.3.

23 **5.8.18.2 Procedure**

24 The total force produced as a result of the aerodynamic air flow at the vehicle operating speed  
25 shall be measured.

26 The total force shall be measured using a measuring instrument attached to the collector head  
27 such that the airflow, produced either in a wind tunnel or by the vehicle in operation, acts in a  
28 longitudinal direction in relation to the vehicle. In the latter case, the pantograph shall be held  
29 away from the contact wire in a suitable manner to facilitate force measurement.

30 The test shall be carried out in both directions of travel.

1 **5.8.18.3 Test acceptance criteria**

2 The measured total force shall comply with the requirements of 4.6.3.

3 **5.8.19 Rated and maximum current heating tests (vehicle at standstill):**

4 **5.8.19.1 Purpose**

5 The purpose of these tests is to establish that the pantograph will carry the rated and maximum  
6 currents, with the vehicle at standstill, without damage,

7 **5.8.19.2 Procedure**

8 The pantograph shall be connected to a direct-current power supply and electric circuit capable of  
9 supplying for one hour (60 minutes) a current equal to the rated current, vehicle at standstill, as  
10 defined in 3.4.3 and then, immediately thereafter, of supplying for 1-1/2 minutes (90 seconds), a  
11 current equal to the maximum current, vehicle at standstill, as defined in 3.4.4.

12 These tests shall be conducted in a laboratory and on a pantograph at standstill.

13 The current shall be supplied to the pantograph at its minimum working height (HMIN) through a  
14 longitudinally oriented conductor contacting the contact strips evenly with a contact pressure  
15 equal to the nominal static force.

16 The conductor shall withstand the test currents, and the force between the contact strips and the  
17 conductor shall be the nominal static force as specified in 4.6.2.

18 During the test, the temperature in the contact strips shall be measured against time in two (2)  
19 places. The first measurement point should be as close as possible to the point of contact with  
20 the conductor. The second measurement point should be as close as possible to the interface of  
21 the contact strip material and the carrier.

22 All joints in the pantograph shall be disassembled following the tests and all parts shall be  
23 examined.

24 **5.8.19.3 Test acceptance criteria**

25 There shall be no signs of deformation or abnormal heating on any part of the pantograph  
26 including the electrical shunts and the contact strips.

27 There shall be no damage to bearings, pivots and shunts due to the passage of current.

28 The temperature in the contact strips at any point shall not exceed 75 percent of the maximum  
29 allowable operating temperature as defined by the manufacturer of the contact strips.

30 NOTE- Generally the temperature of bonded contact strips should be limited to 210°C (410°F). The temperature of  
31 soldered contact strips should be limited to 180°C (356°F).

1 **5.8.20 Rated and maximum current heating tests (vehicle running):**

2 **5.8.20.1 Purpose**

3 The purpose of these tests is to establish that the pantograph will carry the rated and maximum  
4 currents without damage with the vehicle running.

5 The pantograph shall be subjected to a heating test for 30 minutes at the rated current of the  
6 vehicle running as specified in 3.4.5, and immediately following that test, a heating test for 30  
7 seconds at the maximum current as specified in 3.4.4.

8 **5.8.20.2 Procedure**

9 It is preferred that these tests be conducted on a pantograph mounted on a vehicle and running  
10 at a speed at which the maximum heating would occur. However, if that is not feasible, this test  
11 may be conducted in a laboratory. Electrical loads shall be incorporated on the vehicle as  
12 needed to attain the required currents.

13 NOTE - To ensure that constant currents as required are obtained for the required time, it may be necessary  
14 to mount the pantograph on a work vehicle or test vehicle, with a resistor bank for simulating the required  
15 loads, with resistive loads switched in and out as needed by contactors.

16 During the test, values of current and temperature against time shall be recorded in critical  
17 sections of the contact strips as mutually agreed by the customer and supplier.

18 All joints in the pantograph shall be disassembled following the tests and all parts shall be  
19 examined.

20 **5.8.20.3 Test acceptance criteria**

21 There shall be no signs of deformation or abnormal heating on any part of the pantograph  
22 including the contact strips.

23 There shall be no damage to bearings, pivots and shunts due to the passage of current.

24 The temperature in the contact strips shall not exceed 75 percent of the maximum allowable  
25 operating temperature as defined by the manufacturer of the contact strips.

26 **5.8.21 Insulation and dielectric tests:**

27 **5.8.21.1 Purpose**

28 The purpose of this test is to verify the state of the electrical insulation used in electrical wiring and  
29 cabling, including frame insulators.

30 **5.8.21.2 Procedure**

31 Each pantograph shall be subjected to insulation resistance and dielectric tests carried out  
32 according to the requirements of 5.9 of IEEE Std. 16™-2004.

1 **5.8.21.3 Test acceptance criteria**

2 The requirements of 5.9 of IEEE Std. 16™-2004 shall be met.

3 **5.8.22 Dynamic operational test:**

4 **5.8.22.1 Purpose**

5 The purpose of this test is to check the proper operation of the pantograph on a vehicle or a train  
6 of vehicles on the system where the vehicle is to operate.

7 **5.8.22.2 Procedure**

8 The quality of the overhead contact wire and power supply system, under which the tests shall be  
9 conducted, shall be specified.

10 The vehicle shall be operated at the maximum vehicle speed. If multiple vehicle operation is  
11 specified or intended by the operating authority, then separate tests shall be conducted with a  
12 multiple-unit vehicle consist with all the pantographs on the train raised and operable. The  
13 vehicles shall be coupled and oriented to result in the shortest distance between pantographs to  
14 evaluate dynamic coupling between pantographs.

15 NOTE – This test is to be conducted to evaluate the coupling of pantograph dynamic motion through the overhead  
16 contact wire.

17 The weather at the time of the test shall be noted.

18 A test shall be conducted to ensure that satisfactory current collection takes place, without  
19 damage or abnormal wear to either the pantograph or to the overhead contact wire and  
20 associated parts.

21 The electrical and mechanical operation of the pantograph through cross-overs, wire crossings,  
22 section insulators and overlaps in the overhead contact system shall be checked.

23 A test shall be conducted in both directions of travel with the pantograph raised, at speeds up to  
24 the maximum vehicle speed, to ensure that the aerodynamic effect does not cause forces which,  
25 in addition to the static forces, exceed the requirements of 4.6.3. This test shall be repeated with  
26 vehicles in multiple consist, if multiple vehicle operation is specified.

27 A test shall also be conducted to ensure that the aerodynamic effect does not produce an  
28 unauthorized raising of a lowered pantograph and has no adverse influence on the proper  
29 execution of raising or lowering movements at speed.

30 **5.8.22.3 Test acceptance criteria**

31 The pantograph shall operate successfully over the lines of the operating authority as intended  
32 and without any undesirable bounce or other adverse effects.

1 **5.8.23 Pantograph tracking test:**

2 **5.8.23.1 Purpose**

3 The purpose of this test is to confirm that the vehicle can draw the rated and peak currents  
4 without the loss of contact with the overhead contact wire with the pantograph traversing the  
5 maximum specified contact wire gradient, while maintaining the nominal contact force defined in  
6 4.6.2 and determined in 5.8.16.

7 **5.8.23.2 Procedure**

8 Alternate procedures that comply with the intent of these tests may be considered by the  
9 customer.

10 These tests shall be conducted by the operating authority with a pantograph mounted on a  
11 service vehicle. A test section of straight tangent track shall be selected where operating speeds  
12 can be maintained at up to 48 kilometers per hour (30 miles per hour). The overhead contact  
13 wire in the test location shall be temporarily modified to a two (2) percent rising gradient over a  
14 minimum distance of 60 meters (200 feet).

15 It is necessary that the pantograph tracking be tested for both a rising gradient and a falling  
16 gradient. If the vehicle cannot be operated at the required speeds in both directions, it would be  
17 necessary to install a rising gradient and then a falling gradient in the test area in the direction of  
18 traffic.

19 Electrical loads shall be incorporated on the vehicle as needed to attain the rated current, vehicle  
20 running of 3.4.5. The current being collected from the overhead contact wire shall be measured  
21 and recorded as close to the collector head as possible without affecting the dynamic  
22 performance of the collector head. An oscillograph recorder with a suitable frequency response  
23 shall be used for recording the current and detecting any short duration loss of contact.

24 The dynamic force of the pantograph contact strips on the overhead contact wire shall be  
25 measured and recorded using a measuring instrument attached to the collector head.

26 The vehicle shall be operated into the rising gradient at speeds increasing in 8 km/hr (5 mph)  
27 increments until the pantograph contact strips start to lose contact with the overhead contact wire  
28 or until the maximum speed is attained. Two additional data points shall be taken beyond the  
29 point of instability.

30 The test shall be run three (3) times and the results averaged. The test shall then be run in the  
31 opposite direction to simulate response to a falling gradient, or into a test section with a falling  
32 gradient.

33 **5.8.23.3 Test acceptance criteria**

34 The dynamic force shall comply with the requirements of 4.6.3 up to the point where the  
35 pantograph frame maximum vertical speed is reached. In addition, there shall be no discernable  
36 loss of contact or no discernable interruptions of current being collected up to that speed.

37 Any interruptions of current shall be less than the minimum threshold where a loss of traction  
38 power would initiate a shutdown or any pause in the operation of vehicle equipment and  
39 apparatus, or would initiate the operation of protective devices.

40 The pantograph frame maximum vertical speed is to be calculated from the tests and shall meet  
41 the requirements of 4.6.6.

**Annex A**  
 (informative)  
**Single arm pantograph terminology and components**

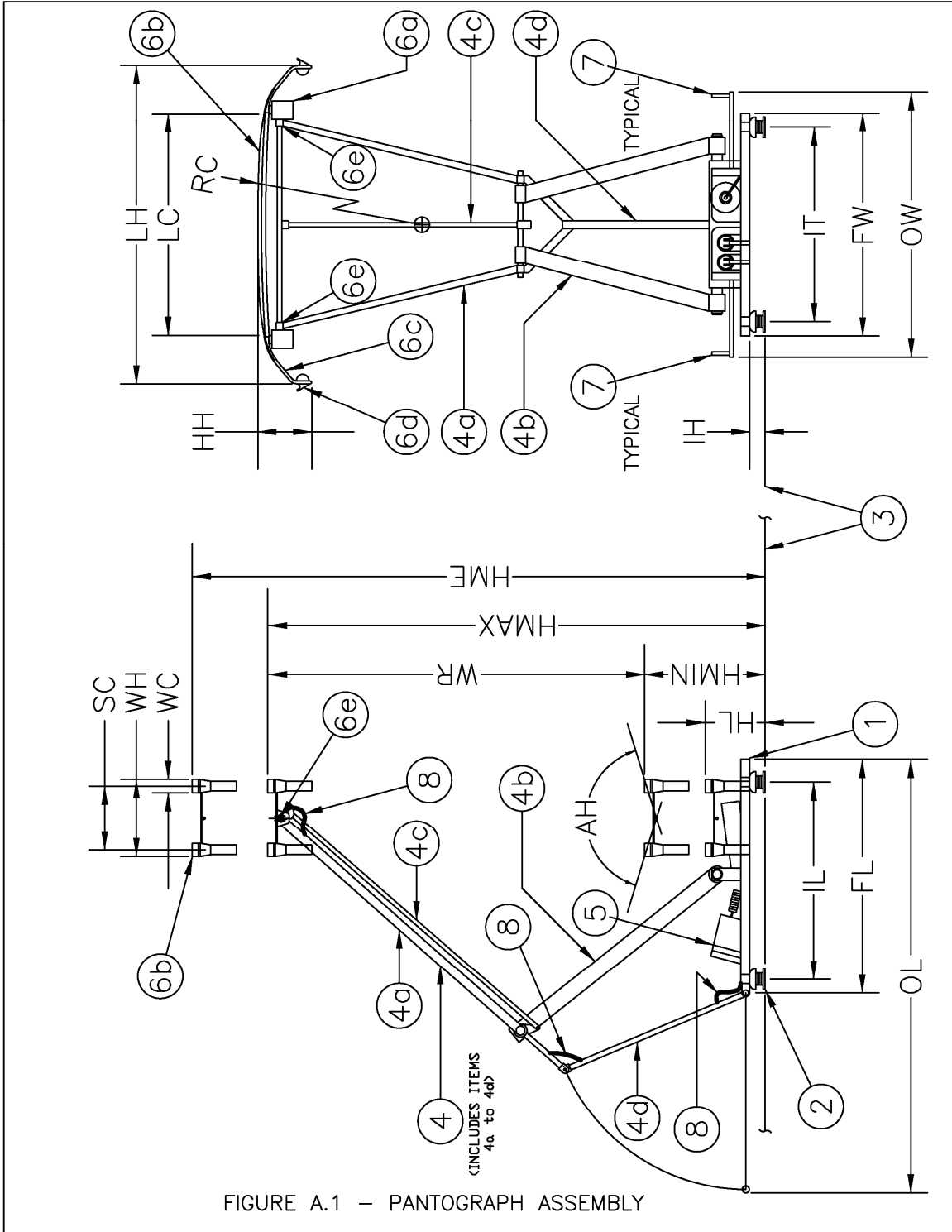

FIGURE A.1 – PANTOGRAPH ASSEMBLY

<b>Pantograph Terminology (Reference Figure A.1)</b>			
<b>Dimension.</b>	<b>Definition</b>	<b>Reference</b>	<b>Requirement</b>
AH	Collector Head Angle	3.3.3	4.5.3
FL	Base Frame Length	3.3.1	4.3
FW	Base Frame Width	3.3.2	4.3
HH	Height of Collector Head Height	3.3.5	4.5.7
HL	Lock-Down Height	3.3.11	4.4
HMAX	Maximum Working Height	3.3.13	4.4
HME	Maximum Extended Height	3.3.12	4.4
HMIN	Minimum Working Height	3.3.14	4.4
IH	Insulator Height	3.3.6	4.3
IL	Insulator Mounting Spacing - Longitudinal	3.3.7	4.3
IT	Insulator Mounting Spacing - Transverse	3.3.8	4.3
LC	Length of Contact Strip	3.3.10	4.5.4
LH	Length of Collector Head	3.3.9	4.5.1
OL	Overall Length	3.3.15	4.3
OW	Overall Width	3.3.16	4.3
RC	Radius of Contact Strip	3.3.17	4.5.4
SC	Distance Between Contact Strips	3.3.4	4.5.2
WC	Width of Contact Strip	3.3.19	4.5.4
WH	Width of Collector Head	3.3.18	4.5.2
WR	Working Range (HMAX – HMIN)	3.3.20	4.4

<b>Pantograph Components (Reference Figure A.1)</b>		
<b>Item No.</b>	<b>Definition</b>	<b>Reference</b>
1	Base Frame	3.2.2.1
2	Frame Insulators	3.2.2.2
3	Pantograph Mounting Plane	3.2.2.3
4	Pantograph Frame Assembly	3.2.2.4
4a	Upper Strut (Upper Frame)	
4b	Lower Strut (Lower Frame)	
4c	Upper Guide Rod (Collector Head and Pan-Guide)	
4d	Lower Guide Rod (Coupling Rod)	
5	Primary Suspension	3.2.2.5
6a	Secondary Suspension	3.2.2.6(a)
6b	Contact Strip	3.2.2.6(b)
6c	End Horn	3.2.2.6(c)
6d	End Horn Hook	3.2.2.6(d)
6e	Collector Head Pivot	3.2.2.6(e)
7	Manual Emergency Operating System	3.2.2.7
8	Electrical Shunts	3.2.2.8

## Annex B (informative) Two-Arm and Four-Arm Diamond Type

### Pantographs

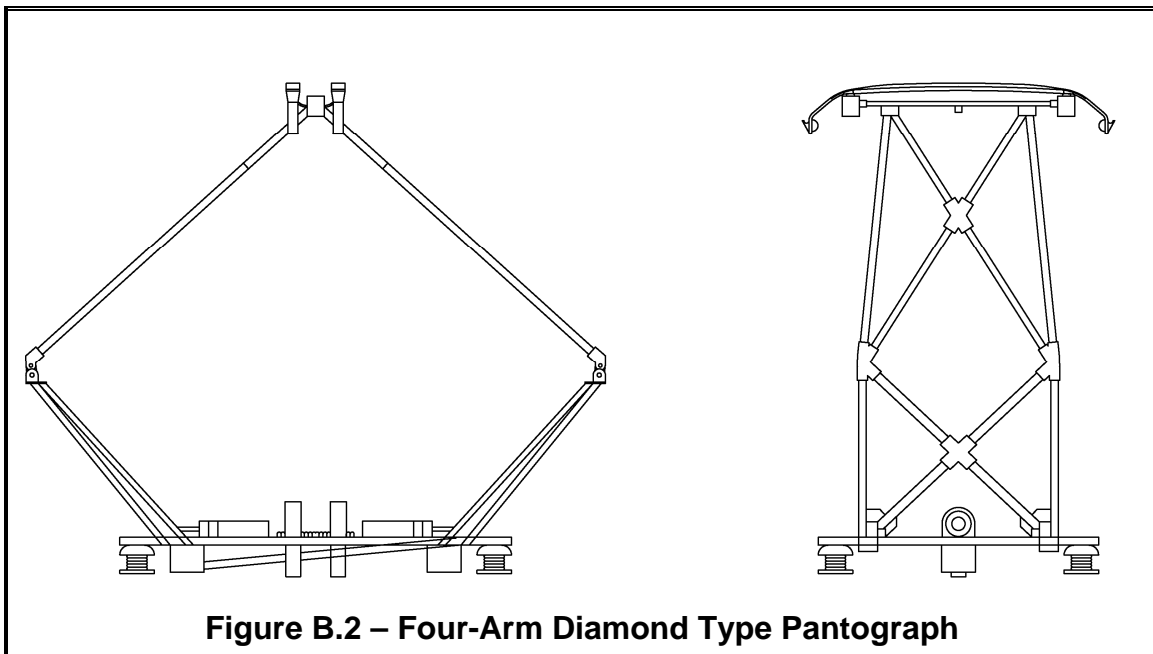
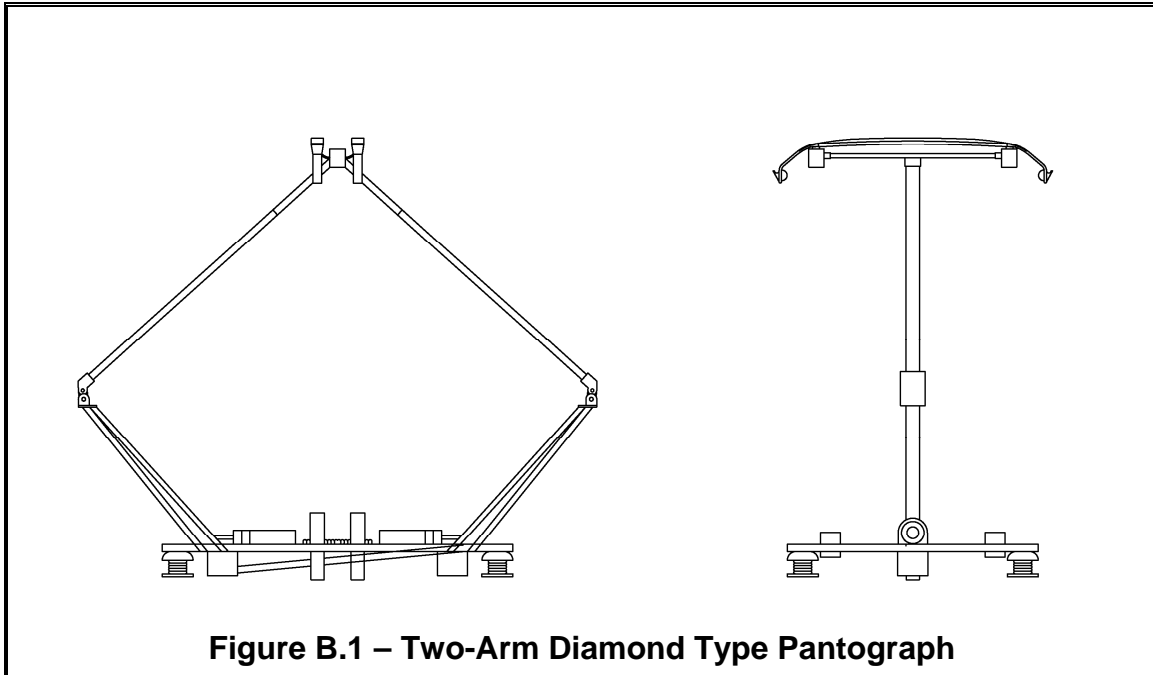

Annex C (normative) Pantograph collector head preferred dimensions

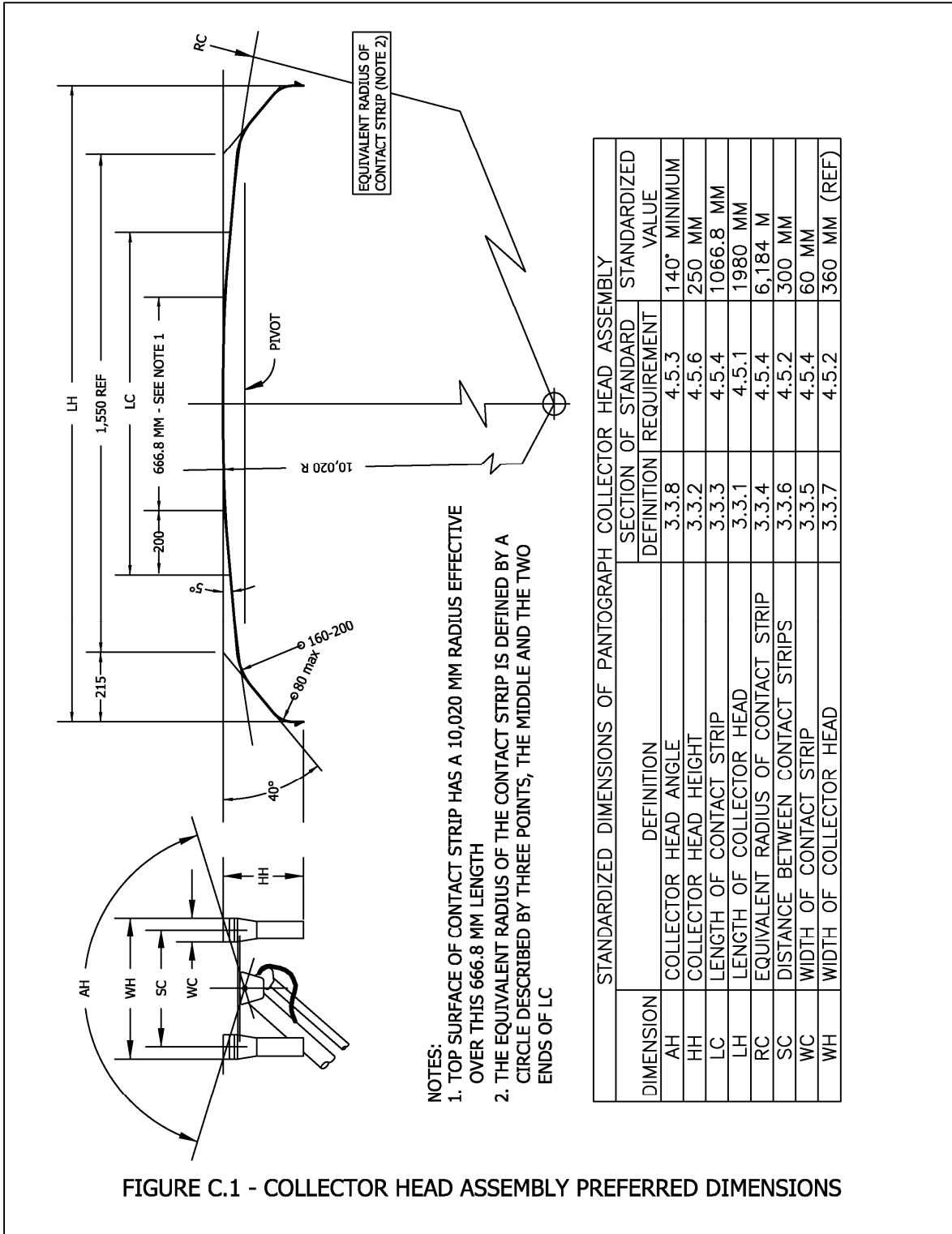

## 1 Annex D (normative) Test Requirements

Subclause	Test Title	Qualification Tests	Acceptance Tests	Investigation Tests	Combined Tests
5.8.1	Visual Inspection	X	X		
5.8.2	Weight	X			
5.8.3	Dimensions	X	X		
5.8.4	Automatic Drop Down System Functional Test	X	X		
5.8.5	Operating Tests	X	X		
5.8.6	Climatic Operating Tests	X			
5.8.7	Mechanical Endurance Tests	X			
5.8.8	Resonant Frequency Search	X			
5.8.9	Transverse Vibration Withstand Test	X			
5.8.10	Shock Withstand Test	X			
5.8.11	Transverse Rigidity Test	X			
5.8.12	Air Tightness Test	X	X		
5.8.13	Climatic Air Tightness Test	X			
5.8.14	Measurement of Degrees of Freedom of Collector Head	X			
5.8.15	Measurement of Retaining Force in Lock Down Position	X			
5.8.16	Measurement of Static Force (Qualification Test)	X			
5.8.17	Measurement of Static Force (Acceptance Test)		X		
5.8.18	Measurement of Total Force	X			
5.8.19	Rated and Maximum Current Heating Tests (Vehicle at Standstill)	X			
5.8.20	Rated and Maximum Current Heating Tests (Vehicle Running)	X			
5.8.21	Insulation and Dielectric Tests	X	X		
5.8.22	Current Collection Test	X			
5.8.23	Pantograph Tracking Test	X			

# 1 Annex E (normative) Customer Specification Requirements

Description	Definition	Requirement	Specification
<b>Type of pantograph single-arm type unless otherwise specified)</b>	3.2	4.1	
Single-arm type			_____
Two-arm diamond			_____
Four-arm diamond			_____
<b>Pantograph physical dimensions</b>			
Insulator Mounting Spacing – Longitudinal (IL)	3.3.14	4.3	_____ mm (in)
Insulator Mounting Spacing – Transverse (IT)	3.3.15	4.3	_____ mm (in)
Insulator Height (IH)	3.3.16	4.3	_____ mm (in)
Frame Width (FW)	3.3.17	4.3	_____ mm (in)
Overall Length (OL)	3.3.18	4.3	_____ mm (in)
Overall Width (OW)	3.3.19	4.3	_____ mm (in)
<b>Pantograph operating positions</b>			
Maximum working height (HMAX)	3.3.10	4.4	_____ mm (in)
Minimum working height (HMIN)	3.3.11	4.4	_____ mm (in)
Lock-down height (HL)	3.3.13	4.4	_____ mm (in)
<b>Collector head requirements</b>			
Length of the collector head (LH)	3.3.1	4.5.1	_____ mm (in)
Width of the collector head (WH)	3.3.2	4.5.2	_____ mm (in)
Collector head height (HH)	3.3.3	4.5.3	_____ mm (in)
Number of contact strips		4.5.2	_____ strips
Contact strip length (LC)	3.3.4	4.5.4	_____ mm (in)
Contact strip type (one or two-piece curved design, bonded or soldered)			
Single-piece curved design, bonded or soldered		4.5.4	_____
Straight three-piece with socket rail		4.5.4	_____
Width of contact strip (WC)	3.3.6	4.5.4	_____ mm (in)
Distance between contact strips (SC)	3.3.7	4.5.2	_____ mm (in)
Collector head angle (140-degrees) (AH)	3.3.8	4.5.3	_____ degrees



Description	Definition	Requirement	Specification
			Nom _____ Bar (psig) Max _____ Bar (psig)
Manual emergency operating system		4.7.2	
Methodology		4.7.1	_____ mechanical _____ pneumatic _____ other (specify)
Option for exterior release		4.7.1	_____ Yes _____ No
Automatic drop-down system method of activation	3.2.16	4.7.3	_____ electrical _____ mechanical _____ pneumatic
<b>Other requirements</b>			
Design life		4.8.1	_____ Years _____ km (miles)
Operating environment (if different from that specified in IEEE Std. 1478™-2001)		4.8.3	Describe in detail
High Voltage Cable Connection (if other than preferred two-hole crimp style flat terminal lug)		4.8.7	Type _____ _____

1