



## NEW YORK CITY TRANSIT

### New Train Procurement for NYCT Division A (R142)

# Monitoring and Diagnostics System (MDS)

# Compatibility

APPROVALS :

Prepared : Carl Duhamel  
Project Engineer

Verified : Pierre Raymond  
Software Designer

Approved : Michel Juteau  
Manager

Name / Title

Signature / Date

| Document No.  | 043-BRA-0072 | Revision           | 9        |
|---|--------------|--------------------|----------|
| The information, technical data and the designs disclosed herein are the exclusive property of Bombardier Inc. or contain proprietary rights of others and are not to be used or disclosed without the written consent of Bombardier Inc. The recipient of this document, by its retention and use agrees to hold in confidence the technical data and designs contained herein. The foregoing shall not apply to persons having proprietary rights to such information, technical data or such designs to the extent that such rights exist. |              | Date<br>(yy.mm.dd) | 01.07.13 |

## Table of Contents

|   |          |
|---|----------|
| <b>1. REVISIONS .....</b>                           | <b>4</b> |
| <b>2. REFERENCES .....</b>                          | <b>5</b> |
| 2.1 ECHELON .....                                   | 5        |
| 2.2 MOTOROLA .....                                  | 5        |
| <b>3. GLOSSARY .....</b>                            | <b>6</b> |
| <b>4. SYSTEM OPERATION.....</b>                     | <b>7</b> |
| 4.1 ARCHITECTURE .....                              | 7        |
| 4.2 NODE OBJECT.....                                | 8        |
| 4.2.1 <i>Node object - Object 0</i> .....           | 9        |
| 4.2.1.1 nvi00Request .....                          | 9        |
| 4.2.1.2 nvo00Status.....                            | 9        |
| 4.2.1.3 nvi00FileReq.....                           | 9        |
| 4.2.1.4 nvo00FileStat .....                         | 9        |
| 4.2.1.5 nvi00FilePos .....                          | 10       |
| 4.2.1.6 Node Configuration properties.....          | 10       |
| 4.2.2 <i>UNIT INFO - Object 1</i> .....             | 10       |
| 4.2.2.1 nvi01UnitInfo.....                          | 10       |
| 4.2.2.2 nvo01UnitInfo.....                          | 10       |
| 4.2.2.3 Object Configuration properties.....        | 11       |
| 4.2.3 <i>TrOUBLE - Object 2</i> .....               | 11       |
| 4.2.3.1 nvi02Trouble.....                           | 11       |
| 4.2.3.2 nvo02Trouble.....                           | 11       |
| 4.2.4 <i>Train Functions - Object 3</i> .....       | 12       |
| 4.2.4.1 nvi03Function .....                         | 12       |
| 4.2.5 <i>Train Functions - Object 4</i> .....       | 12       |
| 4.2.5.1 nvo04Function .....                         | 12       |
| 4.2.6 <i>Display Time - Object 5</i> .....          | 12       |
| 4.2.6.1 nvi05DisplayTime.....                       | 12       |
| 4.2.7 <i>Display Time - Object 6</i> .....          | 12       |
| 4.2.7.1 nvo06DisplayTime.....                       | 12       |
| 4.2.8 <i>MDS Time - Object 7</i> .....              | 13       |
| 4.2.8.1 nvi07MDSTime .....                          | 13       |
| 4.2.9 <i>MDS Time - Object 8</i> .....              | 13       |
| 4.2.9.1 nvo08MDSTime .....                          | 13       |
| 4.2.10 <i>odometer INFO - Object 9</i> .....        | 13       |
| 4.2.10.1 nvi09OdometerVal .....                     | 13       |
| 4.2.10.2 nvo09OdometerVal .....                     | 14       |
| 4.2.10.3 Object Configuration properties .....      | 14       |
| 4.2.10.4 nci09MinSendT .....                        | 14       |
| 4.3 FUNCTIONAL DESCRIPTION .....                    | 14       |
| 4.3.1 <i>Unit information - Object 1</i> .....      | 14       |
| 4.3.1.1 Structure Unit_Info .....                   | 15       |
| 4.3.1.2 Structure A_Car .....                       | 15       |
| 4.3.1.3 Structure B_Car .....                       | 16       |
| 4.3.1.4 Car Order Presentation Rules.....           | 17       |
| 4.3.2 <i>Troubles - Object 2</i> .....              | 18       |
| 4.3.2.1 Trouble transmission exception .....        | 19       |
| 4.3.2.2 Trouble marker scheme.....                  | 19       |
| 4.3.3 <i>Train functions - Object 3 and 4</i> ..... | 22       |
| 4.3.4 <i>Display time - Object 5 and 6</i> .....    | 24       |
| 4.3.5 <i>MDS time - Object 7 and 8</i> .....        | 25       |

|           |  |           |
|-----------|--|-----------|
| 4.3.6     | <i>Odometer info – object 9</i> .....                    | 25        |
| 4.3.6.1   | Structure Odometer_Info .....                            | 25        |
| 4.3.6.2   | Structure Odom_Car .....                                 | 26        |
| 4.4       | NODE INSTALLATION .....                                  | 26        |
| 4.4.1     | <i>Power-up guidelines</i> .....                         | 27        |
| 4.4.2     | <i>R142 Node’s PROGRAM ID</i> .....                      | 27        |
| 4.4.3     | <i>R142A Node’s PROGRAM ID</i> .....                     | 28        |
| 4.5       | AUDIBLE ALARMS.....                                      | 28        |
| 4.5.1     | <i>Parking brake with train in motion</i> .....          | 28        |
| 4.5.2     | <i>PEHU</i> .....  | 28        |
| 4.5.3     | <i>Direction set to reverse</i> .....                    | 28        |
| 4.5.4     | <i>PEI Indication</i> .....                              | 28        |
| 4.5.5     | <i>Spare audible alarm</i> .....                         | 28        |
| 4.6       | DATA FORMAT .....  | 29        |
| 4.7       | TRAFFIC CONSIDERATION .....                              | 30        |
| 4.8       | IUNG RESPONSE TIME .....                                 | 30        |
| <b>5.</b> | <b>APPENDIX</b> .....                                    | <b>31</b> |
| 5.1       | APPENDIX 8 : TOD SCREENS.....                            | 31        |
| 5.1.1     | <i>TOD Screens flowchart</i> .....                       | 33        |
| 5.1.2     | <i>General Description</i> .....                         | 34        |
| 5.1.3     | <i>Operating screen (SCR-A30)</i> .....                  | 36        |
| 5.1.4     | <i>Route and Destination setup</i> .....                 | 41        |
| 5.1.4.1   | Route Pre-Selection Screen (SCR-B30).....                | 41        |
|           | Route Selection Screen (SCR-C30).....                    | 44        |
| 5.1.4.3   | Stopping Pattern Selection Screen (SCR-D30).....         | 49        |
| 5.1.4.4   | Special announces and interior messages (SCR-B20).....   | 53        |
| 5.1.5     | <i>Display time setup Screen (SCR-B10)</i> .....         | 57        |
| 5.1.6     | <i>Trouble screen (Default) (SCR-A20)</i> .....          | 58        |
| 5.1.7     | <i>Trouble SScreen with door trouble (SCR-A20)</i> ..... | 60        |
| 5.1.8     | <i>AAS setting error handling screen</i> .....           | 62        |



1. REVISIONS

| Revision | Date | Description of Changes |
|----------|------|------------------------|
|----------|------|------------------------|

## 2. REFERENCES

### 2.1 ECHELON

|                     |   |
|---------------------|---|
| 078-0120-01C, REV.3 | LONMARK Application Layer Interoperability Guidelines |
| N/A, May 1997       | The SNVT Master List and Programmer's Guide           |
| N/A, May 1997       | The SCPT Master List                                  |

### 2.2 MOTOROLA

|                |                                  |
|----------------|----------------------------------|
| DL159/D, Rev.3 | LONWORKS® Technology Device Data |
|----------------|----------------------------------|

### 3. GLOSSARY

|        |   |
|--------|---|
| Car    | Car located at both ends of Operating Units where operator consoles are located.                                |
| Car    | Car located between “A” Cars.   |
| 3U     | Standard height of a communication style card cage.   |
| ADC    | Analog to Digital Converter   |
| Car ID | A unique number to each car. It is a shortened equivalent to the serial number.                                 |
| CB     | Circuit Breaker   |
| EMI    | Electromagnetic Interference  |
| EMC    | Electromagnetic Compatibility   |
| ESD    | Electrostatic Discharge   |
| FLASH  | Type of integrated circuit memory that permanently records information previously stored in one fast operation. |
| FPGA   | Field Programmable Gate Array   |
| IUN    | Inter-Unit Network  |
| LED    | Light Emitting Diode  |
| LLS    | Low Level Software  |
| LON    | Abbreviation of LONWORKS®.  |
| LRU    | Line Replaceable Unit   |
| LVDN   | Low Input Voltage Distribution Network  |
| MBS    | Microprocessor Based System   |
| MDS    | Monitoring Diagnostic System  |
| N/A    | Not Applicable  |
| PCB    | Printed Circuit Board   |
| PTE    | Portable Test Equipment   |
| RAM    | Random Access Memory  |
| RS-232 | Serial Communication Standard   |
| RTC    | Real Time Clock   |
| RX     | Receive Signal  |
| SMX    | Proprietary Standard Format for LON Transceiver module  |
| SRS    | Software Requirements Specifications  |
| SVGA   | Super Video Graphic Array. High resolution video format   |
| TBD    | To be defined   |
| TX     | Transmit Signal   |
| VGA    | Video Graphic Array   |

## 4. SYSTEM OPERATION

### 4.1 ARCHITECTURE

When two units are connected together, all digital information is transmitted through a general redundant Trainline Multiplexer (TMX). The TMX carries a multiplexed stream of data through the automatic coupler. This data stream combines information from the Communication Digital Audio Network, the Propulsion/Command Network and the Inter-Unit Network (IUN). The latter is used as an isolating link between the Train Networks of each unit. For nodes present on the IUN, the TMX appears as a LonWorks® Router set to repeater mode<sup>1</sup>.

No equipment other than the Inter-Unit Network Gateway (IUNG) will be able to exchange information from the Train Networks between units using the redundant IUN.

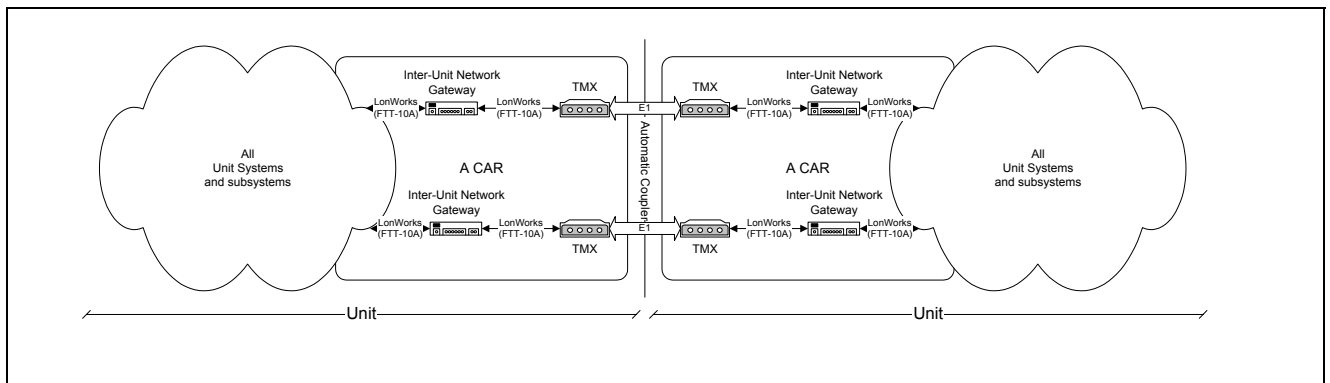

**Figure 1 - Inter-Unit Network (IUN) Architecture**

<sup>1</sup> Refer to Echelon's documentation #078-0018-01C for more information on router operation.

## 4.2 NODE OBJECT

Following is a diagram depicting the Unit interoperable node object implemented within the IUNG:

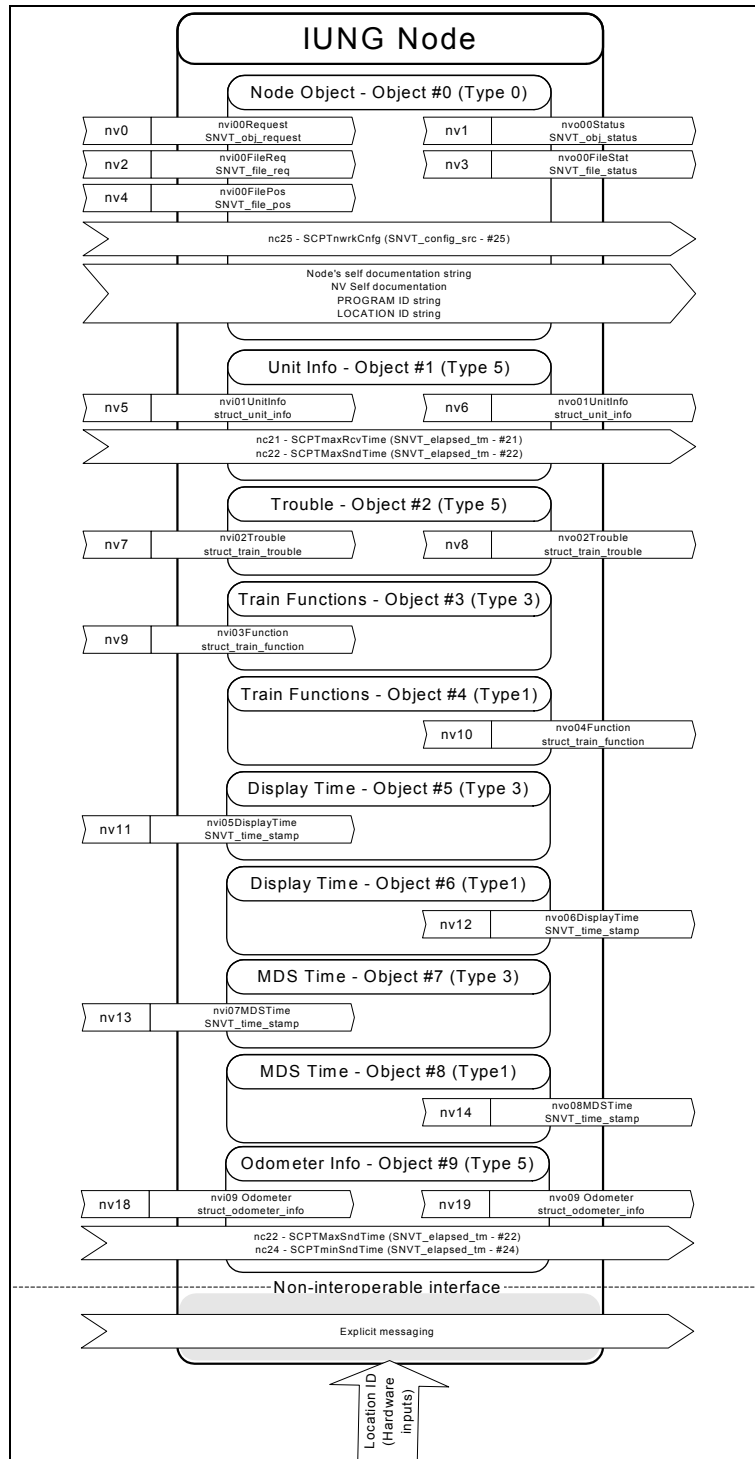

Figure 2 - IUNG Node Object

All variables presented in Node Object (Object 0) are described in details in the *LonMark™ Application Layer Interoperability Guidelines, v3.0* document. Network variables of Object 1 to 4 are presented in the later sections.

#### 4.2.1 NODE OBJECT - OBJECT 0

The node object provides mechanisms for requesting object modes and for reporting status of objects within the node, as well as for the node as a whole. In addition the node object include network variables and configuration properties relating to the complete node, such as network management support.

##### 4.2.1.1 nvi00Request

Type : Input, SNVT\_obj\_request

Declaration : network input sd\_string("@0|1") SNVT\_obj\_request nvi00Request;

Description : This input variable provides the mechanism to request a particular mode for object within the node or the node as a whole. Refer to the LONMARK™ standard for additional details.

NVindex: 0

NVselector: 3FFF (hex)

##### 4.2.1.2 nvo00Status

Type : Output, SNVT\_obj\_status

Declaration : network output sd\_string("@0|2") SNVT\_obj\_status nvo00Status;

Description : This output network variable reports the status for any object within the node.

NVindex: 1

NVselector: 3FFE (Hex)

##### 4.2.1.3 nvi00FileReq

Type : Input, SNVT\_file\_req

Declaration : network input sd\_string("@0|3") SNVT\_file\_req nvi00FileReq;

Description : This input network variable is used to perform file transfer, as described in the Echelon's *File Transfer Bulletin* (005-0025-01)

NVindex: 2

NVselector: 3FFD (hex)

##### 4.2.1.4 nvo00FileStat

Type : Output, SNVT\_file\_status

Declaration : network output sd\_string("@0|4") SNVT\_file\_status nvoFileStat;

Description : This input network variable is used to perform file transfer, as described in the Echelon's *File Transfer Bulletin* (005-0025-01)

Destination : Sent using explicit messaging.

NVindex: 3

NVselector: 3FFC (hex)

addressing: Unicast subnet node, ACK, no priority and no turnaround

#### 4.2.1.5 nvi00FilePos

Type : Input, SNVT\_file\_pos  
Declaration : network input sd\_string("@0|") SNVT\_file\_pos nvo00FilePos;  
Description : This input network variable is used to perform file transfer, as described in the Echelon's *File Transfer Bulletin* (005-0025-01)  
NVindex: 4  
NVselector: 3FFB (hex)

#### 4.2.1.6 Node Configuration properties

##### 4.2.1.6.1 nciNetConfig

All nodes that support self-installation must provide a configuration property to allow a network tool to also install the node.

Type : nc25, SCPT\_nwrk\_cnfg  
Declaration : config network input sd\_string("&0,,0\x90,25") SNVT\_config\_src nciNetConfig;  
Default : CFG\_LOCAL  
NVindex: 15  
NVselector: 3FF0 (hex)

#### 4.2.2 UNIT INFO - OBJECT 1

This controller object (type 5) is used to implement the necessary mechanism for unit information transfer when two units operate together to form a train in revenue service.

##### 4.2.2.1 nvi01UnitInfo

Type : Input, struct\_unit\_info  
Declaration : network input sd\_string("#1|1") struct\_unit\_info nvi01UnitInfo;  
Description : This network input variable is used to received the unit information coming from the other unit.  
NVindex: 5  
NVselector: 0002 (hex)

##### 4.2.2.2 nvo01UnitInfo

Type : Ouput, struct\_unit\_info  
Declaration : network output sync sd\_string("#1|2") struct\_unit\_info nvo01UnitInfo;  
Description : This network output variable is used to provide information about the local unit to the other unit.  
Destination : nvi01UnitInfo on the other unit.  
NVindex: 6  
NVselector: 0002 (hex)  
addressing: Unicast subnet node, ACK, no priority and no turnaround

### 4.2.2.3 Object Configuration properties

#### 4.2.2.3.1 nci01MaxSendT

This configuration property is used to control the maximum period of time that expires before the object automatically transmits the current value of its primary output network variable. This provides a heartbeat output that can be used by destination objects to ensure that the node is still healthy.

Type : nc22, SCPTmaxSndTime  
Declaration : config network input sd\_string("&2,6,0\x80,22") SNVT\_elapsed\_tm nci01MaxSendT;  
Default : 5 seconds  
NVindex: 16  
NVselector: 3FEF (hex)

#### 4.2.2.3.2 nci01MaxReceiveT

This configuration property is used to control the maximum amount of time that elapses after a network variable update before the node adopt the default behavior. This provides a heartbeat verification that can be used by the objects to ensure that the emitting node is still healthy.

Type : nc21, SCPTmaxRcvTime  
Declaration : config network input sd\_string("&2,5,0\x80,21") SNVT\_elapsed\_tm nci01MaxReceiveT;  
Default : 15 seconds  
NVindex: 17  
NVselector: 3FEE (hex)

### 4.2.3 TROUBLE - OBJECT 2

This controller object (type 5) is used to implement the necessary mechanism for unit trouble information transfer when two units operate together to form a train in revenue service.

#### 4.2.3.1 nvi02Trouble

Type : Input, struct\_train\_trouble  
Declaration : network input sd\_string("#2|1") struct\_train\_trouble nvi02Trouble;  
Description : This network input variable is used to received the unit trouble information coming from the other unit.  
NVindex: 7  
NVselector: 0003 (hex)

#### 4.2.3.2 nvo02Trouble

Type : Ouput, struct\_train\_trouble  
Declaration : network output sync sd\_string("#2|2") struct\_train\_trouble nvo02Trouble;  
Description : This network output variable is used to provide information about the local unit troubles to the other unit.  
Destination : nvi02Trouble on the other unit.  
NVindex: 8  
NVselector: 0003 (hex)  
addressing: Unicast subnet node, ACK, no priority and no turnaround

#### 4.2.4 TRAIN FUNCTIONS - OBJECT 3

This open loop actuator object (type 3) is used to implement train functions that are sent from the other unit.

##### 4.2.4.1 nvi03Function

Type : Input, struct\_train\_function  
Declaration : network input sd\_string("#3|1") struct\_train\_function nvi03Function;  
Description : This network input variable is used to received train functions that originate from the other unit  
NVindex: 9  
NVselector: 0004 (hex)

#### 4.2.5 TRAIN FUNCTIONS - OBJECT 4

This open loop sensor object (type 1) is used to implement train function transmission to the other unit.

##### 4.2.5.1 nvo04Function

Type : Ouput, struct\_train\_function  
Declaration : network output sync sd\_string("#4|1") struct\_train\_function nvo04Function;  
Description : This network output variable is used to send train functions that originate from the local unit to the other unit.  
Destination : nvi03Function on the other unit.  
NVindex: 10  
NVselector: 0004 (hex)  
addressing: Unicast subnet node, ACK, no priority and no turnaround

#### 4.2.6 DISPLAY TIME - OBJECT 5

This open loop actuator object (type 3) is used to receive Display Time sent from the other unit.

##### 4.2.6.1 nvi05DisplayTime

Type : Input, SNVT\_time\_stamp  
Declaration : network input sd\_string("@5|1") SNVT\_time\_stamp nvi05DisplayTime;  
Description : This network input variable is used to received display time information on change from the other unit  
NVindex: 11  
NVselector: 0005 (hex)

#### 4.2.7 DISPLAY TIME - OBJECT 6

This open loop sensor object (type 1) is used to send Display Time information to the other unit.

##### 4.2.7.1 nvo06DisplayTime

Type : Ouput, SNVT\_time\_stamp  
Declaration : network output sync sd\_string("@6|1") SNVT\_time\_stamp nvo06DisplayTime;

Description : This network output variable is used to send the display time on change to the other unit. The time value is set accordingly to Greenwich Mean Time (GMT)

Destination : nvi05DisplayTime on the other unit.

NVindex: 12

NVselector: 0005 (hex)

addressing: Unicast subnet node, ACK, no priority and no turnaround

#### 4.2.8 MDS TIME - OBJECT 7

This open loop actuator object (type 3) is used to receive MDS Time sent from the other unit.

##### 4.2.8.1 nvi07MDSTime

Type : Input, SNVT\_time\_stamp

Declaration : network input sd\_string("@7|1") SNVT\_time\_stamp nvi07MDSTime;

Description : This network input variable is used to received MDS time information on change from the other unit NVindex: 13

NVselector: 0006 (hex)

#### 4.2.9 MDS TIME - OBJECT 8

This open loop sensor object (type 1) is used to send MDS Time information to the other unit.

##### 4.2.9.1 nvo08MDSTime

Type : Ouput, SNVT\_time\_stamp

Declaration : network output sync sd\_string("@8|1") SNVT\_time\_stamp nvo08MDSTime;

Description : This network output variable is used to send the MDS time on change to the other unit. The time value is set accordingly to Greenwich Mean Time (GMT)

Destination : nvi07MDSTime on the other unit.

NVindex: 14

NVselector: 0006 (hex)

addressing: Unicast subnet nodeID, ACK, no priority and no turnaround

#### 4.2.10 ODOMETER INFO - OBJECT 9

This controller object (type 5) is used to implement the necessary mechanism for odometer information transfer when two units operate together to form a train in revenue service.

##### 4.2.10.1 nvi09Odometer

Type : Input, struct\_odometer\_info

Declaration : network input sd\_string("#9|1") struct\_odometer\_info nvi09Odometer;

Description : This network input variable is used to received the odometer information coming from the other unit.

NVindex: 18

NVselector: 0007 (hex)

#### 4.2.10.2 nvo09Odometer

Type : Ouput, struct\_odometer\_info  
 Declaration : network output sync sd\_string("#9|2") struct\_odometer\_info nvo09Odometer;  
 Description : This network output variable is used to provide the local odometer information to the other unit.  
 Destination : nvi09Odometer on the other unit.  
 NVindex: 19  
 NVselector: 0007 (hex)  
 addressing: Unicast subnet node, ACK, no priority and no turnaround

#### 4.2.10.3 Object Configuration properties

##### 4.2.10.3.1 nci09MaxSendT

This configuration property is used to control the maximum period of time that expires before the object automatically transmits the current value of its primary output network variable. This provides a heartbeat output that can be used by destination objects to ensure that the node is still healthy.

Type : nc22, SCPTmaxSndTime  
 Declaration : config network input sd\_string("&2,19,0\x80,22") SNVT\_elapsed\_tm nci09MaxSendT;  
 Default : 15 minute  
 NVindex: 20  
 NVselector: 3FEB (hex)

##### 4.2.10.4 nci09MinSendT

This configuration property is used to control the minimum period between output network variable transmissions (maximum transmission rate). It provides a way to tailor the output network variable transmission rate to available bandwidth.

Type : nc24, SCPTminSndTime (equivalent SNVT : SNVT\_elapsed\_tm)  
 Declaration : config network input sd\_string("&2,19,0\x80,24") SNVT\_elapsed\_tm nci09MinSendT;  
 Default : 1 minutes  
 NVindex: 21  
 NVselector: 3FEA (hex)

### 4.3 FUNCTIONAL DESCRIPTION

#### 4.3.1 UNIT INFORMATION - OBJECT 1

The unit information will regroup all data pertinent to the actual status of a unit. This information will be used to display the operating condition of the other unit and to display the required information on the Operating screen. The following information is required within the variable, as required by the Technical Specification :

1. Consist indication (Consist indication includes, cars in train, with car numbers shown in order with lead car indicated, as per TS-6.6.6.2)

This information will be received from the other unit through the *nvi01UnitInfo* input network variable. Similarly, the data of the current unit will be sent to the other unit via the *nvo01UnitInfo* output variable.

Both of these variable are presented within Node Object #1. These variables will contain data structures with all relevant unit information.

The *nvi01UnitInfo* network variable will be propagated from the node immediately upon any value updates within the structure or after the MaxSndTime timer as expired.

#### 4.3.1.1 Structure Unit\_Info

The following data structure, defined as *struct\_unit\_info*, will be used :

|                  |                   |   |                          |
|------------------|-------------------|---|--------------------------|
| typedef struct { |                   |   |                          |
| struct_A_car     | Coupled_A_Car;    | //Structure describing the coupled A car    | 6 bytes                  |
| struct_A_car     | Other_A_Car;      | //Structure describing the other A car      | 6 bytes                  |
| short int        | siNum_B_Car;      | //Indicated how many B cars are in the unit | 1 byte                   |
| struct_B_car     | List_B_Car[4];    | //List of structures describing the B cars  | 12 bytes                 |
| unsigned short   | uSpare[4];        | //Spare - 4 bytes                           |                          |
| <u>4 bytes</u>   |                   |   |                          |
| }                | struct_unit_info; | //  | Total size of : 29 bytes |

- Coupled\_A\_Car :** Field containing all information necessary to describe the coupled “A” car of the unit. The complete description of the *struct\_A\_Car* data structure is given below. When the unit is not coupled, this field may represent any of the two “A” cars of the unit.
- Other\_A\_Car :** Field containing all information necessary to describe the un-coupled “A” car within a unit for a two unit train configuration. The complete description of the *struct\_A\_car* data structure is given below. When the unit is not coupled, this field may represent any of the two “A” cars of the unit.
- siNum\_B\_Car :** This field provides information about the number of “B” cars contained within the unit. It indicates the number of element contained within the *List\_B\_Car* field.
- List\_B\_Car :** List of elements representing each “B” car present in the unit. The list length is given by the *siNum\_B\_Car* field. The first element in the list indicates which “B” car is physically connected to the coupled “A” car of the unit, as referenced in the *Coupled\_A\_Car* field. The following element corresponds to the next physically connected “B” car. The last element of the list indicates which “B” car is connected the un-coupled “A” car of the unit, as referenced by the *Other\_A\_Car* field. The complete description of the *struct\_B\_Car* data structure is given below.
- uSpare :** Reserved four (4) bytes data buffer for future use.

#### 4.3.1.2 Structure A\_Car

The data describing each “A” cars and “B” cars will be contained within two data structures named *struct\_A\_car* and *struct\_B\_car* respectively.

|                  |                 |   |         |
|------------------|-----------------|---|---------|
| typedef struct { |                 |   |         |
| long             | liCarID;        | //Car ID. The sign indicates the orientation relative to the coupled A car ( + for direct, - for reverse) | 2 bytes |
| unsigned         | uMC_active:1;   | //Set when the MC is keyed in   | .       |
| unsigned         | uForward:1;     | //Set when the MC is in forward   | .       |
| unsigned         | uReverse:1;     | //Set when MC is in reverse   | .       |
| unsigned         | :5;             | // spare (padding)  | 1 byte  |
| unsigned         | uMDCL_active:1; | //Set when the MDC Left is active   | .       |
| unsigned         | :7;             | // spare (padding)  | 1 byte  |
| unsigned         | uMDCR_active:1; | //Set when the MDC right is active  | .       |

|                 |                     |   |               |
|-----------------|---------------------|---|---------------|
| unsigned        | :7;                 | // spare (padding)  | 1 byte        |
| unsigned        | uTraction1Failed:1; | // Set when the end1 truck no longer provides traction        |               |
| unsigned        | uTraction2Failed:1; | // Set when the end2 truck no longer provides traction        |               |
| unsigned        | uFriction1Failed:1; | // Set when the end1 truck no longer provides friction brakes |               |
| unsigned        | uFriction2Failed:1; | // Set when the end2 truck no longer provides friction brakes |               |
| unsigned        | :4;                 | // spare (padding)  | <u>1 byte</u> |
| } struct_A_car; | //                  | Total size of :   | 6 bytes       |

- liCarID : This field will provide the CAR ID information of the car. It will also indicate the orientation of the car relative to the coupled “A” car of the unit. The orientation is termed *forward* when the end 1 of the car is closer to the coupled “A” car of the unit. This condition will be indicated as a positive CAR ID value. The orientation is termed *reverse* when the end 2 of the car is closer to the coupled “A” car of the unit. This condition will be indicated as a negative CAR ID value. If the CAR ID is undetermined, a zero (0) value shall be used.
- uMC\_active : Bit field. This bit is set when the Master Controller (MC) in the “A” car is active.
- uForward : Bit field. This bit is set when the Master Controller (MC) direction control is set to Forward. When the MC in this “A” car is inactive, the bit must be reset.
- uReverse : Bit field. This bit is set when the Master Controller (MC) direction control is set to Reverse. When the MC in this “A” car is inactive, the bit must be reset.
- uMDCL\_active : Bit field. This bit is set when the left Master Door Controller (MDC) of the “A” car is active.
- uMDCR\_active : Bit field. This bit is set when the right Master Door Controller (MDC) of the “A” car is active.
- uTraction1Failed : Bit field. This bit is set when the propulsion unit of the truck 1 is no longer able to provide traction.
- uTraction2Failed : Bit field. This bit is set when the propulsion unit of the truck 2 is no longer able to provide traction.
- uFriction1Failed : Bit field. This bit is set when the brake control unit of the truck 1 is no longer able to provide friction braking.
- uFriction2Failed : Bit field. This bit is set when the brake control unit of the truck 2 is no longer able to provide friction braking.

#### 4.3.1.3 Structure B\_Car

|                  |                     |   |               |
|------------------|---------------------|---|---------------|
| typedef struct { |                     |   |               |
| long             | liCarID;            | //Car ID. The sign indicates the orientation relative         | 2 bytes       |
|                  |                     | // to the coupled A car ( + for direct, - for reverse)        |               |
| unsigned         | uTraction2Failed:1; | // Set when the end2 truck no longer provides traction        |               |
| unsigned         | uFriction1Failed:1; | // Set when the end1 truck no longer provides friction brakes |               |
| unsigned         | uFriction2Failed:1; | // Set when the end2 truck no longer provides friction brakes |               |
| unsigned         | :5;                 | // Spare  | <u>1 byte</u> |
| } struct_B_car;  | //                  | Total size of :   | 3 bytes       |

- liCarID : This field will provide the CAR ID information of the car. It will also indicate the orientation of the car relative to the coupled “A” car of the unit. The orientation is termed *forward* when the end 1 of the car is closer to the coupled “A” car of the unit. This condition will be indicated as a positive CAR ID value. The orientation is termed *reverse* when the end 2 of the car is closer to

the coupled “A” car of the unit. This condition will be indicated as a negative CAR ID value. If the CAR ID is undetermined, a zero (0) value shall be used.

- uTraction2Failed : Bit field. This bit is set when the propulsion unit of the truck 2 is no longer able to provide traction.
- uFriction1Failed : Bit field. This bit is set when the brake control unit of the truck 1 is no longer able to provide friction braking.
- uFriction2Failed : Bit field. This bit is set when the brake control unit of the truck 2 is no longer able to provide friction braking.

#### 4.3.1.4 Car Order Presentation Rules

The Train picture will be managed as described below:

Case #1: No MC active.

Result: The higher Car ID of the uncoupled A car shall be displayed on right side of screen with no arrows displayed and all MC box displayed in gray in both case: 1 unit and 2 unit train consist.

Case #2: One MC active on one unit train consist

Result: Car with the MC active shall be shown on right side of the screen with the MC box displayed in green.

When the MC is in forward mode, the arrows located on right side of the screen shall be displayed in green.

When the MC is in reverse mode, the arrows located on left side of the screen shall be displayed in green.

Case #3: One MC active on two unit train consist.

Result: Unit which include the MC active shall be shown on right side of the screen with the associated MC box displayed in green.

In this case, when the active MC is located in the Head Car (uncoupled) and the MC is in forward mode, the arrows located on right side of the screen shall be displayed in green.

When the MC is in reverse mode, the arrows located on left side of the screen shall be displayed in green

When the active MC is located in center Car (coupled) and the MC is in forward mode, the arrows located on left side of the screen shall be displayed in green.

When the MC is in reverse mode, the arrows located on right side of the screen shall be displayed in green.

Case #4: Two MC active in one unit train consist

Result: The higher Car ID shall be displayed on right side of screen with no arrow displayed and both MC boxes shall be displayed in green

Case #5: More than one MC active on two unit train consist

Result: The higher Car ID of the uncoupled A car shall be displayed on right side of screen with no arrow displayed and MC box shall be displayed in green at the actives MC locations.

Case #6: More than one MC active after the transition from uncoupled to coupled of two unit.

Result: The higher Car ID of the uncoupled A car shall be displayed on right side of screen with the associated MC boxes displayed in green and no arrows displayed on the screen.

#### 4.3.2 TROUBLES - OBJECT 2

Each unit will maintain a complete list of current train troubles. The list is composed of two distinct records:

- Local Unit Troubles
- Remote Unit Troubles

It is the responsibility of the local unit MDS to maintain the Local Unit Trouble list. When the Local Unit Trouble list is modified (addition or removal of troubles) the local MDS must send the complete modified Local Unit Trouble list to the other unit. This list may also be transferred upon request from the other unit's IUNG (refer to section 4.3.3).

The transfer of the list will be conducted using the *nvi02Trouble* variable as input from the other unit and *nvo02Trouble* as output to the other unit using acknowledge services. If the receiving end detects an incomplete or erroneous transfer, it may request a new list download using the mechanism described in section 4.3.3. The erroneous transfer is detected when there is a discontinuity in the trouble index "sNumTrouble" or when the total number of received current trouble do not correspond to the total number of current trouble announced by the variable "sTotalTrouble".

The variables used for the list transfer are presented within object 2 (refer to Figure 2). These variables contain a data structure of the following format :

|                  |                       |   |                         |
|------------------|-----------------------|---|-------------------------|
| typedef struct { |                       |   |                         |
| signed short     | sNumTrouble;          | //Index of trouble within complete list               | 1 byte                  |
| signed short     | sTotalTrouble;        | //Total number of current trouble in unit             | 1 byte                  |
| unsigned short   | usTroubleID;          | //The Trouble ID                                      | 1 byte                  |
| long int         | lCarID;               | //Car ID where the trouble is located, if applicable. | 2 bytes                 |
| unsigned long    | usLocation;           | //Indicates which scheme of marking is to be used     | <u>2 bytes</u>          |
| }                | struct_train_trouble; | //  | Total size of : 7 bytes |

- sNumTrouble : This field indicates the current ordinal number of the trouble in reference to the total number of element present in the Local Unit Trouble list.
- sTotalTrouble : Indicates the total number trouble element currently present in the list for the transfer taking place.
- usTroubleID : This field references to a Trouble ID present in the Trouble List which corresponds to the detected trouble.
- liCarID : Indicates the CAR ID identifying the car from which the trouble originates. The CAR ID must correspond to one of the CAR ID provided within the *Unit Information* data structure.
- usLocation : This field is used to identify the type of marking used to graphically identify the trouble on the Trouble screen. Please refer to section 4.3.2.2.

One packet of this "struct\_train\_trouble" shall be sent for each trouble occurrence. All packets of this "struct\_train\_trouble" associated to the current trouble list shall be sent each time a new trouble occurs or is cleared. When all trouble has been cleared the "struct\_train\_trouble" shall be sent with "sTotalTrouble" set to zero.

A request of the trouble list shall be done using TROUBLE\_LIST\_REQUEST after the unit coupling transition and each time an error is detected during a trouble list transfer to insure the proper trouble list synchronization between both units.

#### 4.3.2.1 Trouble transmission exception











There is two trouble transmission exception :

When a door trouble is set, only one trouble shall be sent per car ID with the Location ID bits set for each door opening in problem in the car in trouble.

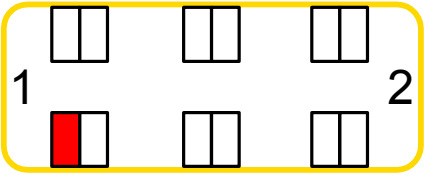
When a train wide trouble occur, no trouble shall be added to the trouble list to avoid duplication of the trouble transmission in both way the IUN. Effectively these troubles are triggered by the combined information available locally into a unit and the Unit\_Info . These last exception is applicable exclusively to “Insufficient Propulsion” trouble and “Brake Fault” trouble.

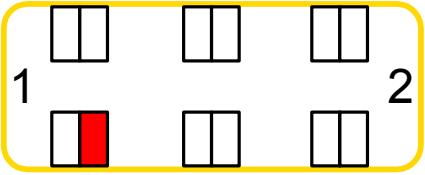
#### 4.3.2.2 Trouble marker scheme

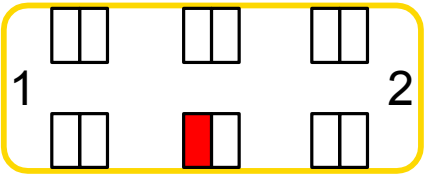
The marker scheme describes how the trouble information is to be displayed in the graphical representation of the train on the Trouble screen. The two highest bits of the MSB are used as spare and set at “0” and the remaining bits used to define the sixteen (16) possible positions as shown as following:

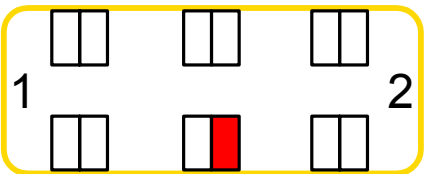
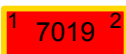
| Binary Location ID             | Location                         | Representation <sup>2</sup>  |
|--------------------------------|----------------------------------|--|
| MSB 0000,0000<br>LSB 0000,0000 | No marking                       | (Not applicable)   |
| 0000,0000<br>0000,0001         | End 1                            |   |
| 0000,0000<br>0000,0010         | End 2                            |   |
| 0000,0000<br>0000,0011         | Whole Car                        |   |
| 0000,0000<br>0000,0111         | Left<br>Panel #1<br>(doors only) | <br>supplemented in the additional information screen area with :<br>     |
| 0000,0000<br>0000,1011         | Left<br>Panel #2<br>(doors only) | <br>supplemented in the additional information screen area with :<br>   |
| 0000,0000<br>0001,0011         | Left<br>Panel #3<br>(doors only) | <br>supplemented in the additional information screen area with :<br> |
| 0000,0000<br>0010,0011         | Left<br>Panel #4<br>(doors only) | <br>supplemented in the additional information screen area with :<br> |
| 0000,0000<br>0100,0011         | Left<br>Panel #5<br>(doors only) | <br>supplemented in the additional information screen area with :   |

<sup>2</sup> Refer to Trouble Screen images presented in Appendix for complete layout.

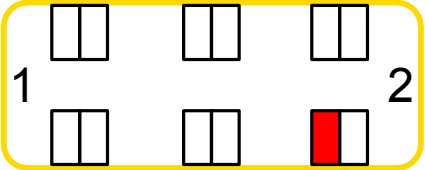
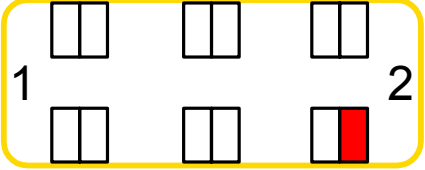
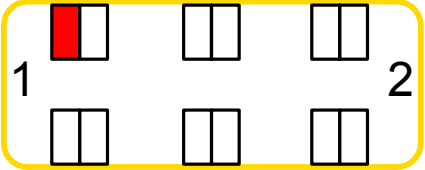
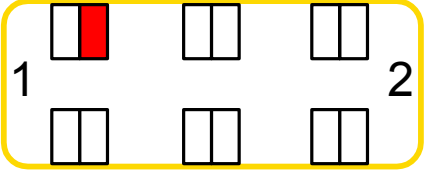
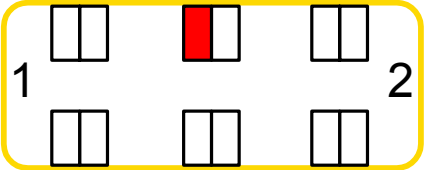
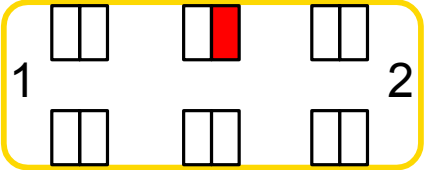
| Binary Location ID     | Location                          | Representation <sup>2</sup>  |
|------------------------|-----------------------------------|--|
|                        |                                   |    |
| 0000,0000<br>1000,0011 | Left<br>Panel #6<br>(doors only)  | <p style="text-align: center;"><b>1 7019 2</b></p> <p>supplemented in the additional information screen area with :</p>    |
| 0000,0001<br>0000,0011 | Right<br>Panel #1<br>(doors only) | <p style="text-align: center;"><b>1 7019 2</b></p> <p>supplemented in the additional information screen area with :</p>   |
| 0000,0010<br>0000,0011 | Right<br>Panel #2<br>(doors only) | <p style="text-align: center;"><b>1 7019 2</b></p> <p>supplemented in the additional information screen area with :</p>  |
| 0000,0100<br>0000,0011 | Right<br>Panel #3<br>(doors only) | <p style="text-align: center;"><b>1 7019 2</b></p> <p>supplemented in the additional information screen area with :</p>  |
| 0000,1000<br>0000,0011 | Right<br>Panel #4<br>(doors only) | <p style="text-align: center;"><b>1 7019 2</b></p> <p>supplemented in the additional information screen area with :</p>  |

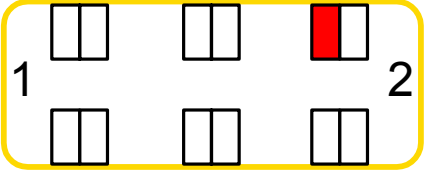
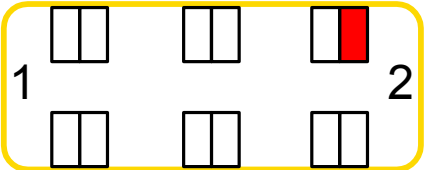
| Binary Location ID     | Location                       | Representation <sup>2</sup>  |
|------------------------|--------------------------------|--|
| 0001,0000<br>0000,0011 | Right Panel #5<br>(doors only) | <p style="text-align: center;"><b>1 7019 2</b></p> <p style="text-align: center;">supplemented in the additional information screen area with :</p>  |
| 0010,0000<br>0000,0011 | Right Panel #6<br>(doors only) | <p style="text-align: center;"><b>1 7019 2</b></p> <p style="text-align: center;">supplemented in the additional information screen area with :</p>  |

#### 4.3.3 TRAIN FUNCTIONS - OBJECT 3 AND 4

Some momentary train functions are transmitted train wide via the IUN. This information is received from the other unit via the *nvi03Function* network variable and, similarly, is sent to the other unit through the *nvo04Function*. These variables are presented respectively within node object 3 and 4. These variables contain the *struct\_train\_function* which is presented below.

```
typedef struct {
    int                iFunctionID;    //ID of the function                1 byte
    unsigned short    uSpare;         //Spare                               1 byte
} struct_train_function;              //                                     Total size of : 2 bytes
```

siFunctionID : This field indicates the code of the function to be carried out.

uSpare : Reserved one (1) byte data buffer for future use.

When the IUNG detects that a train function must be carried out, it transmits the corresponding function ID to the other unit. Upon reception of the function, the IUNG evaluates which function is addressed and then carries it out in an appropriate manner within its unit.

Defined Train Functions

| Code | Function ID           | Description  |
|------|-----------------------|--|
| 1    | LIGHT_ON              | Request to turn ON the lighting system in the train  |
| 2    | LIGHT_OFF             | Request to turn OFF the lighting system in the train   |
| 3    | TROUBLE_LIST_REQUEST  | Request for the other unit's Local Unit Trouble list transfer.   |
| 4    | MDS_TIME_REQUEST      | Request for an MDS Time update   |
| 5    | DISPLAY_TIME_REQUEST  | Request for an Display Time update<br>the same train side as the active....  |
| 6    | DOOR_PARTIAL_CLOSE_R  | Request a partial close for the doors located on the same train side as the active (Zone-in) Master Door Controller Right (see section 4.3.1.2 Structure A_Car   |
| 7    | DOOR_PARTIAL_CLOSE_L  | Request a partial close for the doors located on the same train side as the active (Zone-in) Master Door Controller Left (see section 4.3.1.2 Structure A_Car    |
| 8    | DOOR_LOCAL_RECYCLE_R  | Request a local recycle for the doors located on the same train side as the active (Zone-in) Master Door Controller Right (see section 4.3.1.2 Structure A_Car   |
| 9    | DOOR_LOCAL_RECYCLE_L  | Request a local recycle for the doors located on the same train side as the active (Zone-in) Master Door Controller Left (see section 4.3.1.2 Structure A_Car    |
| 10   | HVAC_ON               | Reserved for R142A Train   |
| 11   | DOOR_OPEN_CMD_R       | Request an Open Command for the doors located on the same train side as the active (Zone-in) Master Door Controller Right (see section 4.3.1.2 Structure A_Car). |
| 12   | DOOR_OPEN_CMD_L       | Request an Open Command for the doors located on the same train side as the active (Zone-in) Master Door Controller Left (see section 4.3.1.2 Structure A_Car).  |
| 13   | ODOMETER_INFO_REQUEST | Request for the other unit's Local Unit struct_odometer_info transfer.   |

#### 4.3.3.1 Identification of the Open Command Requesting MDC

In order to determine which side of the train the Door system will perform the requested Network commands, the Inter-Unit network Gateway shall behave as described below:

The IUNG shall transmit the nvo04Function each time the open button is depressed and when the MDC is zone-in. The data value shall be set as described in the following tables. The transmission of nvo04Function on IUN shall be done into a maximum of 1 second after the open button depression.

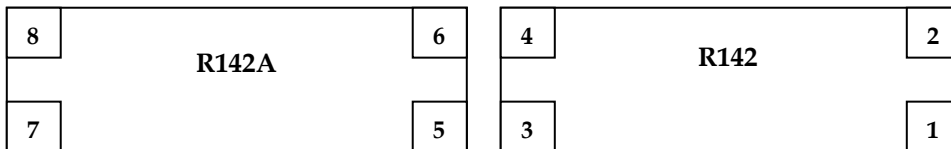

| MDC5 (R) |                   |                  |                     | MDC6 (L) |                   |                  |                     |
|----------|-------------------|------------------|---------------------|----------|-------------------|------------------|---------------------|
| Case #   | Open Right button | Open Left button | nvo04Function Value | Case #   | Open Right button | Open Left button | nvo04Function Value |
| 1        | 0                 | 0                | ≠ 11 or 12          | 1        | 0                 | 0                | ≠ 11 or 12          |
| 2        | 0                 | 1                | =11                 | 2        | 0                 | 1                | ≠ 11 or 12          |
| 3        | 1                 | 0                | ≠ 11 or 12          | 3        | 1                 | 0                | =12                 |
| 4        | 1                 | 1                | =11                 | 4        | 1                 | 1                | =12                 |

| MDC7 (L) |                   |                  |                     | MDC8 (R) |                   |                  |                     |
|----------|-------------------|------------------|---------------------|----------|-------------------|------------------|---------------------|
| Case #   | Open Right button | Open Left button | nvo04Function Value | Case #   | Open Right button | Open Left button | nvo04Function Value |
| 1        | 0                 | 0                | ≠ 11 or 12          | 1        | 0                 | 0                | ≠ 11 or 12          |
| 2        | 0                 | 1                | =12                 | 2        | 0                 | 1                | ≠ 11 or 12          |
| 3        | 1                 | 0                | ≠ 11 or 12          | 3        | 1                 | 0                | =11                 |
| 4        | 1                 | 1                | =12                 | 4        | 1                 | 1                | =11                 |

#### 4.3.4 DISPLAY TIME - OBJECT 5 AND 6

An button is present on the *Operating Screen* to give access to *the Display Time Setup* screen. Once selected, the *Display Time Setup* screen is presented. This screen enables the operator to enter the display time. Refer to proposed screen image (SCR-C30) presented in Appendix. The “DAYS” button allow to phase the date with the current time modification. When the days up arrow is pressed, the sign “+” appear in the middle square field under the arrow and the user need to press accept time button to increase by one the date value. Inversely, the days down arrow will cause a sign “-“ apparition and will decrease de date value by one when the accept time button will pressed. The date can be changed only by one day at once by the accept time command. If the up arrow is depressed several time the sign displayed in the middle square field under the arrow will change from space “”, to plus “+”, to minus “-“.

When the operator selects the “ACCEPT TIME” button, the display time information is broadcast to the entire train for all systems to be synchronized, as required. The display time is then maintained locally in each Unit of the train.

At any time, an operator may change the display time from any active cab in the train : the last accepted time will be maintained as the current display time.

When coupled, the IUNG of each unit will transmit the Display Time to the other unit using *nvo06DisplayTime* on the following conditions:

- Display time changed locally using the Display Time Setup screen;
- On request using the Train Function objects (DISPLAY\_TIME\_REQUEST).

At Unit power-up, the MDS time and the display time are the identical (no difference) until the required synchronization information is entered by the user and exchanged between Units, as described above.

When the coupler status will change from uncoupled to coupled, the R142 IUNG only will transmit the Display Time variable to the R142A IUNG.

#### 4.3.5 MDS TIME - OBJECT 7 AND 8

Whenever the MDS time is change in a Unit, it must be sent to the other Unit. This is done using object 7 and 8. Object 7 is used to receive the time change from the other Unit and object 8 is used to send a local time change.

When coupled, the IUNG of each unit will transmit its own MDS time to the other unit using *nvo08MDSTime* on the following conditions:

- Coupler status changed from uncoupled to coupled;
- Units powered up while coupled;
- MDS time change through PTE while coupled;
- On request using the Train Function objects (MDS\_TIME\_REQUEST).

This MDS Time exchange will enable each of the Units to keep logs of MDS Time delta between them for possible event log correlation.

#### 4.3.6 ODOMETER INFO – OBJECT 9

The odometer information will regroup all data pertinent to the actual car mileage value of each cars of a unit. This information will be used to display the odometer values of the other unit on the Operating screen to fulfill the NOPCO .

This information will be received from the other unit through the *nvi09OdometerInfo* input network variable. Similarly, the data of the current unit will be sent to the other unit via the *nvo09Odometer* output variable. Both of these variable are presented within Node Object #9. These variables will contain data structures with all relevant information.

The *nvi09OdometerI* network variable will be propagated from the node immediately upon any value updates within the structure or after the MaxSndTime timer as expired. This network variable shall never be emitted on a period shorter than the nci09MinSendT value.

##### 4.3.6.1 Structure Odometer\_Info

The following data structure, defined as *struct\_odometer\_info*, will be used :

```
typedef struct {
    short int          siNum_Car;          //Indicated how many cars are in the unit 1 byte

    struct_Odom_car   List_Odom_Car[6]; //List of structures containing the odometer
                                                // value and the car ID of the cars of a unit      30 bytes
} struct_odometer_info;                // Total size of : 31 bytes
```

siNum\_Car : This field provides information about the number of cars contained within the unit. It indicates the number of element contained within the *List\_Odom\_Car* field.

List\_Odom\_Car : List of elements representing each car present in the unit. The list length is given by the *siNum\_Car* field. The first element in the list correspond to the coupled A Car odometer information. The element correspond to the “B” car physically connected to the coupled “A” car of the unit. The following element corresponds to the next physically connected “B” car. The last element (always 6<sup>TH</sup> element) of the list correspond to the un-coupled “A” car of the unit. In the case where the unit contain 5 cars the 5<sup>TH</sup> element of the list shall filed with “0”. If only 4 cars are present in the unit, the 5<sup>TH</sup> and 4<sup>TH</sup> elements of the list shall filed with “0”. The complete description of the *struct\_Odom\_Car* data structure is given below.

#### 4.3.6.2 Structure Odom\_Car

The data containing the odometer information each cars of the unit. The following data structure, defined as *struct\_odom\_car*, will be used

|                    |              |   |                         |
|--------------------|--------------|---|-------------------------|
| typedef struct {   |              |   |                         |
| long               | liCarID;     | //Car ID. The sign indicates the orientation relative to the coupled A car ( + for direct, - for reverse) | 2 bytes                 |
| unsigned           | uMileage[3]; | //Odometer value in hexadecimal   | 3 bytes                 |
| } struct_odom_car; |              | //  | Total size of : 5 bytes |

liCarID : This field will provide the CAR ID information of the car. It will also indicate the orientation of the car relative to the coupled "A" car of the unit. The orientation is termed forward when the end 1 of the car is closer to the coupled "A" car of the unit. This condition will be indicated as a positive CAR ID value. The orientation is termed reverse when the end 2 of the car is closer to the coupled "A" car of the unit. This condition will be indicated as a negative CAR ID value. If the CAR ID is undetermined, a zero (0) value shall be used.

uMileage : This field will provide the odometer value of the associated car in hexadecimal format. The first element of uMileage shall represent the highest portion of the odometer value, the second element shall represent the middle portion and the last element shall provide the lowest portion of the mileage value. So an odometer value of 89643 miles, the first byte should be set to 01 Hex the second should be set to 5E Hex and the last should be set to 2B Hex. Note that each unit represent one mile and the data range shall be between 0 to 98967F Hex (0 to 9999999 decimal). If the odometer value exceed the maximum range value, it shall be reset to zero.

## 4.4 NODE INSTALLATION

Because of the dedicated nature of the IUN, and the fact that a maximum of two nodes will present on the network, the self-installed method will be used to configure the IUNG.

To simplify the installation and management, pre-assigned addresses will be given to R142 and R142A units. The addresses for the first Domain Table will be assigned in the following manner :

- Domain length : 1
- Domain ID : 142
- Subnet ID : 1
- Node ID for R142 unit : 1
- Node ID for R142A unit : 2

The second Domain Table will be assigned in the following manner :

- Domain length : 0
- Domain ID : na
- Subnet ID : na
- Node ID for R142 unit : na
- Node ID for R142A unit : na

Unique and constant PROGRAM ID will also be assigned to R142 and R142A IUNG application, respectively.

The Unicast addressing (same as subnet node addressing) mode will be used and in order to provide enhanced error detection and management, acknowledge services will be used for all messages. The number of retry will set at 3. The transaction timer “Xmit\_Timer”, “Repeat\_Interval\_Timer” and “Rcv\_Timer” will adjusted following some measurements on the IUN as recommended by the LonTalk Protocol Specification section 8.11.

#### 4.4.1 POWER-UP GUIDELINES

1. At the initial state, the IUNG will continuously broadcast its service pin message at a regular interval (preliminary interval set at 10 seconds).
2. This action will be repeated until the IUNG receives the other unit’s IUNG service pin message.
3. On reception of the other unit’s service pin message, the IUNG will acknowledge by immediately emitting its own service pin message.
4. Using the PROGRAM ID present in the other unit’s service pin message, the IUNG will determined that it is connected to a R142 or a R142A unit.
5. In the case that a R142 unit is coupled to a R142A unit, the IUNG will install its Domain Table, NV Table and Address Table according to pre-assigned values. Only the Domain table is determined at this time, as per section 0.
6. After completion of the self-installation, the IUNG application is executed to support revenue service operation.
7. If the nci01MaxReceiveT for the input of Unit Info object (Object 1) of the IUNG Node expires (refer to section 4.2.2), the node reverts back to step 1.

Note: The longest time to exchange information between R142 and R142A unit after the electrical coupling will be equal to the "service pin broadcast" period (step #1 above) plus the Transmission time (Transmission time = Typical media access time of 48 bits + 10 bytes header + Packet length at 78.125KHz + Internal processing time). Roughly, this time will turn around 10 to eleven seconds.

During the set-up time the TOD will display the car arrangement previously shown before the coupling sequence until the unit info is completely received and processed.

#### 4.4.2 R142 NODE’S PROGRAM ID

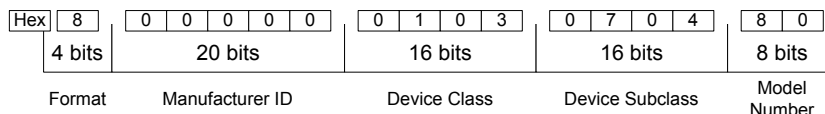

The PROGRAM ID field of the node is an 8 byte identifier that shall have the following format:

The corresponding Neuron® “C” source code declaration shall be :

```
#pragma set_std_prog_id 80:00:00:01:03:07:04:80
```

#### 4.4.3 R142A NODE'S PROGRAM ID

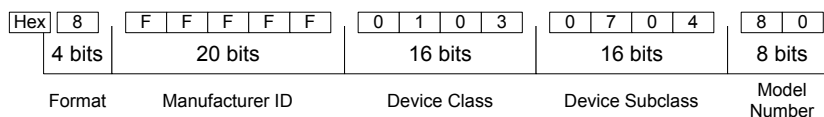

The PROGRAM ID field of the node is an 8 byte identifier that shall have the following format:

The corresponding Neuron® “C” source code declaration shall be :

```
#pragma set_std_prog_id 80:FF:FF:F1:03:07:04:80
```

#### 4.5 AUDIBLE ALARMS

To provide the audible alarms, the MDL modulate a piezo audio indicator generating a continuous tone at 1800 Hz.

##### 4.5.1 PARKING BRAKE WITH TRAIN IN MOTION

When the “Stuck brake *Trouble*” is active, the MDL also needs to activate its internal buzzer with a continuous tone to provide a recognizable audible alarm to the operator. The audible alarm will shut-off when the acknowledge button will be depressed on the Operating Screen.

##### 4.5.2 PEHU

When the trouble “Brake in Emergency - PEHU” is active, the MDL will need to active its internal buzzer with a one second ON one second OFF tone sequence to provide an recognizable PEHU audible alarm to the operator. The audible alarm will shut-off when the acknowledge button will be depressed on the Operating Screen.

##### 4.5.3 DIRECTION SET TO REVERSE

It is already required that the direction indication be displayed on the Operating screen. When the direction is set to reverse, the MDL will active its internal buzzer with a two second ON one second OFF tone sequence to indicate to the operator that the direction is currently set to reverse. The audible alarm will shut-off when the direction will be set to forward.

##### 4.5.4 PEI INDICATION

The PEI activation information will be supplied by the CMC of each car. It will be displayed as a Trouble on the Trouble Screen.

##### 4.5.5 SPARE AUDIBLE ALARM

Two spare audible alarms are reserved for future use. The duty cycle will be defined when these alarms will be necessary.

#### 4.6 DATA FORMAT

All the information issued by the MBS and sent through the car network shall be formatted following the Motorola usual format Big Endian,

Bit 0 is the Least Significant Bit of the Least Significant Byte

Byte[0] is the Most Significant Byte and correspond to address offset 0

Organization of data formats in memory is consistent with the M68000 family data organization and Neuron™ data organization

A “short” is an 8 bits variable as per Neuron definition

A “long” is a 16 bits variable as per Neuron definition

Bit fields are of the type “unsigned char” which correspond to an “unsigned short” (8-bit) as per Neuron C. Therefore, all bit-fields definitions must comply with the following rules:

- maximum 8 bits
- do not cross byte boundaries
- defined as “unsigned char” (for compiler independence)

Note: Supplier developing host application shall use a compiler supporting the “unsigned char” variable type for bitfield definitions.

For example, a four (4) bytes variable will be arranged as follows:

| BYTE[0]<br>(Base address + 0) | BYTE[1]<br>(Base address + 1) | BYTE[2]<br>(Base address + 2) | BYTE[3]<br>(Base address + 3) |
|-------------------------------|-------------------------------|-------------------------------|-------------------------------|
| 31                            | 24                            | 16                            | 8                             |
| 0                             | 0                             | 0                             | 0                             |

An example of a bit field structure in Neuron C for this variable would be as follows:

```
{
unsigned char bit31          : 1;    // offset 0x00
unsigned char bit30_29      : 2;
unsigned char bit28_24      : 5;
unsigned char bit23_18      : 6;    // offset 0x01
unsigned char bit17_16      : 2;
unsigned char bit15_12      : 4;    // offset 0x02
unsigned char bit11_8        : 4;
unsigned char bit7_3         : 5;    // offset 0x03
unsigned char bit2_0         : 3;
} ExampleStruct;
```

Notes:

Platforms using the Little Endian convention must take precaution to reverse the byte ordering when using 16 bits values, and to reverse the order of bitfields declarations in structures.

#### 4.7 TRAFFIC CONSIDERATION

The information sent on IUN pass through two TMX before to be received by the other IUNG. On IUNG point of view the TMX behavior as an Echelon router configured in repeater but there is one difference between this equipment and a true Echelon router it is the limited throughput of the TMX. The maximum throughput of the TMX is:

| Data Packet length | Number of Packet/second |
|--------------------|-------------------------|
| 1 byte             | 106 Pkt/s               |
| 32 bytes           | 75 Pkt/s                |

#### 4.8 IUNG RESPONSE TIME

The present response time analysis result take in account the maximum delay the IUNG could cause in the case were several network functions are performed by these last. A typical response time value will turn around 100 ms.

##### Worst case IUNG message transmission times

|   |  |
|---|--|
| <b>Worst case IUNG transmission delay</b>   | <b>1 s from R142 local network to TMS LonWorks® interface</b>  |
| <b>Overall TMS retransmission delay</b>     | <b>35ms (maximum allowed delay) between the TMS LonWorks® interface and the E1 multiplexed trainline</b> |
| <b>Total INUG message transmission time</b> | <b>1.035 ms between local A car network and the E1 multiplexed trainline</b>                             |

## 5. APPENDIX

### 5.1 APPENDIX 8 : TOD SCREENS

- TOD SCREENS FLOWCHART
- GENERAL DESCRIPTION
- OPERATING SCREEN (SCR-A30)
- ROUTE AND DESTINATION SETUP
  - Route Pre-Selection Screen (SCR-B30)
  - Route Selection Screen (SCR-C30)
  - Stopping Pattern Selection Screen (SCR-D30)
- TROUBLE SCREEN WITH BRAKE TROUBLE (SCR-A20)
- TROUBLE SCREEN WITH DOOR TROUBLE (SCR-A20)

5.1.1 TOD SCREENS FLOWCHART

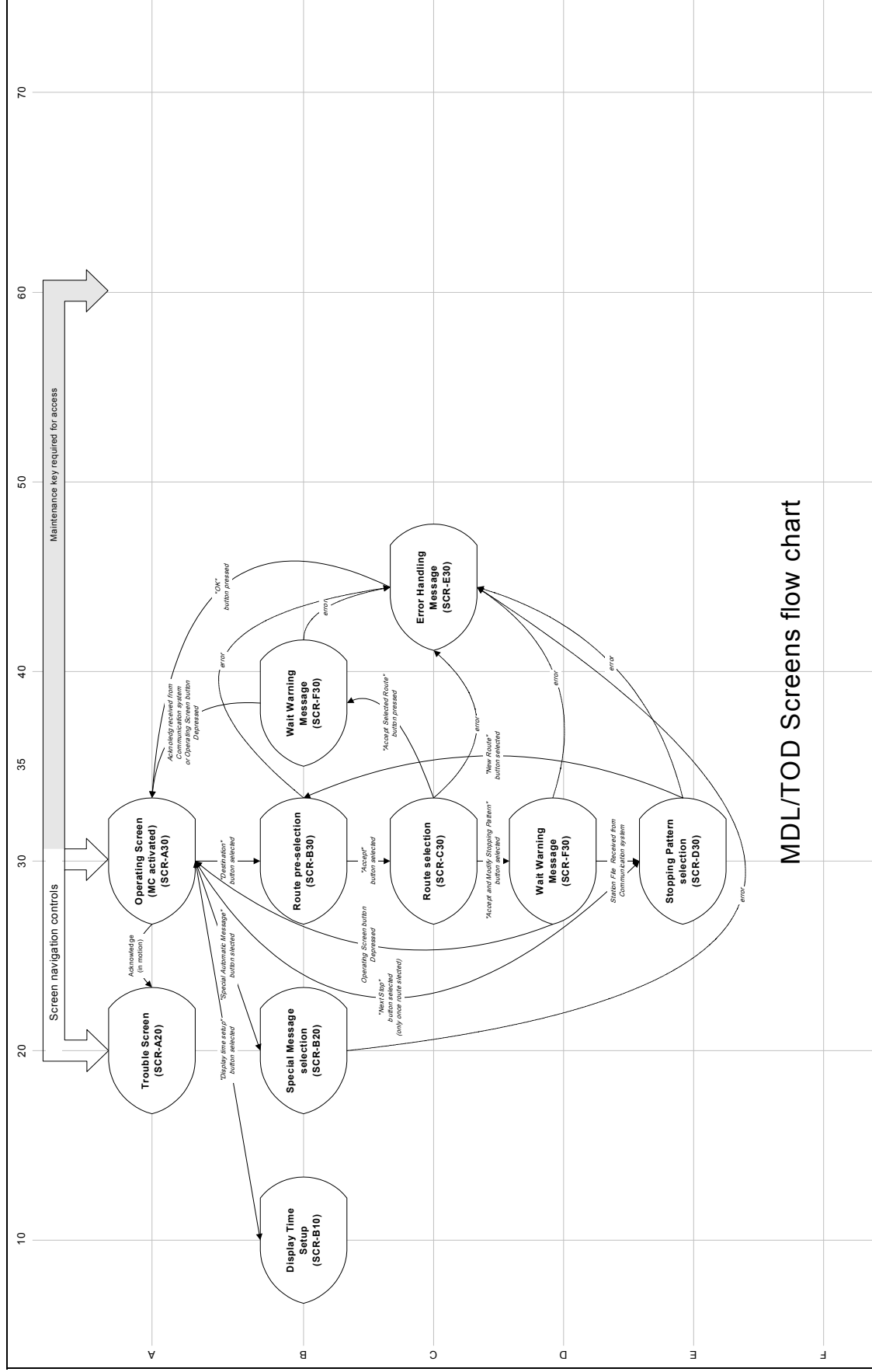

MDL/TOD Screens flow chart

### 5.1.2 GENERAL DESCRIPTION

All screens are composed of three main sections or areas :

1. Header;
2. Information area;
3. Navigation.

The header is composed of the date (top left), the screen title (top center), the time (top right) and the current consist information (below). The consist represent the physical layout of the current train. Each car is represented by a rectangular shape which contains the car id (center), the orientation information (“1” and “2” symbols at top of car), and an odometer (over the car). The cab cars are represented by a gray rectangle located at end 1. When the cab is active (MC or MDC keys) a green rectangle indicates which key is currently used. This is indicated by a green rectangle within the gray rectangle of the cab representation. The top and bottom rectangle represent a MDC key (refer to car 7121 in current example). The center rectangle represent the MC key (refer to car 7222 in current example). The consist will always be represented with the head of the train (active MC cab) at the right of the screen. A green triangular arrow indicate the direction of the train as set by the MC key position. When the train is set to reverse, the arrow will be display at the extreme left of the consist (tail end).

The information area contains all information relevant to the currently displayed screen.

The bottom of the screen contains the screen navigation area. All active buttons (or other selectable screen areas when applicable) will be framed by a thick green line with the button text in black. For buttons, the background (fill) is always white. For other selectable screen area, the background is transparent. The text background is always white. When a button is not currently selectable for any reasons, it will appear with a “grayed” border and text. (refer to second button from the left in the current example). When a button is selected, it will appear in reverse video (white text over a black background) to

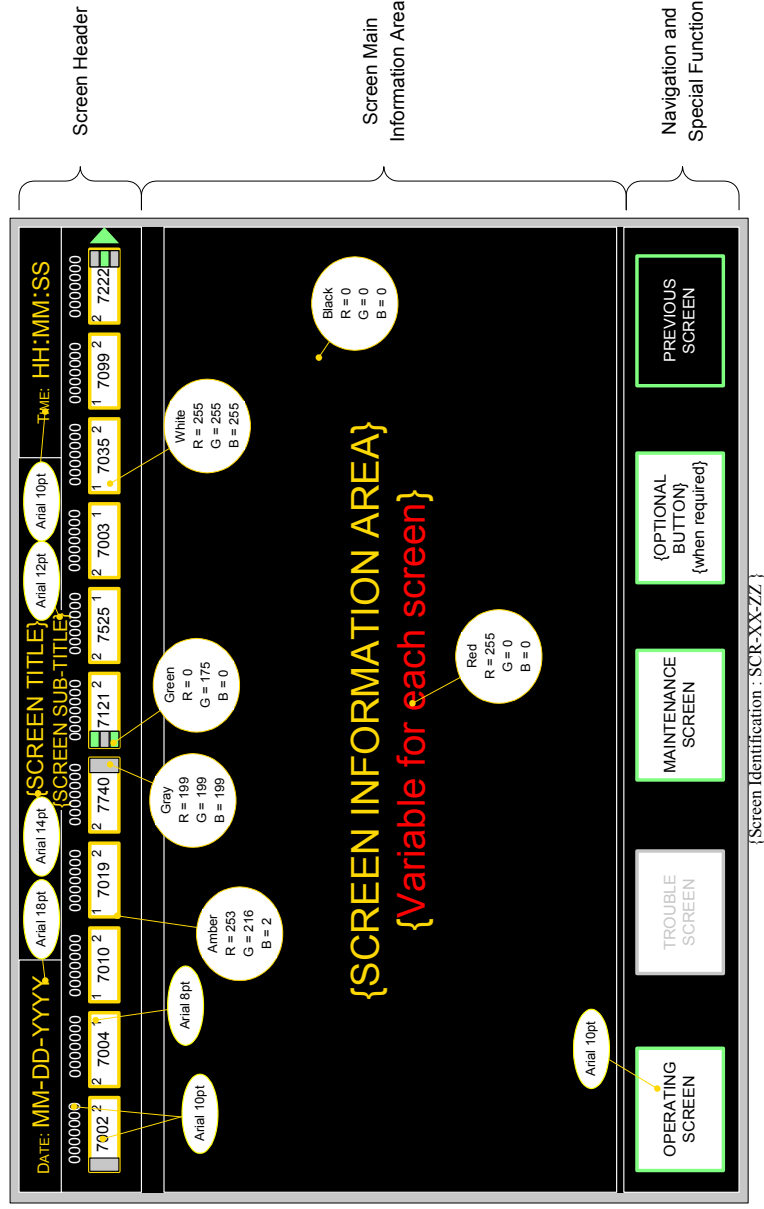

indicated that the requested action is initiated (refer to extreme right button for example). Upon completion of the command, the button will go back to its normal state.

The “OPERATING SCREEN” button (first button from the left) is always available except when the Operating Screen is displayed or when the AAS setting error handling screen is displayed. Upon selection of the button, the Operating Screen will immediately be displayed. The “TROUBLE SCREEN” button (second button from the left) behave in similar manner except for the fact that it will display the Trouble Screen. The “MAINTENANCE SCREEN” button (third button from the left) will be selectable only when a maintenance key is detected in the current cab. The “PREVIOUS SCREEN” button (far right) is always available except immediately after power-up, when the Route Pre-Selection Screen or the Route Selection Screen or The Stopping Pattern Selection Screen or the Special Message Selection Screen is displayed and upon existing from a Maintenance Screen by removal of the maintenance key . When activated, it will recall the previously displayed screen. The recall buffer contains only one entry. This means that if it is press repeatedly, it will toggle between the same two displayed screens (current and previous).

The fourth button from the left, showed as the “OPTIONAL BUTTON” may or may not be displayed, depending on the screen. The text in the button will indicate its purpose when it is available.

When the TOD is first activated, either just after power-up or upon reception of one of the key signals (MC, MDC or Maintenance), the Operating screen will be displayed..

In order to provide useful progress or error information to the operator, a popup message box will displayed, as necessary it the center of the screen. The message box will contain a title and some information text appropriate to the event. The operator will be able to dismiss the box by simply touching it.

Note: The Helvetica font could be use instead of the Arial font they are seamless

5.1.3 OPERATING SCREEN (SCR-A30)

The screenshot displays the 'OPERATING SCREEN' with the following elements:

- DATE:** 03-21-1998
- TIME:** 16:45:23
- Cardiac/Brake Status:** A row of 12 indicator boxes, each with a '1' and '2' position. The first four boxes (7002, 7004, 7010, 7019) show a green bar. The fifth box (7121) shows a green bar with a red segment. The sixth box (7740) shows a green bar. The remaining six boxes (7003, 7035, 7099, 7222, 7525, 7000) are empty.
- Interval:** INTERVAL : 0855
- Stop Locations:**
  - PREVIOUS STOP:** 116th Street
  - NEXT STOP:** 125th STREET
  - DESTINATION:** 5 to FLATBUSH AV. via 7 AV. EXPRESS BROOKLYN EXPRESS
- Distance:** DISTANCE 1 050 ft
- System Status:** SNOW BRAKE ON
- Control Buttons:**
  - REGENERATIVE BRAKE CUTOFF
  - DOOR INTERLOCK BYPASS
  - BRAKE INTERLOCK BYPASS
  - ELECTRONIC STRIP MAP OFF
  - AUTOMATIC MESSAGES OFF
- Navigation/Menu Buttons:**
  - DISPLAY TIME SETUP
  - OPERATING SCREEN
  - TROUBLE SCREEN
  - MAINTENANCE SCREEN
  - ACKNOWLEDGE
  - SPECIAL AUTOMATIC MESSAGES
  - PREVIOUS SCREEN

Callouts indicate font specifications: Arial 18pt for 'PREVIOUS STOP', 'NEXT STOP', and 'DESTINATION'; Arial 14pt bold for '116th Street'; Arial 12pt for 'SNOW BRAKE ON' and the '5' in the destination; and Arial 44pt for the '5' in the destination.

SCR-A30

The screen information area of the *Operating Screen* is divided in three sub-sections : the sign information at the top, the status indication section in the middle and the “ACKNOWLEDGE” button at the bottom.

The “DESTINATION” indication itself acts as a button. When selected, the button will bring up the *Route Pre-Selection* screen. Once a valid route is selected an accepted, the “NEXT STOP” indication will also become a selectable button. Upon selection of this control, the *Stopping Pattern Selection* screen is called up. When the “NEXT STOP” is not selectable, it is outlined with a thin white line like the “PREVIOUS STOP” indication. When it is selectable, it is outlined by a thick green line (as displayed in the example). Initially (no route selected), all signs indications are empty (black). Once a valid Route and Destination is selected through the appropriate screens, the “DESTINATION” and “NEXT STOP” information are displayed. Once the first station stop is completed, a new “NEXT STOP” text is displayed corresponding to the next station on the stopping pattern. At this point, the old “NEXT STOP” text is moved to the “PREVIOUS STOP” indication.

The status indication section provides useful status information to the train operator. The location, color and text of these indications are fixed. The indications are only visible when active. They act as “back-lighted” indicators that are invisible when not active. In this area, we have the “SNOW BRAKE”, “REGENERATIVE BRAKE CUTOUT”, “DOOR BYPASS”, “BRAKE BYPASS”, “ELECTRONIC STRIP MAP OFF” and “AUTOMATIC MESSAGES OFF” indications.

The “ACKNOWLEDGE” button is normally inactive, which means grayed-out. When a new trouble occurs, as detected by the MDL/TOD internal logic, the button will become active. When active the button will “flash” at a regular interval of 1 second : the text and border will by red with a white background for ½ second and will then change to white text and border with a red background for the other ½ second. When selected by the operator, the Trouble Screen is displayed.

Finally, the optional button within the navigation area is used in this screen. When selected this button gives access to the *Special Message Selection* screen.

OPERATION SCREEN DESCRIPTION TABLE

| Row | OPERATING ITEMS          | SCREEN TYPE               | UPDATED WHEN:   | STATUS WHEN NO ROUTE IS SELECTED   | SPECIFIC DETAILS  | TEXT ATTRIBUTES & COMMENTS  |
|-----|--------------------------|---------------------------|---|--|---|---|
| 1   | INFORMATION SIGN SECTION |                           |   |  |   |   |
| 2   | INTERVAL                 | Field                     | Upon <i>Accept Selection</i> button activation in Route Pre-selection screen          | Blank, unless the interval ID is accepted  |   | The text shall be displayed as follows: <ul style="list-style-type: none"> <li>• amber character on black background</li> <li>• Arial 18 pts</li> <li>• center alignment</li> </ul>   |
| 3   | PREVIOUS STOP            | Field                     | When AAS change the <i>Next Stop</i> field information.                               | Blank  |   | The text shall be displayed as follows: <ul style="list-style-type: none"> <li>• white character on black background</li> <li>• Arial 14 pts bold (for field)</li> <li>• Arial 18 Pts (for title)</li> <li>• Center alignment</li> </ul>                  |
| 4   | NEXT STOP                | Field                     | When AAS increment its  | Blank.   | This field is cleared when no route is selected and when the train is still at the first station.<br>This field is limited to 20 characters<br>This field is limited to 20 characters | The text shall be displayed as follows: <ul style="list-style-type: none"> <li>• white character on black background</li> <li>• Arial 14 pts bold</li> <li>• center alignment</li> </ul>  |
| 5   |                          | Button                    | n/a   | This button is inactive when no route is selected. In this case, the NEXT STOP is outlined with a thin white line. | If no route was selected, the button shall be inactive. In case of AAS re-synchronization event, the button shall remain active even though the text is cleared.                      | The text shall be displayed as follows: <ul style="list-style-type: none"> <li>• white character on black background</li> <li>• Arial 18 pts (for title)</li> <li>• center alignment</li> </ul>   |
| 6   | DESTINATION              | Field<br>"ROUTE ID"       |   | Blank.   |   | <u>Shape:</u><br>Diamond: Height is 54 and length is 54<br>Circle: Diameter is 50<br><u>Fill Color background:</u> color will be either green, amber or red (color attribute provided in message)<br><u>Route ID:</u><br>Arial 44pts with blackbackground |
| 7   |                          | Field<br>"remaining text" | When the operator depress one of the following buttons in the Route Selection Screen: | Blank  | This field shall have a maximum of three (3) lines of 20 characters.  | The text shall be displayed as follows: <ul style="list-style-type: none"> <li>• white character on black background</li> <li>• Arial 12 pts bold</li> <li>• Left alignment</li> </ul>  |

| Row | OPERATING ITEMS            | SCREEN TYPE | UPDATED WHEN:   | STATUS WHEN NO ROUTE IS SELECTED | SPECIFIC DETAILS  | TEXT ATTRIBUTES & COMMENTS   |
|-----|----------------------------|-------------|---|----------------------------------|---|--|
| 8   |                            | Button      | <ul style="list-style-type: none"> <li>Accept Selected Route</li> <li>Accept and Modify Stopping Pattern</li> </ul> | This button is always active.    | The TOD will clear this field when a route change will be requested by the user.  | <ul style="list-style-type: none"> <li>The text shall be displayed as follows: <ul style="list-style-type: none"> <li>white character on black background</li> <li>Arial 18 pts (for title)</li> <li>Center alignment</li> </ul> </li> </ul>   |
| 9   | DISTANCE                   | Field       | Upon communication system distance update.  | Blank                            | This field is blank when the train is still at the first station.   | <ul style="list-style-type: none"> <li>The text shall be displayed as follows: <ul style="list-style-type: none"> <li>white character on black background</li> <li>Arial 14 pts bold (for field)</li> <li>Center alignment</li> <li>5 digits maximum (no “,” as separation)</li> </ul> </li> </ul> |
| 10  |                            |             | n/a   | Blank                            | The text “Ft” shall not be displayed when no route is selected or when the train is still at the first station.   | <ul style="list-style-type: none"> <li>The text shall be displayed as follows: <ul style="list-style-type: none"> <li>white character on black background</li> <li>Arial 14 pts bold (for field)</li> <li>After the field data value (one space between the field and text)</li> </ul> </li> </ul> |
| 11  | STATUS INDICATION SECTION  |             |   |                                  |   |  |
| 12  | ELECTRONIC STRIP MAP OFF   | Field       | When TOD receives the status  | Blank (including box line)       | This field is displayed only when the status of the ESM is OFF  | <ul style="list-style-type: none"> <li>The text shall be displayed as follows: <ul style="list-style-type: none"> <li>white character on black background</li> <li>Arial 12 pts (for field)</li> <li>Center alignment</li> </ul> </li> </ul>   |
| 13  | AUTOMATIC MESSAGES OFF     | Field       | When TOD receives the status  | Blank (including box line)       | When AAS re-synchronization occurs, the AAS status shall be automatically set to OFF.<br><br>This field is displayed only when the status of the AAS is OFF | <ul style="list-style-type: none"> <li>The text shall be displayed as follows: <ul style="list-style-type: none"> <li>white character on black background</li> <li>Arial 12 pts (for field)</li> <li>Center alignment</li> </ul> </li> </ul>   |
| 14  | SPECIAL AUTOMATIC MESSAGES | Button      | n/a   | Always present                   | None  | <ul style="list-style-type: none"> <li>The text shall be displayed as follows: <ul style="list-style-type: none"> <li>white character on black background</li> <li>Arial 10 pts (for field)</li> <li>Center alignment</li> </ul> </li> </ul>   |

| Row | OPERATING ITEMS    | SCREEN TYPE | UPDATED WHEN: | STATUS WHEN NO ROUTE IS SELECTED                | SPECIFIC DETAILS   | TEXT ATTRIBUTES & COMMENTS  |
|-----|--------------------|-------------|---------------|---|--|---|
| 15  | NAVIGATION SECTION |             |               |   |  |   |
| 16  | OPERATING SCREEN   | Button      | n/a           | Never active                                    |  | Arial 10 pts (for field)  |
| 17  | TROUBLE SCREEN     | Button      | n/a           | Always active                                   |  | Arial 10 pts (for field)<br>Black character on white background<br>When depressed:<br>White character on black background |
| 18  | MAINTENANCE SCREEN | Button      | n/a           | Always active                                   |  | Arial 10 pts (for field)<br>Box attributes:<br>Square box ...<br>Thin green line  |
| 19  | PREVIOUS SCREEN    | Button      | n/a           | Not related to the route (see specific details) | Not active if the previous screen was a dedicated AAS screen. Always active otherwise. | Arial 10 pts (for field)  |

5.1.4 ROUTE AND DESTINATION SETUP

5.1.4.1 Route Pre-Selection Screen (SCR-B30)

The screenshot displays the 'ROUTE PRE-SELECTION ROUTE AND DESTINATION SETUP' screen. At the top, it shows the date '03-21-1998' and time '16:45:23'. Below this, there are two rows of route numbers, each with '1' and '2' indicators and a small bar chart icon. The first row contains: 7002, 7004, 7010, 7019, 7740, 7121, 7525, 7003, 7035, 7099, 7222. The second row contains: 7002, 7004, 7010, 7019, 7740, 7121, 7525, 7003, 7035, 7099, 7222. The screen is divided into two main sections: 'LINE' and 'INTERVAL'. Each section has a numeric keypad (0-9) and 'UP'/'DOWN' arrow buttons. A callout points to the '0' button in the 'LINE' section, labeled 'Arial36pt Bold'. Below the numeric keypad is a large 'ACCEPT SELECTION' button. At the bottom, there are four buttons: 'OPERATING SCREEN', 'TROUBLE SCREEN', 'MAINTENANCE SCREEN', and 'PREVIOUS SCREEN'. A 'TURN ELECTRONIC STRIP MAP OFF' button is also present.

**DATE :** 03-21-1998 **TIME :** 16:45:23

**ROUTE PRE-SELECTION ROUTE AND DESTINATION SETUP**

1 7002 2 7004 1 7010 2 7019 2 7740 7121 2 7525 1 2 7003 1 7035 2 1 7099 2 2 7222

1 7002 2 7004 1 7010 2 7019 2 7740 7121 2 7525 1 2 7003 1 7035 2 1 7099 2 2 7222

**LINE**

UP 0 DOWN

UP 5 DOWN

**INTERVAL**

UP 0 DOWN

UP 5 DOWN

UP 8 DOWN

UP 5 DOWN

UP + DOWN

ACCEPT SELECTION

TURN ELECTRONIC STRIP MAP OFF

OPERATING SCREEN TROUBLE SCREEN MAINTENANCE SCREEN PREVIOUS SCREEN

SCR-C30

Arial36pt Bold

ROUTE PRE-SELECTION SCREEN DESCRIPTION TABLE

| Row | ROUTE PRE-SELECTION | SCREEN (SCR-B30)<br>TYPE          | UPDATED WHEN:  | STATUS WHEN NO ROUTE IS SELECTED  | SPECIFIC DETAILS   | TEXT ATTRIBUTES & COMMENTS   |
|-----|---------------------|-----------------------------------|--|---|--|--|
| 1   | LINE BOX            | DISPLAY BOX                       | n/a  | Always present  | None   | Characters:<br>Arial , 18 pts (for title)                                |
| 2   |                     | UP & DOWN arrows                  | n/a  | Always present and active   | Circular type selection.<br>1 <sup>st</sup> LINE ID arrows are not active because there is no Line with two digits in A division.  | Arial , 10 pts   |
| 3   | LINE ID             | Field (Single line with 2 fields) | When Arrow button is depressed. It keeps the user selection (only if Accept selection button is depressed) when navigating within the dedicated AAS screens. | The default value shall be displayed "01"   | Available selection:<br>Line ID:<br>First Digit: 0 (no other selection)<br>Second Digit: 1,2,3,4,5,6,7,8,9 and S<br><br>The TOD shall display the Line ID and Interval, as selected by the crew, using the field   | Character attributes:<br>Arial 36 pts, Bold<br>Black on white background |
| 4   | INTERVAL BOX        | DISPLAY BOX                       | n/a  | Always present  | None   | Characters:<br>Arial , 18 pts (for title)                                |
| 5   |                     | UP & DOWN arrows                  | n/a  | Always present and active   | None   | Arial , 10 pts   |
| 6   | INTERVAL SETTINGS   | Field (Single line with 5 fields) | When Arrow button is depressed. It keeps the user selection (only if Accept selection button is depressed) when navigating within the dedicated AAS screens. | The default value shall be displayed "0000 and blank" for the 5 <sup>th</sup> digit | Available selection:<br>INTERVAL ID:<br><br>The first 4 digits:<br>The available selection is based on valid Time entry:<br>from 00:00 to 23:59<br><br>If the user is trying to increase the first digit from 1 to 2 while the second digit is higher than 3, the TOD shall automatically set the second digit to "3". This will avoid invalid selection.<br><br>The 5 <sup>th</sup> digit : " " (blank), "+", and "-" | Character attributes:<br>Arial 36 pts, Bold<br>Black on white background |
| 7   | ACCEPT SELECTION    | Button                            | n/a  | Always active   | None   | Arial , 10 pts   |
| 8   | TURN ELECTRONIC     | Field                             | When TOD receives the  | TURN ELECTRONIC   | The ESM will be ON: by default when the route  | Arial , 10 pts   |

| Row | ROUTE PRE-SELECTION   | SCREEN (SCR-B30) TYPE | UPDATED WHEN:                                      | STATUS WHEN NO ROUTE IS SELECTED | SPECIFIC DETAILS  | TEXT ATTRIBUTES & COMMENTS |
|-----|-----------------------|-----------------------|--|----------------------------------|---|----------------------------|
| 9   | STRIP MAP ON (or OFF) | Button                | status change from the communication system<br>n/a | STRIP MAP OFF<br>Always active   | is selected. Therefore, the label will indicate Turn Electronic Strip Map OFF<br>None               |                            |
| 10  | NAVIGATION SECTION    |                       |  |                                  |   |                            |
| 11  | OPERATING SCREEN      | Button                | n/a  | Always active                    | If the user setting has not been accepted (Accept button depressed), the setting will be discarded. | Arial , 10 pts             |
| 12  | TROUBLE SCREEN        | Button                | n/a  | Never active                     | None  | Grayed                     |
| 13  | MAINTENANCE SCREEN    | Button                | n/a  | Never active                     | None  | Grayed                     |
| 14  | PREVIOUS SCREEN       | Button                | n/a  | Never active                     | None  | grayed                     |

5.1.4.2 Route Selection Screen (SCR-C30)

DATE : 03-21-1998

**ROUTE SELECTION**  
ROUTE AND DESTINATION SETUP

TIME : 16:45:23

7002 2

2 7004 1

1 7010 2

1 7019 2

2 7740

7121 2

2 7525 1

2 7003 1

1 7035 2

1 7099 2

2 7222

**AVAILABLE ROUTES**

| RT #  | ORIGIN        | DESTINATION | COMMENTS                      |
|-------|---------------|-------------|-------------------------------|
| 6     | 20            | 20          | 40                            |
| ***** |               |             |                               |
| ***** |               |             |                               |
| 2S001 | 241 St        | 241 St      | Cancel Route                  |
| 2N201 | Flatbush Av   | Flatbush Av | Train not in Service          |
| 2S001 | 241 St        | Flatbush Av | Flatbush Av 7 Av Exp          |
| 2N203 | Flatbush Av   | 241 St      | 7 Av Exp; Exp; Fkin-Atlan     |
| 4N002 | Utica Av      | Woodlawn    | via Lex Av Exp, 149 St-Nevins |
| 5S009 | New Lots Av   | Woodlawn    | via Bowling Grm 7 S Ferry     |
| 5N135 | Nereid Av     | Flatbush Av | Lex Exp, skips 138 St         |
| 5N101 | Utica Av      | Nereid Av   | Lex Lcl; Bklyn Lcl            |
| 5S003 | Bowling Green | Drye Av     | Bronx Exp, Lex Av Exp         |
|       | Drye Av       | Flatbush Av | Lex Exp, Bronx Exp            |
|       |               |             | Lex Lcl, Bronx Lcl            |
|       |               |             | via 7 Av Exp, 149 St-Nevins   |

ACCEPT  
SELECTED  
ROUTE

ACCEPT AND  
MODIFY  
STOPPING  
PATTERN

NEW ROUTE  
PRE-  
SELECTION

TURN  
ELECTRONIC  
STRIP MAP  
OFF

OPERATING  
SCREEN

TROUBLE  
SCREEN

MAINTENANCE  
SCREEN

PREVIOUS  
SCREEN

UP

DOWN

Arial12 pt

Arial10 pt

SCR-C30

Within the “AVAILABLE ROUTES” text box, there is 1 header row (Line, route, etc.) and exactly 10 lines of special messages visible at one time. The selected message is the one highlighted by the yellow bar in the white text box area. The “UP” and “DOWN” arrows at the bottom of the text box are used to scroll through the list of available messages. When scrolling, the text moves under the selection bar; the selection bar remains fixed within the text box. When the text is scrolled to the end of the list, the “DOWN” arrow is grayed out (inactive). Similarly, when the text is scrolled to the top of the list, the “UP” arrow is grayed out (inactive).

When the “ACCEPT SELECTED ROUTE” button is selected, the communications system makes this route the current route. The screen automatically switches back to the Operating Screen (SCR-A30).

When the “ACCEPT AND MODIFY STOPPING PATTERN” button is selected, the communications system makes this route the current route and the screen switches to the Stopping Pattern Selection Screen (SCR-D30).

When the “TURN ELECTRONIC STRIP MAP OFF” button is selected, the strip map functions of the AAS system are disabled. The button text changes to “TURN ELECTRONIC STRIP MAP ON”. This button acts as a toggle switch. This screen remains displayed after the selection of any of this button.

On figure, the second line in the «AVAILABLE ROUTES» field indicates the number of characters that the associated field could display. This number was defined accordingly to the number of characters (20) that a Side Destination Sign can display on one line.

The numbers appearing in the box under the first line in the “AVAILABLE ROUTES” screen are indicative only. They are not absolute numbers because the space used by an Arial character depends on the character displayed.

For instance: The field indicating 20 characters can include 12 “m” letters only but we performed several tests to set the field length and a common 20-character text will be displayed into the allocated space.

So the number of characters shall never exceed the number specified in the box fields and, in addition, the text length shall never exceed the allocated space to assure the proper displaying of the text.

The two first “routes” : “Cancel Route” and “Train not in Service” will always be on the two first lines of the route selection screen. Those special “routes” do not have any route number. Consequently, six asterisks are displayed instead. Their associated origin and destination fields are left blank.

The route number has been changed to a 6-alphanumeric character that mimic the NYCT's Pattern Code as shown in Letter R142 Contract: Automatic Announcement System – Revised Patterns (No. TAB-4618) . An example is shown below :

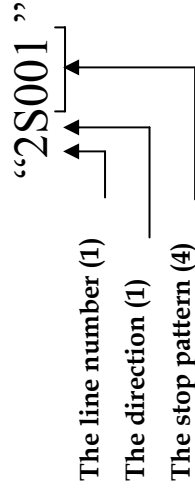

Presently only 3 digits are needed to represent the stopping pattern. One digit has been added to the 3 presently needed in case NYCT would like to use a stopping pattern of 4 digits.

ROUTE SELECTION SCREEN DESCRIPTION TABLE

| Row | ROUTE SELECTION ITEMS                   | SCREEN (SCR-C30) TYPE | UPDATED WHEN:   | STATUS WHEN NO ROUTE IS SELECTED                         | SPECIFIC DETAILS  | TEXT ATTRIBUTES & COMMENTS   |
|-----|---|-----------------------|---|--|---|--|
| 1   | AVAILABLE ROUTES BOX                    | DISPLAY BOX           | n/a   | Always present   | None  | Character's attributes:<br><ul style="list-style-type: none"> <li>• Arial 18 pts (for title)</li> <li>• White character on black background</li> <li>• Center alignment</li> </ul>   |
| 2   | Title Line in Field of available routes | Title text            | n/a   | Always present   | The Title line is generated by the TOD..<br><br><p style="background-color: yellow;">Note: The title text is subject to NYCT approval</p> | Title Line:<br>Character attributes:<br>Arial 12 pts, underline<br>Black on white background<br><br>Number of columns: 4<br>1 <sup>st</sup> column title: <u>Line</u><br>2 <sup>nd</sup> column title: #<br>3 <sup>rd</sup> column title: Route<br>4 <sup>th</sup> column title: DESTINATION |
| 3   | Available Route List                    | Field                 | Upon route pre-selection acceptance.                        | * This screen is not available when no route is selected |   | Available routes list attributes:<br>Character attributes:<br>Arial 10 pts, underline<br>Black on white background<br>Left alignment (at beginning of column)<br><br>Arial , 10 pts  |
| 4   | UP & DOWN arrows                        | Button                | n/a   | Always present   |   | Arial , 10 pts   |
| 5   | ACCEPT SELECTED ROUTE                   | Button                | n/a   | Always present and active                                |   | Arial , 10 pts   |
| 6   | ACCEPT AND MODIFY STOPPING PATTERN      | Button                | n/a   | Always present and active                                |   | Arial , 10 pts   |
| 7   | TURN ELECTRONIC STRIP MAP ON (or OFF)   | Field                 | When TOD receives the status change from the communication. | TURN ELECTRONIC STRIP MAP OFF                            | Refer to the same button in the Route pre-selection screen.   | Arial , 10 pts   |
| 8   | NAVIGATION SECTION                      | Button                | n/a   | Always active  | None  |  |
| 10  | OPERATING SCREEN                        | Button                | n/a   | Always active  | The highlighted row will not be accepted. This is considered as No route selected.  | Arial , 10 pts   |
| 11  | TROUBLE SCREEN                          | Button                | n/a   | Never active   | None  | Grayed   |



| Row | ROUTE SELECTION ITEMS | SCREEN (SCR-C30) TYPE | UPDATED WHEN: | STATUS WHEN NO ROUTE IS SELECTED | SPECIFIC DETAILS | TEXT ATTRIBUTES & COMMENTS |
|-----|-----------------------|-----------------------|---------------|----------------------------------|------------------|----------------------------|
| 12  | MAINTENANCE SCREEN    | Button                | n/a           | Never active                     | None             | Grayed                     |
| 13  | PREVIOUS SCREEN       | Button                | n/a           | Never active                     | None             | Grayed                     |

5.1.4.3 Stopping Pattern Selection Screen (SCR-D30)

DATE : **03-21-1998**

TIME : **16:45:23**

**STOPPING PATTERN SELECTION**  
ROUTE AND DESTINATION SETUP

7002<sup>2</sup>

2 7004<sup>1</sup>

1 7010<sup>2</sup>

1 7019<sup>2</sup>

2 7740

7121<sup>2</sup>

2 7525<sup>1</sup>

2 7003<sup>1</sup>

1 7035<sup>2</sup>

1 7099<sup>2</sup>

2 7222

## STATIONS

| STATION NAME              | STATUS        |
|---------------------------|---------------|
| Dyre Ave                  | Active        |
| Baychester Ave            | <b>Skip</b>   |
| Gun Hill Rd               | Active        |
| Pelham Pkwy               | Active        |
| <b>Pelham Pkwy</b>        | <b>Active</b> |
| E 180 St                  | Active        |
| E Tremont Ave/ W Farms Sq | Active        |
| 174 St                    | Active        |
| Freeman St                | <b>Skip</b>   |
| Simpson St                | Active        |
| Interval Ave              | Active        |

ACCEPT  
STATION  
SELECTION

TOGGLE  
ACTIVE/SKIP  
STATUS

NEW ROUTE  
SELECTION

TURN  
AUTOMATIC  
MESSAGES  
OFF

UP

DOWN

CURRENT  
STATION  
(synchronize)

OPERATING  
SCREEN

TROUBLE  
SCREEN

MAINTENANCE  
SCREEN

PREVIOUS  
SCREEN

SCR-D30

Within the “STATIONS” text box, there is 1 header row (Station name and Status) exactly 10 lines of stations visible at one time. The selected station is the one highlighted by the yellow bar in the white text box area. The “UP” and “DOWN” arrows at the bottom of the text box are used to scroll through the list of available messages. When scrolling, the text moves under the selection bar; the selection bar remains fixed within the text box. When the text is scrolled to the end of the list, the “DOWN” arrow is grayed out (inactive). Similarly, when the text is scrolled to the top of the list, the “UP” arrow is grayed out (inactive).

When the “TOGGLE ACTIVE/SKIP STATUS” button is selected, the status of the currently selected station toggles between Active and Skip.

When the “CURRENT STATION (synchronize)” button is selected, the communications establish the AAS current station pointer to the selected station.

When the “ACCEPT STATION SELECTION” button is selected, the communications system make this station list the active list for the current route. The screen automatically switches back to the Operating Screen (SCR-A30).

When the “NEW ROUTE SELECTION” button is selected, screen switches to the Route Pre-Selection Screen (SCR-B30).

When the “TURN AUTOMATIC MESSAGE OFF” button is selected, the audio functions of the AAS system are disabled. The button text changes to “TURN AUTOMATIC MESSAGE ON”. This button acts as a toggle switch.

**STOPPING PATTERN SELECTION SCREEN DESCRIPTION TABLE**

| ROW | STOPPING PATTERN SELECTION ITEMS          | SCREEN (SCR-D30) | TYPE  | UPDATED WHEN:  | STATUS WHEN NO ROUTE IS SELECTED   | SPECIFIC DETAILS   | TEXT ATTRIBUTES & COMMENTS |
|-----|---|------------------|---|--|--|--|----------------------------|
| 2   | AVAILABLE STATIONS BOX                    | DISPLAY BOX      | n/a   | * This screen is not accessible if no route is selected. | None   | Character's attributes:<br>• Arial 18 pts<br>• White character on black background<br>• Center alignment   |                            |
| 3   | Title Line in Field of available stations | Title text       | n/a   | * This screen is not accessible if no route is selected. | Refer to the highlight bar description for more details.   | Title Line:<br>Character attributes:<br>Arial 12 pts, underline<br>Black on white background<br><br>Number of columns: 2<br>1 <sup>st</sup> column title: <u>STATION NAME</u><br>2 <sup>nd</sup> column title: <u>STATUS</u> |                            |
| 4   | Available Stations List                   | Field            | Upon route selection (and modify) acceptance. | * This screen is not available when no route is selected | The TOD shall convert the status information from "Active" to "Skip" and vice versa at each communication with the Communication system (both way) and before displaying the information..                   | Station Name Length: 20 characters<br>Available stations list attributes:<br>Character attributes:<br>Arial 12 pts, underline<br>Black on white background<br>Left alignment (at beginning of column)                        |                            |
| 5   | UP & DOWN arrows                          | Button           | n/a   | * This screen is not accessible if no route is selected. | Refer to the arrow description and behavior for more details.  | Arial , 10 pts   |                            |
| 6   | TOGGLE ACTIVE/SKIP STATUS                 | Button           | n/a   | * This screen is not accessible if no route is selected. | None   | Arial , 10 pts   |                            |
| 7   | CURRENT STATION (synchronize)             | Button           | n/a   | * This screen is not accessible if no route is selected. | When the TOD will switch to the Operating Screen after that the button "ACCEPT STATION SELECTION" has been depressed, the "Next Stop" information will be updated consequently the current station selection | Arial , 10 pts   |                            |
| 8   | ACCEPT STATION SELECTION                  | Button           | n/a   | * This screen is not accessible if no route is selected. |  | Arial , 10 pts   |                            |
| 9   | NEW ROUTE SELECTION                       | Button           | n/a   | * This screen is not accessible if no route is selected. |  | Arial , 10 pts   |                            |

| ROW | STOPPING PATTERN SELECTION ITEMS    | SCREEN (SCR-D30) | TYPE   | UPDATED WHEN:  | STATUS WHEN NO ROUTE IS SELECTED   | SPECIFIC DETAILS | TEXT ATTRIBUTES & COMMENTS |
|-----|-------------------------------------|------------------|--|--|--|------------------|----------------------------|
| 10  | TURN AUTOMATIC MESSAGES OFF (or ON) | Field            | When TOD receives the status from the communication system | * This screen is not accessible if no route is selected. | The Automatic Messages will be ON by default when the route is selected. Therefore, the label will indicate Turn Automatic Messages OFF.   | Arial, 10 pts    |                            |
| 11  |                                     | Button           | n/a  | Always active  | None   |                  |                            |
| 12  | NAVIGATION SECTION                  |                  |  |  |  |                  |                            |
| 13  | OPERATING SCREEN                    | Button           | n/a  | Always active  | The current modification as well as all the changes will be withdrawn (reset to the default value/original settings) if the Accept Selection entry has not been done previously. | Arial, 10 pts    |                            |
| 14  | TROUBLE SCREEN                      | Button           | n/a  | Never active   | None   | grayed           |                            |
| 15  | MAINTENANCE SCREEN                  | Button           | n/a  | Never active   | None   | grayed           |                            |
| 16  | PREVIOUS SCREEN                     | Button           | n/a  | Never active   | None   | grayed           |                            |

5.1.4.4 Special announces and interior messages (SCR-B20)

DATE : **03-21-1998**

TIME : **16:45:23**

**SPECIAL MESSAGE SELECTION**  
SPECIAL MESSAGES

7002<sup>2</sup>

2 7004<sup>1</sup>

1 7010<sup>2</sup>

1 7019<sup>2</sup>

2 7740

7121<sup>2</sup>

2 7525<sup>1</sup>

2 7003<sup>1</sup>

1 7035<sup>2</sup>

1 7099<sup>2</sup>

2 7222

**AVAILABLE MESSAGES**

| #   | DESCRIPTION                                     |
|-----|---|
| 001 | Terminus.                                       |
| 002 | Please be patient, we will be underway shortly. |
| 003 | We apologize for unavoidable delay.             |
| 004 | ...   |
| 005 | ...   |
| ... | ...   |

UP

DOWN

PLAY  
SELECTED  
SPECIAL  
MESSAGE

TURN TEST  
MESSAGES  
ON

TURN  
AUTOMATIC  
MESSAGES  
OFF

PREVIOUS  
SCREEN

OPERATING  
SCREEN

TROUBLE  
SCREEN

MAINTENANCE  
SCREEN

PREVIOUS  
SCREEN

SCR-B20

Within the “AVAILABLE MESSAGES” text box, there is 1 header row (Message # and Description) and exactly 10 lines of special messages visible at one time. The selected message is the one highlighted by the yellow bar in the white text box area. The “UP” and “DOWN” arrows at the bottom of the text box are used to scroll through the list of available messages. When scrolling, the text moves under the selection bar; the selection bar remains fixed within the text box. When the text is scrolled to the end of the list, the “DOWN” arrow is grayed out (inactive). Similarly, when the text is scrolled to the top of the list, the “UP” arrow is grayed out (inactive).

When the “PLAY SELECTED SPECIAL MESSAGE” button is selected, the communications systems plays the currently selected special message.

When the “TEST AUTOMATIC MESSAGES” button is selected, the communication system initiates the appropriate test, as per Technical Specification 13.2.1.1.1.

When the “TURN AUTOMATIC MESSAGE OFF” button is selected, the audio functions of the AAS system are disabled. The button text changes to “TURN AUTOMATIC MESSAGE ON”. This button acts as a toggle switch.

The screen remains displayed after the selection of any of these three buttons.

SPECIAL MESSAGE SELECTION SCREEN DESCRIPTION TABLE

| ROW | SPECIAL MESSAGES SELECTION ITEMS          | SCREEN (SCR-B20) | UPDATED WHEN:  | STATUS WHEN NO ROUTE IS SELECTED                   | SPECIFIC DETAILS   | TEXT ATTRIBUTES & COMMENTS   |
|-----|---|------------------|--|--|--|--|
| 1   | AVAILABLE MESSAGES BOX                    | DISPLAY BOX      | n/a  | Not relevant                                       | None   | Character's attributes:<br><ul style="list-style-type: none"> <li>• Arial 18 pts</li> <li>• White character on black background</li> <li>• Center alignment</li> </ul>                                   |
| 2   | Title Line in Field of available messages | Title text       | n/a  | Not relevant                                       | Refer to the highlight bar description for more details.   | Title Line:<br>Character attributes:<br>Arial 12 pts, underline<br>Black on white background<br><br>Number of columns: 2<br>1 <sup>st</sup> column title: #<br>2 <sup>nd</sup> column title: DESCRIPTION |
| 3   | Available Messages List                   | Field            | When the operator depress the Special Messages button on the Operating Screen. | Not relevant                                       |  | Available messages list attributes:<br>Character attributes:<br>Arial 12 pts, underline<br>Black on white background<br>Left alignment (at beginning of column)  |
| 4   | UP & DOWN arrows                          | Button           | n/a  | Not relevant                                       | Refer to the arrow description and behavior for more details.  | Arial , 10 pts   |
| 5   | PLAY SELECTED SPECIAL MESSAGE             | Button           | n/a  | This button is inactive when no route is selected. | By default, the first row is highlighted.  | Arial , 10 pts   |
| 6   | TURN TEST MESSAGES ON (or OFF)            | Field            | When TOD receives the status from the communication system                     |  | By default, the Test Messages will be OFF. Therefore, the label will indicate Turn Automatic Messages ON.  | Arial , 10 pts   |
| 7   | TURN AUTOMATIC MESSAGES OFF (or ON)       | Field            | When TOD receives the status from the communication system                     | Not relevant                                       | The Automatic Messages will be ON by default when the route is loaded. Therefore, the label will indicate Turn Automatic Messages OFF.           | Arial , 10 pts   |
| 8   |   | Button           | n/a  | Not relevant                                       | None   |  |
| 9   | NAVIGATION SECTION                        |                  |  |  |  |  |
| 10  | OPERATING SCREEN                          | Button           | n/a  | Not relevant                                       | The highlighted row will not be selected and the default row selection will be selected upon re-entry into the Special Message Selection screen. | Arial , 10 pts   |



| ROW | SPECIAL MESSAGES SELECTION ITEMS | SCREEN (SCR-B20) | UPDATED WHEN: | STATUS WHEN NO ROUTE IS SELECTED | SPECIFIC DETAILS | TEXT ATTRIBUTES & COMMENTS |
|-----|----------------------------------|------------------|---------------|----------------------------------|------------------|----------------------------|
|     |                                  | TYPE             |               |                                  |                  |                            |
| 11  | TROUBLE SCREEN                   | Button           |               | Never active                     | No impact        | grayed                     |
| 12  | MAINTENANCE SCREEN               | Button           |               | Never active                     | No impact        | grayed                     |
| 13  | PREVIOUS SCREEN                  | Button           |               | Never active                     | No impact        | grayed                     |

5.1.5 DISPLAY TIME SETUP SCREEN (SCR-B10)

DATE : 03-21-1998

DISPLAY TIME SETUP  
OPERATING SCREEN

TIME : 16:45:23

7002 2 7004 1 7010 2 7019 2 7740

7121 2 7525 1 7003 1 7035 2 7099 2 7222

**HOURS**

|    |   |      |
|----|---|------|
| UP | 4 | DOWN |
| UP | 5 | DOWN |
| UP | 6 | DOWN |
| UP | 1 | DOWN |
| UP | 2 | DOWN |
| UP | 3 | DOWN |

**MINUTES**

|    |   |      |
|----|---|------|
| UP | + | DOWN |
|----|---|------|

**SECONDS**

|    |   |      |
|----|---|------|
| UP | 2 | DOWN |
| UP | 3 | DOWN |

7222

ACCEPT TIME

OPERATING  
SCREEN

TROUBLE  
SCREEN

MAINTENANCE  
SCREEN

PREVIOUS  
SCREEN

SCR-B10

5.1.6 TROUBLE SCREEN (DEFAULT) (SCR-A20)

DATE : 03-21-1998

TIME : 16:45:23

## TROUBLE SCREEN

7002 2

2 7004 1

1 7010 2

1 7019 2

2 7740

7121 2

2 7525 1

2 7003 1

1 7035 2

1 7099 2

2 7222

### ACTIVE TROUBLE

DOOR NOT CLOSED  
DOOR NOT CLOSED  
STUCK BRAKE  
HOT CAR

### ADDITIONAL INFORMATION

1. CALL ROAD CAR INSPECTOR  
- CUTOUT DEFECTIVE TRUCK

UP

DOWN

OPERATING SCREEN

TROUBLE SCREEN

MAINTENANCE SCREEN

PREVIOUS SCREEN

SCR-A20

Within the “ACTIVE TROUBLE” text box, there is approximately 15 lines of active troubles visible at one time. The current trouble is the one highlighted by the colored bar in the text box area (red in this example). This bar is the reverse video if the text. This means that for the HOT CAR trouble, the bar would have an AMBER background with black text. The “UP” and “DOWN” arrows at the right of the text box are used to scroll through the list of current trouble. When scrolling, the text moves under the selection bar; the selection bar remains fix within the text box. When the text is scrolled to the end of the list, the “DOWN” arrow is grayed out (inactive). Similarly, when the text is scrolled to the top of the list, the “UP” arrow is grayed out (inactive).

When the same trouble is present on multiple cars (has for the STUCK BRAKE example), only one line of text is displayed with all implicated cars highlighted in the consist graphical representation area (top). This is true for all troubles but the DOORS relates troubles (refer to Trouble Screen with door trouble (SCR-A20) image for more details).

For new troubles, the text in the ACTIVE TROUBLE list flashes when the Trouble screen is displayed. If the new trouble text is highlighted by the colored bar, then the text will still flash and the text color will toggle between black and the color of the bar. Once the operator switches to another screen form the Trouble screen, the flashing troubles are considered “acknowledged” and will no longer flashes when the screen is recalled at a later time.

The graphical consist representation always uses the color RED and does not flash to indicated the implicated car for the current trouble. When the operator scrolls through the list of trouble using the arrows at the right, the consist graphical representation is refreshed to show the implicated cars for the newly selected current trouble. The same is true for the ADDITIONAL INFORMATION displayed to the right of the screen : it is also refreshed to display the text matching the currently selected trouble.

5.1.7 TROUBLE SCREEN WITH DOOR TROUBLE (SCR-A20)

DATE : 03-21-1998

TROUBLE SCREEN

TIME : 16:45:23

|      |   |      |   |      |   |      |   |      |   |      |   |      |   |      |   |      |   |      |   |      |   |
|------|---|------|---|------|---|------|---|------|---|------|---|------|---|------|---|------|---|------|---|------|---|
| 7002 | 2 | 7004 | 1 | 7010 | 2 | 7019 | 2 | 7740 | 2 | 7121 | 2 | 7525 | 1 | 7003 | 2 | 7035 | 2 | 7099 | 2 | 7222 | 2 |
|------|---|------|---|------|---|------|---|------|---|------|---|------|---|------|---|------|---|------|---|------|---|

### ACTIVE TROUBLE

DOOR NOT CLOSED

DOOR NOT CLOSED

STUCK BRAKE

HOT CAR

### CAR #7019

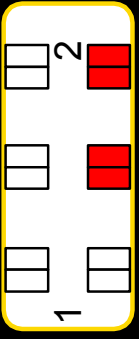

### ADDITIONAL INFORMATION

UP

DOWN

OPERATING SCREEN

TROUBLE SCREEN

MAINTENANCE SCREEN

PREVIOUS SCREEN

SCR-A20

Within the “ACTIVE TROUBLE” text box, there is approximately 15 lines of active troubles visible at one time. The current trouble is the one highlighted by the colored bar in the text box area (red in this example). This bar is the reverse video if the text. This means that for the HOT CAR trouble, the bar would have an AMBER background with black text. The “UP” and “DOWN” arrows at the right of the text box are used to scroll through the list of current trouble. When scrolling, the text moves under the selection bar; the selection bar remains fix within the text box. When the text is scrolled to the end of the list, the “DOWN” arrow is grayed out (inactive). Similarly, when the text is scrolled to the top of the list, the “UP” arrow is grayed out (inactive).

When the same DOOR related trouble is present on multiple doors in the same car (current DOOR NOT CLOSE trouble in example), only one line of text is displayed with all implicated doors opening highlighted in the car graphical representation present in the ADDITIONAL INFORMATION area (right). This car representation is only displayed for DOORS related troubles. Different line of text are used for the same DOOR related troubles in different cars. For other types of troubles, refer to the description given with the Trouble screen (Default) (SCR-A20) image.

For new troubles, the text in the ACTIVE TROUBLE list flashes when the Trouble screen is displayed. Once the operator switches to another screen form the Trouble screen, the flashing troubles are considered “acknowledged” and will no longer flashes when the screen is recalled at a later time.

The graphical consist representation always uses the color RED and does not flash to indicated the implicated car for the current trouble. When the operator scrolls through the list of trouble using the arrows at the right, the consist graphical representation is refreshed to show the implicated cars for the newly selected current trouble. The same is true for the ADDITIONAL INFORMATION displayed to the right of the screen : it is also refreshed to display the text matching the currently selected trouble.

5.1.8 AAS SETTING ERROR HANDLING SCREEN

The screenshot displays the AAS Setting Error Handling Screen. At the top, it shows the date as 03-21-1998 and the time as 16:45:23. Below this is a 'ROUTE SELECTION ROUTE AND DESTINATION SETUP' section with a grid of route numbers: 7002, 7004, 7010, 7019, 7740, 7121, 7525, 7003, 7035, 7099, and 7222. A large yellow error message reads 'AAS SETTING IS PRESENTLY IN PROCESS IN OTHER CAB'. A callout points to the message with the text 'Arial18 pt bold'. At the bottom, there is an 'OK' button with a callout 'Arial12 pt'. Navigation buttons for 'OPERATING SCREEN', 'TROUBLE SCREEN', 'MAINTENANCE SCREEN', and 'PREVIOUS SCREEN' are located at the bottom of the screen. The screen identifier 'SCR-C30' is in the bottom right corner.

If an error is reported by the communication system or detected by the TOD\* while the TOD is displaying one of the specific AAS setting screens (excluding *Operating Screen*), then the TOD will display an *Error Handling Message Window* to advise the operator of the reported problem. This Error Handling Message Pop-Up Window is superimposed over the main section area while all current screen's buttons are not enabled, except the OK button on this Error Pop-Up Window. The Error Handling Message Pop-Up Window can be superimposed over the route pre-selection screen, the route selection screen, the stopping pattern selection screen and the special message selection screen.

The Error Handling Message Window prompts the operator to acknowledge the reported error. Upon acknowledgment by the operator, the TOD immediately returns to the *Operating Screen*. When this Pop Up window is displayed, all the other buttons on the screen are not selectable.

5.1.9 AAS SETTING WARNING SCREEN

The screenshot displays the 'ROUTE SELECTION ROUTE AND DESTINATION SETUP' screen. At the top left, the date is '03-21-1998' and the time is '16:45:23'. Below the title, there are two columns of route numbers: '1 7010 2' and '2 7004 1' in the first column; '1 7019 2', '2 7740', '7121 2', '2 7525 1', '2 7003 1', '1 7035 2', '1 7099 2', and '2 7222' in the second column. A yellow callout bubble points to the text 'PLEASE WAIT' with the note 'Arial 18 pt bold'. Below the route numbers, a large yellow warning message reads: 'PLEASE WAIT ROUTE SETTING IN PROGRESS PRESSING OPERATING SCREEN BUTTON WILL CANCEL ROUTE SELECTION'. At the bottom, there are four buttons: 'OPERATING SCREEN' (highlighted with a green border), 'TROUBLE SCREEN', 'MAINTENANCE SCREEN', and 'PREVIOUS SCREEN'. The screen ID 'SCR-F30' is located at the bottom right.

While the TOD is displaying “ROUTE SELECTION” AAS setting screens and the button “ACCEPT SELECTED ROUTE” or the button ”ACCEPT AND MODIFY STOPPING PATTERN”, then the TOD will display an *Warning Message Window* to advise the operator that the completion of the requested command is in process. This Warning Message Pop-Up Window is superimposed over the main section area while all current screen’s buttons are not enabled, except the Operating Screen button. If the operating button is depressed before that the TOD switches by itself to the “OPERATING SCREEN” then, the previous route set-up will be lost. The Warning Message Pop-Up Window can be superimposed over the route selection screen only.