

# Minutes of the IEEE SURGE PROTECTIVE DEVICES COMMITTEE

May 17, 2001  
Tradewinds – St. Pete Beach, Florida

The meeting was called to order at 3:50 PM by chairperson Dennis Lenk.

## 1.0 Introductions: All in attendance were self-introduced. In attendance were:

Gerald Lee	BPA	M	Don Worden	Retired	M
Hans Steinhoff	Current Techno.	M	Bill Goldbach	Innovated Technology	M
Ray Hill	GA Tech/NEETRAC	M	Mike Comber	HPS/Ohio Brass	M
Rao Thallam	SRP	M	H Wolfgang Oertel	Bourns CPP	M
Thomas Rozek	Detroit Edison	M	Frank Waterer	Schneider Electric	M
Mick Maytum	Power Innovations	M	Carl Lindquist	San-O Industrial	M
Andrew R Hileman	Consultant	M	Anoi Haa	Consultant	M
F Martzloff	NIST	M	Jim Wilson	Ameren Services	M
R Cohen	Panamax	M	Steven P Hensley	Joslyn Mfg Co	M
Michael Champagne	Entergy	G	Bengt Johnnerfelt	ABB	M
David W Jackson	RW Beck	M	Richard Chadwick	Dehn Inc	IP
Bill Curry	Tyco Electronics	M	Jayanti Sangani	FAA	G
Tom Conrad	Lea International	IP	Mark Drabkin	LEC Inc	IP
Volker Hinrichsen	Siemens	M	Joe Gerace	FAA	IP
Fred Basso	Dehn Inc	IP	Andy Ickowicz	IEEE Standards	IP/V
Savoula Amanatidis	IEEE Standards	V	D Lenk	Ohio Brass	M
J Woodworth	Cooper Power Systems	M			

## 2.0 Acceptance of Minutes of the Fall Meeting in Cincinnati, Ohio

The minutes were accepted as written.

## 3.0 Subcommittee Reports

### 3.1 Administrative & Standards - D. Lenk

#### 3.1 Administrative and Standards Subcommittee Report to SPDC Committee

1. Tom Hartman, SPDC website coordinator, reports that the SPDC website is running very well. Tom encourages working group and subcommittee chairs to submit minutes and related documents of interest for posting on the SPDC Website. He strongly encouraged low voltage members to take advantage of this service.
2. Regarding membership, John Posey requested and was granted a change in membership status from SPDC member to Honorary member.
3. The SPDC Operations Manual has been updated and approved by the PES Operations and Procedures Subcommittee. Good job by Jon Woodworth. The new Operations Manual has been placed on the SPDC Website.
4. At the request of the Power Engineering Society Technical Committee, the SPDC submitted an article to the PE Review describing the activities of the SPDC. This article appeared in the

- November issue of the PES Review and hopefully will be of sufficient interest to encourage new attendees at future SPDC meetings.
5. Joe Koepfinger has asked that the SPDC request a Liaison D coordination to WG 3 of IEC TC 37. Dennis Lenk, with the assistance of Joe, will write a letter to Judy Gorman at IEEE requesting this liaison.
  6. A Ballot Resolution Committee (BRC) was organized to resolve negative responses on a recent SPDC ballot. It was suggested that this procedure should be defined more formally, perhaps in the Operations Manual. It was noted that the Computer Society already uses this procedure to resolve negative ballots. Bill Goldbach agreed to contact the Computer Society to determine if they have already implemented this into their Operations Manual.
  7. There was considerable discussing at A&S regarding problems with electronic balloting. Bill Goldbach and Jim Wilson will work with Steve Kahofer at IEEE to resolve electronic balloting issues.
  8. Joe Koepfinger expressed concern that the SPDC develop a long term plan regarding standards writing and also as a technical resource organization. No specific action item was developed.
  9. As the IEEE has eliminated mandatory coordination between technical committees, the position of coordinator has been eliminated. We will now only have liaison with other technical committees. The A&S Subcommittee reviewed the current Liaison and Coordinator listing and updated the liaison listing to reflect current liaison activity.
  10. Francois Martzloff's request to add the NIST Practice Guide entitled "Surges Happen!" to the SPDC website was discussed. It was decided that the chairman should contact the IEEE to determine if there were any liability issues associated with placing this document in the SPDC website.
  11. Don Worden announced that this would be his last meeting as chair of the LV Subcommittee. Don is actively seeking a replacement to assume this very important position. Don plans to have this position filled by the Fall meeting in Niagara Falls.
  12. The A&S chair approved Mike Comber to assume the chair of WG 3.3.11, Continuous Revisions of C62.11 Standard, replacing Tom Hartman. A new PAR for WG 3.3.11 is in the process of being issued.
  13. It was noted that Francois Martzloff will be a member of the recently formed US National Delegation to IEC TC 81 on Lightning Protection. The A&S unanimously agreed to support Francois' offer to serve as Liaison from that group to the SPDC. The secretary will add Francois to the SPDC Liaison listing.
  14. A&S members were asked individually to generate a "short list" of SPDC members who should be considered as IEEE Fellow candidates. This listing will be reviewed at the Fall meeting of A&S.
  15. There was continuing discussing regarding the excessive amount of time it takes to get WG, Subcommittee, and SPDC meeting minutes published. In particular, the time between the Spring and Fall meeting is typically less than 5 months. To allow members an opportunity to prepare for the Fall meeting, the A&S reviewed guidelines for time frames for submitting meeting minutes:

First, regarding **submittals of WG and SubC Meeting minutes** to SPDC Secretary and SPDC webmaster, **WG chairs are asked to have WG minutes submitted to their Subc chairs within 2 weeks of the SPDC meeting. Subc chairs are requested to have Subc meeting minutes submitted to the SPDC secretary within 4 weeks of the SPDC meeting.** WG and Subc chairs are **encouraged to also sent parallel copies to Tom Hartman (Website manager)** so that minutes can also be posted on the website. Also, **all website postings for upcoming meetings should be e-mailed to Tom Hartman at least a month prior to the meeting** to insure information gets posted prior to the targeted SPDC meeting. This last request will best assure that the posting makes the website prior to the upcoming meeting.

### 3.1.1 Standards Coordinator –J. Wilson/W. Goldbach

PES-SPDC High Voltage Standard Coordinator Report  
For Spring 2001 PES - SPDC Meeting  
Jim Wilson - May 5, 2001

The current status of the various documents in the high voltage area of the SPDC is shown in the Excel file hvstatus.xls, dated May 3, 2001.

**The following have been accomplished since our Fall 2000 meeting:**

Requested and obtained Standards Board approval of a PAR extension until December 2002 for work on the new standard PC62.21, The Application of Surge Voltage Protective Equipment on AC Rotating Machinery 1000 Volts and Greater.

Requested and obtained Standards Board approval of a PAR extension until December 2002 for work on the revision of IEEE Standard 32-1972, the Standard Requirements, Terminology, and Test Requirements for Neutral Grounding Devices. This is being done as PC62.91.

Formed a balloting group and conducted a ballot on the reaffirmation of C62.92.4-1991, the IEEE Guide for the Application of Neutral Grounding in Electrical Utility Systems, Part IV - Distribution. The initial ballot results were 24 approve, 6 approve with comments, 3 negative with comments, 0 abstain, 6 no return. However, an incorrect version of the standard was provided with the ballot, so when the correct version is available, the ballot will have to be done again with the correct document.

**The following should be done in the near future:**

Submit and obtain a PAR for the revision of C62.11-1999, the IEEE Standard for Metal-Oxide Surge Arresters for AC Power Circuits (>1kV). This is past due as the working group has already had their one allowed meeting without the benefit of a PAR.

Re-ballot the reaffirmation of C62.92.4-1991 mentioned above when the correct version is available.

Either form a balloting group for PC62.23, the revision of the Application Guide for Surge Protection of Electric Generating Plants, if it is ready for ballot, submit a request for a PAR extension for the work if one will be needed, or form a balloting group for the reaffirmation of the existing C2.23-1995 document, if we are no longer planning to revise the document.

Form a balloting group and reaffirm IEEE Standard 1313.1-1996, the IEEE Standard for Insulation Coordination - Definitions, Principles, and Rules unless we are want to revise the document.

I would also suggest that we submit and obtain a PAR for the revision of IEEE Standard 1313.2-1999, the IEEE Guide for the Application of Insulation Coordination if we are planning to revise this document before it is scheduled to expire in 2004.

**Our current schedules have the following dates for starting ballots on new or revised HV documents:**

PC62.91 June 1, 2001  
PC62.22 December 1, 2001  
PC62.21 July 1, 2002

**Additional comments concerning the Standards Board and the PES Technical Council Standards Coordinating Committee.**

The developers of standards are no longer required to identify coordination on the IEEE PAR form and will therefore not be required to supply proof of coordination when they submit the draft standard for approval, [other than with SCC 10 (IEEE Dictionary), SCC 14 (Metrics), and the IEEE Standards Editor]. All non-mandatory coordination will be handled at the Sponsor's discretion. We should take a look at if or how we want the SPDC members listed as our coordinators for the various documents of other Sponsors to function. Communication with external bodies is still encouraged through participation in standards working group activities and inclusion of appropriate persons in the document balloting pools.

I plan to notify all of the people on the PES Standard Coordination Committee member list whenever I receive a notification that the high voltage area of the SPDC has received an approved PAR.

RevCom no longer requires the submission of paper copies of drafts. The Working Guide for Submittal of Proposed Standards contains information on necessary requirements for submitting documents. This information can be found on the IEEE-SA web page using <http://standards.ieee.org/guides/revguide.html>.

Individuals who sign a PAR form must be IEEE-SA members.

NesCom is redesigning the PAR form. The Instructions for and the PAR forms can be found on the IEEE-SA web page using <http://standards.ieee.org/guides/par/index.html>.

If a project is not completed within the time allotted by the PAR, an extension request form will be sent to the Sponsor and the Sponsor must complete the form and submit it to NesCom for review.

John Posey submitted some suggested changes to the PES Standard Coordination Committee for updating their procedures.

For Editorial review of a draft document, contact Yvette Ho Sang at 732-562-3814 or at y.hosang@ieee.org.

The IEEE-SA Director, Technical Programs, Theresa deCourcelle, was gathering information to generate a list of any IEEE standards or drafts that have been adopted by ISO or IEC and a list of any IEEE standards which are being used outside of the United States.

## 3.2 Bibliography – C. Lindquist

### Subcommittee 3.2 Bibliography and Definitions

Meeting on 05/16/01 in St. Pete Beach, FL

The Bibliography and Definitions Subcommittee met on 05/16/01 at the Trade Winds Resort, St. Pete Beach, FL for approximately 4 hours. Those in attendance were asked to introduce themselves. They included:

#### Members

Carl Lindquist – Chairman  
Francois Martzloff  
Hans Steinhoff  
Jim Wilson  
Don Worden  
Dennis Lenk  
Jon Woodworth  
David Jackson

#### Guests

Michael Maytum  
Frank Waterer  
Gary Goedde

#### **Opening:**

The meeting was opened at 08:00 AM with a brief overview of topics to be discussed. An agenda was passed out to all attendees.

#### **Review and Disposition of Prior Meeting Minutes:**

The minutes of the Fall, 2000 meeting in Cincinnati, OH were read through by the attendees and all were asked to provide comments on errors or omissions. With no responses a motion was made and seconded to accept the minutes. The motion passed.

#### **Bibliography:**

The bibliography was the next item on the agenda. The members were advised that the initial bibliography list received at the last meeting had been posted on the IEEE-SPDC Web Site. A second bibliography list was provided to be posted, as well as reference to the new booklet "Surges Happen!" It was proposed that the Bibliography sections of the Web Site be broken down into active Subcommittees (e.g. 3.3, 3.4, 3.5, 3.6) and the associated bibliographies be listed in the unrestricted area of the 3.2 page. It was further recommended that we even provide separate folders for each Working Group, using the Working Group's name rather than number. This will be the goal and it will be done in this manner as more bibliographies become available. It is strongly recommended that future bibliography lists and papers be provided to the 3.2 Subcommittee for posting in data format. This eliminates the problems associated with scanning a paper document into the computer for posting.

A better way to list the bibliography information was requested. One recommendation was to use the new Adobe PDF Text file format in Acrobat 5.0 because it is easily entered and can be searched for key words. Mr. M. Maytum had a copy of this software on his notebook and provided a brief demonstration. This process will be reviewed for use in the future.

**Definitions:**

A question was raised regarding whether or not the display of the "PES" and "IEEE" logos on the cover page of the Dictionary was appropriate. I was requested to contact Rau Thallam to find out the reasoning used when these logos were selected for use. I spoke with Rau a day later and his explanation was that this dictionary was for us only in the C62 organization and was not being sold. This had never been challenged.

There was a recommendation from the Chair that at least one member of any Working Group submitting definitions for acceptance to the 3.2 Subcommittee be available at the meeting. This will facilitate the members in determining whether any new or revised definition is a justified and acceptable change to the IEEE-SPDC Dictionary.

A procedure to be followed for future definition submissions to 3.2 was agreed upon at this meeting. This procedure will require that the new and/or revised definitions be provided to the Working Group's Subcommittee and the 3.2 Subcommittee concurrently. This must be done as early as possible after the work by the Working Group has concluded all debate on the proposed definitions. The 3.2 Subcommittee will assess the proposed additions and changes based on agreements made at the meeting, and give interim approval provided they are accepted as presented and/or edited, and no changes are made to the definitions subsequently. This will permit a Working Group to proceed with an understanding of what the final definitions will be prior to formal balloting of the document. If any subsequent changes are made to the definitions, they must be resubmitted to through the appropriate Subcommittee to the 3.2 Subcommittee for reevaluation. Review by the appropriate Subcommittee of definitions to be submitted to the 3.2 Subcommittee is essential to assure that work on similar definitions in different Working Groups has been well coordinated.

It was further agreed that a second, interim, dictionary will be generated to contain terms that have been given interim approval, but for which the documents have not yet been formally approved. The IEEE-SPDC Dictionary will be posted on the unprotected side of the 3.2 Subcommittee Web Site. The second, interim, dictionary will also be published on the same Web Site, but in the password protected area. After a given document has been successfully balloted and published, the words and terms involved will be moved to the IEEE-SPDC Dictionary and removed from the password protected area of the Web Site.

The style of our definitions will follow the style used in IEEE Std 100 rather than the IEC style.

At the recommendation of the Chair, the latest update of the IEEE-SPDC Dictionary was submitted for approval by the 3.2 Subcommittee. A motion was made, seconded and passed unanimously.

The next order of business was to begin acceptance of new and/or revised definitions. Frank Waterer, Working Group 3.6.6, submitted four definition recommendations from a draft copy of PC 62.72. The terms reviewed, and the dispositions, are as follows:

TVSS: Transient Voltage Surge Suppressor - The definition for this particular term was modified from that presented. The resulting definition was approved conditionally, pending no further changes when it is reviewed at the 3.6 Subcommittee meeting later this week.

Surge Protective Device - After some review, it was determined that this term is already in the IEEE Std 100, 1996, Sixth Edition, and no further action would be needed by our Subcommittee.

Main Overcurrent Protective Device - This definition was slightly modified and approved conditionally, pending no further changes when it is reviewed at the 3.6 Subcommittee meeting.

Cascade Coordination - There was some concern regarding this term as related to an already defined IEC term. Francois Martzloff will work with Frank Waterer to provide the alternative as soon as possible.

Hans Steinhoff continued with an additional term for PC 62.72, after the group returned from a break.

Unprotected Circuit - It was decided that this term should be discussed further at the 3.6 Subcommittee meeting.

Mr. Steinhoff also had one term from C 62.48, Draft 3.

Power Cross - This is a new term and the proposed definition was accepted conditionally, provided no further changes are made when it is reviewed at the 3.6 Subcommittee meeting.

It is requested that all of the above referenced definitions that were accepted pending review by the 3.6 Subcommittee be forwarded to me by E-Mail, provided they are found to be acceptable. They will then be placed in the new interim dictionary.

Dave Jackson had a rough list of 14 potential definitions, but elected to review them again and resubmit at the next 3.2 Subcommittee meeting.

All were advised that we have received a new copy of the newest IEC Dictionary from J. Koepfinger. This was an action item from the last meeting. I advised that, per a conversation with Joe Koepfinger yesterday, the status of the Liaison D with WG 11 of TC-37 is still unknown. This will be brought up at our next meeting.

#### **Old Business:**

Francois Martzloff reported that work is continuing on the preservation of old IEEE documents. We will continue to check on the progress at future meetings.

The issue of getting new terms submitted to the 3.2 Subcommittee without jeopardizing completion schedules of documents in progress was addressed above in this report. We will continue to make changes where possible to expedite the process where possible. Efforts by the task force established to set time limits for getting documents to the 3.2 Subcommittee appear to have improved the old system. No further action was taken on the responsibilities of this task force.

#### **New Business:**

Three issues were brought up under new business. The first was whether or not the 3.2 Subcommittee would have responsibility to oversee term letter designations. It was decided that we would only become involved at this time if such a letter designation is part of a definition being submitted.

A second issue was raised regarding the disposition of definitions in the IEEE-SPDC Dictionary after a given standard has been reissued. The decision was made that definitions included in the IEEE-SPDC Dictionary would be deleted when a standard had been superceded. Old definitions should remain in the IEEE-Std 100. This document is now being overseen by Dave Jackson.

There appear to be many definitions in existing C62 standards for which the terms and definitions are not included in either the IEEE-Std 100 or IEEE-SPDC Dictionary. This will be reviewed further prior to the next meeting to determine if, and how, we would repair this apparent oversight.

The meeting was adjourned at approximately 11:40 AM.

#### **Summary of Action Items: (Responsible Member)**

- 1) Post new bibliography material on IEEE-SPDC Web Site (C. Lindquist)
- 2) Acquire Adobe Acrobat 5.0 for generating new series of lists on Web Site (C. Lindquist)
- 3) Review Bibliography contents and access to papers on-line with IEEE Editorial Staff (C. Lindquist)
- 4) Continue with conversion of archive documents to digital format (F. Martzloff)
- 5) Continue to enhance rules and set time limits for getting documents submitted to SC 3.2 without jeopardizing completion schedules for the documents (F. Martzloff, J. Koepfinger, D. Jackson)
- 6) Provide E-Mail addresses of all participants to Frank Waterer so he can provide follow-up information on definitions presented.
- 7) Review C62 standards for definitions that are not presently included in any of the dictionaries. (C. Lindquist)

I thank all attendees for their participation. The SC 3.2 Subcommittee will need 3 hours for the Fall, 2001 meeting.

Carl E. Lindquist

Chairman  
SPDC Subcommittee 3.2

### 3.3/4/5 High Voltage Surge Protective Devices – S. Hensley

Minutes of HVSPD Subcommittee Meeting  
St. Pete Beach, Florida  
May 17, 2001  
Steve Hensley, Chairman

1. Attendance at the meeting:

Members: Steve Hensley (Chair), Michael Comber, Bob Hileman, Volker Hinrichsen, Dave Jackson, Bengt Jonnerfelt, Gerald Lee, Dennis Lenk, Ken Nolan, Joe Osterhout, Tom Rozek, Rao Thallam, Arnie Vitols, Larry Vogt, Jim Wilson, Michael Champagne

Guests: Mark Drabkin, Phil George, Don Schleicher, and Charlie Williams

2. The meeting was called to order at 2:00 p.m.

3. There were 16 members and four guests present.

4. The fall 2000 minutes were approved as written.

5. Joe Osterhout introduced a motion to require minimum number of practical tests on an arrester that will ensure performance in 95% of all applications. Denny Lenk seconded the motion. In the discussion that followed, it was decided to send it to the A&S subcommittee for review. The motion will also be posted on the web site.

6. Working group chairs were reminded to provide the minutes of their respective meetings to the subcommittee chair within two weeks with a roster spreadsheet as a separate file.

7. Working group meetings were held for:

3.3.11	Continuous revision of C62.11	Tom Hartman
3.3.13	High Voltage Characterization & Testing	Ken Nolan
3.4.8	Protection & Insulation Coord. of Transformers	Eva Tarasiewicz
3.4.9	Surge Protection of AC Machines C62.21	Dave Jackson
3.4.14	High Voltage Application Guide C62.22	Reigh Walling
3.4.16	Separation Effects	Jim Wilson

8. Key Points from review of working group minutes include:

**W.G. 3.3.11 – Continuous Revision of C – 62.11**

Steve Hensley – Acting Chairman

**Task Force #1 - Proposal of Energy Based Arrester Rating Standard**

Mike Comber – Chairman

Mike Comber reported from the last W.G. meeting that the charge for this TF was to make a recommendation to the WG for a new energy based arrester classing/rating system similar to the IEC rating system of 1 – 5. That is making a recommendation to WG whether or not such a rating system should be developed.

The TF has a fairly decent outline of how to proceed. This past April a first draft report was put together by this TF to proceed with developing such a rating classification system. Some concerns to be addressed are the users understanding of such a new rating system as compared to the present IEEE system of classifying arresters. Parallel to this work a similar group needs to address this issue within the Application Guide to address this issue. This TF may meet after this W.G. meeting to continue this work.

Jon Woodworth stated he is opposed to using energy ratings to classify distribution type arresters. A paper will be presented to the PES Summer Power Meeting stating why energy ratings should not be used (I squared x t) to describe distribution type of arresters. Jon further stated energy capability is not an issue of concern until 230 kV systems with long lines are involved. This should be addressed in the Application Guide. Jon recommends we just describe a test method to measure the energy ratings so the claimed capability would be consistent among all manufactures and types of arresters. Jon further stated we need to describe an energy-

based test by which energy could be measured, is easily repeatable, and is easily performed by many existing lab facilities. Also the system described should be easily understandable. This was echoed by Bob Hileman.

Again the next activity (should a new rating system be pursued), would be to develop the standard test and develop the standard rating system and classifications to be used.

**Task Force #2 – Review of Insulation Withstand Tests**

This task force now is active as TF – 7 in W.G. 3.3.13

**Task Force #3 – Disconnecter Operation, TCC Review**

This task force now is active as TF – 8 in W.G. 3.3.13

**Task Force #4 – Creation of Statement of Purpose Paragraph for Each Design Test**

Chairman – Jon Woodworth

This TF put together a list of the attributes of arresters and which tests in the C-62.11 Standard actually measure or demonstrate those attributes. This list was circulated among the entire WG and discussed. Some of this discussion may actually be more aligned with an Application Guide. A statement of purpose of each test is still needed in C – 62.11 for each test. In general these tests are designed to prove an arrester can survive certain phenomenon and therefore be able to do perform it's intended purpose of protecting other equipment and the entire electrical system to which it is connected from over-voltages. The group consensus is that such a paragraph for each test would be a worthwhile venture and provide useful information. Additionally, the scope statement of C – 62.11 could provide a general statement of what an arrester does (as stated above). Comment was also made that the issue of what tests are relevant to what arrester design and should this be taken to A & S as to what long term strategy should be pursued. That is, what tests currently in the standard should be kept either in their present form or in some updated, modified form. Jon Woodworth asked for some direction from the WG – do we still need a “statement of purpose for each test”? Reply from Acting WG Chair – take comments from today's meeting and pursue a “statement of purpose for each test”. Submit a draft to the WG by the next meeting in Fall 2001. Section 6 of the Standard might be the place to place which tests verify the specific arrester attributes which are referenced below.

**1<sup>st</sup> Attribute – Voltage limiting (clamping) capability** – This attribute is covered by the impulse current discharge voltage capability (Discharge voltage characteristics, impulse protective level voltage time characteristics).

**2<sup>nd</sup> Attribute – Impulse Current Discharge Capability** – Surge currents of all magnitudes and waveshapes must be discharged repeatedly to ground while in the process of limiting the voltage across it's terminals. This attribute is measured by HCSD, LCLD or TLD, and ODC tests. Comment was made that all these tests are currently run on all types of arresters and this is a waste of testing for certain class of arrester.

**3<sup>rd</sup> Attribute – Power Frequency Voltage Withstand Capability**

**4<sup>th</sup> Attribute – Mechanical Force Withstand Capability**

**5<sup>th</sup> Attribute – Electrical Insulation Withstand Capability**

**6<sup>th</sup> Attribute – Controlled and Post Failure Capability**

**7<sup>th</sup> Attribute – Power System Capability Attributes**

**8<sup>th</sup> Attribute – Environmental Withstand Capability**

Other attributes from the WG members should be submitted to Jon Woodworth for inclusion in the next draft.

**Task Force #5 – Creation of a “Hot” HTML Version of C – 62.11**

Jody Levine nor Tom Hartman attended this meeting so no report was given.

**Task Force #6 – Short Circuit Tests**

Bengt Johnnerfelt to present IEC version in our Fall meeting. Note, this Task Force moved from W.G. 3.3.13.

**Task Force #7 – Partial Discharge Proposal**

This proposal was approved in W.G. 3.3.13 and is now transmitted into W.G. 3.3.11 for editing and inclusion into the next revision of C – 62.11. Tom Hartman to transmit this proposal to the Working Group for editorial comments before the Fall 2001 meeting.

**Task Force #8 – C – 62.11 – 1999 Review** - Scope, to clarify number of samples, ratings required, or any other such information needed to clarify or increase understanding of test descriptions and requirements for Design Tests.

Chairman – Michael Champagne

Contributing Members – Jody Levine, Joe Osterhout, Mike Comber

**Purpose** – Come up with questions on test procedures which may be asked by the “novice” in order to clarify any statements in the existing Standard which may be ambiguous. The Chairman of this Task Force will begin this process by reviewing the existing design tests and create a list of questions for review and discussion.

Michael Champagne handed out the first draft of issues documented so far. The WG was given 15 minutes to review this document and then discussions began. Any further issues in this regard, raised by other WG members should be sent to Michael Champagne

In paragraph 8.17.3 of the Standard – Joe Osterhout mentioned we will reconcile this issue as we are proposing to rewrite the Short Circuit Test procedure. Mike Comber mentioned even issues raised that required clarification only should not be forgotten, but verbiage clarifying these issues should be included in the next revision of the Standard.

In paragraph 8.11.1.4 the twenty second operation was clarified to be interpreted as the operation after the 21<sup>st</sup> operation. This information needs to be provided to the editorial phase of this Standard revision. This motion by Joe Osterhout was seconded by Paul Lindemulder and the motion was carried by the WG. This would complete the work of TF – 8 pursuant to any further submissions from other WG members. This work will be placed in the Members only section as accepted work to be included in the next revision of C – 62.11.

**Old Business** – The last 62.11 Standard was published in 1999. Therefor a timeline needs to be established for WG 3.3.11 to have the next revision ready for 2004 publication.

**New Business** – A Par shall be written and submitted for the next revision of C – 62.11 for the Fall 2001 meeting. Steve Hensley is open for volunteers and nominations for a new Chair for WG 3.3.11 to replace Tom Hartman who has left to pursue interest in the LV area of SPD.

Jon Woodworth brought up the issue of reviewing the existing Standard to look at the attributes of the arrester and therefore what sorts of tests are needed to demonstrate each of these attributes and the environments within which an arrester must survive and perform. Mike Comber reinforced this examination process and proposed a new TF be created to deal with this issue. Again this needs to be approved by A & S and HVSPD with a clear goal and scope. This scope may be beyond a TF and may require an entire WG and a substantial period of time to complete. Steve Hensley will discuss this issue in HVSPD.

### **3.3.13: HV Characteristics and Testing: Ken Nolan, chairman**

3.3.11 does not currently have a PAR. Therefor 3.3.13 which works under the direction of 3.3.11 is working without a PAR. Steve Hensley read indemnification statement to WG. We do not have indemnification from IEEE until there is a PAR. A PAR will be written this week and submitted on Friday.

#### **T.F. – 1 Short Circuit Testing –Bengt Johnnerfelt**

Members – Joe Osterhout, Tom Hartman, Mike Comber, Steve Hensley, Ken Nolan, Ed Foelker, John DuPont, Volker Hinrichsen

Bengt will submit the IEC draft to us this fall. Bengt currently has the responsibility to submit this next draft to IEC.

Joe Osterhout explained some of the expected changes and details in IEC proposed draft. In the two source method (pre-failing the blocks) time delay between failing the blocks and applying short circuit current didn't seem to matter after pre-failing if at least 30A was applied as the short circuit current. Made testing much more repeatable.

Next Joe Osterhout, Bengt Johnnerfelt and Volker Hinrichsen discussed the magnitude of the asymmetrical current offset for the reduced voltage test. The consensus of the entire W.G. is a magnitude of 2.5 is still virtually impossible to achieve.

Bengt Johnnerfelt requested help to find out what a proper and reasonable offset should be based upon readily available laboratory restraints. Denny Lenk suggested that some manufacturers should have data that they might share. Joe Osterhout suggested we ask NEMA. Ken Nolan will make this request.

Bengt Johnnerfelt will bring his proposed draft to the fall meeting and the manufacturers data will be pursued to present to the WG some parameters with which we may reasonable work within pertaining to asymmetrical offset. Jon Woodworth. asked for clarification on direction for this TF. Ken Nolan explained there was an attempt to align with the existing IEC proposal. However the IEC can not reach a consensus opinion on a normative document. Discussions ensued regarding IEC's efforts and progress within our TF. It was determined to wait for Bengt's next draft, NEMA lab data and incorporate into a document for the W.G. to review. The W.G. will not wait any longer for an IEC approved normative document. The TF will come up with a suggested use document for the W.G. to review.

#### **T.F. – 2 Energy Capability – Temporarily inactive**

#### **T.F. – 3 Transmission Line Arresters – Jeff Williams Temporarily inactive**

#### **T.F. - 4 Partial Discharge Proposal – Mike Comber Activity complete – passed on to W.G. 3.3.11**

**T.F. – 5 Moisture Ingress –**

Chairman - Ken Nolan

Members – Joe Osterhout, Paul Lindemulder, Ed Foelker, Eva Tarasiewicz, John DuPont, Bert Parsons

Ken passed out copies of Draft 6 for discussion.

The Goal of TF – 5 was reviewed: The purpose was to create a new moisture ingress test for polymer housed arresters and align with the IEC, if possible. We have taken the original IEC proposal and adopted some changes on the IEC procedure. Additionally, we are including the MDCL static test within the moisture ingress proposal.

Discussion of series-parallel connected combination arresters ensued. It was mentioned it is very difficult to calculate the mechanical forces on a single unit. It was agreed it is better to test a complete unit. However, based upon laboratory limitations lengths over 800 mm can be difficult to cycle through the temperature processes required.

Discussions ensued regarding the 800 mm length and also the use of the graphic concerning the foot-print of the mechanical unit.

It was suggested that we define “polymer housed arresters”, which we are addressing here. The current IEC definition will be forwarded as a suggested definition: “arrester using polymeric and composite materials for housing with fittings. Note – Designs with enclosed gas volume are possible. Sealing may be accomplished by use of the polymeric material itself or by a separate sealing system.”

The question came up as to whether this test should apply to ceramic housings. For the present this question shall remain open.

Line 49: Shall be re-written as follows: Discharge voltage at not less than 0.01 x the nominal discharge current.

Line 51: delete PD test.

Line 110 and 111: delete “in a vessel”. Similar editorial suggestions should be sent to Ken Nolan.

**T.F. – 6 Polymer Aging –** Chairman - Steve Hensley

Members – Arnie Vitols, Bengt Johnnerfelt, Joe Osterhout, Volker Hinrichsen, Tom Hartman, Mike Comber, Tom Rozek

The objective of this T.F. was to include a multi-stress test in the document.

Steve Hensley handed out copies of Section 8 and reviewed the changes made from the last meeting.

Some editorial changes were discussed.

Section 8.6.3.1: Steve will reword the current draft attempting to make it sound more as a design test and aligning with ANSI. Also, if an arrester passes the heavy pollution or contaminated environment test this shall be the only test required (i.e. the 1000 hour test would not be required if an arrester can pass any described 5000 hour test.).

IEEE 1313.2 Table 4 ESDD references porcelain. IEEE Std. 4-1995 covers ESDD for polymers. Ray Hill to send Steve Hensley a copy of IEEE Std. 4-1995 section covering ESDD.

Section 8.6.3.3: Much discussion ensued concerning evaluation of the test results. Note 1 goes into the text. Note 2 was deleted. A few other editorial comments will be made. The substantive content of this document is substantially complete.

**T.F. – 7 Insulation Withstand –** Joe Osterhout

Activity differed to 3.3.11

**T.F. – 8 Disconnecter Operation –** Chair open

Temporarily inactive

Larry Vogt updated the W.G. on arrester mounting bracket failures. In the last two years, FP & L has had around 30 brackets fail each year after disconnecter operation. This phenomenon occurs only on their 23kV system. Flashovers occurred across the top of the bracket and would puncture the fins on top. Pole fires have occurred in some cases where ground was not readily available. Bracket failures have not occurred on 13.8kV systems. FPL uses a longer bracket (125kV BIL) now with success. An older design bracket has not had a problem. Many of the failures have occurred inland (15 miles from the sea) and not necessarily on the coast. Therefore, severe environmental conditions may not necessarily be a factor here. Possibly this type of failure may have been going on for years with many utilities. An EEI questionnaire has been sent out and the only other utility reporting similar failures was Florida Power Corporation. It was noted that brackets were never intended to be permanent insulators providing full line insulation.

Larry Vogt and Ken Nolan will submit a proposal to W.G. 3.3.14 for possible inclusion in next revision of Application Guide.

New Business

Joe O. suggested that the WG as next task take a look at the document (C62.11) as a whole and review the tests to determine if some should be removed or modified. It was noted that the number of tests has probably doubled in the last couple of decades. (See his motion in the beginning of this meeting).

#### **3.4.14. HV Arrester Application Guide Reigh Walling, Chairman**

The proposed timeline for the completion of C62.22-2002 was discussed. The Vice-Chair noted that August 31, 2001 is the last date for the task forces to submit to the WG Chair their final corrections and minor revisions to the draft standard. The goal is to discuss and resolve any problems during the fall 2001 meeting so the standard can be out for ballot by December 1, 2001.

The WG was asked to review the revised Section 5.11, Shunt Capacitor Banks, and provide their comments to the Chair.

Dave Jackson reviewed the parts of the guide that applied to the protection of ac machines. His only comments were a few typos, which he will forward to Reigh.

WG 3.4.16 will be finalizing their changes at this spring meeting. The revision will be circulated to their WG members by the end of next week. The finished text will be sent to Reigh by August 31<sup>st</sup>.

The WG was asked to review the revised Section 5.11, Shunt Capacitor Banks, and provide their comments to the Chair.

Dave Jackson reviewed the parts of the guide that applied to the protection of ac machines. His only comments were a few typos, which he will forward to Reigh.

WG 3.4.16 will be finalizing their changes at this spring meeting. The revision will be circulated to their WG members by the end of next week. The finished text will be sent to Reigh by August 31<sup>st</sup>.

Reigh was requested to review the membership list for each TF. Some people have neither attended a meeting in a long time nor provided any written correspondence. Reigh should contact these individuals and ask if they want to be removed from the TF list.

Arnie Vitols was asked to review Table 1 for accuracy.

The remainder of the working group meeting was devoted to efforts of TF 12 – 43, which are summarized below.

#### **TF 12A Coordination Curves**

Eva Tarasiewicz (Chair), A. Vitols, R. Moore, R. Hileman

**Goal:** To write a supplement to C62.22 that includes the new long time coordination point on the coordination curve, and incorporate this into revised PC62.22.

**Status:** IEEE published the key paper containing the new transformer coordination curve in the July 1999 PES transaction. Previously, WG 3.4.8 had filed a PAR to issue an amendment to C62.22-1998 which would be C62.22.2. It was decided to attempt inclusion in C62.22, but WG 3.4.8 will retain its PAR as a backup. Previously, Eva was requested to send a copy of the latest draft to Jim Wilson and John Posey for standards coordination with the Transformer Committee. Eva provided text to Reigh Walling for inclusion into C62.22. Bob Hileman, with assistance from Jeff Williams, will be redoing Table 6. Some of the terms and symbols in this part of the new transformer draft need to be harmonized with the rest of C62.22. The existing volt-time curve, Figure 9, will become generic in nature while the newly introduced curve will be specific for transformers. Bob Hileman will rewrite the sections and provide the revised material to the WG members by 5/25/2001 for comments. After the WG has reached an agreement, the final document will be sent to Reigh by August 31<sup>st</sup>.

#### **TF 21 Arrester Energy Absorption Capabilities**

Rao Thallam (Chair), T. Lim, M. Comber, S. Brewer, E. Tarasiewicz,  
P. Barker, J. Williams, B. Johnnerfelt, A. Vitols, J. Woodworth,  
S. Hensley, J. Case, N. McQuin

**Goal:** To write a section in PC62.22 that offers guidance on how to select an arrester considering energy handling constraints.

**Status:** A significant addition is planned for PC62.22, expanding on the relationship of system conditions to energy, rules of thumb for estimating energy requirements, modeling guidelines, and how to apply energy data. The material was placed in Sections 4.2.4 and Annex X-2. Mike Comber will review Section 5.3.3 to see if any part of Annex X-2 can be incorporated there. Jon Woodworth will provide Rao with a revised Fig. 7. Once the WG finalizes its work, Rao will send the material to Reigh by August 31<sup>st</sup>.

#### **TF 22 Editing**

Reigh Walling (Chair), M. Comber, G. Lee, J. Posey, D. Jackson,  
J. Woodworth, J. Levine

**Goal:** To oversee the organization of PC62.22 and to incorporate text provided by other TF's.

**Status:** Reigh has incorporated all new material received. This TF will become active soon.

#### **TF 23 Distribution Transformer Protection**

Jon Woodworth (Chair), J. Burke, J. Osterhout, S. Brewer, K. Nolan

**Goal:** To add more information in C62.22-200X on the protection of distribution transformers.

**Status:** The TF met after a previous WG meeting and decided that no further work was needed. This task force will remain open at the request of the WG chair, who has offered to contribute an improvement to the wye-delta transformer bank protection consideration.

#### **TF 27 Arrester Clearance Practices and Recommendations**

Steve Hensley (Chair), S. Brewer, A. Vitols, T. Rozek

**Goal:** To evaluate the present recommendation in Section 6.7, and offer more current recommendations based on industry practices in particular for higher voltage ratings.

**Status:** Previously, Steve Hensley had obtained an ABB guide for transmission arrester clearances and distributed it to the Working Group. He presented a table and graph at the previous meeting trying to use the ABB arrester clearance data for the distribution level. His calculations resulted in larger clearances than what is currently in the standard for distribution arresters. The clearances were compared to the NESC. The chair will review the material already in 1313.2. After TF approval, Steve will submit information to Reigh for inclusion in the draft by August 31<sup>st</sup>.

#### **TF 28 Circuit Breaker Protection**

Eva Tarasiewicz (Chair), R. Hileman, J. Williams, A. Lim, S. Hensley

**Goal:** To draft recommendations on breaker protection practices.

**Status:** Draft of material on lightning surge protection of breakers was provided at a previous meeting. Recent emails might result in the material being changed. The TF was requested to iron out the differences and then to submit the final version to Reigh by August 31<sup>st</sup>.

#### **TF 29 Current and Potential Transformer Protection**

Gerald Lee (Chair), and WG 3.4.13

**Goal:** Report results of research on 500kV current transformer failures. Identify if the addition of surge protection can effectively reduce the present failure rate.

**Status:** Previously, Gerald Lee has reviewed his practice and investigated failures in other countries through Doble. From the presented failures, it appears that overvoltages have not been a factor in the reported CT failures, and CTs generally do not need protection dedicated arrester protection. This task force will be discontinued.

#### **TF 30&43 Transmission Line Arrester Application**

Bengt Johnnerfelt (Chair), G. Lee, S. Brewer, D. Jackson, J. Williams,  
J. Burke, E. Tarasiewicz, S. Hensley, A. Lim, A. Vitols, B. Hileman

**Goal:** To draft recommendations on transmission line arrester application practices. The next revision of C62.22 will have line arrester application in a new section, as the philosophy of application substantially differs from protection of equipment.

**Status:** The TF is working on adding a few sentences on protecting GIS with transmission line arresters. Bengt and Larry (TF 43) discussed recently received material from Tom McDermott. These two task forces will be working together to review the new material. The TF members were requested to send their comments to Bengt by June 5<sup>th</sup>. The final product will be sent to Reigh by August 31<sup>st</sup>.

#### **TF 31 Distribution System Characteristics**

J. DuPont (Chair), R. Thallam, D. Jackson, K. Nolan, E. Taylor, J. Case

**Goal:** To add a section to the guide that offers some help to the user regarding how distribution systems characteristics are determined and used.

**Status:** There was no report from this Task Force.

#### **TF 32 Surge Protection of Solid State Devices**

Keith Stump (Chair), R. Thallam, B. Johnnerfelt, J. Koepfinger, T. Compton

**Goal:** To provide a brief paragraph on the nature of arrester application in these devices.

**Status:** Draft 2 of this new material has been prepared by Keith Stump and has been circulated to the TF for review. The material is included in Section 5.15.

#### **TF 33 IEEE/IEC Coordination**

Joe Koepfinger (Chair)

**Goal:** Evaluate the differences in IEC 99-5-1994 and PC62.22.

**Status:** There was no report from this Task Force. No new IEC coordination was identified.

#### **TF 34 Transmission Cable Protection**

Cliff Erven (Chair), G. Lee

**Goal:** Draft new text for PC62.22 to cover cable to GIS termination protection, and review present Section 12.1 for application to all systems.

**Status:** There was no report from this TF at this meeting. Draft text had been previously provided, and were circulated with the Spring minutes. Gerald Lee will look for Cliff Erven PDF and will forward to Reigh.

**TF 35 Series Reactor Protection**

Cliff Erven (Chair), E. Tarasiewicz, G. Lee

**Goal:** Draft new text for PC62.22.

**Status:** There was no report from this TF at this meeting. Draft text had been previously provided, and were circulated with the Spring minutes. Gerald Lee will look for Cliff Erven PDF and will forward to Reigh.

**TF 36 Liaison with Secondary Arrester Application Guide**

Joe Osterhout (Chair)

**Goal:** Watch for conflicts between the High and Low Voltage efforts.

**Status:** Joe Osterhout reported that Draft 6 of the secondary arrester application guide C62.44 in WG 3.6.9 is being reviewed. They were working on Draft 7 at his meeting.

**TF 42 Definitions**

Rao Thallam (Chair)

**Goal:** Review definitions of BIL.

**Status:** Review definitions of BIL, various energy terms, transmission line arresters, etc.

**TF 43 Arrester Protection of Distribution Lines**

L. Vogt (Chair), D. Jackson, J. Woodworth, P. Schaffer, M. Champagne

**Goal:** Selecting appropriate arrester for distribution line insulation protection.

**Status:** A draft entitled "Distribution Line Lightning Performance Considerations" was passed out at the spring 2000 meeting and attached to that meeting's minutes. This TF will work with TF 30 to produce a final product by August 31<sup>st</sup>.

**TF 44 Distributed Resources**

R. Walling, R. Thallam, J. Woodworth, G. Lee

**Goal:** Define potential impact of distributed generation on arrester application.

**Status:** New task force. The 1547 draft contains no discussion of surge protection. This TF needs to be active in this area. Gerald will get the document and ballot comments placed on the SPDC web site.

**TF 45 Series Capacitor Protection**

Gerald Lee (Chair), Bengt Johnnerfelt, Mike Comber, Cliff Erven, Steve Hensley, Eva Tarasiewicz, Arnie Vitols, Tony Lim

**Goal:** SPDC review of IEEE 824 draft 5 on series capacitors.

**Status:** Gerald Lee needs to send comments to Stan Miske.

**3.4.8 Protection and Coordination of Transformers** - Eva Tarasiewicz, chair

**3.4.16 Separation Effects** – Jeff Williams, chair

Bob Hileman was acting chair of both sections and presented their summaries together.

There is a coordination effort between working groups 3.4.8 and 3.4.16, and also with IEEE 1313.2 such as symbols, formulae, etc. The separation group's goal is to protect other equipment besides the transformer and will include application of altitude into the application guide. The initial guide will apply to air-insulated substations, future work will include GIS, un-shielded lines, etc.

**3.4.9 Surge Protection of AC Machines** - Dave Jackson, chair

The working group met with four members and four guests.

The working group's section 5.1.4 insert is complete and incorporated into the draft of C62.22. There are some minor revisions required.

Dave will re-distribute the new material on C62.21 with comments due back September 1, 2001 for compilation ready for the fall 2001 meeting.

The target for balloting is spring meeting 2002.

For Part I- Preliminary draft 10

For Part II – will need PAR extension.

He recommended breaking PAR into two parts and asked Jim Wilson to check to see if splitting an existing PAR is acceptable in general terms.

**3.4.18 Revision/Reaffirmation of IEEE 1313.1 & 1313.2** Gerald Lee, chair

This working group will work to reaffirm IEEE 1313.1 and to decide if they need to reaffirm 1313.2. The working group will apply for a PAR.

9. Old Business – None

10. New Business

Bibliography subcommittee is a clearing house to send new information. The subcommittee will ask for a definition of a polymer-housed surge arrester. The standards coordinator will not process standards to ballot until the bibliography subcommittee approves all new definitions.

Steve Hensley will put out a request to working group chairs to send all definitions (new and existing) to him and the bibliography committee chair to approved.

11. Membership – No changes

12. Organizational – Mike Comber will replace Tom Hartman and the chair of working group 3.3.11 Continuous revision of C62.11.

13. Bob Hileman made a motion to recommend to the A&S subcommittee that a policy be adopted that no material mailed to members not be considered or discussed at the meeting unless that material is mailed at least a month in advance of the meeting. The motion was seconded and forwarded to the A&S subcommittee.

14. Meeting requirements for the fall 2001 meeting are:

Mike Comber	3.3.11	4 Hours
Ken Nolan	3.3.13	4 Hours
Eva Tarasiewicz	3.4.8	2 Hours
Dave Jackson	3.4.9	3 Hours
Tom Rozak	3.4.14	4 Hours
Jeff Williams	3.4.16	2 Hours
Gerald Lee	3.4.18	1 Hour

15. The meeting was adjourned at 3:40 p.m.

## 3.6 Low Voltage Surge Protective Devices - D. Worden

IEEE-SPD 3.6 Low Voltage Subcommittee Meeting

Meeting held on Thursday, May 17, 2001 at 1400 at the Trade Winds Resort Hotel in St. Pete Beach, Florida

**Members:**

Richard Bentinger***	Ericsson Radio Systems
Warren Boxleitner*/**	Boxleitner Group
Chrys Chrysanthou	Telcordia Technologies
Richard Cohen	PANAMAX
Deborah Jennings-Conner***	UL
Tom Conrad***	LEA International
Bill Curry	TYCO Electronics
Bob Davidson*	UL
Doug Dorr*	EPRI-PEAC
James Funke	Cutler-Hammer
Ernie Gallo*	Telcordia Technologies
Gary Goedde	Cooper Power Systems
William Goldbach	Innovative Technology
Andi Haa***	Consultant
Jim Harrison*	Liebert
Ray Hill***	NEETRAC
Pat Howard***	LUCENT
David Hutchins*	PROTEK, Devices

Phil Jones*	ERICO
Willy Kapp*	Joslyn Electronic Systems (Retired)
Joe Koepfinger*	Duquesne Light Company (Consultant)
Benny Lee*	World Products
Al Martin*	TYCO/Raychem
Francois Martzloff	NIST
Mick Maytum	Power Innovations, Ltd
Richard Odenberg*	TRANSTECTOR
Wolfgang Oertel	Bourns CCP
Mike Parente*	MP Technologies
Hans Steinhoff	Joslyn Electronic Systems (Retired)
Don Turner	Corning Cable Systems
Dee Unterweger*/**	Texas Instruments
Matt Wakeham*/**	Leviton
Frank Waterer (Secretary)	Schneider Electric
Don Worden (Chairman)	MCG Electronics (Consultant)

\* Members not in attendance.

\*\* Members departing 3.6

\*\*\* New Members

#### Interested Parties (In attendance)

Savoula Amanatidis	IEEE
Fred Basso	DEHN
Richard Chadwick	DEHN
Joe Gerace	FAA
Andy Ickowicz	IEEE
Dalibor Kladar	Eaton/Cutler-Hammer
Carl Lindquist	SAN-O-Industries
Jayanti Sangani	FAA

#### Agenda:

##### 1. Introduction

An attendance sheet was circulated for each attendee to sign in

##### 2. Agenda:

The Chair distributed a meeting agenda to all attendees.

##### 3. Comments from the Chair

Chair announced that three members depart SC3.6 due to retirement or job changes.

Chair introduced five new members.

Chair requests that each Working Group Chair read a copy of the PAR for each document under review at the beginning of each Working Group Meeting. Chair requested comments from the floor. Gary Goedde was in favor of the request. Bill Curry indicated that he thought that it was the discretion of the individual Working Group Chair as to whether the PAR is read during a meeting. Bill's concern was that it might take away from valuable meeting time.

Chair explained that this procedure should be considered as a tool for the WG Chair to orient visitors and interested parties as to the scope of the work in progress. It will help to keep the meeting focused on the proper subject material and permit the Chair to terminate discussion on non-related material.

##### 4. Reading of the Minutes:

Minutes from last meeting on October 5, 2000 in Cincinnati, Ohio. Motion to approve minutes of the last meeting was made. Motion was seconded. There were no negative votes.

**5. Comments from the Chair.**

- Each Working Group Chair was requested to submit the number of hours needed during Spring 2001 Meetings to conduct activities.
- In order to satisfy the requirements of indemnification, each Working Group must have an up to date listing of all members. Membership list should include names, company affiliation, and business telephone, FAX, and E-MAIL addresses.
- Each Working Group Chair should provide the SC3.6 Secretary with a list of all who attended the meeting, including Interested Parties and Visitors.
- Chair requires of each Working Group a listing of the status for completion of each standard under development or reaffirmation.

**6. Other Topics:**

- Bill Goldbach is the new IEEE Standards Coordinator for LV Standards and Jim Wilson is the new IEEE Standards Coordinator for HV Standards
- Bill Goldbach requested a listing of E-MAIL Addresses for all members and copy of minutes from each Working Group Meeting.

**7. Summary of Working Group Report:**

WG 3.6.1 Low-Voltage Gap Type Protective Devices - H.Wolfgang Oertel, Chair

- Working Group met for approximately two hours at 1300 on Wednesday, May 16<sup>th</sup>.
- Six members and ten Interested Parties attended the meeting.
- Working Group completed the revision of changes in Draft No. 1 of PC62.32. Document is ready for balloting after changes have been incorporated.
- Working Group will meet in October 2001 to discuss the future of C62.31 (Gas Discharge Tubes). This document will be up for reaffirmation or revision in 2003. All Interested Parties and Working Group Members were encouraged to review the document prior to the next meeting and be prepared to discuss any necessary changes. At the next meeting the Working Group will prepare a PAR that will outline the necessary changes or additions to C62.31.
- Working Group requires four hours during the Fall 2001 SPDC Meeting. Meeting time should be arranged such that members can also attend a meeting of Working Group 3.6.3 on same day.

WG 3.6.2 Low-Voltage Solid State Protective Devices - Mick Maytum, Chair

- Working Group met at 0800 on Monday, May 14<sup>th</sup>. Eight members and nine Interested Parties attended the meeting. The topic was C62.33.
- Reviewed minutes from the last meeting. The homework assignments and new contributions for rewriting C62.33 were reviewed and discussed.
- Dalibor Kladar of Cutler-Hammer wrote a test plan that would possibly replace the Rated Peak Single Pulse Transient Current Test (section 4.5) of the document. This procedure was a hybrid of UL1449 and NEMA LS-1. Suggestions were given to (1) include time limits on the testing, (2) rewrite the procedure to make it more general and encompass all the sizes and configurations of MOVs, and (3) revisit the leakage current requirements of the document. Dalibor requested that some of the MOV manufacturers make the necessary changes to the document. Walter Miller of Maida and Bill Travis of Littlefuse were given the assignment. The assignment is due for completion by August 2001.
- Walter Miller presented a survey of MOV manufacturers terms and definitions compared to the terms and definitions in C62.33. Clamping Voltage was discussed first, and it was decided to keep definition

and symbol as currently shown in the document. The name and definition for 2.3.2 was changed and rewritten as follows:

Peak Single Impulse Current (Varistor): Current that may be applied for a single specified impulse without causing device failure.

- The definition of varistor voltage was then discussed. The standard currently has two definitions for varistor voltage, one that is generic, and the other very specific. The group thought that only one definition was needed. An assignment was given to a task group consisting of Walter Miller, Benny Lee, Al Martin, Bill Travis, and Carl Lindquist to write a definition and evaluate the test method for varistor voltage. The task group will start by Al Martin sending a draft of the definition of varistor voltage to the group. The assignment is due for completion by August 2001. The group and the chairman thought the survey was useful, so it was requested that Walter Miller complete the survey for next meeting. The survey should not only include just terms and definitions from the MOV manufacturers, but also include specification sheets.
- Working Group met again at 1300 on Tuesday, May 15. Eleven members and seven Interested Parties attended the meeting. The topics were C62.37, C62.37.1, C62.33 and C62.35
- The chairman started the meeting by asking the group if they thought C62.37, Standard Test Specification for Thyristor Diodes, needed revision or reaffirmation. The group voted to reaffirm the document. The chairman will submit another PAR to start the process in motion. It was also brought to the group's attention that C62.37.1 will be published shortly.
- The agenda of the meeting was to finish the C62.33 homework assignments left over from the previous meeting, then start reviewing Benny Lee's revision of C62.35 (Items 3 and 4). The discussions went as follows:

Al Martin talked about a new section he wrote on an Insertion Loss Test. The test is designed to determine the effect when varistors or SPDs that contain varistors are added to a high frequency system. The group searched for and found a definition about insertion loss in the IEC dictionary. The definition had to be modified by replacing the word "network" with "SPD". A note at the end of the definition will say, "SPD may also be SPD component." Other items to modify include:

The paragraph talking about impedance should be modified to reflect the application (e.g. communication, data transmission, power line, etc.).

The insertion loss formula will have to be modified to use power instead of voltage. Figure 1 needs to be modified to reference load impedance.

Suggested measuring equipment will be added to aid the reader with insertion loss measurements.

- Tom Conrad discussed his homework assignment. The following items were discussed or suggested:

Section 4.8 and 4.9 was suggested to remain unchanged.

Section 4.7, Rated RMS and DC Voltage Tests, Tom recommended reducing the number of hours of testing by raising the temperature. He will investigate the matter further by providing more detailed procedure that will be discussed next meeting. This assignment will be submitted by August 2001.

Section 4.6, Lifetime Rated Pulse Currents Tests, had suggested changes. The most significant change was to define failure criteria for the test. Tom also explained how pulse duration versus number of pulses might also be able to be used to determine pulse life.

An exercise was given to Bill Curry of Littlefuse and Dave Connett of EPCOS to determine how the pulse life curves were obtained for their company's catalog. They will give a short presentation next meeting.

- Benny Lee presented the changes to C62.35. These changes are summarized as follows:

All of the symbols representing the diodes need to have a solid black body. Some of the symbols in the diagrams still were represented by the varistor symbol.

The title of the document needs to be changed to Test Methods. The chairman will change the PAR.

Some of the Avalanche parameters need to be changed to proper form. The main change is representing the subscript with upper case letters. The chair will review the parameters and send the recommendations to Benny. The chair will also send a copy of the parameter cross-reference table that he generated for the IEC to everyone in the group.

Benny will send the updated copy (draft 5) of C62.35 to all the group members by the end of August 2001.

Al Martin will submit his updated insertion loss test to Benny by August 1, 2001 to be included in the document.

Don Turner asked if James Funke of Cutler-Hammer could submit a definition and explanation of the definition for impulse response time. The chair granted the request, which will be discussed next meeting.

- Two-four hour sessions are requested for the Fall 2001 SPDC Meeting.

#### WG 3.6.3 Low-Voltage SPD Application Guide Don Turner, Chair

- Working Group met for one hour beginning at 1500 on Wednesday, May 16<sup>th</sup>. Six members and thirteen Interested Parties attended the meeting. The principle topics were C62.42 and C62.43.
- C62.43-1999 is published, mature, and is being up-dated by Working Group 3.6.7. Since the Chair of WG 3.6.7 is receptive to the idea, it was recommended that responsibility for C62.43 be fully vested in WG 3.6.7. Approval by Subcommittee 3.6 is requested.
- C62.42 -1992 is published, but is about to be replaced with the component SPD Application Guide.
- PC62.42 , D9 - April 1999 covers Gas Tube, Air Gap, MOV, and Silicon Avalanche Components. The document does not cover Thyristor SPD Components which is included in C62.37.1 - 2000.

The draft document has been balloted, and the remaining negative ballot is being resolved through the receptiveness of Working Group 3.6.2 to review the use of terms "response time" and overshoots" as parameters of MOVs and ABDs. It may be possible to remove these terms as parameters and move the discussion of such terms to a "things-to-watch-out-for" level.

Former Chair Bob Davidson indicates that he has a few figures remaining to be converted to an electronic file format. Current Chair will work with Bob Davidson and Bill Goldbach to see that this is completed in the next few months. The document will then be submitted to IEEE for publishing.

- It was discussed and agreed that Working Group 3.6.3 would continue to maintain C62.42. Working Group will consider any other ideas for application guide work that may be brought up by its members or referred to the Working Group by SC3.6.
- No time is being requested for the Fall 2001 SPDC Meeting.

#### WG 3.6.4 Surge Characterization on L-V Circuits H. Steinhoff, Chair

- Working Group met for four hours beginning at 0800 on Monday, May 14<sup>th</sup>. Six members, fourteen Interested Parties, and two guests attended the meeting. The principle topics were the status of balloting for PC62.41.1, PC62.41.2, and C62.45 as well as current revisions C62.48.
- Francois Martzloff suggested that we begin meetings by reviewing the PAR for whichever documents are on the agenda.
- Bill Goldbach as Low Voltage Standards Coordinator desires meeting minutes from each WG.

- The Minutes of the last meeting were passed out for review. The Minutes accepted as written with no negatives.

- General Business

Joe Koepfinger discussed the PAR for dot 45. He is of the opinion that the PAR was changed unofficially from a guide to a recommended practice. There was a change in office from John Posey to Bill Goldbach. John Posey sent a letter to Bill Goldbach discussing changing the PAR. Francois Martzloff stated that the WG had a consensus that Dot 45 should be a Recommended Practice. Joe Koepfinger stated that he believes the change never went to A&S. Much discussion ensued. Don Worden indicated that the issue needed to be taken care of in SC3.6 rather than the Working Group. Don Worden also supports reviewing the PAR(s) at each meeting.

- Balloting on Trilogy Report - Hans Steinhoff

On December 4, 2000, the first ballots started coming in without instructions. The many difficulties encountered with electronic ballots were discussed. Balloting was extended three times in order to attain the required 75% response. The required number of responses were finally attained and all balloting was closed on Feb. 26, 2001. All three documents received the required 75% approval of the responding parties.

C62.41.1 received 28 affirmative, 9 negative votes, and no abstentions.

C62.41.2 received 27 affirmative, 9 negative votes, and no abstentions.

C62.45 received 28 affirmative, 9 negative votes, and no abstentions.

Discussion and comments ensued.

- BRC Report - Ray Hill

Balloting closed on documents C62.41.1 and C62.41.2 on February 24, 2001. For document C62.45, balloting closed on February 26, 2001.

Out of 46 eligible people in the balloting group, 37 responded to C62.41.1 and C62.45, while 36 responded to C62.41.2. All three documents received the required 75% approval.

Electronic balloting proved to be quite a challenge, not only for the balloters, but also for the Ballot Resolution Committee.

The Editor has already incorporated the editorial comments. The committee members have commented on most of the balloters' comments. In a few weeks, the BRC will have finalized the results. The BRC intends to have the recirculated ballot finished and the completed documents delivered to the Standards Board in time for their September meeting.

Much discussion ensued.

- Bibliography Report - Mike Hopkins

The material from the Trilogy has been sent to the Bibliography Committee.

- C62.48:

Copies of Draft 3 were passed out. There were 4 negatives on the balloting when the document was circulated for reaffirmed. Hans Steinhoff contacted the negative balloters and resolved the negatives.

James Funke summarized the changes for Draft 3. Additions and modifications were discussed. All parties should submit further comments to James Funke.

Action items for document

1. Lines 240-244 will be changed with the figure to reflect concerns. Frank Waterer will implement.
2. James Funke said he will update the membership list in document.
3. Section 5.1: "combination-type SPD"; will check if definition is in IEEE 100. Mike Hopkins to check.

4. Section 5.2: needs word-Smithing. Ken Brown and Alan Rebeck will work on rewording.
  5. Section 5.3: James Funke will reword.
  6. Section 5.4: cut and paste error; needs rewrite. The Editor will review.
  7. Section 5.9: Dave Jackson to make attempt to find reference B10 on Line 589.
  8. Section 5.9: Francois Martzloff will provide input discussing voltage magnification for this section.
  9. Section 6.3: Alan Rebeck will rewrite the last paragraph.
- There was no new business.
  - A four hour session is requested for the Fall 2001 SPDC Meeting.

WG 3.6.6 L-V AC Power Circuit Protective Devices D. Dorr, Chair

Working Group met for four hours beginning at 1300 on Tuesday, May 15<sup>th</sup>. Nine members, eleven Interested Parties, and five guests attended the meeting. The principle topic of meeting was final revisions to Annex D of PC62.72. PC62.72 is nearly ready for balloting.

1. Introductions.
2. Comments from the Chair
  - PAR for PC62.72 has been extended to July 2002.
3. Review of previous minutes from Cincinnati, Ohio on October 3, 2000. Motion made to accept minutes. There were no negative votes.
4. C62.72 Task Force Chairman began review of Draft No. 11. Focus of the review focused primarily on submission to "Keywords" and revisions made to Annex D.
  - Don Worden, Francois Martzloff, Hans Steinhoff and Tony Surtees to conclude work on potential revision to Section 13.1 (Suppressed Voltage Ratings) to include wording to coordinate with IEC. This work is a completion of work intended to be concluded before this meeting. Francois Martzloff to pilot the task. Work to be completed by May 31, 2001.
  - Alan Rebeck will submit two separate and brief paragraphs that will discuss the application of SAD and Zener Diodes.
  - Francois Martzloff does not want references to Zener Diode contained in the body of the document.
  - Hans Steinhoff submitted a handwritten addition for Section 15.3. Editor will review and type the addition for distribution to the Working Group. Hans will submit a reference relative to the use of circuit breakers with SPDs for Annex B of PC62.72.
  - Editor will submit all definition to be used in PC62.72 to SC3.2 for their review.
  - Editor to develop a list of "keywords" for distribution to the members for their review and comments.
  - Editor will perform a word search of the document to identify every location where the term "TVSS" is used in the documents.
  - Secretary to send out request for a Balloting Pool for PC62.72. Chair began the process by distributing a roster to collect names of those interested in balloting PC62.72. Completed list will be forwarded to Bill Goldbach (Low Voltage Standards Coordinator).

- Editors received a list of editorial comments from Ted Dhooge and James Funke.
- Chair solicited names for membership in a Ballot Resolution Committee for PC62.72.

5. Additional Comments

- Francois Martzloff wants the PAR for each document under review to be read aloud at the beginning of each meeting.
- Francois Martzloff requested that all future documents be sent via E-MAIL in a "pdf" format.
- Alan Rebeck requested clarification of the differences between C62.62 (Performance Standard) and C62.45 (Test Standard). Don Worden provided clarification. (C62.62 started as a performance standard and emerged as Standard Test Specifications.)

6. New Business

- Chair will draft a PAR for revisions to C62.62.
- Motion: Members to be given copies of C62.62 prior to the PAR. Discussion: Along with a copy of C62.62 document, FDM wants members to have a copy of NEMA Document VS-1, and IEC 61643-1 prior to creating the PAR. Motion withdrawn. Chair assigned task as an action item. Chair will attempt acquire a copy of IEC61643-1
- Chair requested members to be looking ahead for topics and technical issues to be addressed by Working Group 3.6.6.
- A four-hour session is requested for the Fall 2001 SPDC Meeting.

WG 3.6.7 L-V Data, Communication, And Signaling Circuit SPD Bill Curry, Chair

The Working Group met for 4 hours Monday, May 14<sup>th</sup> with 7 members and 12 interested parties in attendance and again for 4 hours Wednesday, May 16<sup>th</sup> with 4 members and 18 interested parties in attendance.

- Work continued on revision of C62.43-1999 "Guide for the Application of Surge Protectors Used in Low-Voltage (Equal to or Less than 1000 Vrms or 1200 Vdc) Data, Communications, and Signaling Circuits". Fifteen contributions were received and discussed.
- The disposition of Standard C62.64-1997 was addressed by the WG and the decision made to revise the standard. A PAR will be prepared during the Fall, 2001 meeting.
- The WG resolved to request IEEE for a certificate of recognition for retiring member Dee Unterweger to be presented on behalf of WG 3.6.7.
- Two- four hour sessions are requested for the Fall 2001 SPDC Meeting.

WG 3.6.9 Performance Standard for L-V SPD (Secondary Arresters) G. Goedde, Chair

Working Group met for four hours beginning at 1300 on Monday, May 14<sup>th</sup>. Nine members, sixteen Interested Parties, and seven guests attended the meeting. The principle topic of meeting was the final revisions to PC62.44. PC62.44 is nearly ready for balloting.

1. Introductions and distribution of agenda.
2. Comments by secretary on new sign in sheet and the distribution of minutes via E-MAIL.

3. Review and approval of the agenda.
4. Francois Martzloff requested that the PAR for each document under review or editing to be read at the beginning of each meeting.
5. Chair introduced Bill Goldbach as the IEEE Standards Coordinator who will coordinate the balloting of C62.34 (IEEE Standard for Performance of Low-Voltage Surge-Protective Devices (Secondary Arresters))
6. Francois Martzloff requested that a list of action items for work or contributions by attendees to be summarized at the end of all recorded minutes.
7. Chairman distributed minutes from last meeting, and presented a draft (IEEE PC62.44- Draft 4, May 2000) of document for review by the committee. Attendees reviewed minutes from previous meeting held in Cincinnati, Ohio on October 2, 2000. Motion to accept minute. Motion seconded. No negative votes.
8. Chair distributed copies of IEEE Guide PC62.44/Draft 6 for review. The title of the document is "Guide for Application of Low-Voltage (1000 Volts rms or less) Surge Protective Devices Used on Secondary Distribution Systems (between the Transformer Low-Voltage Terminals and the Load Side of the Service Entrance Panel). Remainder of meeting consisted of the review of document.
  - Joe Koepfinger wants the term "secondary arresters" added to the title of the document.
  - Joe Koepfinger wants the line 103 to include 25Hz power systems.
  - David Jackson suggested that definition 3.6 (Secondary Arrester) be changed to read "load side terminals of the main service entrance panel".
  - Frank Waterer suggested that definition 3.6 be revised to read "main service entrance equipment".
  - David Jackson indicated that if the definition for "Secondary Arrester" changes, then the title and the PAR will require changing.
  - Line 199 will read "*Formerly* Computer and Business Equipment Manufacturers Association". The term "CBEMA Curve" will remain in the document.
  - Line 214: Alan Rebeck wants paragraph 4.3 "Protection against overvoltage resulting from" to be reconstructed as Section 5.0 "Origins of Surges".
  - Joe Koepfinger want line 230 to provide clarification that the reference to the value of 40kA 8/20 $\mu$ s to be referenced to the environment or a test specification. Joe wants the values to be justified. Joe will submit revisions to editor. FDM suggest that values be referenced to C62.41.1 when it is published.
  - Relative to Figures 3a and 3b, Joe Koepfinger wants the figures expanded to provide additional clarifications of the current flow of the surge currents. Existing figures will be broken up and expanded to show detailed current flow via individual scenario.
  - There was much discussion between Joe Koepfinger, David Jackson, and Francois Martzloff regarding the figurative representation and references to an air terminal chamber. David Jackson provided editor with a drawing indicating a potential design
  - Line 212: Francois Martzloff suggests that a footnote be applied after the word "coordination" which explains whether the word refers to interaction coordination or cascade coordination.
  - Line 248: Joe Koepfinger suggests that the word in 4.3.3 regarding swells should read exactly as the wording proposed for swell in the revisions to C62.48 from WG3.6.4.
  - Section 5.2.2: The term "utility" will be revised to read "energy service provider" where applicable.

- Line 302: The phrase "National Electrical Code Article 280" will be revised to read "Authorities Having Jurisdiction"
- Line 298: Sentence will include "qualified personnel".
- Section 5.2.2: There will be a section "E" added to include "Sub-Panels" with a sub-category of "out buildings".
- Motion: (by Hans Steinhoff) **"Do not add an "Item E" to paragraph 5.2.2, remove outbuilding from Figure No. 1, and remove the outbuilding from Figure No. 6, and references to sub-panel from all figures because they extend beyond the scope of the document."** Motion seconded. There were no negative votes.
- Motion: (by Dave Jackson) **"Under 6.3.5 that there be language that the application of arresters in sub-panel is covered in C62.72 which in process"**. Motion seconded. There were no negative votes.
- Editor will revise paragraph between lines 308 to 312 to clarify language regarding the protection of arresters that are only applied between one line or phase and ground or neutral. All ungrounded phase conductor to be protected.
- Joe Koepfinger indicates that IEC is requiring that Secondary Arrester have an over current protective device in series with the secondary arrester. Joe will contribute a new paragraph in section 5.2.2 to address the needs and specification of over current protective device.
- A four hours session is requested for the Fall 2001 SPDC Meeting.

WG 3.6.10 Combined Multi-Port SPDs R. Cohen, Chair

- I. Introductions from the Chair. Chair provided a status of the document of development. Chair reviewed agenda items for considerations by the membership. Chair wants membership to consider methodologies to get the document released for publication. Chair expresses hope to update the draft of the document underdevelopment with the intent to complete document as soon as possible. Chair intended to guest and Interested Parties that the proposed audience for the document will be for electrician, architects, and others that are not very technically inclined. Chair distributed copies of a draft copy of "OUTLINE OF THE PLANNED IEEE GUIDE FOR SURGE PROTECTION OF EQUIPMENT CONNECTED TO AC POWER AND COMMUNICATION CIRCUITS". Secretary distributed copies of the minutes from the last meeting.
- II. Chair circulated a copy of IEEE "Blue tooth" Publication (How to Find What You Need in the Bluetooth™ Spec) for review by membership.
- III. Chair reviewed proposal for potential alternative methodology to get the publication to press.
- IV. IEEE SA suggested that document be published as a guide without the IEEE logos. Question from membership as to whether or not the alternative publishing methodologies exclude the legal cover extended to IEEE Working Groups.

Bill Goldbach asked if the document could be issued as an IEEE Technical Report. IEEE indicated that publishing methodology suggested for the document does not include the document being released a technical report.

A small peer review group will be formalized for the review of the document.

Chair requested opinion from the membership if a "Bluetooth" type publishing methodology is acceptable to the body of the membership. There were no negative comments or opposition.

FDM wants the reading of the PAR document at the beginning of each Working Group Meeting.

Chair indicated to the membership that IEEE-SA will be appraised of all publication plans for the document and will plan to acquire their concurrence prior to the document going to press.

Bill Curry, as an interested party, suggested and recommended that the working group first developed a more formal and technically thorough and comprehensive document prior to developing a brief application guide. Chair responded that there was a consensus of the membership to develop the brief guide first. Chair indicated that there will be a proposal at the Fall 2001 Meeting to develop a more conventional IEEE Document for the Application of Multi-Port Protectors.

- V. Review of the minutes from the past minutes in Cincinnati, Ohio on October 4, 2000.

Motion made to accept the minutes. Motion seconded. There were no negative votes.

- VI. Chair began a review of the proposed graphics to be incorporated into the document.

**A. Figure No. 1:**

1. Grounding conductor for pole mounted transformer will be identified.
2. AC Unit and Satellite Dish will show an equipment grounding conductor that is bonded to the same grounding electrode.

**B. Figure No. 2:**

1. A neutral carrier line will be shown on the power pole that will be located below the overhead phase conductors.
2. "Grounding Electrode" will read "Building Grounding Electrode".
3. The Primary Telephone Protector will be drawn within a rectangular box to represent a Network Interface Device (NID).
4. Second sentence in the figure description will be changed to read; "***The CEC and NEC<sup>®</sup> required grounding via effective bonding means of the electrical service to an appropriate grounding electrode***".

**C. Figure No. 3:**

1. Grounding conductor on top of roof will be shown in the apex of the roofline.
2. A NID will be drawn to the left of the three surge protectors located below the Load Center.
3. The grounding conductors below the house will be identified as the "Grounding Electrode System".
4. The wording "lightning rod structure" in figure description will be change to "air terminal".
5. The word "enhanced" in the figure description will be removed.

**D. Figure No. 4:**

1. The SPD associated with the meter can will be relocated to the load side of the kWh Meter.
2. The line text will be bolder for all lines representing grounding leads.

**E. Figure No. 5:**

1. Existing Device "C" will be removed. Existing Device "B" will be relabeled as Device "B or C"
2. Frank Waterer to provide revised schematic.

**F. Figure No. 6:**

1. Frank Waterer to provide revised diagram to show  $\emptyset$ -N connections of protector.
2. Fuses and surge components in existing figure will be incorporated into a single hard-wired protector.
3. First sentence in figure description will be changed to read, "Hardwire vs. plug-in protector".
4. Francois Martzloff wants a third figure that distinguishes separates (?) in-line fuse for all MOVs vs. an individual fuse for each MOV.

**G. Figure No. 7:**

1. The labeling of Devices "A" and "B" will be respectively exchanged. The Service Entrance Panel will be identified as "B" and the COAX Protector will be identified as "A".
2. Ted Dhooge, Richard Cohen, Francois Martzloff, and Frank Waterer will revise drawing. Revised drawing will be forwarded to Chuck Richardson. Richard Cohen to lead the task.

**H. Figure No. 8:**

1. Existing Figure No. 8 will be relabeled as Figure No. 9.
2. The wording "Basic configuration" in the beginning of the first sentence will be changed to "Plug-in configuration".
3. The surge protective components will be represented in the figure by a rectangular box.

**I. Figure No. 9:**

1. Existing Figure No. 9 will be relabeled as Figure No. 10.
2. The word "to" associated with the input side of each protector will be removed.

**J. Figure No. 10:**

1. Existing Figure 10 will be relabeled as Figure 8.
2. The voltage values of 1000-100,000V will be changed to 10,000V.
3. Graphic image will be mirror imaged

VII. Secretary will forward a copy of member's E-MAIL Address to each all members and interested parties.

VIII. Chair reiterated that all correspondence, drafts, and submittals are openly circulated via E-MAIL to all members.

**8. Summary of requested working group time for next meeting:**

There was general consensus that the schedule of meeting times created for the May 2001 meetings should be repeated during the October 2001 Meetings

WG3.6.1 Working Group requested four hours during the next meeting.

Working Group requested that meeting time should be arranged such that members can also attend a meeting of Working Group 3.6.3 on same day.

WG3.6.2 Working Group request eight hours during the next meeting.

Working Group requested two meetings of four hours each on different days.

WG3.6.3 Working Group does not request any meeting time during the next meeting.

WG3.6.4 Request 4 hours at the next meeting.

WG3.6.6 Request 4 hours at the next meeting.

WG3.6.7 Request 8 hours at the next meeting  
Working Group requested two meetings of four hours each on different days.

WG3.6.9 Request 4 hours at the next meeting.

WG3.6.10 Request 4 hours at the next meeting.

#### 9. Reports of Related Standards Activities.

Bill Curry voiced concerns over the procedure to get an IEEE Standard that his Working Group has prepared to become an ANSI Standard. SC3.6 Chair advised Bill Curry to coordinate with Bill Goldbach on a letter to or through IEEE requesting that ANSI re-ballot C62.36. We believe that ANSI balloted before the IEEE delegation was instructed on how to vote. This is a problem with the ANSI / IEEE parallel balloting.

#### 10. Old Business

Chair announced that there will be a new Article 285 in the 2002 Edition of the NEC<sup>®</sup> that will specifically address Transient Voltage Surge Suppressors with the acronym "TVSS". Chair asked the 3.6 Subcommittee if this creates a need for SPDC to define "TVSS". It was noted that a TVSS definition is under discussion in WG 3.6.6.

Chair requested that new definitions, created in the various Low Voltage Working Groups, be brought to SC3.6 for concurrence prior to forwarding to SC3.2 for review and addition to the PES/SPDC list of definitions.

Motion: SC3.6 Secretary to distribute to the membership a copy of the definition of the TVSS as it will appear in the new NEC Article 285 and the proposed definition of TVSS as proposed in PC62.72. Secretary will request a response from the membership within thirty day. Motion Seconded. There were no negative votes.

- List of all current members is required from all Working Groups.

#### 11. New Business

Motion: Transfer responsibility for C62.43 from Working Group 3.6.3 to Working Group 3.6.7. The motion was seconded. There were no negative votes. (It was generally accepted that this change will simplify the coordination between the Application Guide and the Standard Test Methods documents and accelerate the standards making process.)

- Carl Lindquist, Chair of SC3.2 (Definition / Biography), has initiated a new methodology to document new definitions. Carl has request that the Working Groups submit proposed definitions that are new or being revised to SC3.2 for review. Chair requested that Carl send an E-MAIL to all Working Group Chairs asking for their input.

#### 12. Closing Comments

Chair announced retirement as Chair of SC3.6 and offered closing comments and thanks to all for their many contributions, loyal support and enthusiasm over the years. All attendees warmly accepted the Chair's comments and closing words. Chair announced that A&S is considering several candidates for the Chair of SC 3.6. It is anticipated that the next chair will progress through all of the SPDC chairs which translates to roughly a ten year commitment

#### 13. Next Meeting

The next meeting will be held at the Marriott Hotel, Niagara Falls, Ontario, Canada on Thursday, October 4, 2001. Meeting concluded at 1540

## 4.0 Special Activities – J. Woodworth

- Luncheon Presentation at Spring 2001 Meeting  
At the Spring 2001 meeting. Charlie Williams from Florida Power Corp. presented a report on the worst lighting storm of the Century. It occurred in the Tampa/St Petersburg area and caused a record number of outages on the Florida Power Corp system. The presentation resulted in numerous questions and discussion.
- Fall 2001 Meeting in Niagara Falls  
In place of the luncheon meeting, a tour of the Robert Moses Power Plant will take place.

## 5.0 IEC Activities - J.L. Koepfinger

### REPORT TO IEEE SPDC, ASC C62 AND IEC TC 37, SC 37A and SC 37B TAGS St. Petersburg Beach, FL 13-18 May 2001

#### IEC Activities

##### Working Group 4

##### IEC 60099-4 Amendment 2 - Part 4: Metal-oxide surge arresters without gaps for a.c. systems

The editing committee met in Geneva in November 00 for 3 ½ days to review the comment on 37/231/CDV and to prepare the FDIS. Members of the editing committee are Prof. Asle Schei, Volker Hinrichsen, Fredrick Malpiece, Michael Comber, Michele DeNigris, John Gauthier, and Joe Koepfinger. There has been considerable delay by the IEC Central Office in the issuing of this FDIS. It was to have been released by the first quarter of 2001. As of this writing it is still not issued. It is expected that it will be issued before the end of May. The National Committees have a two months' voting period. If the document is approved, it is the intent of the writing committee to take the material and revised it into a format that is consistent with the format proposed by IEC TC 37 Working Group 12. All material common to the various surge arrester technologies will be organized into one section of the new document. This will consist of definitions and tests common to all technologies. Then for each technology there will be an additional section. Only those items that are particular to that technology will be contained in these separate sections. For test common to all technologies, reference will be made to the first section.

This will be a major effort, but it will be the beginning of a better organization of the IEC TC 37 standards.

##### **Working Group 11 Harmonization of terms and definitions in the documents of technical committee No. 37 and its subcommittees 37A and 37B**

They have prepared 37/267/CD TC 37, IEV CHAPTER 456 Surge Protective Devices. This document was circulated on 5 May 2001 to the National Committees. In the initial document, no effort has been made for harmonization of terminology between the three committee documents. The most significant contribution of this material is the establishment in the IEV of a section pertaining to surge protective devices. All of the members of the TAG are urged to download the document and prepare comments to be sent to J. Koepfinger before 15 August 2001.

##### **Working Group 9 Amendment to 60099-4, Part 6: Metal-oxide surge arresters containing both series and parallel gapped structures for a.c. systems**

This document, prepared by Working Group 9, was circulated as 37/261/CDV to the National Committees in February 2001. The ballot is now closed and the comments for the document are contained in 37/266/RVC. The document was approved by the National Committee for the the FDIS stage. Mr. Woodworth was given a copy of the comments. An editing committee is to be formed. The date of the editing committee meeting will be discussed during this meeting with the convnor, Mr. Woodworth.

##### **Environmental Aspects of Surge Protective Devices**

The IEC Advisory Committee on Environmental Concerns has been successful in requiring that the Strategic Policy Statement (SPS) of the Technical Committees contain a statement regarding what the technical committee is doing to address the environmental compatability of products covered by IEC product standards. TC 37 indicated in their SPS that they initiated a study of this topic. Dr. DeNigris, the President of TC 37, has undertaken this task. He has advised me that he has developed some information regarding HV surge arresters.

Depending on how some of the material in the surge arresters is disposed of, there may be some environmental considerations that will need to be considered in the standard. It is suggested that the US needs to address this issue and, if possible, prepare a report that can be submitted to TC 37.

This same issue needs to be considered by SC 37A and SC 37B. The US should develop a position on this topic for low-voltage surge protective devices.

### **SC 37A Low-Voltage Surge Protective Devices**

#### **SC 37A has three working groups,**

1. WG 3: Selection and application principles for low-voltage surge protective devices
2. WG 4: Surge protective devices connected to telecommunications and signalling networks
3. WG 5: Performance and Test methods

#### Working Group 3

All of the Working Groups have been extremely active. Working Group 3 met in London, UK on 19-20 March 01. During this meeting, the convenor, Mr Alain Rousseau, reviewed the result of the Committee of Actions deliberation of a question raised by TC 64 on the need for 61643-12 Selection and application of low-voltage surge protective devices. The committee of action agreed with the position of SC 37A that this document did not conflict with the work of TC 64 Working Group 3. They agreed that the work of TC 64 covers installation of electrical equipment in buildings and the selection and application does not construe installation. With this action 61643-12 has been moved to the FDIS stage. TC 64 wanted this document to be issued as a technical report and not as a standard.

TC 64 is to be invited to the next meeting of SC 37A/WG 3. The convenor reviewed the minimum requirements in TC 64

The Convenor reviewed parts of 64/1168/CD as it may impact upon 61643-12.

#### a) Table 2 Minimum requirement of SPD dependent upon system voltage $U_c$

The Convenor noted that the value of  $U_c$  is shown in the table as equal to 1.1 time  $U_o$ . This compares to a value given in the current edition of IEC 60364-5-53 which is 1.5 times  $U_o$ . The use of the lower value is based upon the Withstand Capability of the SPD as defined in IEC 61643-1.

#### b) Clause on TOV

##### **534.2.3.3 Selection with regard to temporary overvoltages (TOVs).**

The SPDs selected according to 534.2.3 are expected to withstand the temporary overvoltages due to faults within low voltage systems (see IEC 60364-4-442), and they shall withstand the test of IEC 61643-1.

#### c) Short circuit current

##### **534.2.3.5 Selection with regard to the expected short circuit current**

The short circuit withstand of the SPDs shall be equal to or higher than the maximum short circuit current expected at the point of installation. In addition, when a follow current interrupting rating is declared by the manufacturer, it shall be equal to or higher than the expected short circuit current.

SPDs connected between the neutral conductor and PE, which allow a power frequency follow up current after operation (e.g. spark gaps), shall have a follow current interrupting rating  $I_F = 100$  A.

There is a problem with clause as related to IT system according to the Convenor

#### d) Use of SPDs

##### **534.2.1 Use of SPDs.**

When required in accordance with IEC 60364-4-443, or otherwise specified, SPDs shall be installed near the origin of the installation or in the main distribution assembly, closest to the origin of the installation inside the building.

When required in accordance with IEC 61312-1, or otherwise specified SPDs shall be installed at the origin of the installation.

Additional SPDs may be necessary to protect sensitive equipment. Such SPDs shall be coordinated with the SPDs installed upstream (see 534.2.3.6).

In the case where SPDs are part of the fixed electrical installation, but not mounted inside a distribution board (e.g. socket outlet) their presence shall be indicated by a label on or as near as it is reasonably possible to the origin of the considered circuit.

IEC 60364-4-443 includes protection against overvoltages of atmospheric origin (caused by indirect, distant lightning strokes) and switching overvoltages. This protection is normally realized by installation of test class II SPDs and if, necessary, test class III SPDs.

IEC 61312-1 includes the protection against the effects of direct lightning strokes or strokes near to the supply system.

IEC 61312-3 describes the correct selection and application of SPDs according to the Lightning Protection Zones concept. The LPZ concept describes the installation of test Class I, test Class II and test Class III SPDs

e) Measurement of the insulation is a new requirement.

**534.2.7** Measurement of the insulation resistance

During the measurement of the insulation resistance of the installation according to IEC 60364-6-61, SPDs installed near the origin of the installation or in a distribution board and not rated for the test voltage of the insulation measurement may be disconnected. In the case where SPDs connected to PE conductors are part of a socket outlet, they shall withstand the test voltage for measuring the insulation resistance according to IEC 60364-6-61.

**7. Preparation of future joint meeting of WG3 and WG4 in Toronto,, June 2001 and in particular study of:**

The convenor addressed the need to coordinate the work of SC 37A/WG 3 and WG 4. To accomplish this a joint meeting is to be held in Toronto, CA on 11-15 June 2001 between WG 4 and WG 3. WG 4 will meet on 11-12 and WG 3 will meet on 14-15 June 2001. On Wednesday, 13 June there will be a joint meeting of WG 3 and WG 4. The prime consideration is the harmonization of 61643-12 and 37A/111/CD, 37A/111/CD: Draft 61643-22 Ed. 1.0: Surge Protective Devices connected to telecommunications and signalling networks-Part 22: Selection and application principles. The following is an example of some additional material that was discussed.

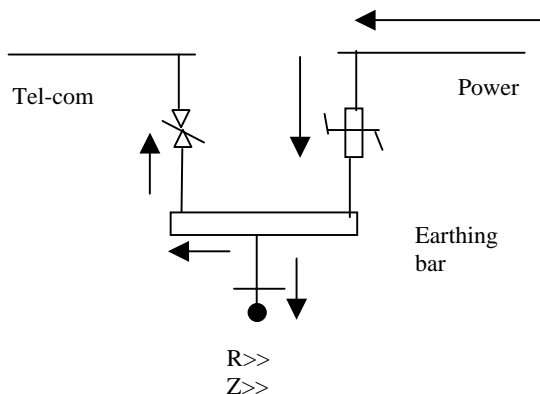

**FIGURE 1**  
Path of Lightning Current for Local Earth Impedance  
Greater than Impedance of Telecom shielding circuit earthed every 300 meters.

Figure 1 is used to illustrate what would occur if direct lightning stroke current was impinged upon the power system and the telecommunication earthing system impedance was lower than that of the local earth. In this case the lightning stroke current would divide two ways at the earthing bar in the inverse ratio of the local earth impedance to the telecom remote earth. This would force current through the telecom protectors and have the potential of overstressing these SPDs and causing their failure with the potential of damaging other equipment connected to the telecom system.

There are several test conditions that need to be considered:

- a) Isolation via insulation between power and the communication side to withstand stresses that would be placed on the power side. Are special tests needed? Surge withstand test may be needed to test withstand between the two different ports.

WG5 Maintenance Item pertaining to Amendment 1 of 61643-1 clause 6.2.13 contains a requirement that states the manufacturer must declare the insulation with time between the ports. There is no test associated with this requirement, it provides the bases for the need for a test.

- b) Is there a need for special tests procedures with regards to surge withstand and to TOV? It was agreed that there is a need for a TOV tests. Other tests may be needed.
- c) For single SPD used for protection of telecom and a single SPD used for power protection that are arranged to provide both telecom protection and power protection there is no need for special tests.

Mr. Koepfinger questioned this position in light of the discussion of Figure 1.

Mr. Bachl question whether or not there should there be a solid barrier between the telecommunication input and the power input to a device that contains both protection to the telecommunication system and a power circuit SPD in one container.

**ACTION:** This subject will be handled by Maintenance TF 3 and incorporated in Clause 8. On the 16<sup>th</sup> of April a text will be provided by the Convenor, Mr. Rousseau. Response is due by 18 May 2001. This item will be discussed in Montreal in June 2001.

## 8. Review of TF documents:-

### 8.1 TF: "Annex G2 (text to be prepared)". URGENT need for a TF leader and members to form this TF

In the discussion reference is made to figures G-2 and G-3. The question is how to use this material in IEC 61643-12. The convenor suggested that there are three options: a) drop the annex, b) refer it to a working group or c) refer it to a task force. It was agreed that it should not be dropped. Mr. Bachl suggested that a determination should be made as to what needs to be changed to make it acceptable.

What is missing in 61643-12 as related to 61643-1

- a) Clause 8
- b) Clause G2
- c) Annex A
- d) NC comments
- e) Risk analysis

The changes that are needed to met response from TC 64 should be in the next amendment. It is proposed that Amendment 1 is to include changes as a result of Amendment 1 of IEC 61643-11, which will encompasses, a), b), part of c), d) and e). The remaining material in Annex A is to be covered in the next revision. With regards to Annex A the Amendment is to take care of the tests that have been already developed but not addressed in 61643-12. The Amendment 1 is not to cover new tests on IEC 61643-11. The completion date for Amendment 1 shall have a validation date of 2004.

Project 2. The revision of the exist document to include clauses 4.4.3, 5.3.5 and a new clauses coming from IEC 61643-1 by 2006

Project 3 is to cover SPD used in DC power systems. At the present time this will continue to remain in the zero state.

**ACTION:** Focus as quickly as possible on producing Amendment 1.

**8.2 TF4 Maintenance Team new items after NC comments review**

TF leader = Bernhard Richter  
 NC comments as follows remained to be addressed

45 US a WG3

Clause 4.2 does not provide the characteristics of the equipment to be tested. The convenor agrees with the US position. IEC Joint Working Grp. 31 from TC 64 is producing a Technical Report IEC 62066. "General basic information regarding overvoltages in low voltage power system". This report should be issue in the very near future. Therefore, the decision is to wait until the document is issued. This document contains information on the withstand of the equipment.

**ACTION:** Mr. Bachl will make an effort to have the IEC 62066 posted on the SC 37A Website in Folder on SC37A.

**ACTION:** Mr. Bentinger to determine what requirement are in ITU regarding equipment withstand.

**ACTION:** Koepfinger to secure and send to the convenor the Information Technology Associate curves (CBEMA curve)

**SC 37A Website**

SC 37A has established a Website at the IEC for their committee activities. This is managed by an administrator for WG 3 and WG 5. These are Dr. Brocke, Mr. Richter and Mr. Rousseau.

Working Group 5

Working Group 5 sent the First Amendment to IEC 61643-1 to Geneva to be issued as an FDIS with a two months circulation period. Debbie Salisbury has made available a draft copy to the members of the TAG. SC 37A/WG 5 meet in Cancun, Mexico

The following is a schedule of the work of this working group as prepared by Mr. Bachl.

MAINTENANCE IEC 61643-1

Proj.No. / Item No.	Old item No. (Paris)	Title	Documents/Responsibility	Remarks/Decision
<b>Edit. Corr. ↓ A1</b>	28	7.6.4 Class I and II preconditioning tests	37A WG5 (Spokane/Hasse) 1 <b>SC37A WG5 (Spokane) 17</b> [Brocke, Hasse (Spokane)]	<b>DECISION SPOKANE August 2000</b> New text see document <b>SC37A WG5 (Spokane) 17</b>
1/01	1	Revision of Table 2 (see also CLC-SR37A)	CLC/SR37A(London/Leigh)1 <b>Rousseau</b>	<b>covered by item 27</b>
1/02	2	Add definition for "overshoot"	<b>Bentinger</b>	37A/92A/CC comment 8 from SE  <b>DECISION CANCUN January 2001</b> Proposal before next meeting
1/03	3	All tests where the wooden box with muslin paper is required: Was it really intended to apply these tests to outdoor SPDs mounted out of reach ???	<b>37A WG5 (Mexico) 12</b>	<b>DECISION CANCUN January 2001</b> Email comments to TF-convenor! Definition for outdoor is missing
1/04	4	7.5.3 Sparcover voltage with 1,2/50 – Determination of measured limiting voltage <i>correct e) to read</i> "... the <u>maximum</u> of the 10 measured peak values."	<b>Bachl, Brocke</b>	<b>DECISION CANCUN January 2001</b> <b>Replaced and covered by item 2/07</b>
<b>1/05 ready for CD</b>	5	7.7.2.2 Pass criteria – Temperature rise limits under consideration	Discussion !	<b>DECISION CANCUN January 2001</b>  Modify text to read:  Indoor SPDs: the surface temperature rise shall be less than

				120°C during the test and the temperature drop shall be at least 40 K in 5 minutes after the disconnecter operation., based on the ambient temperature defined in 7.1.
1/06	6	7.7.3 Short circuit withstand capability test + Pass criteria Was it really intended to apply this test to outdoor SPDs mounted out of reach ???	37A WG5 (Spokane) 13 (= Bachl (Spokane) 3) <b>Bachl</b>	proposal: exclude LV overheadline SPDs from this test, but apply to all other types of SPDs  <b>DECISION CANCEL</b> <b>January 2001</b> Email comments to TF-convenor! Definition for outdoor is missing
1/07	7	7.7.4 Modify TOV failure test and apply a power source at Uc after the TOV stress.	SC37AWG5(Paris/Brocke)1 37A WG5 (Mexico) 4 (= SC37A WG5 (Cancun/Bachl) 1) <b>Bachl, Brocke</b>	<b>DECISION CANCEL</b> <b>January 2001</b> Perform tests and finalize proposal before next meeting  See also item 13
1/08	8	7.7.6.1 Superposition of surges and TOV stresses or application of current impulses some 10 ms before the TOV stress	<b>Richter</b>	37A/93/INF comments 14 + 16 from PL
1/09	9	7.8.2 Rated load current There should also be a temperature rise limit for other than touchable surfaces and for the terminals.	37A WG5 (Spokane) 11 (= Bachl (Spokane) 1A) <b>Hasse, Bachl</b>	<b>DECISION CANCEL</b> <b>January 2001</b> Only slight additions to the existing subclause before next meeting
1/10	10	7.9.5.1 and 7.9.5.2, discrepancy between tables 14 and 15	<b>Cantini</b>	
1/11	11	7.9.7.2 and 7.9.8 – Modify test procedure or add a statement to cover SPDs with metal housing connected to the PE-terminal of the main (SPD) circuit.	<b>Karmazyn</b>	<b>DECISION CANCEL</b> <b>January 2001</b> Proposal before next meeting
1/12	12	7.9.8 Reference to IEC 60060-1 needs to be detailed.	<b>Bachl</b>	<b>DECISION CANCEL</b> <b>January 2001</b> Proposal before next meeting
1/13	14	Back filter details	<b>Odenberg, Surtees</b>	see proposal from Rick Gumley, which has been accepted in London / Nov. 1997  <b>DECISION CANCEL</b> <b>January 2001</b> Check with London minutes
1/14 ready for CD	15	Modify test parameters for class I tests	SC37AWG5(Paris/Brocke/3a) Email Tony Surtees 17/07/00 SC 37A WG 5 (Spokane) 15 SC 37A WG 5 (Spokane) 16 CLC/SR37A(London/Leigh)1	<b>DECISION SPOKANE</b> <b>August 2000</b> New text see document CLC/SR37A(London/Leigh)1 Subclauses 3.9 and 7.1.1 amended by a note below table 3: <b>Note: One of the possible waveshapes which meets the above parameters is the 10/350 waveshape proposed in IEC 61312-1/1995.</b>
1/15	27	Take into consideration the draft Common modifications for Cenelec	CLC/SR37A(London/Leigh)1 <b>Rousseau, Bachl</b>	<b>DECISION CANCEL</b> <b>January 2001</b> Distribute copy of the CLC Common mods extract after positive UAP result
1/16	30	7.7.3 and 7.8.3 Short circuit tests Add missing parameters: - Phase angle for switching on - Cross sections and length for test wiring Pass criteria 0,5 mA should only be valid for special or internal disconnectors	37A WG5 (Spokane) 13 (= Bachl (Spokane) 3) <b>Bachl</b>	<b>DECISION CANCEL</b> <b>January 2001</b> Email comments to TF-convenor! Proposal before next meeting

		Aren't 3 operations too much, especially when high rated fuses are used (e.g. 400 A) ???		
1/17	31	7.5 a) and 7.5.4 a) there is a discrepancy: Testing should be done unenergized, because otherwise the generator impedance adjustment together with the decoupling is extremely difficult and time consuming	<b>Richter</b>	<b>DECISION CANCUN January 2001</b> Proposal before next meeting
<b>1/18 a) ready for CD</b>	32	7.7.2.2 b) 2 <sup>nd</sup> paragraph: ... power source having short circuit current high enough to ... What is high enough ??? Depending on the adjustment the result may differ significantly!!!		<b>DECISION CANCUN January 2001</b>  <b>Replace 2<sup>nd</sup> paragraph of 7.7.2.2 b) with</b>  The SPD is energized at $U_C$ by a power frequency source with a short-circuit current capability which will not limit the current before any disconnecter operates. The maximum current value shall not exceed the maximum declared value of the short-circuit withstand capability declared by the manufacturer.  <b>Replace last sentence of 7.7.2.2 a) with</b>  The maximum current value shall not exceed the maximum declared value of the short-circuit withstand capability declared by the manufacturer.
1/18 b)		7.7.2.2 Pass criteria Requirement regarding danger to the surrounding during the test is missing.	<b>Bachl</b>	<b>DECISION CANCUN January 2001</b> Proposal before next meeting
1/19	33	7.8.3 Add circuit diagram(s) for clarification	<b>Bachl</b>	<b>DECISION CANCUN January 2001</b> Proposal before next meeting
1/20	34	7.7.2.2 a) and b) A requirement how to test SPDs with protective components in parallel and having separate disconnectors is missing	<b>Bachl</b>	<b>DECISION CANCUN January 2001</b> Describe problem before next meeting
1/21	35	7.5.2 Residual voltage test Limit max du/dt to avoid problems with SPDs with protective components in parallel, one of them being a sparc gap	Email Tony Surtees 17/07/00 <b>Brocke, Hasse</b>	<b>DECISION CANCUN January 2001</b> Proposal before next meeting
1/22	36	"Short connectors" – flow power capacity	SC37A-WG5-Oct.14,1997/F.Girard F.Girard/SC37A/WG5/Paris/15 <b>TF: Girard, Koepfinger, Rousseau</b>	
1/23	--	Review 6.2.7 regarding RCD exclusion for operating duty test	<b>Rousseau</b>	
1/24	--	List of symbols	<b>Odenberg</b>	<b>DECISION CANCUN January 2001</b> Proposal before next meeting
2/01	13	Modify existing test or new test to cover "low current short circuit behaviour" of the SPD (range 100A to 500A)	SC37AWG5(Paris/Brocke)1 <b>37A WG5 (Spokane) 6</b> (= Brocke (Spokane) 1) <b>Brocke</b>	<b>DECISION CANCUN January 2001</b> Background and proposal before next meeting
2/02	16	New test for 2port SPDs and SPDs with separate input/output Terminals to verify the overload behaviour with backup overcurrent protection.	<b>37A WG5 (Spokane) 12</b> (= Bachl (Spokane) 4) <b>Bachl</b>	<b>DECISION CANCUN January 2001</b> Comments regarding current factors from US, (JP), Proposal before next meeting
2/03	17	New test for coordination purposes (see 37A/97/CDV, 6.2.6.3)	<b>Rousseau</b>	
2/04	18	New test for electromagnetic coupling	<b>Howard</b>	37A/92A/CC comment 5 from US

		between the primary and secondary circuits in the SPD		<b>DECISION CANCEL</b> <b>January 2001</b> Proposal before next meeting
2/05	19	New test for total current for multipole SPDs	SC37AWG5(Paris/Brocke/2) <b>37A WG5 (Mexico) 6</b> <b>Brocke</b>	<b>DECISION CANCEL</b> <b>January 2001</b> Modified proposal before next meeting
2/06	20	New test: Durability versus Degradation	37A WG5 (Spokane) 14 (= Girard (Spokane) 1) <b>37A WG5 (Mexico) 7</b> (= Odenberg (Mexico) 1) <b>TF: Girard, Odenberg, Richter</b>	<b>DECISION CANCEL</b> <b>January 2001</b> Modified proposal before next meeting (combine with preconditioning ?)
<b>2/07</b> <b>ready for CD</b>	21	New test for Front of wave sparkover for voltage switching SPDs	Email Tony Surtees 17/07/00 37A WG5 (Mexico) 3 <b>37A WG5 (Mexico) 8</b> <b>Hasse</b>	<b>DECISION CANCEL</b> <b>January 2001</b> Replace 7.5.3 with <b>37A WG5 (Mexico) 8</b>
2/08	22	New test for Residual du/dt for 2port SPDs	<b>37A WG5 (Mexico) 5</b> 37A WG5 (Mexico) 9 37A WG5 (Mexico) 9A <b>Surtees</b>	<b>DECISION CANCEL</b> <b>January 2001</b> Modified proposal before next meeting (combine with measured limiting. voltage)
2/09	23	New test for Multiple lightning impulse current operating duty	<b>37A WG5 (Mexico) 10</b> (= 37A WG5 (Brocke) 2 Cancun) <b>Richter</b>	<b>DECISION CANCEL</b> <b>January 2001</b> Possible deletion of item next meeting based on 37A WG5 (Mexico) 10
<b>2/10</b>	24	New test / modified test for extended temperature range		<b>DECISION CANCEL</b> <b>January 2001</b> <b>DELETED !</b> See clause 2.2
2/11	25	New test for Insertion loss (frequency response)	<b>Karmazyn</b>	<b>DECISION CANCEL</b> <b>January 2001</b> Combine with item 2/08 Proposal before next meeting
2/12	29	Modifications to properly cover SPDs connected N-PE only Marking of terminals ???	37A WG5 (Spokane) 6 (= 37AWG5(Spokane/Brocke)1) <b>37A WG5 (Mexico) 11</b> (= 37A (Brocke) 3 Cancun) <b>Brocke</b>	<b>DECISION CANCEL</b> <b>January 2001</b> Email comments to TF-convenor! Proposal before next meeting
2/13	--	New test for steep impulse current	37A WG5 (Spokane) 8 (= Koepfinger (Spokane) 1) <b>Hasse, Koepfinger</b>	<b>DECISION CANCEL</b> <b>January 2001</b> Combine with item 2/07 Proposal before next meeting
2/14	--	Impulse failure mode	37A WG5 (Spokane) 21 (= 37A WG5 Spokane (Bentinger)) <b>Bentinger, Rousseau, Surtees, Bachl, Brocke</b>	<b>DECISION CANCEL</b> <b>January 2001</b> Proposal before next meeting
3	26	Test procedures for DC SPDs	SC 37A (Paris/Richter) Richter (Spokane) 1 <b>TF: Richter, Surtees, Rousseau, Hasse, Odenberg, Koepfinger, Murko</b>	<b>TASK FORCE - zero stage</b>
?	--	Define lower current/power limits for SPDs	Discussion !	
<b>NEW 1</b>	--	7.7.4 TOV failure test – 1200 V Modification/amendment to include also pass-criteria for a TOV-withstand of this 1200 V test.	<b>Brocke, Bachl</b>	Requirement from IEC TC64/WG3/PT-27 subclause 534.2.3.3  <b>DECISION CANCEL</b> <b>January 2001</b> Background and proposal before next meeting
<b>NEW 2</b>	--	6.4 Outdoor SPDs shall be ... material that is resistant to UV-radiation, ... Test is missing !		

**SC 37B Surge Protective Devices Components**

SC 37B has two working groups covering the tests specifications for gas tube devices (GTD), Silicon Avalanche Diodes (SAD), Thyristor Surge Suppressors (TSS), Metal-oxide Varistors (MOV).

As of this date, SC 37B does not have any published documents. However the central office of the IEC should be issuing CDVs for MOV and TSS in the very near future.

Submitted by,

J. L. Koepfinger

## 6.0 ASC C62 Activities - J.L. Koepfinger

### REPORT TO IEEE SPDC, ASC C62 AND IEC TC 37, SC 37A and SC 37B TAGS St. Petersburg Beach, FL 13-18 May 2001

#### ASC C62 Activities

ASC C62 was involved in several activities that are of importance to the members and to the IEEE Surge Protective Devices Committee.

They were asked by IEEE to ballot on the following documents.

- IEEE C62.41.1/D4 Guide on the Surge Environment in Low-voltage (1000 V and less ) AC Power Circuits
- IEEE C62.41.2/D4 Recommended Practice on Characterization of Surges in Low-voltage (1000 V and less) AC Power Circuits
- IEEE C62.45 Recommended Practice on Surge Testing and Equipment Connected to Low-voltage AC Power Circuits
- IEEE C62.92.4
- Final review and balloting of revised Operation Procedures.

The IEEE delegation to ASC C62 cast a negative ballot on IEEE C62.41.1, C62.41.2, and C62.45. IEEE, in accordance with the MOU that was signed by IEEE and NEMA, processed the ASC C62 ballot. Each co-secretariat is supposed to notify the other of the results of the C62 ballots that they run. As of the date of the preparation of this report the results of the balloting on the above four documents has not been made known to the ASC C62 Secretary, John A. Gauthier or to myself. This is an ongoing problem. The Chair of ASC C62 prepared a letter to the IEEE balloting service requesting a tabulation of the ASC Ballots on all of the above documents.

ASC C37 is in the process of revising their operation procedures. In their procedures they are proposing that all of the ballots of ASC C37 be run by one organization regardless of who is the sponsor of the documents that is to be sent to ASC C37 for balloting as an American National Standard. This has been discussed with IEEE balloting services. The C37 Operating Procedures were balloted by ASC C37. The ballot on these procedures closed on May 10. The results of this ballot could have an influence on ASC C62 balloting procedures. It is the desire of the three C committees, C37, C62 and C57 to have similar balloting procedures for standards they process for receiving the recognition as American National Standards.

ASC C62 issued an affirmative ballot on the re-affirmation of IEEE C62.92.4

Submitted by,

J. L. Koepfinger

## 7.0 Liaison Reports

7.1 ASC C84 Preferred Voltage Ratings for AC Systems and Equipment- D. Jackson

7.2 Insulation Coordination Projects IEEE 1312 & 1313 (C92.1 & 92.2)- A.R. Hileman

7.3 USNC-IEC Advisory Group to SC28A OPEN No Report

7.4 Transformers Committee- Eva Tarasiewicz No Report

7.5 T&D Committee on Insulator Contamination - M. Comber

7.6 T&D Committee WG on Lightning Performance of Distribution Lines - S. Brewer No Report

7.8 Substations Committee WG E-5 Direct Stroke Shielding of Substation- Open No Report

7.9 T&D Committee: DC & Flexible AC Transmission Subcommittee - Rao Thallam

7.10 T&D Committee Capacitor Subcommittee- C. Erven

7.11 Substations Committee Gas Insulated Substations - G. Lee No Report

7.12 PSI&M Committee High Voltage Testing Techniques Subcommittee - D. Lenk

7.13 PES Awards Committee- R. Odenberg

7.14 T.C. Technical Sessions Improvement Committee - D Lenk

7.15 IEEE/PES Publication Committee - D Lenk

7.16 T.C. Organization and Procedures Committee - D. Lenk

7.17 SCC 18 National Electric Code - C. Chrysanthou No Report

7.18 SCC 23 Dispersed Storage and Generation - Doug Dawson No Report

7.19 SCC 22 Power Quality - S. Whisenant

7.20 IEEE Working Group on Estimating Lightning Performance of Transmission Lines - D. Lenk

7.21 IEC TC 81 - François Martzloff

## 8.0 PES Technical Council Activities - Dennis Lenk

- **Winter 2001 Columbus PES Meeting**

Stan Horowitz is the Technical Meeting Chair for the 2001 WPM. The SPDC is planning to sponsor a paper session at this meeting.

- **Summer 2001 Vancouver PES Meeting**

This meeting will be held July 15-19, 2001. The selected theme of this meeting is Utilization, Reliability, and Control of the Power System-MW and Beyond. Vijay Vittal is the TCPC for this meeting. While topics addressing the theme are encouraged, candidates for proceedings paper on this and other topics are asked to submit their abstracts on proposed papers by Feb. 5, 2001. Authors are required to present the submitted paper as part of a paper session. The paper will be published as part of the PES Proceedings of this meeting.

- **Atlanta T&D 2001**

The 2001 T&D Show is scheduled for October 28 thru November 2, 2001. Kara Clark @ [kara.clark@ps.ge.com](mailto:kara.clark@ps.ge.com) is the Technical Program Chair for this event.

- **Winter 2002 New York Meeting**

John Paserba, the TCPC for this meeting, indicates that the Theme of this meeting will be Embracing the Power of Change.

- **Spring 2002 T&D Conference-Latin America**

This conference is scheduled for March 18-22 in Sao Paulo, Brazil.

- **Proposed Reorganization of the IEEE Power Engineering Society**

The current plan is to leave the technical structure as is but to revise the meeting, conference and expositions as follows.

- One PES General is organized during the Spring of each year. These meetings will not feature any exhibits. The focus would be on technical papers, panel sessions, and tutorials as well as on Committee, Sdub-committee, and task force meetings. The intent of the General Meeting is to provide the meeting infrastructure to gather several Technical Committees under one roof.
- One conference or exhibit will be organized each year during the Fall.
  - During uneven years, the T&D Conference and Expositions will be organized. These expositions will continue to focus on equipment and apparatus aspects of the power industry.
  - During even years, a new event will be organized, possibly restructuring PICA to fill this need.
  - ESMO Conferences will not be affected by this proposed restructuring

A proposed implementation plan would retain present meeting structure thru 2002. 2003 will become the transition year. New structure would be implemented in 2004."

- **The PES reorganized the Technical Council by establishing two new Coordinating Committees during the 2001 Winter Power Meeting.**

Phil Hopkinson has agreed to chair the **Policy Development Coordinating Committee**, whose primary function is to develop policies in all matters in which the dominant factor is the commercial aspects of the Electric Power Industry. This committee will act as the PES coordinating body with other PES technical committees, regulatory agencies, reliability organizations, generating companies, independent system operators, etc. This committee will maintain a high level of cognizance of emerging technologies and develop policies, white papers, and conduct symposia related to such matters.

Brian Gott has agreed to chair the **Emerging Technologies Coordinating Committee**. This committee will act as coordinating and consolidating body with the PES Technical Committees, IEEE Societies, or International bodies that have a particular interest in matters in which the dominant factor is research, development, and application of emerging technologies in the Power Industry. This committee established a Technical Assessment Subcommittee and requested a member from each existing PES Committee. Bill Goldbach agreed to be the SPDC liaison to this subcommittee.

- **Electronic Review of Transactions Papers**

**For the last year, the IEEE Transactions review process has been using e-mail to obtain reviews of submitted papers, replacing the previous snail-mail process. This process has worked well and will soon be taken to a web review process, where the paper will be placed on a web site. Selected reviewers will be given a password so that they can gain access to these papers so that they can perform their review.** Many SPDC members will be receiving Manuscript Central "User ID" and "Password" identification that will allow them to access website papers that they have been asked to review.

- **PE Review Article on the SPDC**

In the November issue of the *IEEE Power Engineering Review* magazine, the SPDC chairman submitted an article describing the SPDC and its activities. The purpose of this article is to introduce the Surge Protective Devices Committee to readers of the magazine. The article described the High Voltage and Low Voltage subcommittee standards writing activity and also discussed the special sessions that we have been sponsoring in our recent meetings. Hopefully, interested readers will be encouraged to attend future meetings and participate in the standards writing process.

Dennis Lenk  
SPDC Chair  
5/17/2001

## 9.0 PES Technical Sessions - Jon Woodworth

## 10.0 Old Business - Dennis Lenk

## 11.0 New Business- Dennis Lenk

## 12.0 SPDC Meeting Schedule – G. Goedde

	Spring Meeting	Fall Meeting
2002	May 13-17, The Tradewinds, St. Pete Beach Florida, (\$131 + tax)	October 7-11, Westin Cincinnati, Ohio
2003	May 10-16, The Tradewinds, St. Pete Beach Florida, (\$139 + tax)	
2004	May 8-14, The Tradewinds, St. Pete Beach Florida, (\$145 + tax)	

The SPDC meeting was adjourned at 5:10 PM.

Respectfully Submitted,

Gary L Goedde  
Secretary, SPDC