

# Stray Voltage Issues

**Keary Dosier**

**Jim Burke**

**Synergetic Design - Raleigh**

# Purpose of Paper

**The purpose of this paper is to address some of the stray voltage issues, we have seen, in the past two years.**

# Topics

- **Terminology**
- **Problems in Identifying Stray Voltage**
- **Mitigation Difficulties**

# Terminology

## Stray Voltage (Historically)

- **Steady State**
- **Neutral-to-Earth Voltage**
- **Associated with Return Current**

# Terminology

## Stray Voltage is NOT

- TOV (Swells)
- Contact Voltage
- Step & Touch Voltage  
(Associated with Fault Current)

# Detection of Stray Voltage

**Stray voltage is very difficult and time consuming to identify and mitigate.**

# Common Points of Stray Voltage Detection

- **Water Faucets**
- **Swimming Pools**
- **Appliances & Equipment Housings**
- **Dairy Farm Equipment**

# Mitigation Difficulties

## Typical Methods

- Larger Neutral
- Better Grounds
- Neutral Isolators
- Etc ...



# Effect of Better Ground Rods

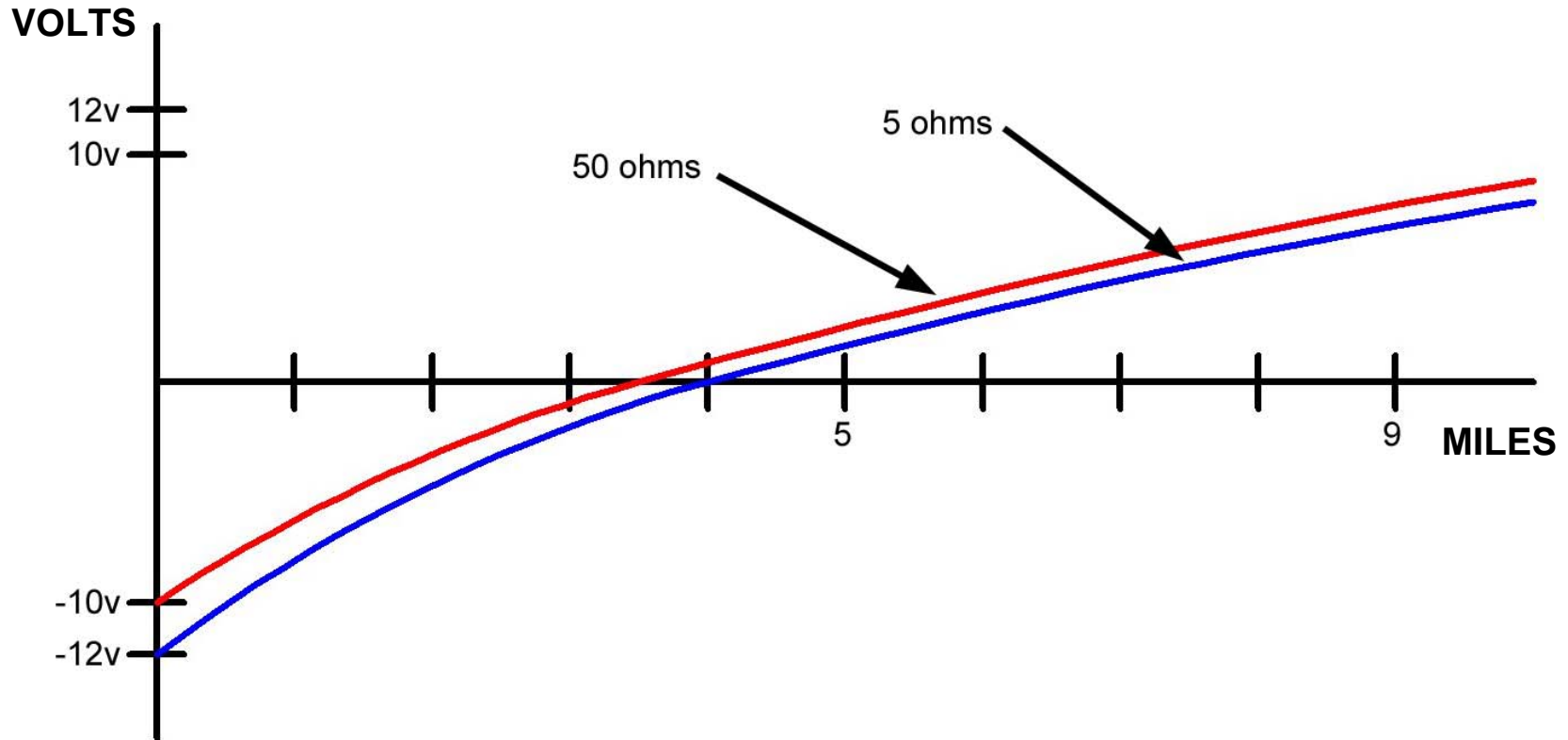

Good grounding has little affect

# Effect of Substation Grounding

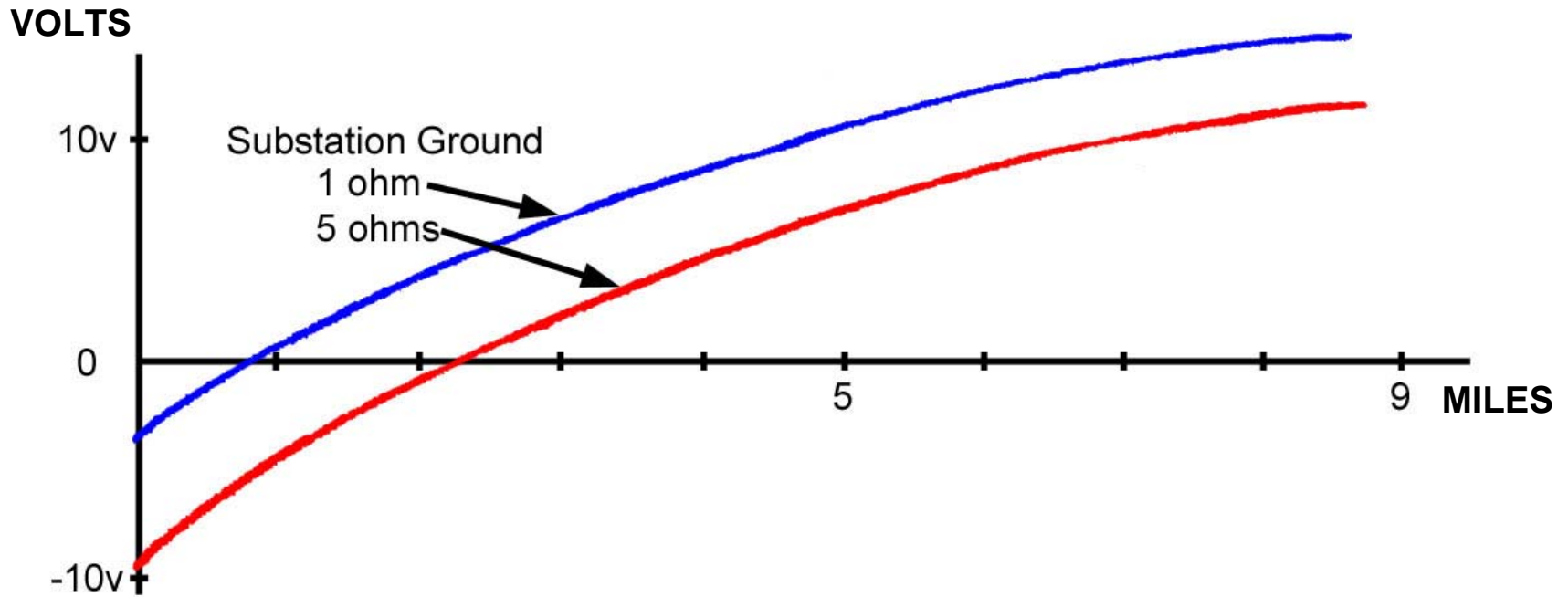

Good grounding helps....sometimes  
Good grounding hurts....sometimes

# Cable Neutral Deterioration

- **Deteriorated neutrals can cause “stray voltages”**
- **Problems with earlierunjacketed concentric neutral cables**
- **Most utilities have switched to jacketed cables**

# Cable Survey

## Stray Voltage Levels Recorded

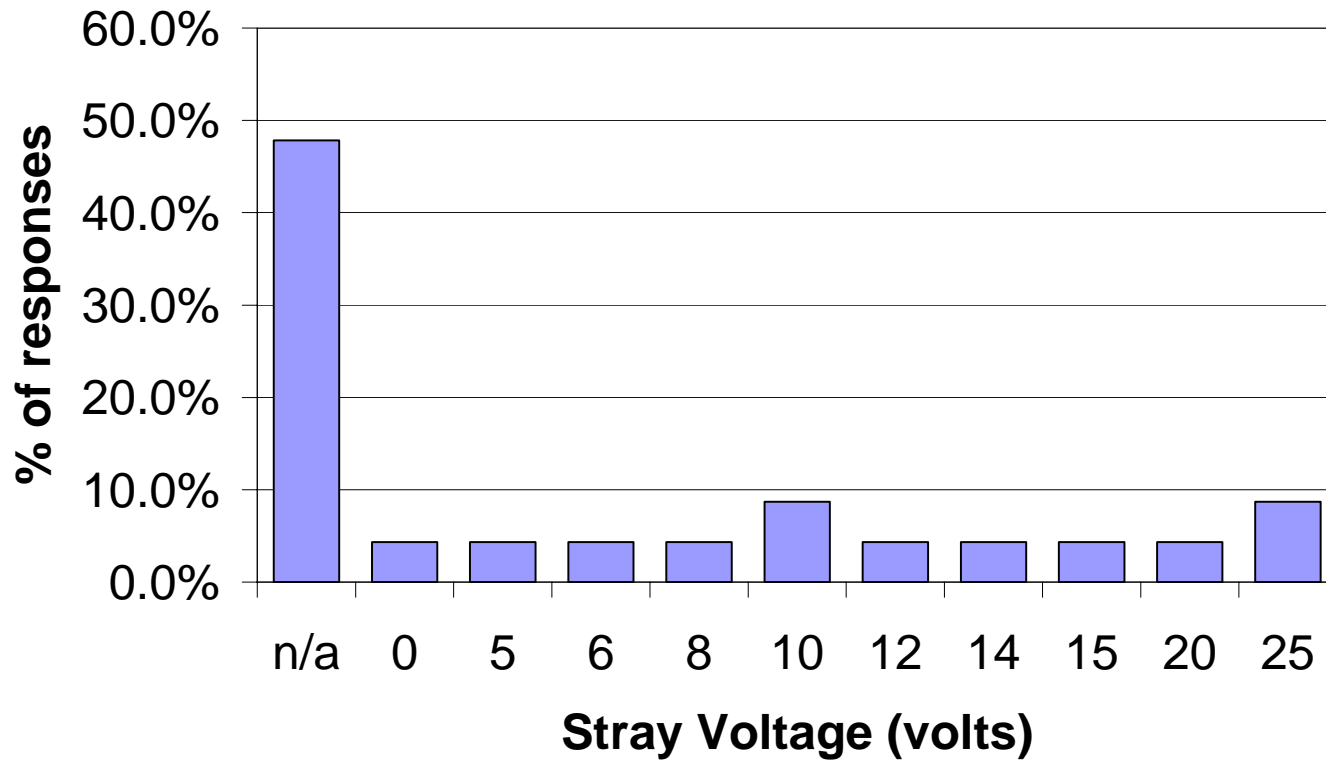

# Complexity of Analysis

Substation with Low Impedance Ground

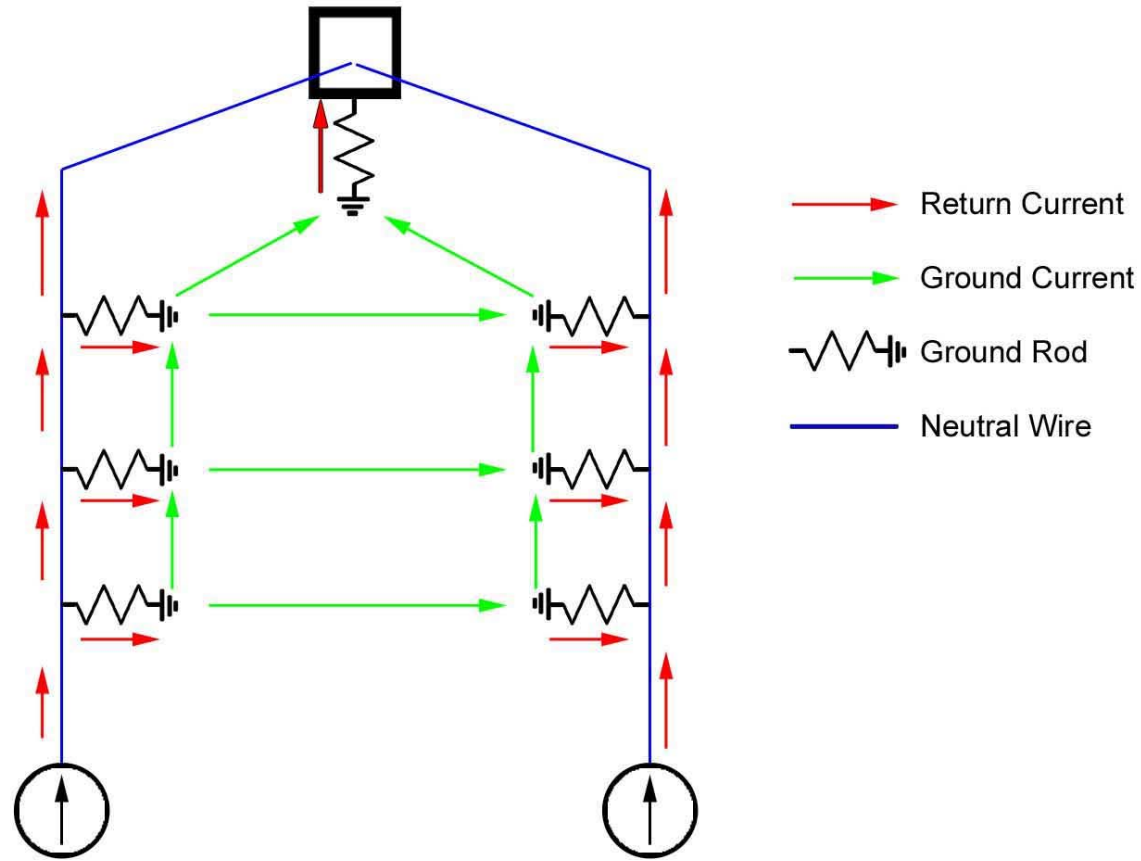

Feeder A Neutral Current

Feeder B Neutral Current

# Complexity of Analysis

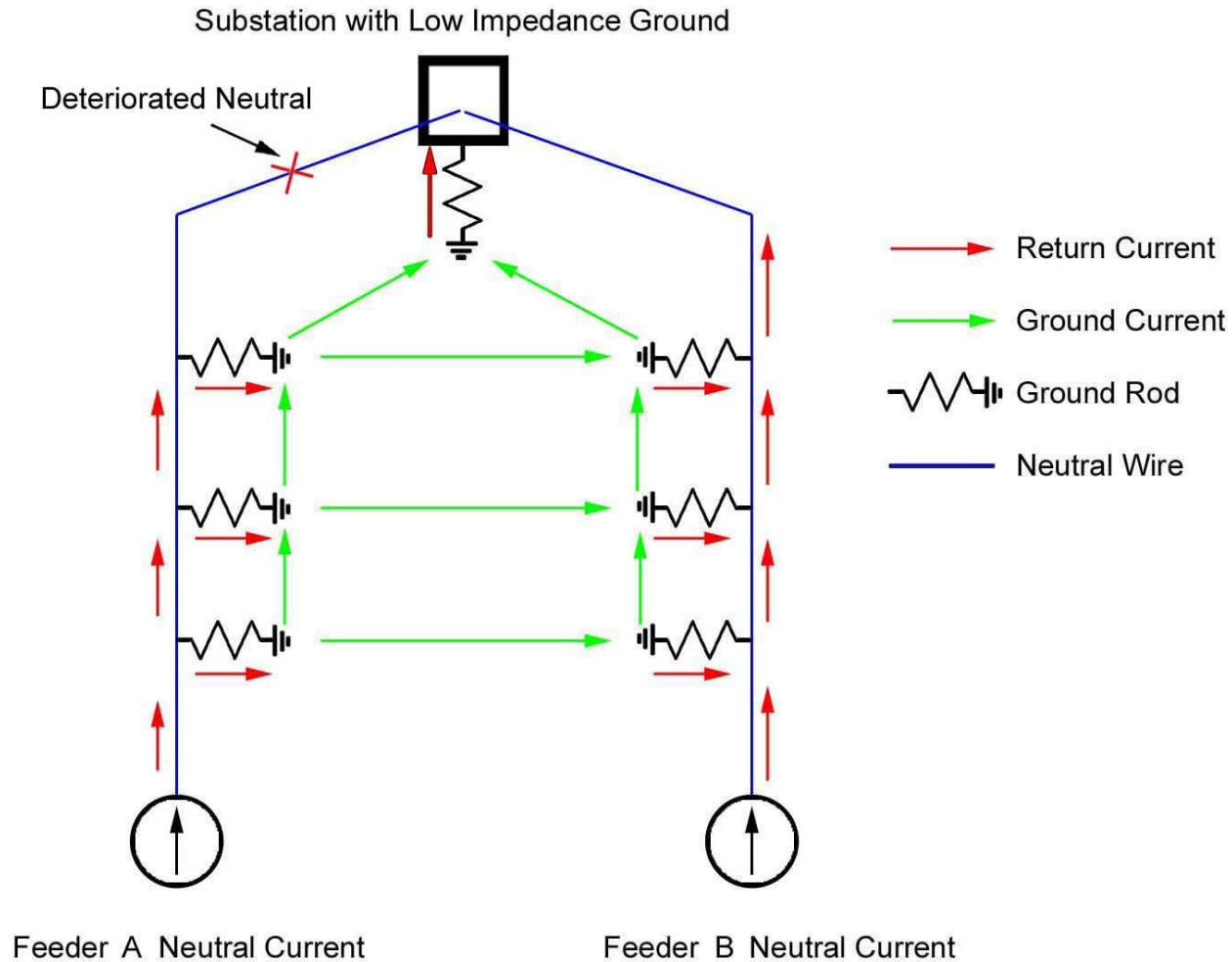

# Complexity of Analysis

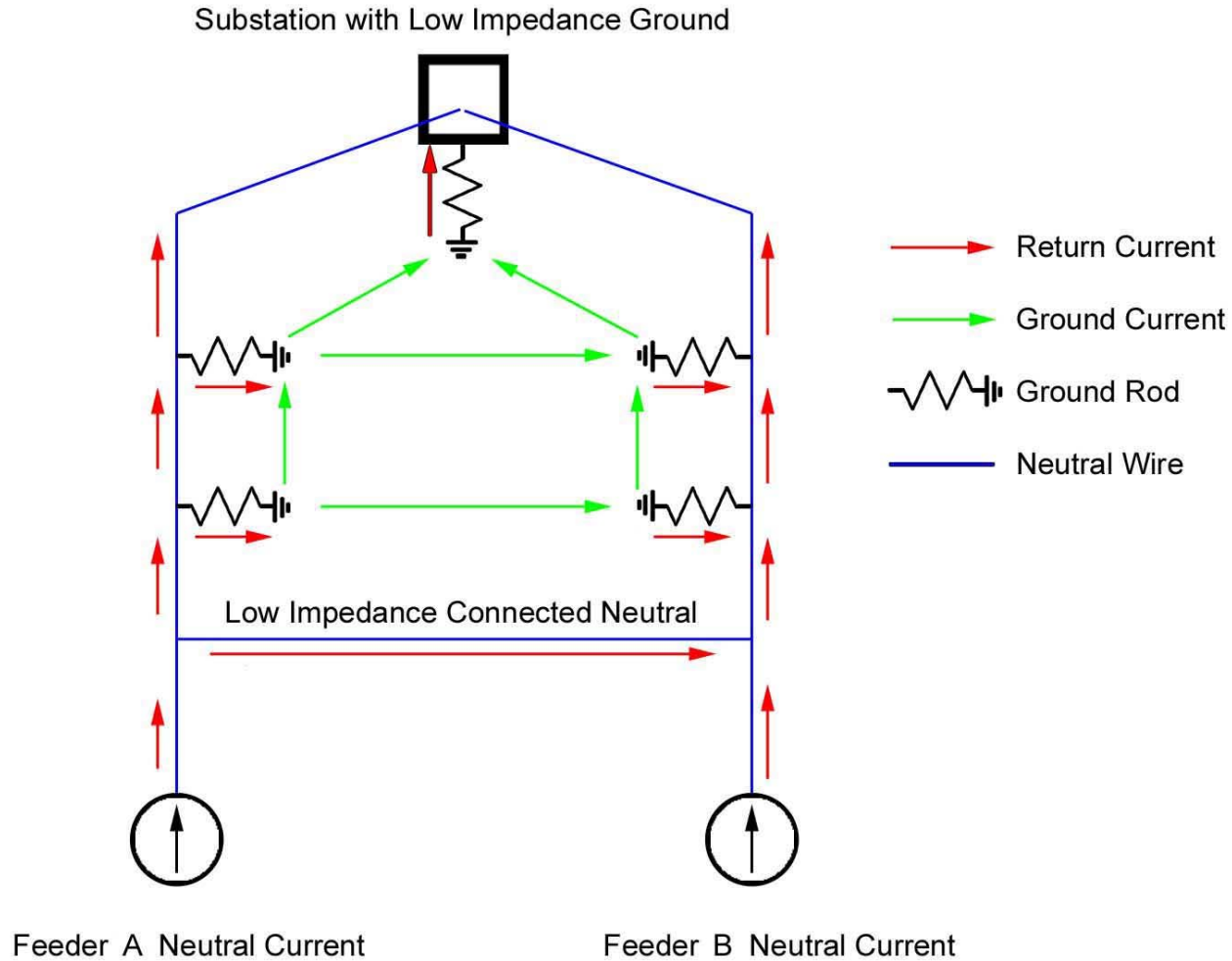

# Conclusions:

- **Terminology is not well defined**
- **Detection of contributing source is difficult**
- **Analysis is complicated**
- **Mitigation is not simple**