

Agenda: Off Circuit Tapchangers

- Introductions
- Membership
- Old Minutes
- **Mission-Develop Functional Life Test and Report for De-energized Tap-changers**
- **Reports from Rienhausen, Central Moloney, Quality Switch/Cooper, and others on test results**
- Documents
 - Existing C57.131 Requirements for Load Tapchangers
 - Draft Document IEC 60214
 - P.J.H. Proposed Life Test**
 - PJH Proposed Report**
- Discussion
- Future Work
- Adjourn

Agenda: Off Circuit Tapchangers

Meeting Minutes from Minneapolis, MN October, 2007

Hilton Minneapolis Hotel, Minneapolis, Minnesota – October 16, 2007

Chairman: Phil Hopkinson

Secretary: Scott Choinski

The Task Force on Life Tests, De-energized Tap Changers was called to order at 9:30 AM on October 16, 2007. There were 33 attendees, 13 members, and 20 guests with 2 requesting membership. Reviewed the agenda for the meeting, and the Minutes from the March 13, 2007, meeting in Dallas, Texas, were approved.

1. Mission – Develop Functional Life Test and Supporting Technical Paper for De-energized Tap-changers. Reminder that the goal is to develop the test and have a paper that supports the test. Test will ultimately be included in C57.131.
2. Mr. Hopkinson reviewed slides from the agenda posted on the Transformer Committee Website.
 - a. Life considerations
 - b. Tapchanger Suitability for Synthetic Insulating Liquids
 - c. Functional Life Tests Functional Life Tests-Issues
 - d. Functional Life Tests-Connections
 - e. Functional Life Tests-Issue of Oil Volume
 - I. Large liquid volume important for test validity – modified slide Large liquid volume should speed up thermal runaway
 - II. 130 C Liquid Temperature a good selection – there is a safety concern with this temperature.

Agenda: Off Circuit Tapchangers

Meeting Minutes continued -2-

3. Review Test data provided by Larry Dix, Quality Switch

Silver-plated contacts and natural ester oil were used. The data looks stable.

The volume of oil should be large and should not be changed. A thought is that there is a chemical reaction is going on with the contacts and too little oil depletes this chemical. Mr. Dix estimates using 10-15 gals in testing. Mr. Kraemer estimated using 500-600 liters in testing conducted at Reinhausen.

Mr. Alan Johnson will look at defining the volume of oil to use in testing.

Natural ester oil – very stable

Mineral oil – moderate stability

Silicone – very unstable

Members are to consider other combinations of where to attach leads and thermal parameters.
Additional testing to be conducted by Mr. Dix and Mr. Kraemer.

4. New Business

There was no new business.

The meeting adjourned at 10:45 AM.

Working Group for Off-Circuit Tapchangers **by Philip J. Hopkinson**

Mission:

Develop Functional Life Test and Report for De-energized tapchangers that recognizes transformer applications

Reference Documents:

C57.12.00 - General Requirements for Liquid Filled Transformers

C57.12.01 - General Requirements for Dry-Type Transformers

C57.91 - Guide for Loading Mineral Oil Immerse Transformers

C57.96 - Guide for Loading Dry-Type Distribution and Power Transformers

General requirements for Off-Circuit Tapchangers

Off-circuit tap-changers specified in this standard are for use with liquid filled and air insulated transformers and shall only be operated with the transformer de-energized.**

Since these tap-changers are always used as integral parts of transformers, the current ratings must coordinate with the expectations on the transformer. Transformer loading guides allow up to 2 times rated current for up to ½ hr. daily, dependent on ambient temperature and loss of life considerations. This is consistent with Section 9.2.1 of IEEE Loading Guide C57.91-1995. In addition, cold-load pickup of up to 3 times load is permissible as well as inrush current.

The thermal environment for off-circuit tap-changers is normally in or near the top-oil for liquid-filled transformers. Hence the tap-changer must be designed to operate satisfactorily in this environment. For liquid-filled transformers, the sustained rated liquid temperature shall be assumed to be as follows:

$$T_{oil} = T_{tor} + T_{amb}$$

Where

- T_{oil} is the oil temperature for the tap-changer
- T_{tor} is the top oil rise of the transformer
 - The rated rise occurs at rated steady-state load
 - The maximum rise occurs at the highest allowable overload
- T_{amb} is the outside ambient for the transformer

Insulation System	T _{tor}		T _{amb}		T _{oil}	
	Rated	Max	Rated	Max	Rated	Max
55 C	45	60	20	40	65	100
65 C	55	70	20	40	75	110

Charlotte, NC March 18, 2008
Note that the 110 Max oil temperature is consistent with Section 9.2.1 of IEEE Loading Guide C57.91-1995

Dry Type Tap-changers

Dry type tap-changers can be considered to be of three different styles:

- a. Suitable for mounting above the core-clamp and exposed to air that is heated by the transformer windings
- b. Suitable for mounting within the transformer cabinet but not above the transformer core and windings
- c. Suitable only for mounting in a separate enclosure and not exposed to air that is heated by the windings or core.

Tap-changer air temperatures for the three cases are as follows:

Style	Outside Amb		Rise/Amb		Net Air Temp	
	Rated	Max	Rated	Max	Rated	Rise
a. On Core Clamp	30	40	130	150	160	190
b. In trans. Cabinet	30	40	50	70	80	110
c. Separate Cabinet	30	40	20	30	50	70

Life Considerations

Life expectancy is commonly addressed in terms of thermal life. Transformer thermal life is assumed to be 20 years. In IEEE's Liquid-filled transformer loading guide (IEEE 57.91-1995), uses 180000 hours at rated load and ambient as the thermal index. Thermal life is a parameter that is both dependent on temperature and material composition. Both insulation and contact deterioration by oxydation have been found to obey the 10°C rule. Under the rule, each 10°C above or below the reference temperature causes life to change by 2 to 1.

Nameplate/Specified Ratings

Tap-changers shall be rated in terms of the following criteria and other requirements irrespective of the type of construction:

Table 5A-Rated current characteristics of off-circuit tap-changers

Maximum Continuous Rated Current Amps	Maximum Double Current for 1/2 hr. /Day	Max Symmetric Through-fault Current (amps)	Max Crest Fault Current (amps)
--	---	--	--------------------------------------

Table 5B-Rated voltage characteristics of off-circuit tap-changers

System Highest Voltage	BIL Line- Gnd	Max BIL Tap-Tap	Max BIL Between 2 Tap Positions
------------------------------	---------------------	--------------------	---------------------------------------

Quality Switch Silver-Silver Rotating Contact Tapchanger Ratings New IEC/IEEE Format

Switch No.	Voltages, (000)				Current Ratings, Amps			
	Highest System Volts	Max. System BIL	Max. BIL Tap-Tap	Max. BIL Tap-2 Taps	Max. Continuous	Max. 2x Rated ½ hr./day	Max. Symm Thru-Fault Current	Max. Crest Fault Current
Single Ring								
70-543-01	25	125	150	132	200	400	5000	7500
70-543-02	35	200	150	132	200	400	5000	7500
70-543-04	45	250	150	132	200	400	5000	7500
Triple Ring								
70-545-02	35	150	150	132	500	1000	14,000	20,000

New ratings allow users to match transformer application

Tapchanger Suitability for Synthetic Insulating Liquids

Synthetic insulating liquids may behave quite differently than mineral oil. Some of the more pronounced differences that have been observed are oxidation-stability, lubricity, heat transfer, dielectric integrity, flammability, and viscosity. Tap-changer ratings for use in synthetic insulating fluids must be established by the manufacturer.

Stability in Natural Ester Fluid

Natural ester fluid has proven to be stable in testing to date for a wide variety on contact pairs. It is still recommended that manufacturers test any proposed combinations of fluids and contact pairs to develop stability considerations before establishing switch ratings.

Routine and Type Test Requirements

Test	Routine	Type
a. Contact Resistance	X	
b. Contact spring pressure	X	
c. Dielectric Integrity	X	
d. Functional Life		X
e. Short Circuit		X
f. Mechanical endurance		X
g. Operating torque (manual)		X
h. Gland seal (Vacuum)	X	

Temperature Rise of Contacts

Tests shall be performed to verify that the temperature rise above the medium surrounding each type of contact, which carries current continuously in service, does not exceed the values given in table 6. This test shall be performed when the contacts have reached a steady temperature when carrying the through-currents in accordance with table 6, with tap-changer ambient in accordance with the rated values in section 7.1. The test is performed by measurements with thermocouples or other devices capable of measuring bulk temperature, and ambient liquid or air. The bulk rise is the difference between the bulk temperature and the temperature of the tap-changer environment (liquid or air).

It is important to note that the temperature rises in table 6 are limit values. The manufacturer must recognize that stable materials must be used so that aging does not result in thermal runaway. Time shall not result in higher temperature rises at the table 6 currents.

Table 6- Contact temperature-rise for off-circuit tap-changers

Style	Rated Current	2X Rated Current
Liquid	10	30
Dry	25	75

Functional Life Tests

A functional life test shall be performed as a Type Test to demonstrate the adequacy of the contact design to achieve long stable thermal life. The test consists of thermal cycling at accelerated current and temperature, with daily cool-down cycles. A successful test is completed if contact resistance remains within 25% of the original value and stability is achieved.

The test is conducted by passing twice rated current through the contacts for 8 hours per cycle at ambient temperatures of 130°C

A total of 30 cycles (days) of the 8-hour on 16 hour off 2XN current are required to complete the functional life test.

2 Criteria of success:

1. Resistance change <25%
2. Stability reached

Functional Life Tests-Issues

Issues for test

1. Connections to tapchanger for current, voltage and temperature
2. Oil volume for the test
3. Oil temperature
4. Current in multiples of rating

2 Criteria of success:

1. Resistance change <25%
2. Stability reached

Functional Life Tests-Connections

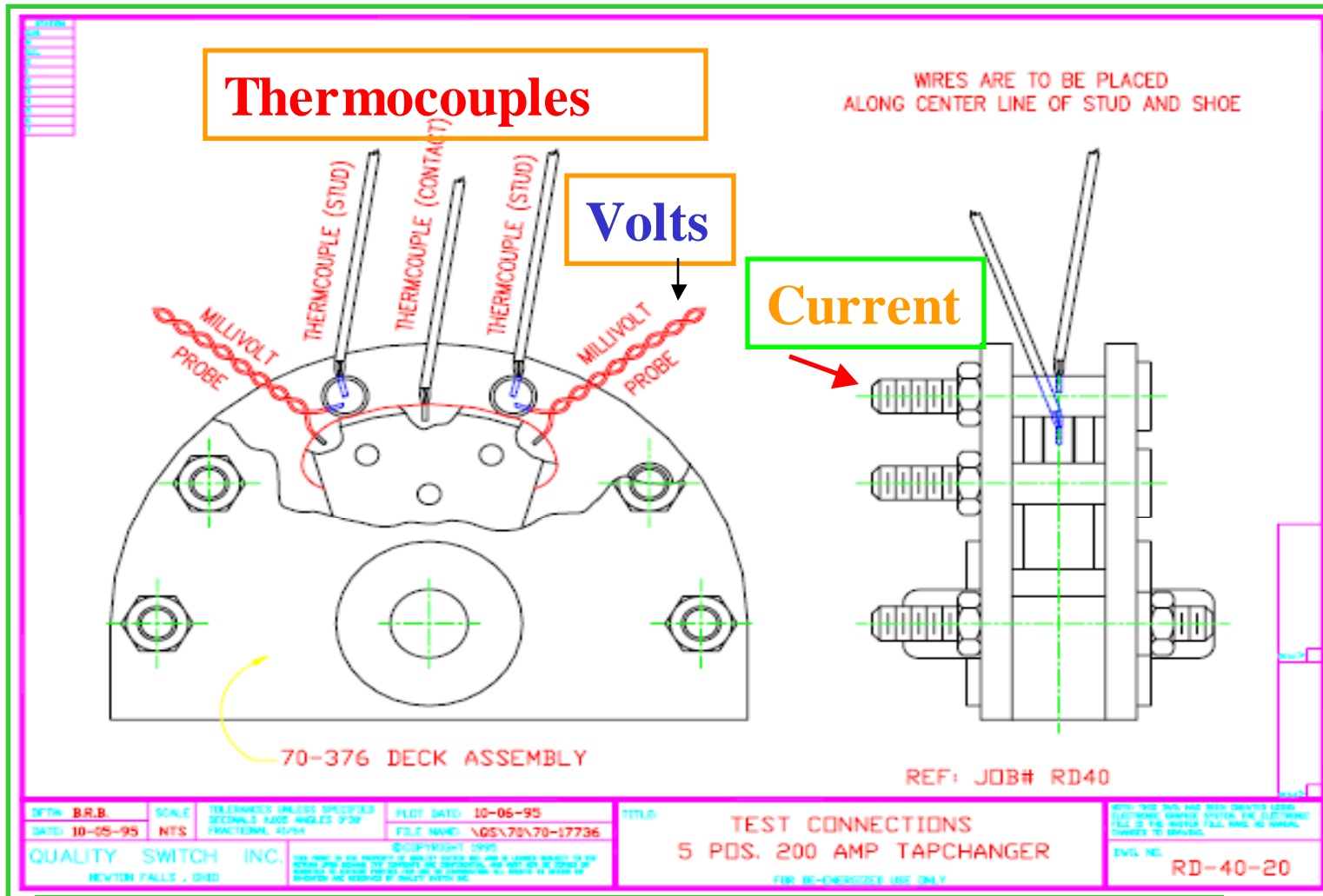

Tapchanger thermocouple and voltage measurements, courtesy of Quality Switch

Functional Life Tests-Multiple decks in series

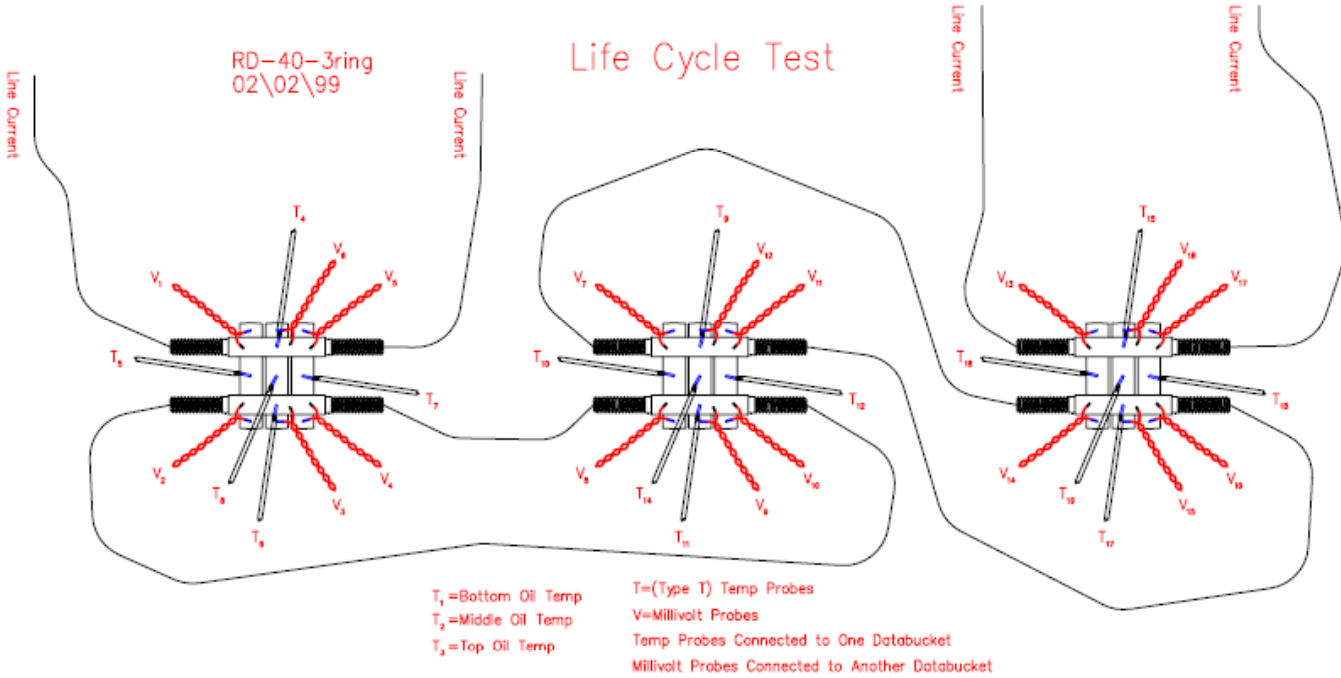

**Hi gh Current Tapchanger (>500 amp rated)
Connections, courtesy of Quality Switch**

Functional Life Tests-Issue of Oil Volume

Large liquid volume important for test validity

1. Most representative of real transformer environment
2. Will contain dissolved gases
3. Provides opportunity for replacement of oxidized liquid
4. Should slow down thermal runaway

Important to replicate real environment

Functional Life Tests-Issue of Oil Volume

130 C Liquid Temperature a good selection

1. Possible in real transformer at 2XN load for 1/2 hour in 30-40 C ambient.
2. Reflects IEEE C57.91 Loading Guide
3. Provides representative viscosity and activity
4. Provides sufficient acceleration to be reproducible

Important to replicate real environment

Functional Life Tests-Issue of Oil Volume

2XN current important to test

1. Possible in real transformer at 2XN load for ½ hour in 30-40 C ambient.
2. Reflects IEEE C57.91 Loading Guide
3. Provides representative heating and current density.
4. Contact super temperatures respond:
 - Low rise for stable contacts
 - Thermal runaway with oxidation

Important to replicate real environment

TABLE 1 Electrical Contact Super Temperature									
	Super Temp =	$\text{SQRT}((T_a+T_o+T_b+273)^2 + (A^3 \cdot 0.001)^2) / (4 \cdot 2.4 \cdot 10^{-8}) - 273$							
	Ta = Ambient	20		20		20		20	
	To = Oil Rise	50		110		110		110	
	Tb = Bulk Rise	20		40		60		20	
	Bulk Temp	90		170		190		150	
Millivolts	Super Rise	Super Temp	Super Rise	Super Temp	Super Rise	Super Temp	Super Rise	Super Temp	Condition
10	1.4	91.4	1.2	171.2	1.1	191.1	1.2	151.2	Good
20	5.7	95.7	4.7	174.7	4.5	194.5	4.9	154.9	
30	12.7	102.7	10.5	180.5	10.0	200.0	10.9	160.9	
40	22.3	112.3	18.4	188.4	17.7	207.7	19.3	169.3	Marginal
50	34.3	124.3	28.5	198.5	27.3	217.3	29.7	179.7	
60	48.4	138.4	40.5	210.5	38.9	228.9	42.2	192.2	
70	64.6	154.6	54.3	224.3	52.2	242.2	56.6	206.6	Unstable
80	82.5	172.5	69.8	239.8	67.1	257.1	72.6	222.6	
90	101.9	191.9	86.7	256.7	83.6	273.6	90.1	240.1	
100	122.7	212.7	105.1	275.1	101.4	291.4	109.1	259.1	Thermal Run-A-Way
110	144.8	234.8	124.7	294.7	120.4	310.4	129.2	279.2	
120	167.8	257.8	145.4	315.4	140.6	330.6	150.5	300.5	
130	191.8	281.8	167.2	337.2	161.8	351.8	172.8	322.8	
140	216.6	306.6	189.8	359.8	183.9	373.9	195.9	345.9	
150	242.1	332.1	213.2	383.2	206.9	396.9	219.9	369.9	
160	268.2	358.2	237.4	407.4	230.6	420.6	244.5	394.5	
170	294.9	384.9	262.2	432.2	254.9	444.9	269.8	419.8	
180	322.0	412.0	287.6	457.6	279.9	469.9	295.6	445.6	
190	349.6	439.6	313.5	483.5	305.4	495.4	322.0	472.0	
200	377.6	467.6	339.9	509.9	331.4	521.4	348.7	498.7	

Results of Life Tests

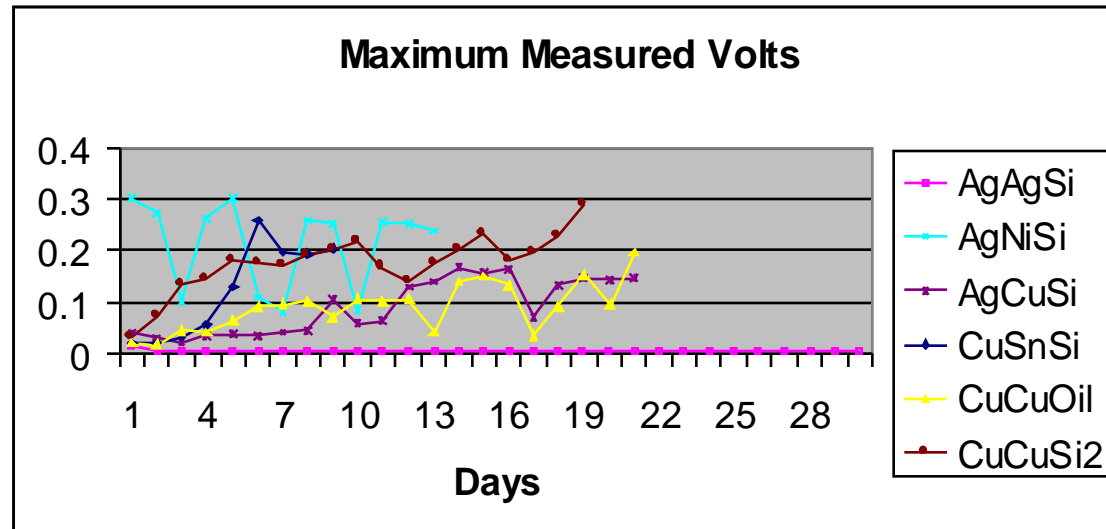
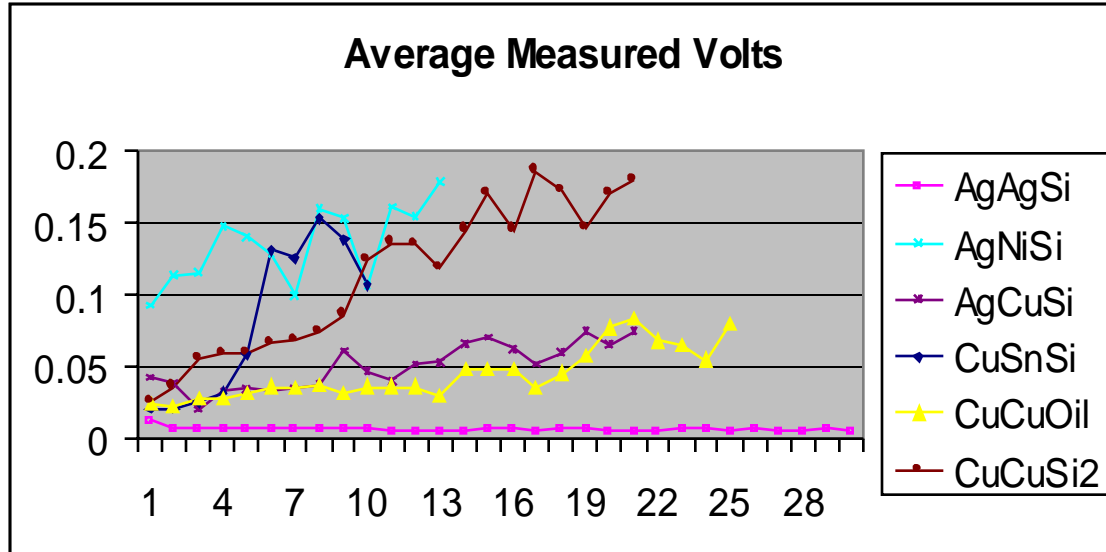

Voltage is measured between the two mating contacts under test.

Charlotte, NC March 18, 2008

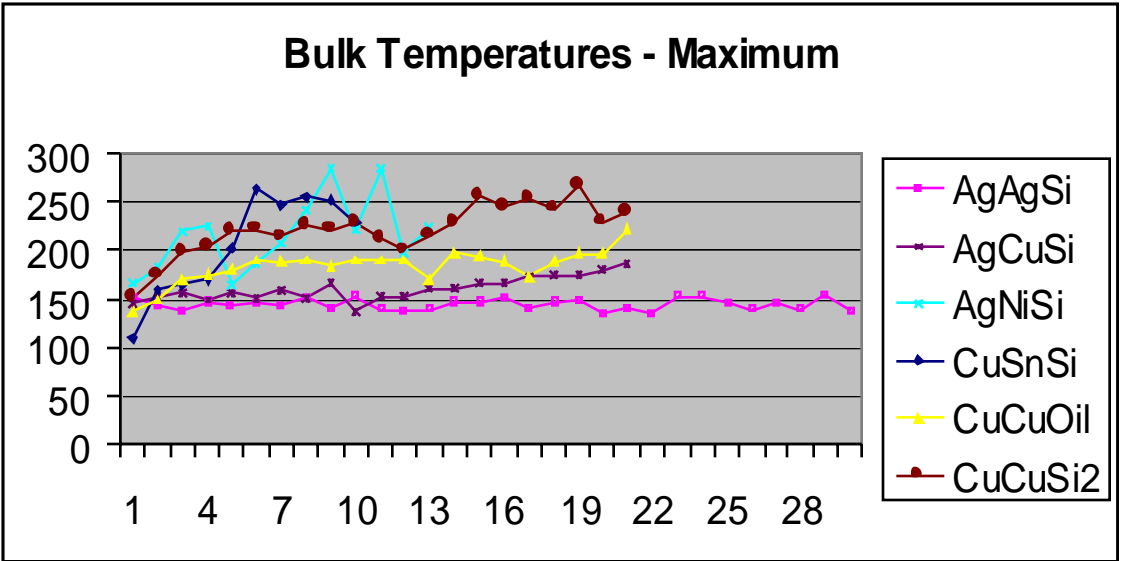
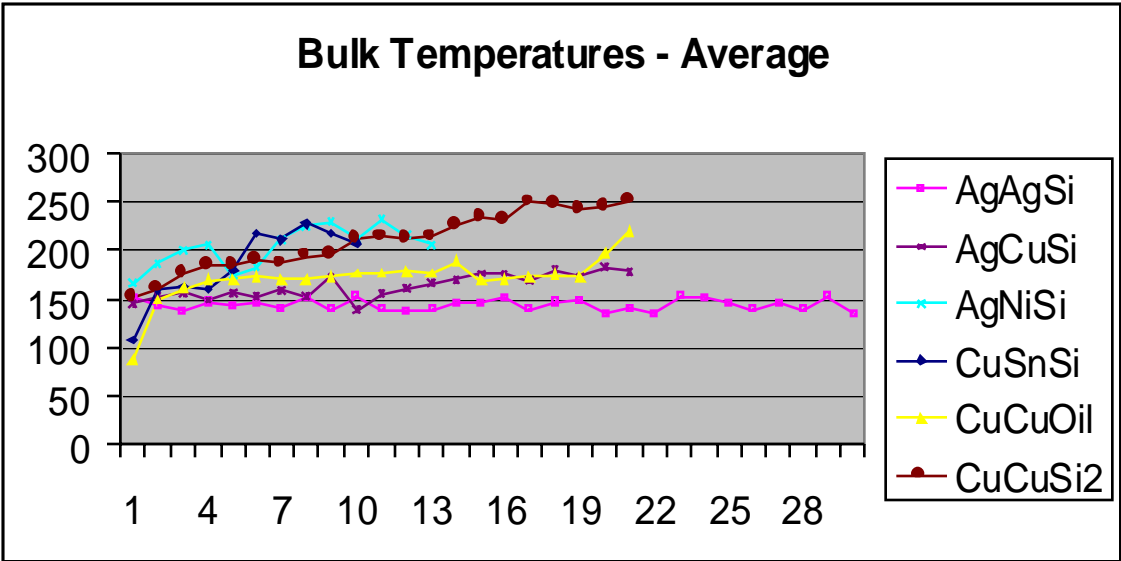

Bulk temperature in degrees C is the average temperature of the two mating contacts under test measured by thermocouple

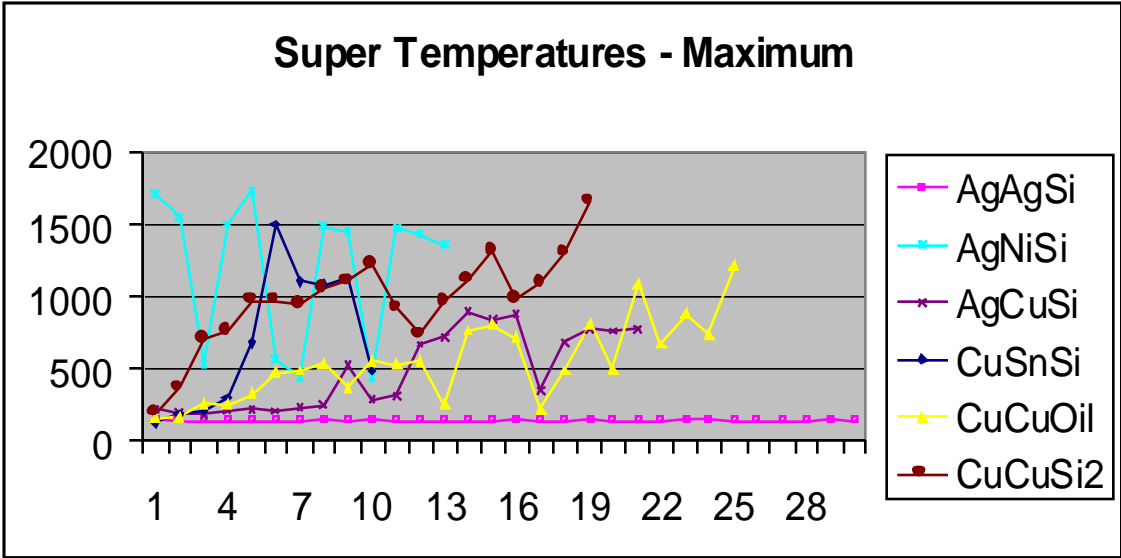
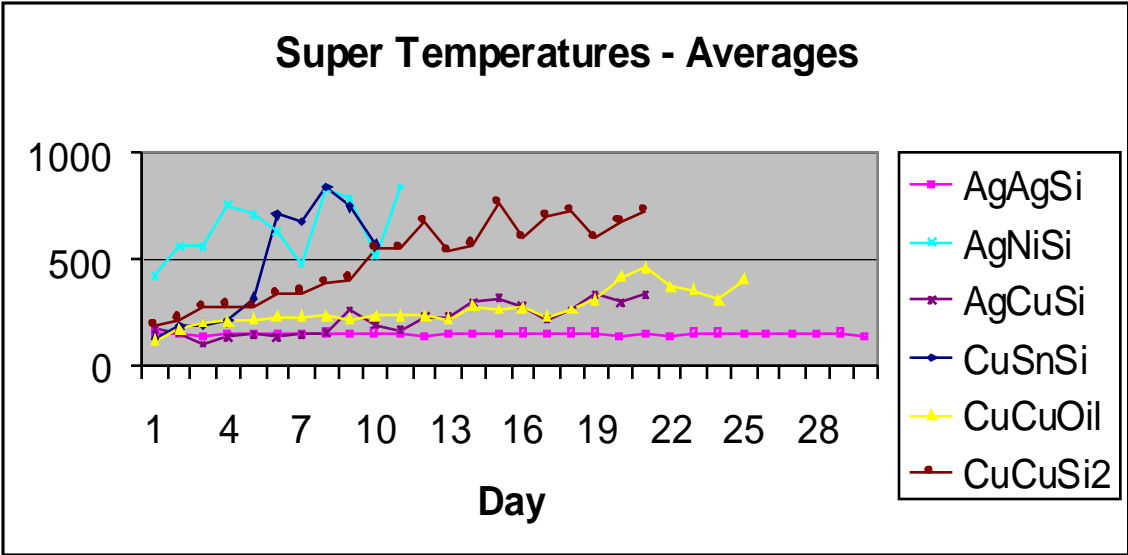

Super temperature is a calculated parameter in degrees C and refers to the temperature of the point of contact of the two mating contacts under test

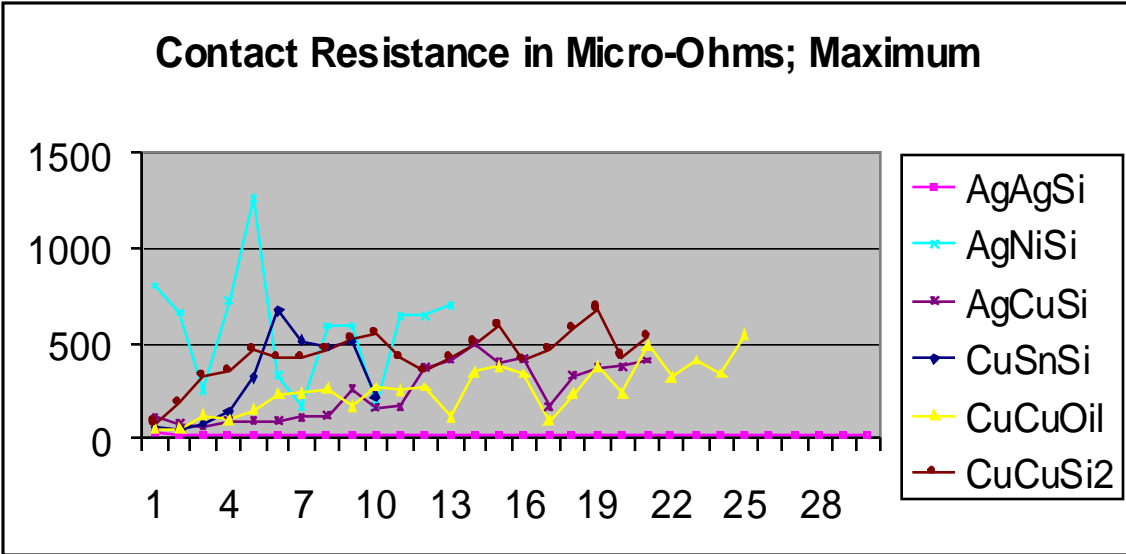
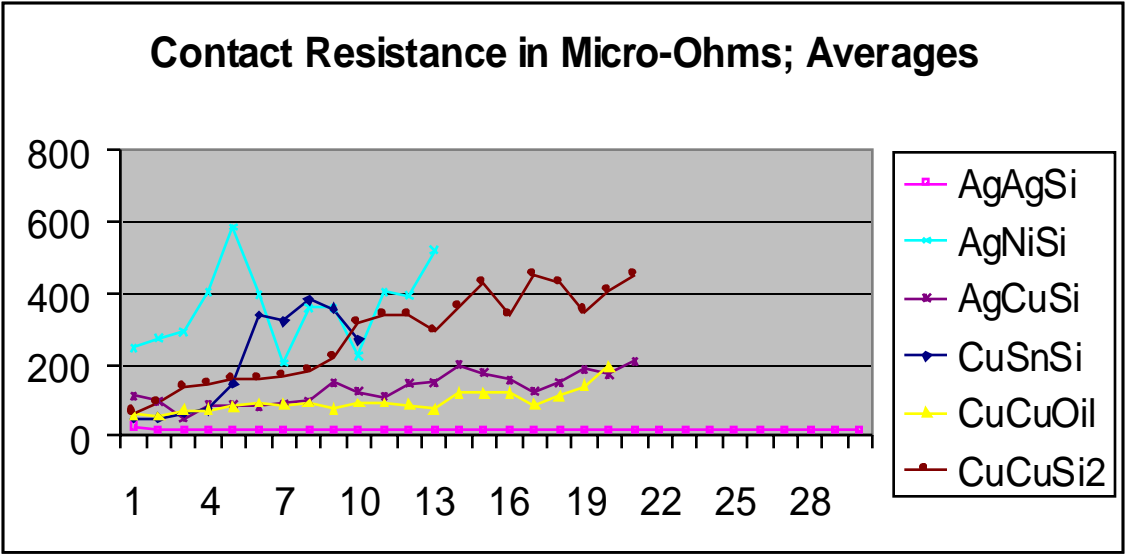

Contact resistance is measured by dividing the contact voltage under test by the test current

Assessment Time De-energized Tapchangers

New Work at Quality Switch

- Contacts: Tin plated copper versus plain copper
- FR3 Natural Ester Fluid
- 30 day test
- Status report after 16 days on test

Similar tapchangers in silicone and mineral oil unstable at first day on test.

Assessment Time De-energized Tapchangers

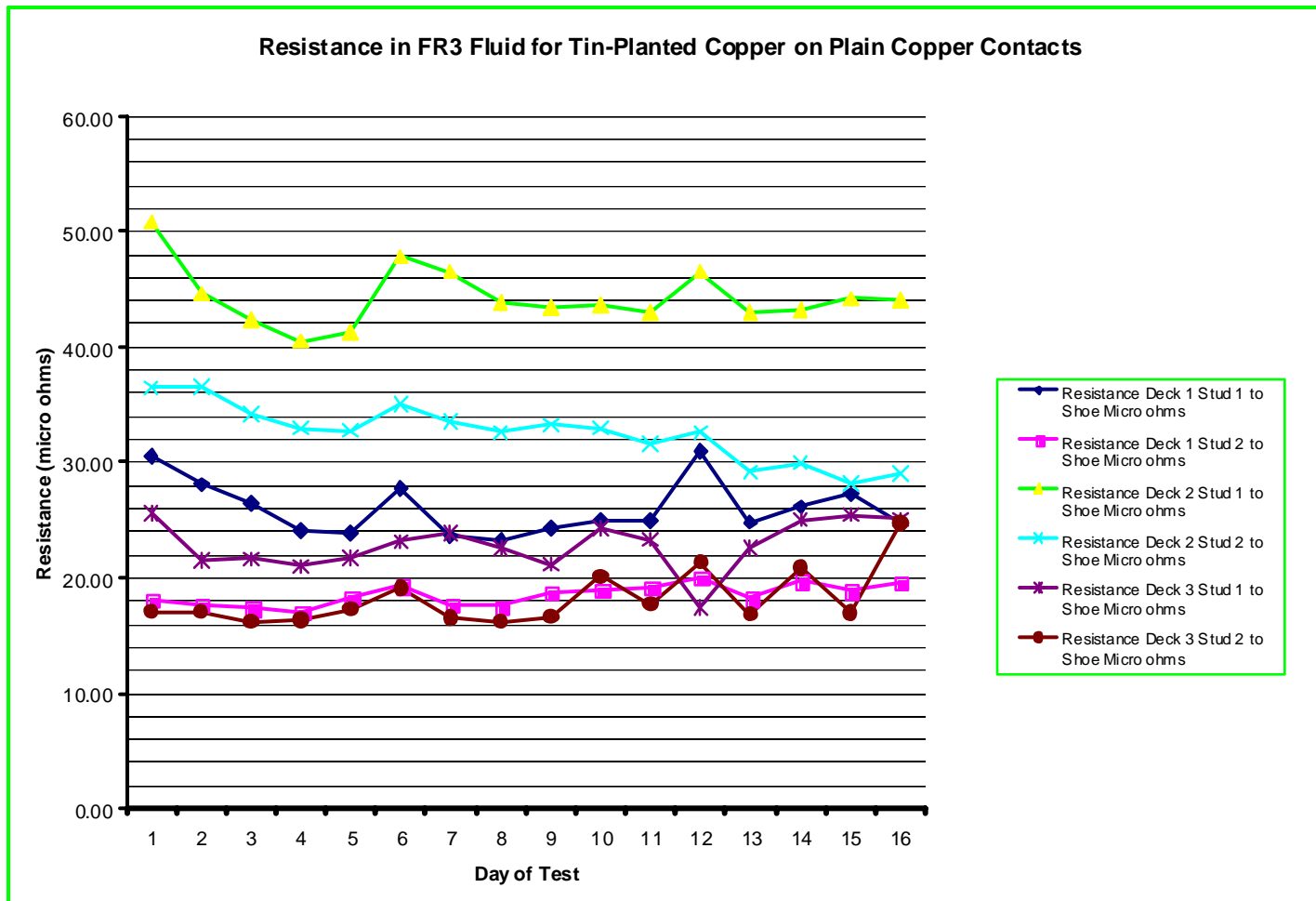

Similar tapchangers in silicone and mineral oil unstable at first day on test.

Assessment Time De-energized Tapchangers

Completed Work

- Functional Life Test Defined
- (3) Manufacturers have performed test
- **Test correlates with Harsh Duty field experience-switches that pass do well.** Example transformers – rolling mills

Limitation: General Purpose Transformers with light duty work OK with unstable contacts

Assessment Time De-energized Tapchangers

Completed Work-2

- Draft Technical Report issued

Limitation: To date: Only one author on paper

Assessment Time De-energized Tapchangers

Remaining Work

- Modified tests for other currents and bath temperatures
- Unified definition of the Functional Life Test
- Agree on Technical Paper
- Transmit materials for inclusion in C57.131

Assessment Time De-energized Tapchangers

Recommendations

- Stop data Quest in 1 more meeting at **Spring 2008**
- Freeze test at present definition
Completed now
- Agree on Technical Paper **Fall 2008**
- Transmit materials for inclusion in C57.131
Spring 2009