

HARMAN

AVTP Video Format

Dave Olsen

10/10/2011

AKG

harman/kardon

 Infinity

 JBL

lexicon

mark
Levinson

We are proud of our 60 years of innovation, technical excellence and multiple GRAMMY® Awards.

GRAMMY is a registered trademark of The Recording Academy.

Simple Video Format

- **Single timestamp**

- Timestamp always references the first sample in the packet
- Timestamp will represent a presentation time

- **Support for some MIME video types**

- MJPEG
 - RFC 2435 (Can we reference an RFC???)
- Raw Sensor Video Data
 - Bayer
- I-frame only MPEG
 - H.264 I frame only formats (AVC Intra 50, 100)

Packet Format

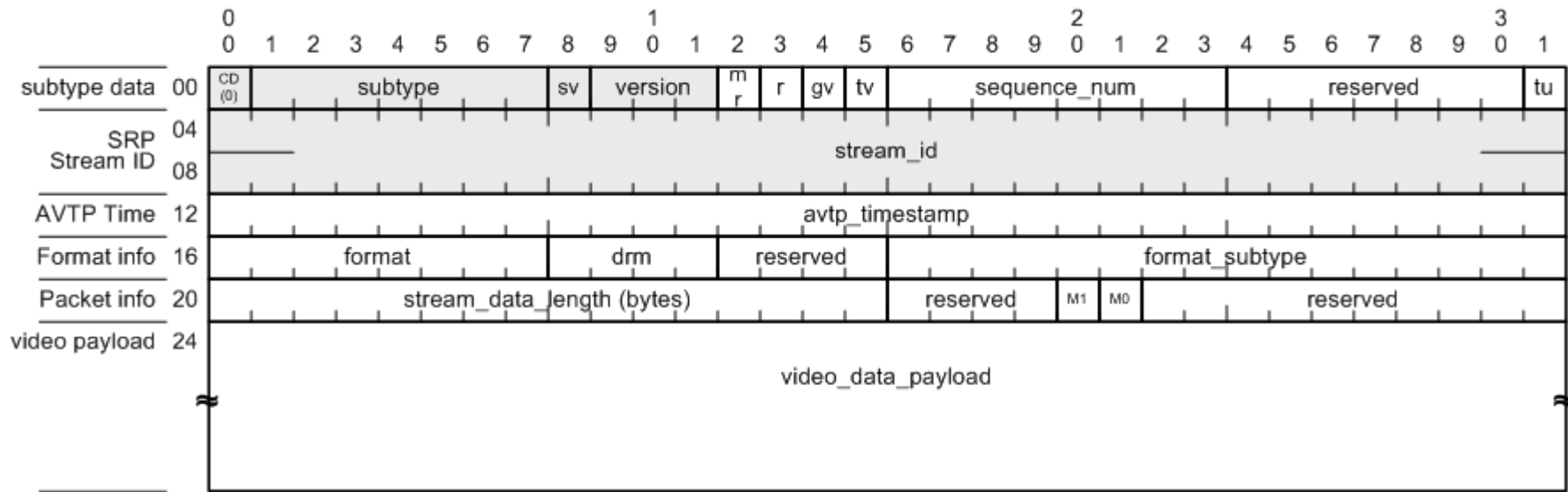

Format/Subtype

- **0x01 – AVTP format**
 - 0x01 RAW sensor video format (Bayer)
- **0x02 – MIME**
 - 0x01 MJPEG
- **0x254 – Vendor Specific**
- **0x255 – Experimental**

RAW sensor video data header

- **Resolution**

- Vertical (16 bits)
- Horizontal (16 bits)
- Depth 8,10,12 (8 bits)

- **Mosaic Pattern (8 bits)**

- Bayer-RGB, Bayer-CYM, RGBE, CYYM, CYGM, RGBW Bayer, ...

- **Phase (2 bits)**

- **Current Location (designates location of the first data in the packet)**

- Vertical (16 bits)
- Horizontal (16 bits)

-
- **RFC 2435**
 - **Timestamp is Presentation Time in gPTP time**
 - Similar to other 1722 formats
 - **MJPEG Header (from RFC 2435)**
 - Type-specific (8 bits)
 - Fragment Offset (24 bits)
 - Type (8 bits)
 - Q (8 bits)
 - Width (8 bits)
 - Height (8 bits)

I Frame only MPEG

▪ H.264 profiles

- High 10 Intra Profile
 - The High 10 Profile constrained to all-Intra use.
- High 4:2:2 Intra Profile
 - The High 4:2:2 Profile constrained to all-Intra use.
- High 4:4:4 Intra Profile
 - The High 4:4:4 Profile constrained to all-Intra use.
- CAVLC 4:4:4 Intra Profile
 - The High 4:4:4 Profile constrained to all-Intra use and to CAVLC entropy coding (i.e., not supporting CABAC).

I Frame only MPEG

- **AVC-Intra 50:**

- nominally 50 Mbit/s, size of each frame is fixed
- [CABAC entropy coding](#) only.
- 1920x1080 formats are High 10 Intra Profile, Level 4
- 1280x720 formats are High 10 Intra Profile, Level 3.2
- [4:2:0](#) chrominance sampling
- frames are horizontally scaled by 3/4 (1920x1080 is scaled to 1440x1080. 1280x720 is scaled to 960x720)

- **AVC-Intra 100:**

- nominally 100 Mbit/s, size of each frame is fixed
- [CAVLC entropy coding](#) only.
- All formats are High 4:2:2 Intra Profile, Level 4.1
- [4:2:2](#) chrominance sampling
- frames are not scaled

- **Common to both classes;**

- **Frame rates: 1920x1080 (23.98p / 25p / 29.97p / 50i / 59.94i), 1280x720 (23.98p / 25p / 29.97p / 50p / 59.94p)**
- **10 bit luma and chroma**

HARMAN

WHERE SOUND MATTERS

AKG

harman/kardon

 Infinity

 JBL

lexicon

mark
levinson