

# HARMAN

## Automotive Update

Dave Olsen

**AKG**

harman/kardon

Infinity

**JBL**

**lexicon**

mark  
Levinson

We are proud of our 60 years of innovation, technical excellence and multiple GRAMMY® Awards.

GRAMMY is a registered trademark of The Recording Academy.

# Automotive Topology

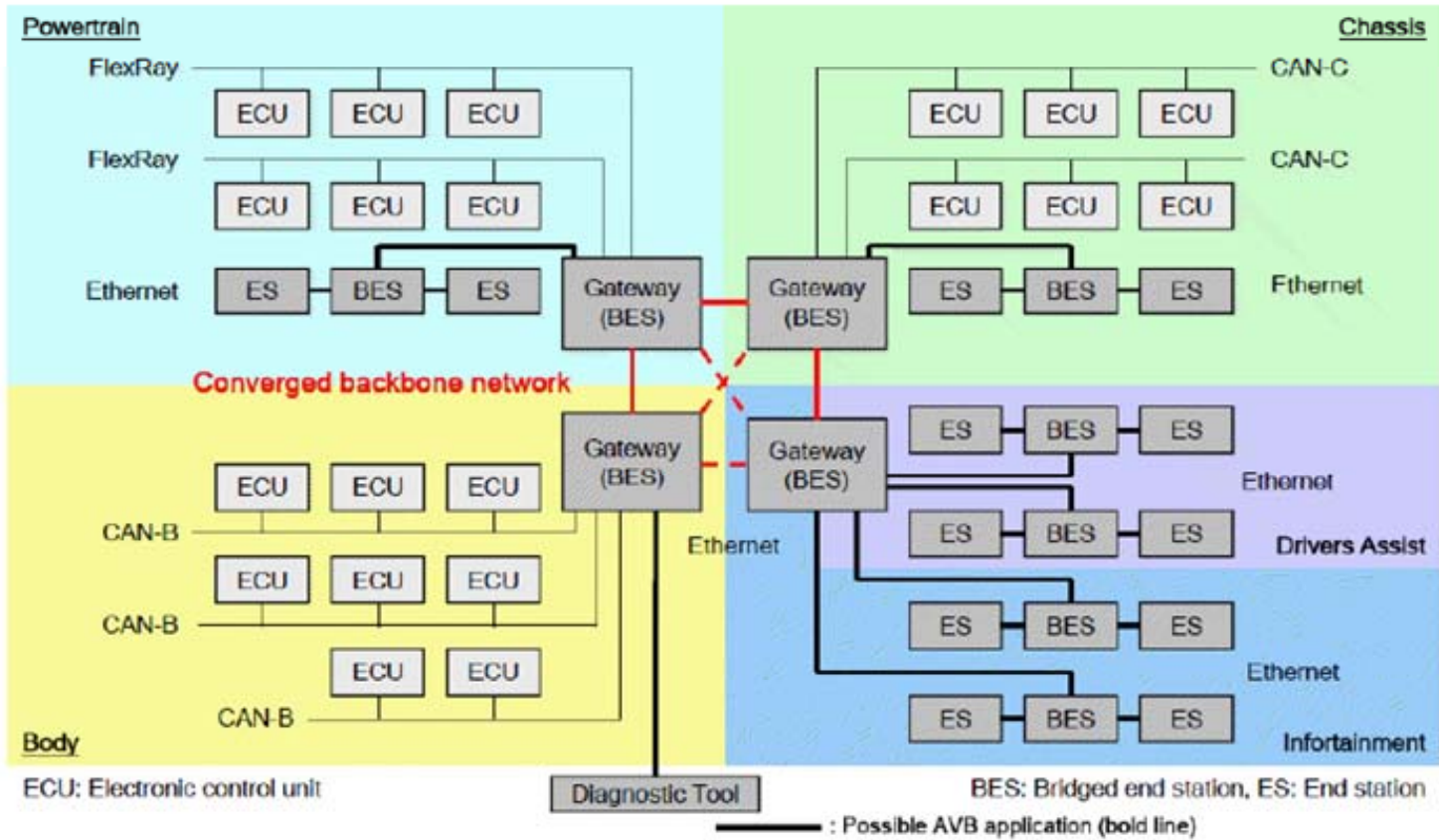

---

## ▪ Automotive Network

- Increasing demand for bandwidth
- Desire to reduce number of networking technologies
  - LIN, CAN, FlexRay, MOST
- Distributed System need synchronization
- Guaranteed QOS required
- Guaranteed Latency required
- 50-70 ECU's in a modern car

# Problems to solve

---

- **Packet Format**
- **Network Synchronization**
  - Flexray Timing
  - CAN Priorities
- **Ultra Low latency transport**
  - Multi Talker SRP
- **Network Addressing**
- **Network Startup**
- **Network Shutdown**

# Contribution Coming

---

## ▪ Upcoming 1722a Contribution

- Flexray and CAN protocol
- New subtype required
- Contribution on Sep 6<sup>th</sup> call
  - Call moved from Sep 5<sup>th</sup> due to Labor Day Holiday

# HARMAN

WHERE SOUND MATTERS

**AKG**

harman/kardon

 Infinity

 JBL

**lexicon**

mark  
levinson