

# The Transport and Impact of Synchronization in Time-Sensitive Networking

An Introduction to IEEE 802.1AS

February 24, 2022

**1**

Upon entering the webinar, all attendee lines are automatically **MUTED**. Today's presentation is a one-way broadcast.

**2**

If you are experiencing technical issues (audio or visual), use the **CHAT feature** and message the host, for help troubleshooting.

**3**

To ask **QUESTIONS** throughout the webinar, use the **Q&A feature**.

The views expressed in this presentation are those of the speakers and do not necessarily reflect those of IEEE. To the extent any products or services are mentioned in the presentation, this is for informational and illustrative purposes only and should not be considered an endorsement of those products or services.

# RECAP – TSN WEBINAR SERIES

## WATCH THE RECORDINGS



IEEE SA  
FOUNDATIONAL  
TECHNOLOGIES  
TSN Time Sensitive  
Networking Powered by IEEE 802.1

**DRIVING DIGITAL TRANSFORMATION  
THROUGH IEEE 802.1 TSN TECHNOLOGY**

IEEE TIME-SENSITIVE NETWORKING  
WEBINAR SERIES: AN INTRODUCTION  
TO IEEE 802.1

SPEAKER: GLENN PARSONS, PRINCIPAL STANDARDIZATION  
ADVISOR, 5G TRANSPORT, ERICSSON  
MODERATED BY: SRI CHANDRASEKARAN, SR DIRECTOR & PRACTICE LEAD, FOUNDATIONAL  
TECHNOLOGIES, IEEE SA  
16 Sept 2021



IEEE SA  
STANDARDS  
ASSOCIATION  
FOUNDATIONAL  
TECHNOLOGIES  
TSN Time Sensitive  
Networking Powered by IEEE 802.1

**DRIVING DIGITAL TRANSFORMATION  
THROUGH IEEE 802.1 TSN**

IEEE TIME-SENSITIVE NETWORKING  
WEBINAR SERIES: AN OVERVIEW OF  
TIME-SENSITIVE NETWORKING

SPEAKER: JÁNOS FARKAS, PRINCIPAL RESEARCHER, ERICSSON  
MODERATED BY: SRI CHANDRASEKARAN, SR DIRECTOR & PRACTICE LEAD,  
FOUNDATIONAL TECHNOLOGIES, IEEE SA  
2 December 2021



# SPEAKER – GEOFFREY GARNER

## Consultant

Geoffrey M. Garner is a consultant specializing in network synchronization and related standards development. He has consulted for Huawei Technologies since 2008, and also for Samsung, Broadcom, Marvell, Hirschmann, Siemens, and Internet Photonics. Prior to consulting, he was a Member of Technical Staff at AT&T Bell Laboratories and Distinguished Member of Technical Staff at Lucent Technologies.

He has been editor of IEEE 802.1AS since 2006 and has contributed to the development of IEEE 1588 Precision Time Protocol (PTP) and the IEC/IEEE 60802 TSN Profile for Industrial Automation. He is a member of the IEEE Registration Authority Committee (RAC), and a Senior Member of IEEE. His standardization work has included the modeling and simulation of time error performance in networks based on PTP. He received the IEEE Standards Association Medallion in 2021.

He received his S.B., S.M., and Ph.D. degrees from M.I.T.



## SPEAKER – SILVANA RODRIGUES

---

Silvana Rodrigues, Senior Principal Engineer, Huawei

Silvana holds an Electronic and Electrical Engineering degree from University of Campinas, Brazil. She has been working on network synchronization and actively contributing to synchronization standards development for more than 15 years.

She has been the secretary of IEEE 1588 Precision Time Protocol (PTP) Working Group since the beginning of the work of IEEE 1588 version 2. She is the editor of IEEE 801.1ASdr and participates and contributes to several IEEE 802.1 TSN working groups.

She is currently the associate rapporteur and editor of several recommendations at ITU-T SG15 Q13 (the synchronization experts group).



**This presentation should be considered as the personal views of the presenters not as a formal position, explanation, or interpretation of IEEE.**

## **Per IEEE-SA Standards Board Bylaws, December 2017**

“At lectures, symposia, seminars, or educational courses, an individual presenting information on IEEE standards shall make it clear that his or her views should be considered the personal views of that individual rather than the formal position of IEEE.”

# Agenda

---

- Introduction to IEEE Std 1588 and PTP Profiles
- Introduction to IEEE Std 802.1AS
- New Features of IEEE Std 802.1AS-2020
- New work items for IEEE Std 802.1AS
- IEC/IEEE 60802 TSN Profile for Industrial Automation
- IEEE P802.1DG TSN Profile for Automotive
- IEEE P802.1DP / SAE AS6675 TSN Profile for Aerospace

**This presentation should be considered as the personal views of the presenters not as a formal position, explanation, or interpretation of IEEE.**

## **Per IEEE-SA Standards Board Bylaws, December 2017**

“At lectures, symposia, seminars, or educational courses, an individual presenting information on IEEE standards shall make it clear that his or her views should be considered the personal views of that individual rather than the formal position of IEEE.”



# Introduction to IEEE Std 1588 and PTP Profiles

---

# Introduction to IEEE Std 1588 and PTP Profiles – 1

- IEEE Std 1588 is a standard for transfer of precise time over a network using two-way exchange of timestamped messages
  - Also referred to as Precision Time Protocol (PTP)
  - The protocol includes a mechanism for choosing the best clock in the network, which the other clocks will synchronize to, and the hierarchy of the clocks (i.e., the Synchronization Spanning Tree, over which time synchronization is transferred)
    - The mechanism is the Best Master Clock Algorithm (BMCA)
- Original focus of IEEE 1588 (2002 edition) was on small local area networks used in test and measurement applications
- IEEE 1588 was subsequently generalized for the 2008 edition, for use with additional application areas, e.g., telecom, audio/video, industrial automation, power generation and distribution (electric utilities), finance, etc.
- IEEE Std 1588-2019 added a number of new, optional features
  - Fully backward compatible with 2008 edition if new optional features are not used

# Introduction to IEEE Std 1588 and PTP Profiles – 2

- IEEE Std 1588 has many optional features, and its use can require many choices, for example
  - Which of two modes to use for measurement of delay between two adjacent clocks
  - Whether to use the BMCA as specified in the standard, or an alternate BMCA, or to have the best clock and synchronization spanning tree chosen externally by a higher-layer entity
  - What network transport to use (e.g., Ethernet, IPv4, IPv6), and whether communication should be multicast, unicast (or to allow both)
  - What timescale to use (PTP (based on TAI), ARB (arbitrary timescale chosen by application))
  - Whether multiple timing domains are needed
- Note that IEEE Std 1588 does not include performance requirements, as these are application specific
- Any application that uses PTP actually must conform to a PTP Profile
  - “A PTP Profile is a set of required options, prohibited options, and the ranges and defaults of configurable attributes” (from 20.3.1.1 of IEEE 1588-2019)
  - IEEE 1588 specifies how an organization can create a PTP profile

# Introduction to IEEE Std 802.1AS

---

# Introduction to IEEE Std 802.1AS

- IEEE Std 802.1AS is the TSN standard for the transport of time synchronization
- IEEE Std 802.1AS includes
  - A PTP Profile
  - Performance requirements and related informative description (mainly oriented towards audio/video applications)
    - These performance requirements and information were developed for 802.1AS-2011, prior to the development of newer TSN applications (e.g., industrial, automotive)
    - Newer TSN applications will specify their own performance requirements
    - Note that performance requirements are considered to be outside a PTP Profile
  - Additional protocol features (not part of IEEE 1588)
- IEEE 802.1AS-2011 includes a profile of IEEE 1588-2008
- IEEE 802.1AS-2020 includes a profile of IEEE 1588-2019

# 802.1AS – Transport of Time Synchronization

- IEEE Std 802.1AS specifies transport over full-duplex Ethernet, IEEE 802.11, IEEE 802.3 EPON, and Coordinated Shared Network (e.g., MoCA)
- For full-duplex Ethernet transport
  - Mean link delay measurement using 1588 peer-to-peer delay mechanism
  - Measurement of frequency offset between the two endpoints of a link (neighborRateRatio), also using peer-to-peer delay messages
  - Accumulation of neighbor frequency offsets to obtain frequency offset relative to Grandmaster (source of time)
  - Computation of offset of a clock relative to Grandmaster using above measurements and timestamped Sync messages
- Transport over 802.11, 802.3 EPON, and CSN make use of native timing mechanism of those transports
  - Use of a native timing mechanism of a transport was added to IEEE 1588-2019 as an optional feature

# 802.1AS – Mean Link Delay and neighborRateRatio Measurement

Peer delay  
initiator

Peer delay  
responder

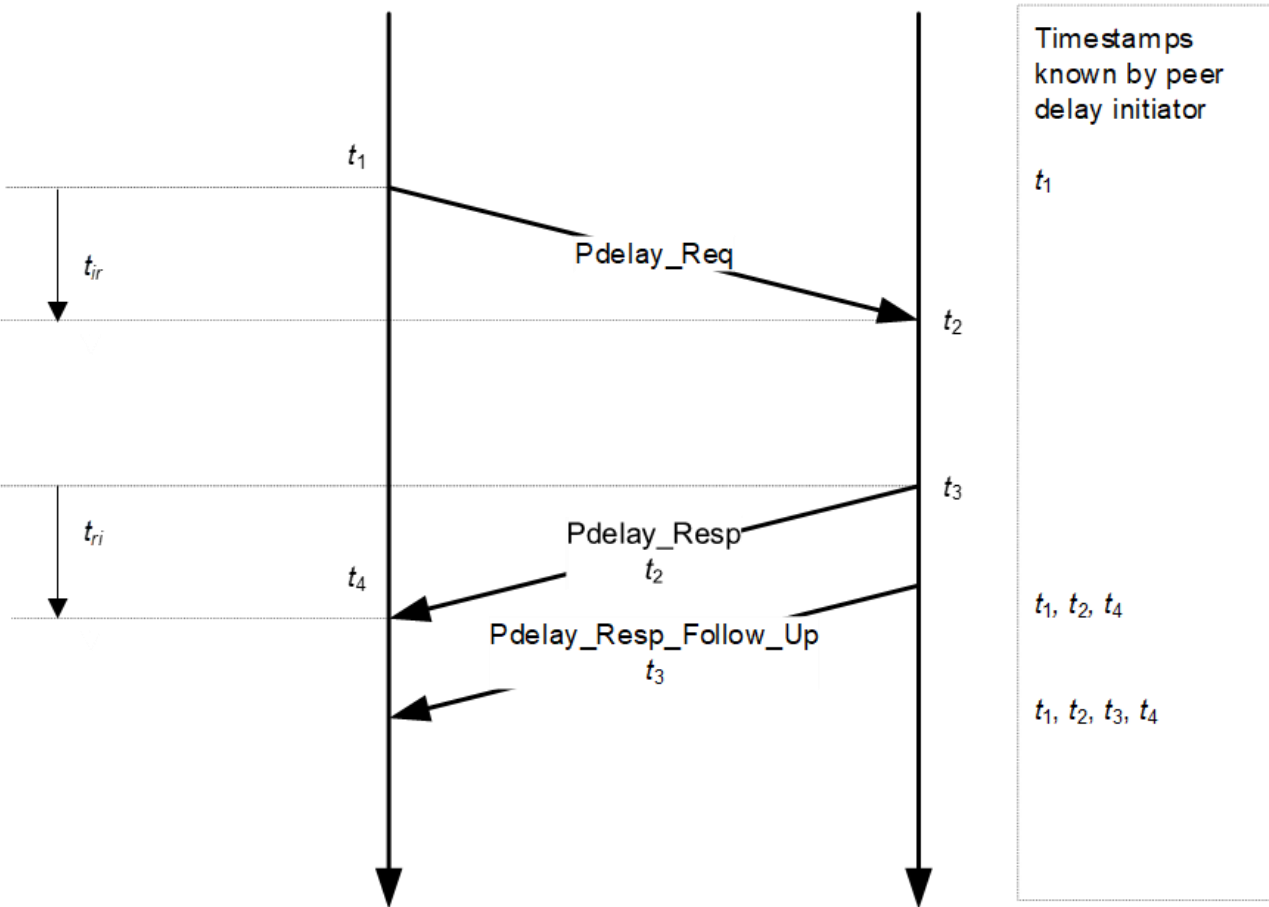

## ➤ Mean Link Delay $D$ (at peer delay initiator)

$$D = \frac{r \cdot (t_4 - t_1) - (t_3 - t_2)}{2}$$

- $D$  as computed above is relative to time base of responder
- Note, delay asymmetry must be measured externally (outside of PTP); its effect can be included via managed objects

## ➤ NeighborRateRatio ( $r$ ) (at peer delay initiator)

$$r = \frac{t_3(N) - t_3(0)}{t_4(N) - t_4(0)}$$

- $r$  is the ratio of the frequency of the peer delay initiator to the frequency of the peer delay responder
- $r$  is measured using successive `Pdelay_Resp` and `Pdelay_Resp_Follow_Up` messages to obtain the ratio of elapsed time at the responder to elapsed time at the initiator, of the same time interval
- rateRatio relative to the Grandmaster is obtained at each PTP Instance by accumulating neighborRateRatio in a TLV

# 802.1AS – Transport of Time Synchronization

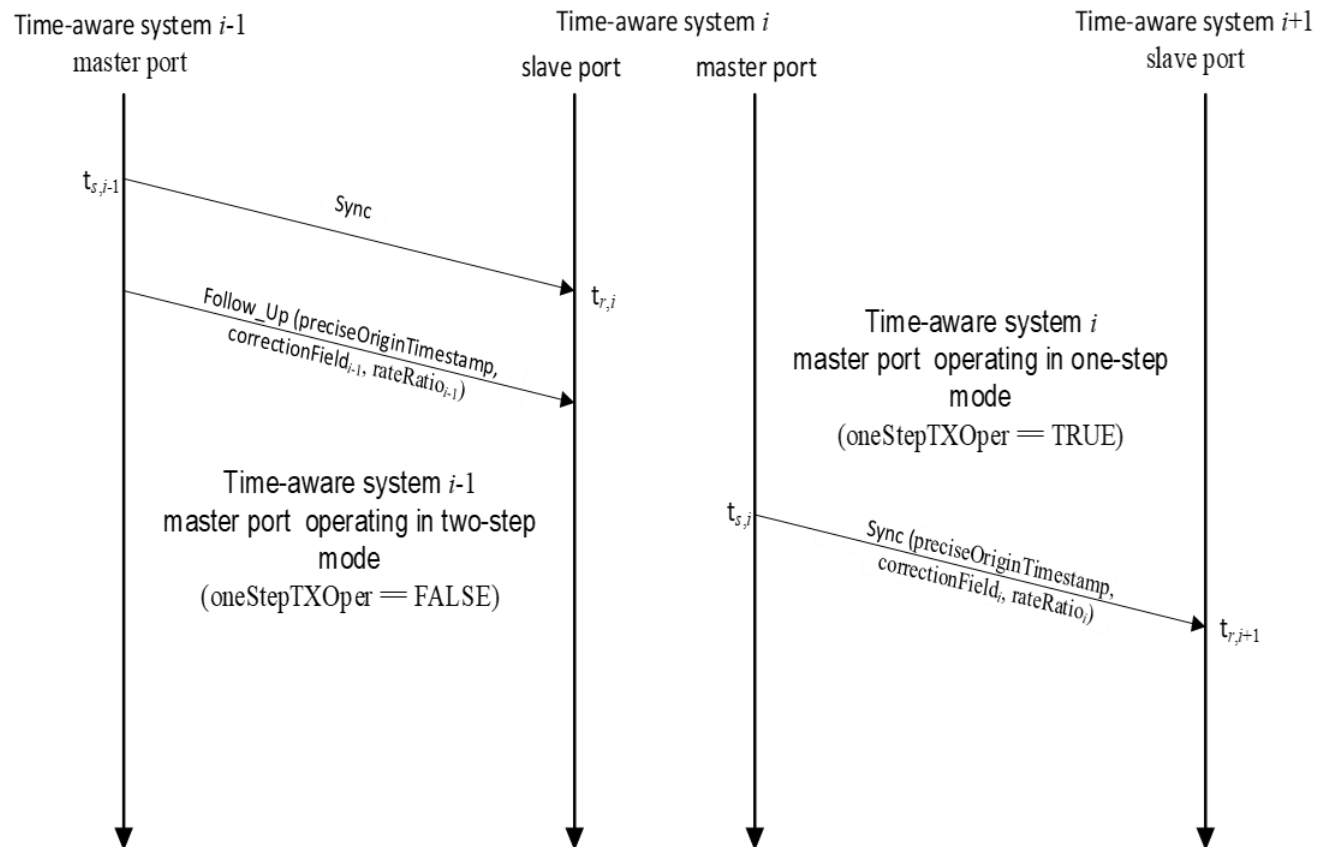

- **Master port of system  $i-1$  sends Sync message**
  - If one-step, Sync contains timestamp of when message was sent relative to Grandmaster (GM)
  - If two-step, timestamp relative to GM is sent in separate Follow\_Up message associated with the Sync message
- **Slave port of system  $i$  receives and timestamps Sync message relative to local clock**
- **Offset of system  $i$  relative to GM = (receive timestamp) – (send timestamp) – (mean link delay relative to GM) – (asymmetry correction if known, relative to GM)**
- **Offset is used to compute time at system  $i$  relative to GM, at instant Sync message is received**
- **When system  $i$  sends Sync message to system  $i+1$ , GM time is computed as (GM time when most recent Sync message was received) + (accumulated rate ratio relative to master)([send time relative to local clock] – [receipt time of most recent Sync relative to local clock])**
  - This GM time is placed in Sync message sent to  $i+1$
- **GM time is filtered (e.g., by PLL/servo) before being provided to end application (but not in computing master time sent to  $i+1$ )**



# 802.1AS – PTP Architecture Layering

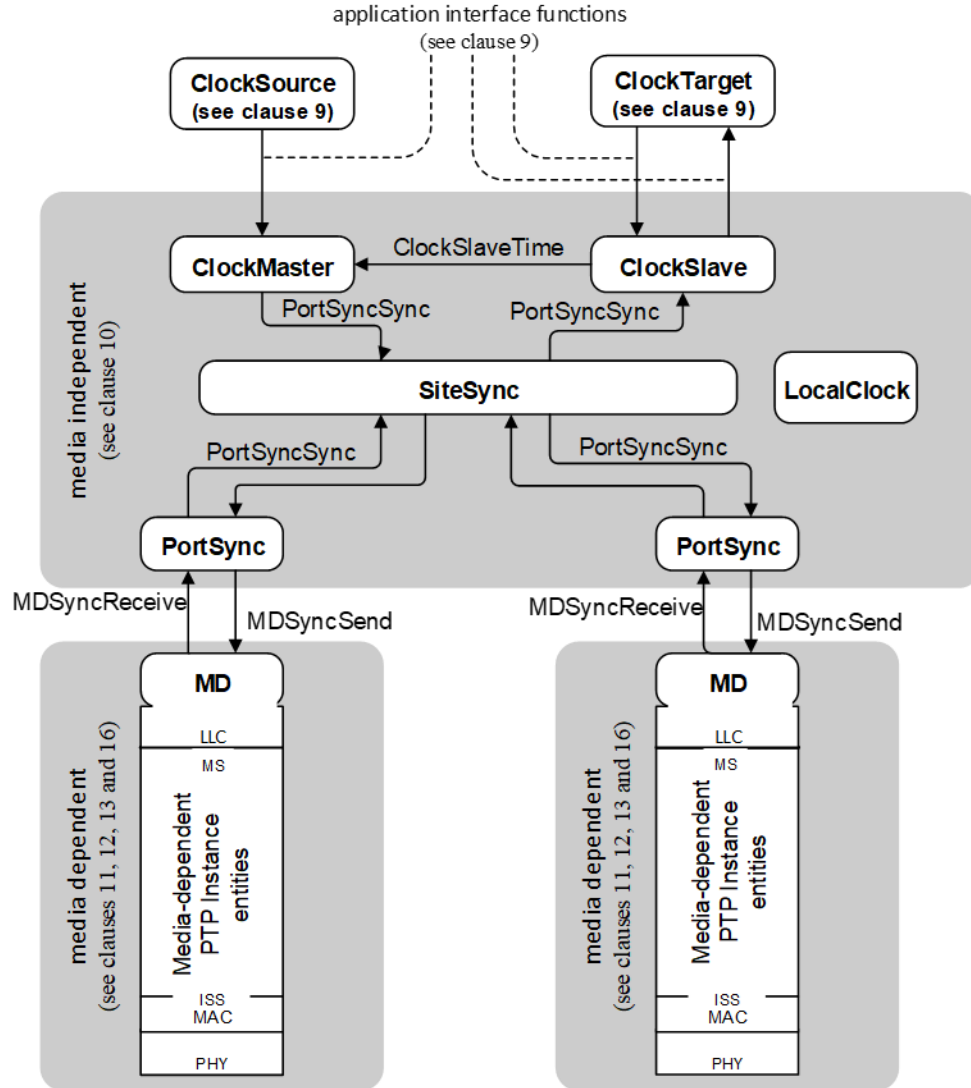

- 802.1AS architecture is divided into media-independent and media-dependent layers
- This division was made because certain media, e.g., IEEE 802.11, IEEE 802.3 EPON, Coordinated Shared Network (e.g., MoCA), have inherent time transport mechanisms (i.e., other than IEEE 1588)
  - These mechanisms allow the endpoints of a link to be synchronized, but do not provide for end-to-end network synchronization
  - The mechanisms were developed for media-specific reasons, e.g., location determination in 802.11
- The description on the previous slides uses the timing messages of IEEE 1588, and is used for full-duplex Ethernet transport (which does not have an inherent timing mechanism)
- Primitives are used to transfer media-independent information between the media-independent and media-dependent layers
  - The needed information is provided by the media-dependent layer in a common format
- The architecture also defines common (abstract) application interfaces

# 802.1AS – PTP Synchronization Spanning Tree

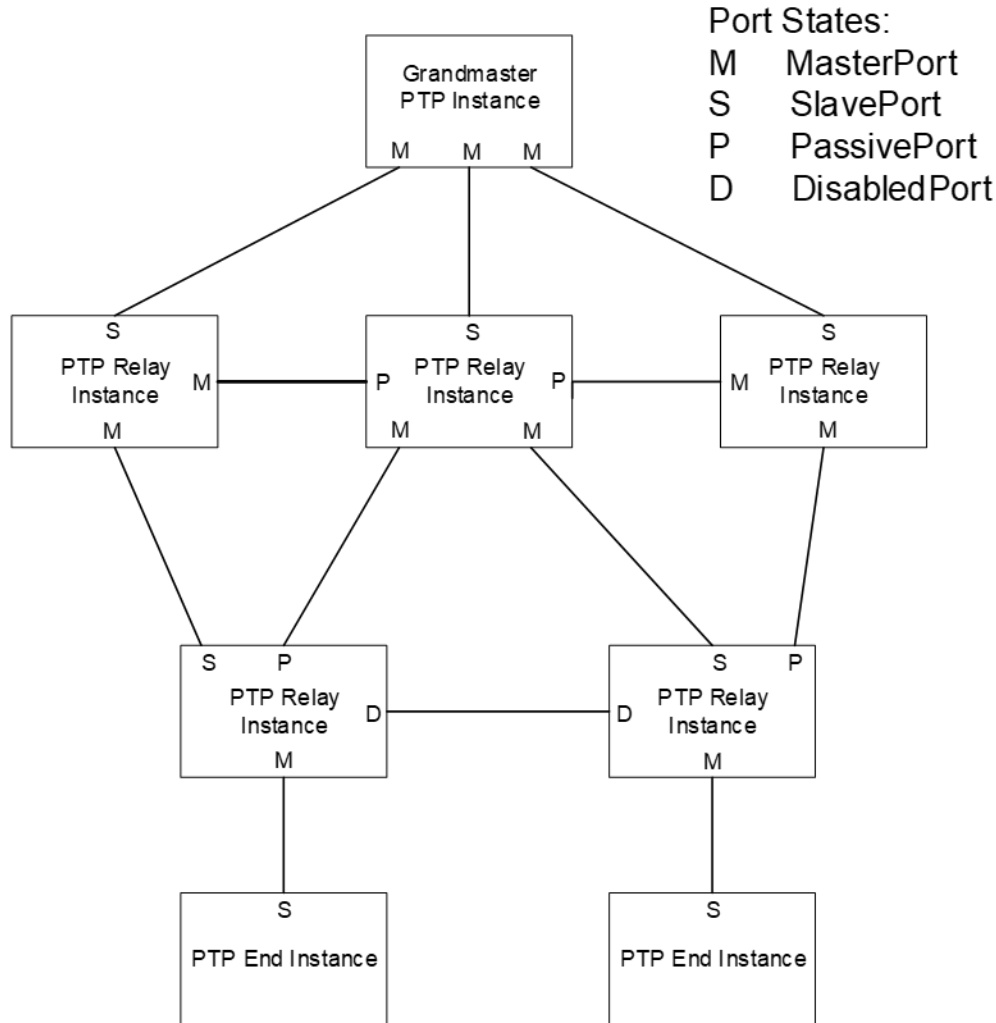

- 802.1AS uses the 1588 Best Master Clock Algorithm (BMCA) to form the synchronization hierarchy, i.e., spanning tree
- The BMCA is functionally equivalent to the portion of 802.1Q Rapid Spanning Tree Protocol (RSTP) that sets the 802.1Q port roles (called port states in 1588 and 802.1AS)
  - Note: It is planned to replace the terms master and slave with alternate terms, which will be recommended by an amendment to IEEE 1588-2019, that are more inclusive (see slide 19)

802.1/1588 Port States	
802.1AS/1588	Corresponding 802.1Q terminology
MasterPort	Designated Port
SlavePort	Root Port
PassivePort	Alternate Port

# 802.1AS – PTP Best Master Clock Algorithm

- Each MasterPort sends Announce messages to its neighboring port
- An Announce message that is sent contains attributes of the clock that was determined to be the best master clock, by running the BMCA
- On receipt of an Announce message, the BMCA is invoked, and port states are set
- The algorithm operates at each PTP Instance, and the network converges to a spanning tree with the best clock as the grandmaster (root)

Clock Attributes	
Priority1	Used to override all other attributes
ClockClass	Denotes the traceability of the clock
clockAccuracy	Denotes the time accuracy of the clock
offsetScaledLogVariance	Characterizes the frequency stability of the clock
Priority2	Used to set preferences among clocks for which the above attributes are the same
timeSource	Denotes the source of time (for information; not used for best master selection)

# New Features of IEEE Std 802.1AS-2020

---

# New Features of IEEE Std 802.1AS-2020

- External port configuration
  - Alternative to BMCA; can be used with external mechanism when redundancy is desired via multiple domains
- Fine Timing Measurement (FTM) for 802.11 transport
  - Provides improved time accuracy compared to Timing Measurement (TM) used in 802.1AS-2011
- Management support for delay asymmetry measurement (using line-swapping)
- Multiple domains
  - 1588-2008 allowed multiple domains, but 802.1AS-2011 was limited to a single domain (domain 0)
  - In a node that supports multiple domains, each domain is a separate instance of PTP (i.e., a separate PTP Instance)
- Common mean link delay service to make mean link delay measurements that are common across all domains
  - This is useful because mean link delay for 802.3 transport depends on the physical characteristics of the link and should not vary from one domain (PTP Instance) to another
- One-step ports (1588-2008 allowed one-step clocks, but 802.1AS-2011 was limited to two-step)
- Automatic signaling of 802.1AS capability and determination of whether the port at the other end of the link is capable of executing the 802.1AS protocol

# 802.1AS-2020 – Multiple Domains

- Every time-aware system supports domain 0 (for backward compatibility with 802.1AS-2011)
- In this example:
  - Some time-aware systems support two domains, but have only one domain active
  - Domains 0 and 1 could use different timescales

Note: all the “bridges” and “routers” in this figure are examples of time-aware systems that contain at least one PTP Relay Instance, and the end stations are time-aware systems that contain at least one PTP End Instance.

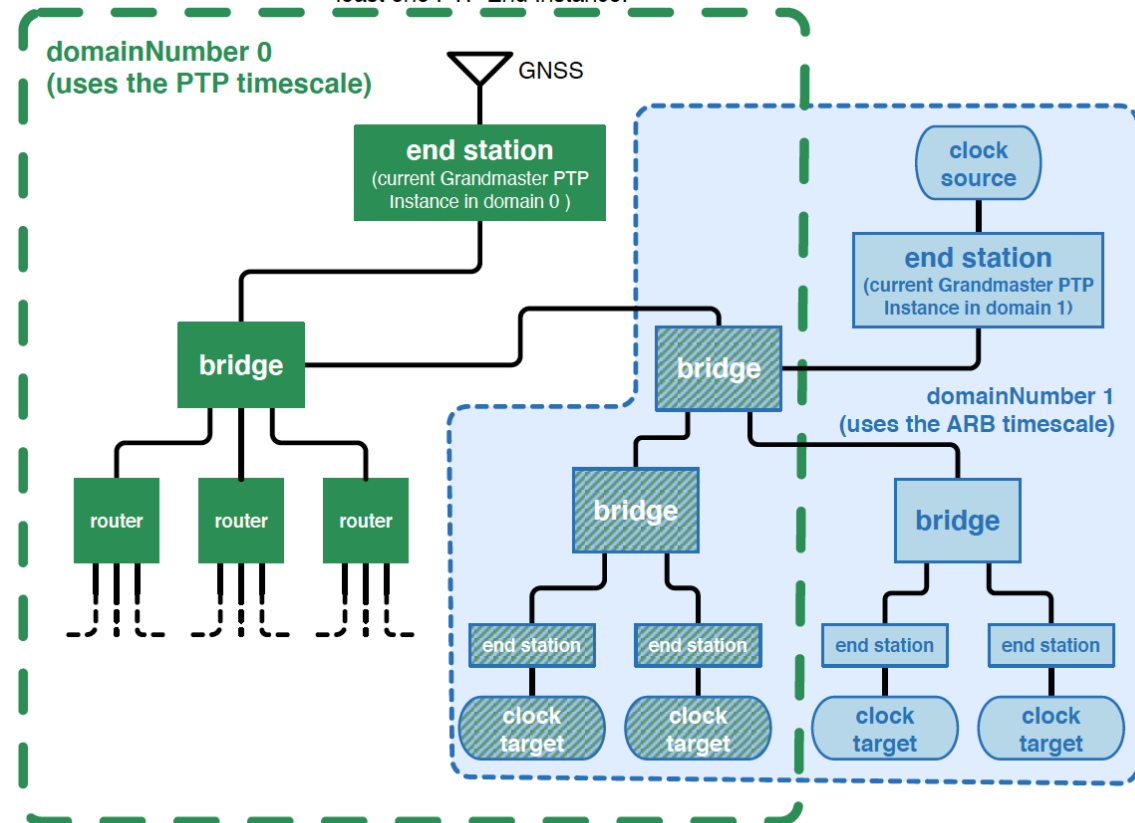
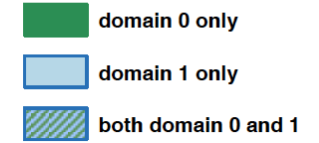

# New work items for IEEE Std 802.1AS

---

## P802.1ASdn

- A PAR was approved for an amendment to IEEE Std 802.1AS-2020 to specify a YANG data model to support configuration and state reporting via the managed objects of IEEE Std 802.1AS
- The YANG data model in this amendment augments the YANG for IEEE Std 1588 ([P1588e](#))
  - P1588e is an amendment to specify MIB and YANG data models for all data sets of IEEE Std 1588-2019. It is a work in progress—in the P1588 Working group

## **P802.1ASds**

- A PAR was approved for an amendment to IEEE Std 802.1AS-2020 to support IEEE Std 802.3 Clause 4 Media Access Control (MAC) operating in half-duplex
- There is interest in having IEEE Std 802.1AS support 10BASE-T1S type of technology, specially for Automotive applications

## P802.1ASdr

- A Project Authorization Request (PAR) was approved for an amendment to IEEE Std 802.1AS-2020 to change non-inclusive, insensitive terminology such as “master” and “slave”

## P802.1ASdm

- A PAR was approved for an amendment to IEEE Std 802.1AS-2020 to support hot standby
- The hot standby function provides an enhanced PTP time redundancy for the application, e.g., industrial or automotive cases.



- The scope of the project is as follows:
  - “This amendment changes the non-inclusive, insensitive, and deprecated terminology including those identified by IEEE P1588g and IEEE editorial staff, replacing them with their suitable terminology wherever possible”
- The amendment depends on the alternative terminology selected by the IEEE P1588 working group ([P1588g](#) project)
  - A new alternative terminology to master-slave was selected in a straw poll run-off, and it will be used as a basis for P1588g draft amendment.
    - “timeTransmitter” was selected as an alternative nomenclature for “master”
    - “timeReceiver” was selected as an alternative nomenclature for “slave”
  - A Working Group ballot with the new terms will take place as soon as the P1588g draft is ready
  - The initial P802.1ASdr draft will be created based on the P1588g alternative nomenclature

# P802.1ASdm – Hot Standby Overview

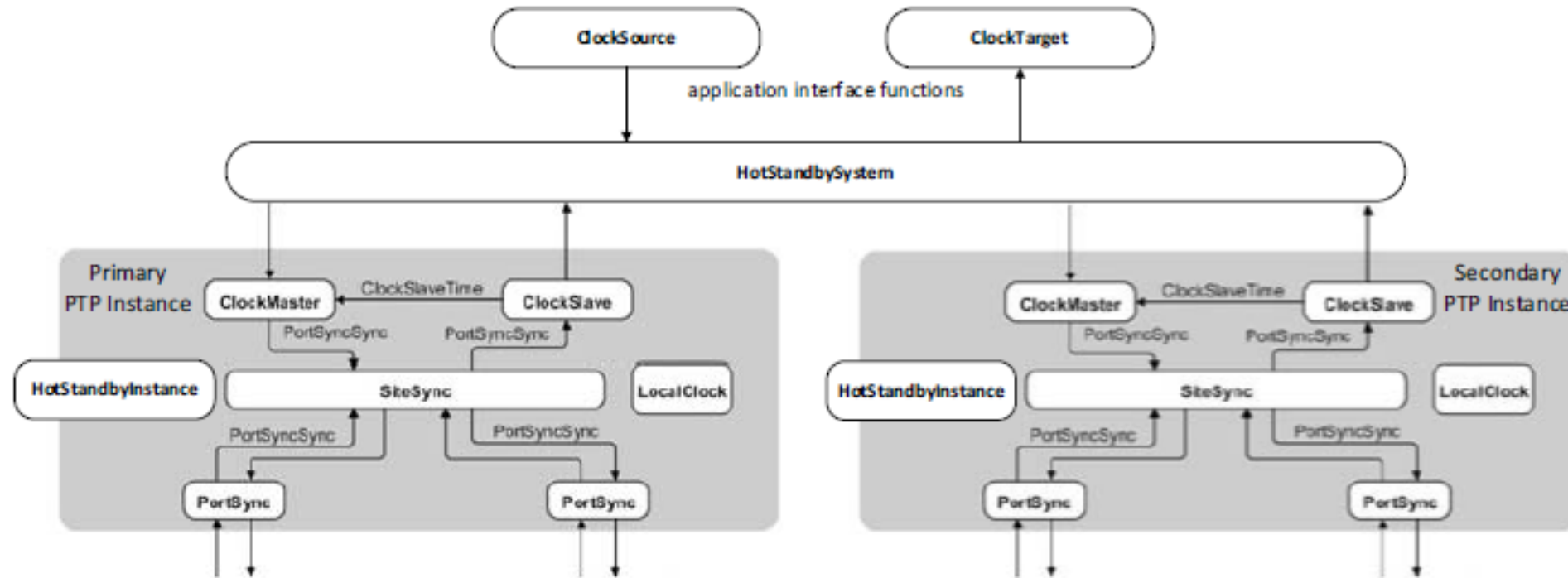

- The PTP Instances of a Hot standby time-aware system do not run BMCA, they use external port configuration
- Two independent domains are used, and two grandmasters operate independently and simultaneously, with one in each domain
  - The secondary grandmaster gets its time from the primary domain, and therefore will have the same time as the primary grandmaster
  - If the primary grandmaster fails, then the synchronization is provided by the secondary grandmaster
  - A split function is being defined to provide an enhanced mitigation scheme for grandmaster or link failures

# P802.1ASdm – Hot Standby Split function

- The split function provides enhanced mitigation scheme for grandmaster and link failures
- An Interworking function (IWF) is used to transfer time synchronization information from the primary to the secondary in case of failure of the secondary
  - There is no synchronization disruption for the end application
  - Especially important for Industrial Automation applications

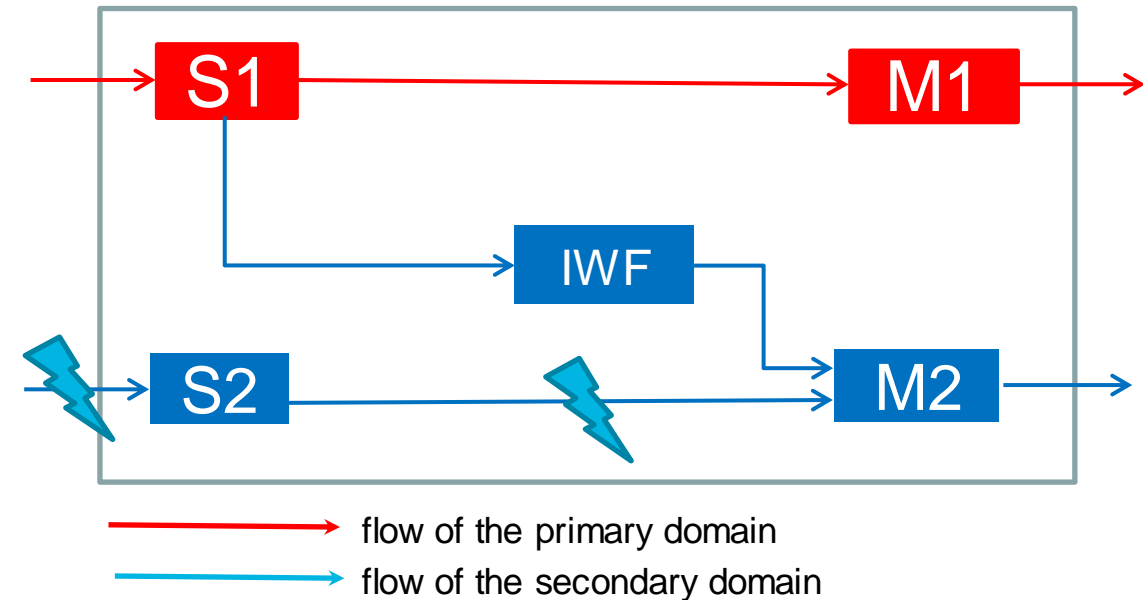

# IEC/IEEE 60802 TSN Profile for Industrial Automation

---

Focusing on the synchronization aspects of the profile

# IEC/IEEE 60802 TSN Profile for Industrial Automation – Overview

- The scope of the project is as follows:  
“This standard defines time-sensitive networking profiles for industrial automation. The profiles select features, options, configurations, defaults, protocols, and procedures of bridges, end stations, and LANs to build industrial automation networks.”
- Industrial Automation contains multiple tasks that are based on time or cycles
  - E.g., tasks in a control loop
- The data flow needs to operate continuously and relies on regular updates based on a local or network time base
- Latency and time delays are critical and need to be minimized and bounded

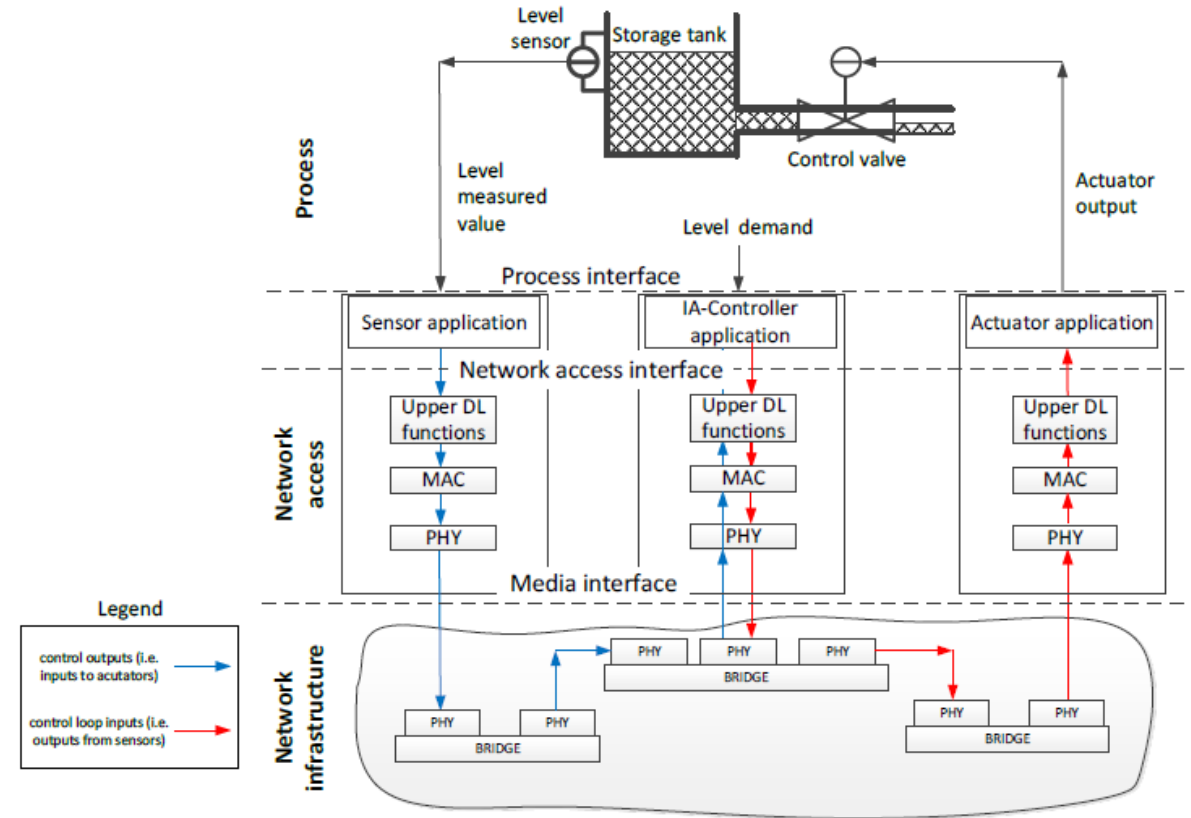

Figure 1 – Data flow in a control loop

Source: [IEC/IEEE 60802 D1.3 draft](#)

# IEC/IEEE 60802 TSN Profile for Industrial Automation – Synchronization Requirements – 1

- Industrial Automation tasks depend on synchronized time
  - Global Time – synchronized time traceable to a known source (TAI\*)
  - Working Clock – synchronized time traceable to an ARB timescale
- IA-devices need to ensure that time is always available
  - It could be based on a grandmaster clock
  - It could be based on an internal clock

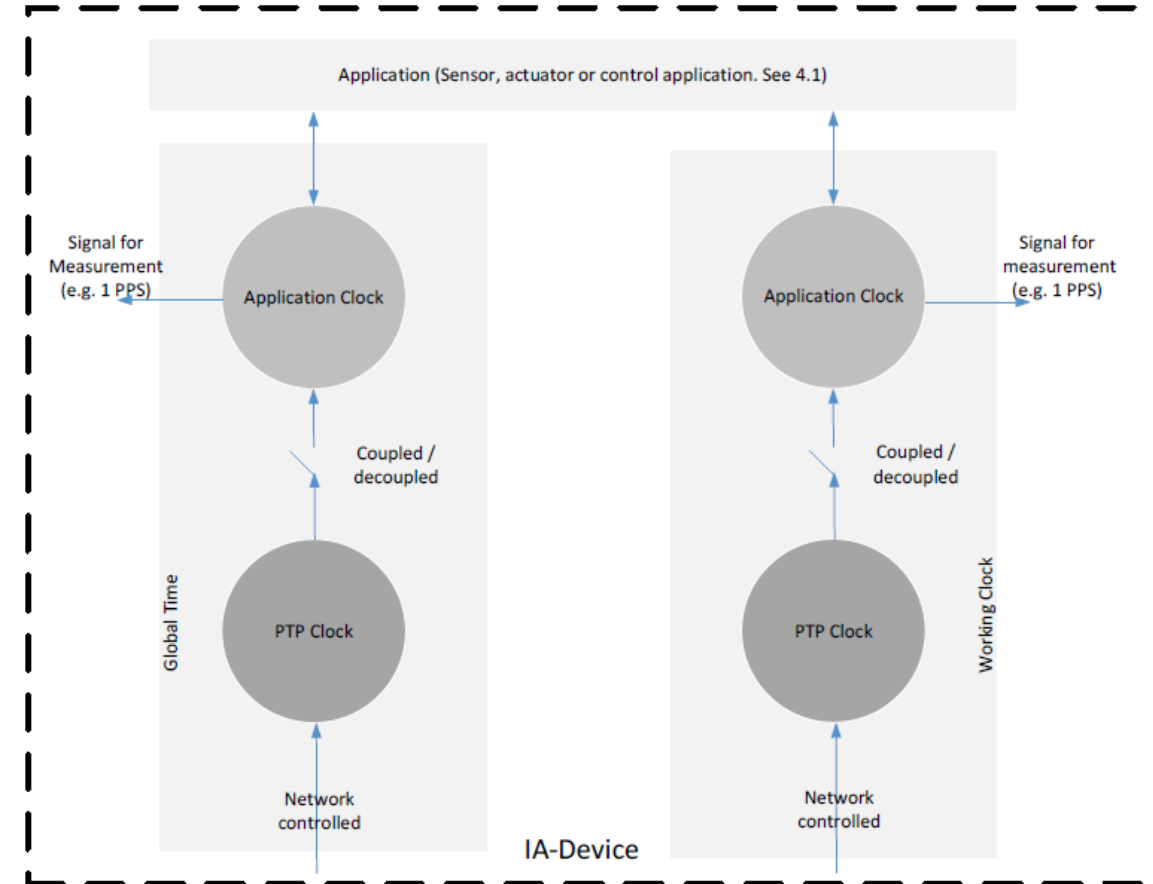
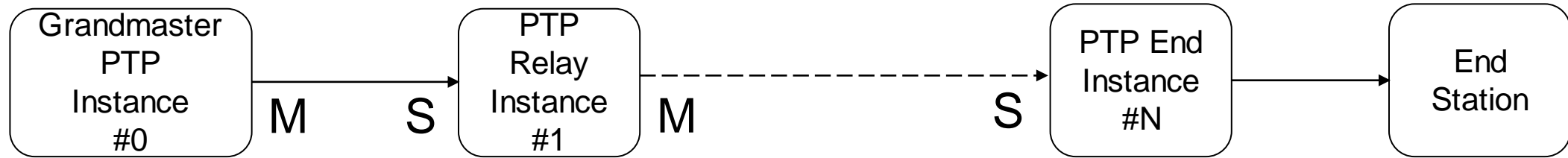

Figure 7 – Clock usage principles

Source: IEC/IEEE 60802 D1.3 draft

\*TAI – International Atomic Time

# IEC/IEEE 60802 TSN Profile for Industrial Automation – Synchronization Requirements – 2



- For the Working Clock domain, the network between the Grandmaster PTP Instance and any PTP End Instance (i.e., the value of N above) must support at least 64 nodes, and ideally 100 nodes
  - The synchronization requirement for this network is that the maximum absolute value of time error must not exceed 1  $\mu$ s
  - Simulations are being run to establish parameters for the profile using IEEE Std 802.1AS
- Hypothetical Reference Model for the simulations includes 101 nodes
  - A specific temperature profile for the local oscillator
  - Mean Sync interval
  - Mean Pdelay interval
  - Timestamp granularity
  - Residence times
  - Timestamp error

# IEEE P802.1DG TSN Profile for Automotive

---

Focusing on the synchronization aspects of the profile



# P802.1DG TSN Profile for Automotive In-Vehicle Ethernet Communications – Overview

- The scope of [P802.1DG](#) project is as follows:  
“This standard specifies profiles for secure, highly reliable, deterministic latency, automotive in-vehicle bridged IEEE 802.3 Ethernet networks based on IEEE 802.1 Time-Sensitive Networking (TSN) standards and IEEE 802.1 Security standards.”
- It is targeting Ethernet networks to support in-vehicle applications
- Networks in the car are well defined networks, they are pre-configured by the car manufacturers
  - The network topology of a particular in-vehicle is known at design time and it should not change



Source of this picture: Don Pannell, NXP Semiconductors, [dg-pannell-ChoosingTheRightTSNToolsToMeetABoundedLatency-whitePaper-0821-v01](#)

Three profiles are currently being addressed in the P802.1DG draft

### Base Profile

- It defines a set of minimum requirements for an implementation of TSN technology in a vehicle
  - Infotainment (time synchronization and traffic shaping for media streaming)
  - Advanced Driver Assistance Systems (ADAS) (time synchronization and traffic shaping for handling sensor data)
  - Security (Ingress policing for device failures, Denial-of-Service attacks).

### Extended Profile

- It supports all the requirements of the base profile
- Adds more TSN capabilities to support autonomous driving and next generation architectures
  - Fault tolerance and deterministic low latency

### Profile for Audio Systems

- It is targeting requirements for in-vehicle Audio Systems using TSN technology

- Synchronization is a key aspect of P802.1DG
  - It allows audio and video from several sources to be synchronized with each other (e.g. front and back screens and several points of audio in-vehicle)
  - It allows data sampling and delivery based on a common time base (important for Vehicle-to-Everything (V2x) applications)
- IEEE 802.1AS is a key part of P802.1DG
  - Best Master Clock Algorithm (BMCA), is it needed in the car?
  - What is the required synchronization performance in the car?
    - To address audio and video applications 1  $\mu$ s has been proposed
  - PTP Message rates need to be defined to meet the desired requirements

# IEEE P802.1DP / SAE AS6675 TSN Profile for Aerospace

---

- [IEEE P802.1DP / SAE AS6675](#) is a joint project of IEEE 802 and SAE Avionics Networks AS-1 A2 to define TSN profiles for aerospace.
- The scope of the project is as follows:
  - “This standard specifies profiles of IEEE 802.1 Time-Sensitive Networking (TSN) and IEEE 802.1 Security standards for aerospace onboard bridged IEEE 802.3 Ethernet networks. The profiles select features, options, configurations, defaults, protocols, and procedures of bridges, end stations, and Local Area Networks to build deterministic networks for aerospace onboard communications.”
- It is targeting Ethernet networks to support for aerospace applications
- Use of IEEE 802.1AS for synchronization for the synchronous profile

# UPCOMING WEBINARS

---

**Audio Video Bridging – IEEE Std 802.1BA**

**Fronthaul – IEEE Std 802.1CM**

**Industrial Automation – IEC/IEEE 60802**

**Automotive Ethernet – IEEE P802.1DG**

**Aerospace Ethernet – IEEE P802.1DP / SAE AS6675**

# THANK YOU

---

Geoff Garner  
Consultant  
Huawei

[gmgarner@alum.mit.edu](mailto:gmgarner@alum.mit.edu)

<https://www.huawei.com/us/>

<https://www.linkedin.com/in/geoffrey-garner-7b93564/>

Silvana Rodrigues  
Senior Principal Engineer  
Huawei

[Silvana.rodrigues@Huawei.com](mailto:Silvana.rodrigues@Huawei.com)

<https://www.huawei.com/ca/>

<https://www.linkedin.com/in/silvana-rodrigues-8a72271/>

IEEE 802.1: <http://www.ieee802.org/1>

Foundational Technologies: <https://standards.ieee.org/practices/foundational/index.html>

Standards Home Page: <https://standards.ieee.org>