

## 64. Multipoint MAC Control

NOTE—The editing instructions contained in this amendment define how to merge the material contained therein into the existing base standard and its amendments to form the comprehensive standard.

The editing instructions are shown in *bold italic*. Four editing instructions are used: change, delete, insert, and replace. *Change* is used to make corrections in existing text or tables. The editing instruction specifies the location of the change and describes what is being changed by using ~~strickthrough~~ (to remove old material) and underline (to add new material). *Delete* removes existing material. *Insert* adds new material without disturbing the existing material. Insertions may require renumbering. If so, renumbering instructions are given in the editing instruction. *Replace* is used to make changes in figures or equations by removing the existing figure or equation and replacing it with a new one. Editorial notes will not be carried over into future editions because the changes will be incorporated into the base standard.

### 64.1 Overview

This clause deals with the mechanism and control protocols required in order to reconcile the P2MP topology into the Ethernet framework. The P2MP medium is a passive optical network (PON), an optical network with no active elements in the signal's paths from source to destination. The only interior elements used in a PON are passive optical components, such as optical fiber, splices, and splitters. When combined with the Ethernet protocol, such a network is referred to as Ethernet passive optical network (EPON).

P2MP is an asymmetrical medium based on a tree (or tree-and-branch) topology. The DTE connected to the trunk of the tree is called optical line terminal (OLT) and the DTEs connected at the branches of the tree are called optical network units (ONU). The OLT typically resides at the service provider's facility, while the ONUs are located at the subscriber premises.

In the downstream direction (from the OLT to an ONU), signals transmitted by the OLT pass through a 1:N passive splitter (or cascade of splitters) and reach each ONU. In the upstream direction (from the ONUs to the OLT), the signal transmitted by an ONU would only reach the OLT, but not other ONUs. To avoid data collisions and increase the efficiency of the subscriber access network, ONU's transmissions are arbitrated. This arbitration is achieved by allocating a transmission window (grant) to each ONU. An ONU defers transmission until its grant arrives. When the grant arrives, the ONU transmits frames at wire speed during its assigned time slot.

A simplified P2MP topology example is depicted in Figure 64–1. Clause 67 provides additional examples of P2MP topologies.

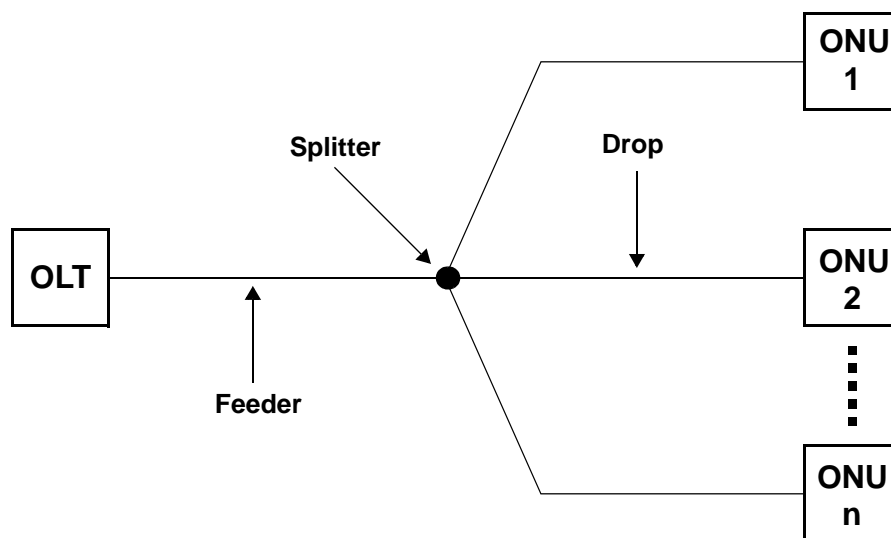

Figure 64–1—PON topology example

1 Topics dealt with in this clause include allocation of upstream transmission resources to different ONUs,  
2 discovery and registration of ONUs into the network, and reporting of congestion to higher layers to allow  
3 for dynamic bandwidth allocation schemes and statistical multiplexing across the PON.

4  
5 This clause does not deal with topics including bandwidth allocation strategies, authentication of end-  
6 devices, quality-of-service definition, provisioning, or management.

7  
8 This clause specifies the multipoint control protocol (MPCP) to operate an optical multipoint network by  
9 defining a Multipoint MAC Control sublayer as an extension of the MAC Control sublayer defined in  
10 Clause 31, and supporting current and future operations as defined in Clause 31 and annexes.

11  
12 Each PON consists of a node located at the root of the tree assuming the role of OLT, and multiple nodes  
13 located at the tree leaves assuming roles of ONUs. The network operates by allowing only a single ONU to  
14 transmit in the upstream direction at a time. The MPCP located at the OLT is responsible for timing the  
15 different transmissions. Reporting of congestion by the different ONUs may assist in optimally allocating  
16 the bandwidth across the PON.

17  
18 Automatic discovery of end stations is performed, culminating in registration through binding of an ONU to  
19 an OLT port by allocation of a Logical Link ID (see LLID in 65.1.3.3.2), and dynamic binding to a MAC  
20 connected to the OLT.

21  
22 The Multipoint MAC Control functionality shall be implemented for subscriber access devices containing  
23 point-to-multipoint physical layer devices defined in Clause 60.

#### 24 25 **64.1.1 Goals and objectives**

26  
27 The goals and objectives of this clause are the definition of a point-to-multipoint Ethernet network utilizing  
28 an optical medium.

29  
30 Specific objectives met include:

- 31 a) Support of Point-to-Point Emulation (P2PE) as specified
- 32 b) Support multiple LLIDs and MAC Clients at the OLT
- 33 c) Support a single LLID per ONU
- 34 d) Support a mechanism for single copy broadcast
- 35 e) Flexible architecture allowing dynamic allocation of bandwidth
- 36 f) Use of 32 bit timestamp for timing distribution
- 37 g) MAC Control based architecture
- 38 h) Ranging of discovered devices for improved network performance
- 39 i) Continuous ranging for compensating round trip time variation

#### 40 41 **64.1.2 Position of Multipoint MAC Control within the IEEE 802.3 hierarchy**

42  
43 Multipoint MAC Control defines the MAC control operation for optical point-to-multipoint networks.  
44 Figure 64-2 depicts the architectural positioning of the Multipoint MAC Control sublayer with respect to  
45 the MAC and the MAC Control client. The Multipoint MAC Control sublayer takes the place of the MAC  
46 Control sublayer to extend it to support multiple clients and additional MAC control functionality.

47  
48 Multipoint MAC Control is defined using the mechanisms and precedents of the MAC Control sublayer.  
49 The MAC Control sublayer has extensive functionality designed to manage the real-time control and  
50 manipulation of MAC sublayer operation. This clause specifies the extension of the MAC Control  
51 mechanism to manipulate multiple underlying MACs simultaneously. This clause also specifies a specific  
52 protocol implementation for MAC Control.

The Multipoint MAC Control sublayer is specified such that it can support new functions to be implemented and added to this standard in the future. MultiPoint Control Protocol (MPCP), the management protocol for P2MP is one of these protocols. Non-real-time, or quasi-static control (e.g., configuration of MAC operational parameters) is provided by Layer Management. Operation of the Multipoint MAC Control sublayer is transparent to the MAC.

As depicted in Figure 64–2, the layered system instantiates multiple MAC entities, using a single physical layer. The individual MAC instances offer a Point-to-point emulation service between the OLT and the ONU. Two additional MACs are instantiated: one MAC instance to communicate to all 1000 Mb/s downstream ONUs and another MAC instance to communicate to 10 Gb/s downstream ONUs. The said MAC instances take maximum advantage of the broadcast nature of the downstream channel by sending a single copy of a frame that is received by all ONUs. These MAC instances are referred to as Single Copy Broadcast (SCB).

The ONU only requires one MAC instance since frame filtering operations are done at the RS layer before reaching the MAC. Therefore, MAC and layers above are emulation-agnostic at the ONU (see 65.1.3.3).

Although Figure 64–2 and supporting text describe multiple MACs within the OLT, a single unicast MAC address may be used by the OLT. Within the EPON Network, MACs are uniquely identified by their LLID which is dynamically assigned by the registration process.

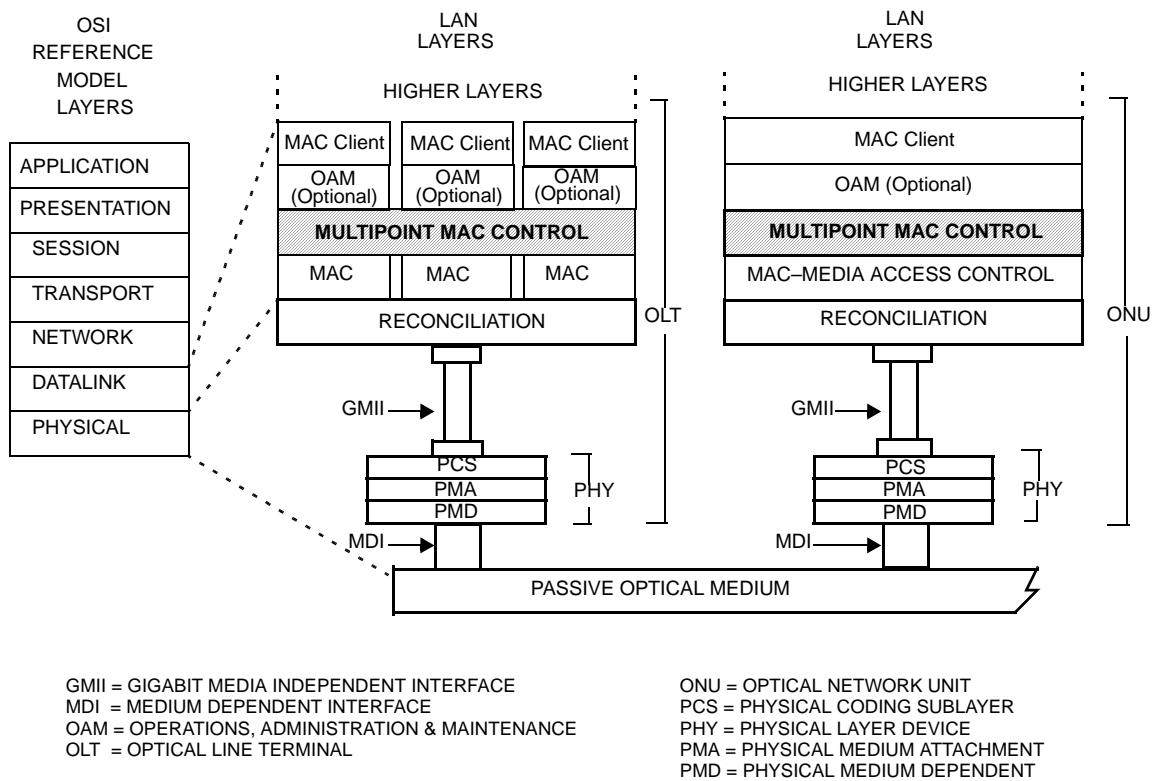

**Figure 64–2—Relationship of Multipoint MAC Control and the OSI protocol stack**

### 64.1.3 Functional block diagram

Figure 64–3 provides a functional block diagram of the Multipoint MAC Control architecture.

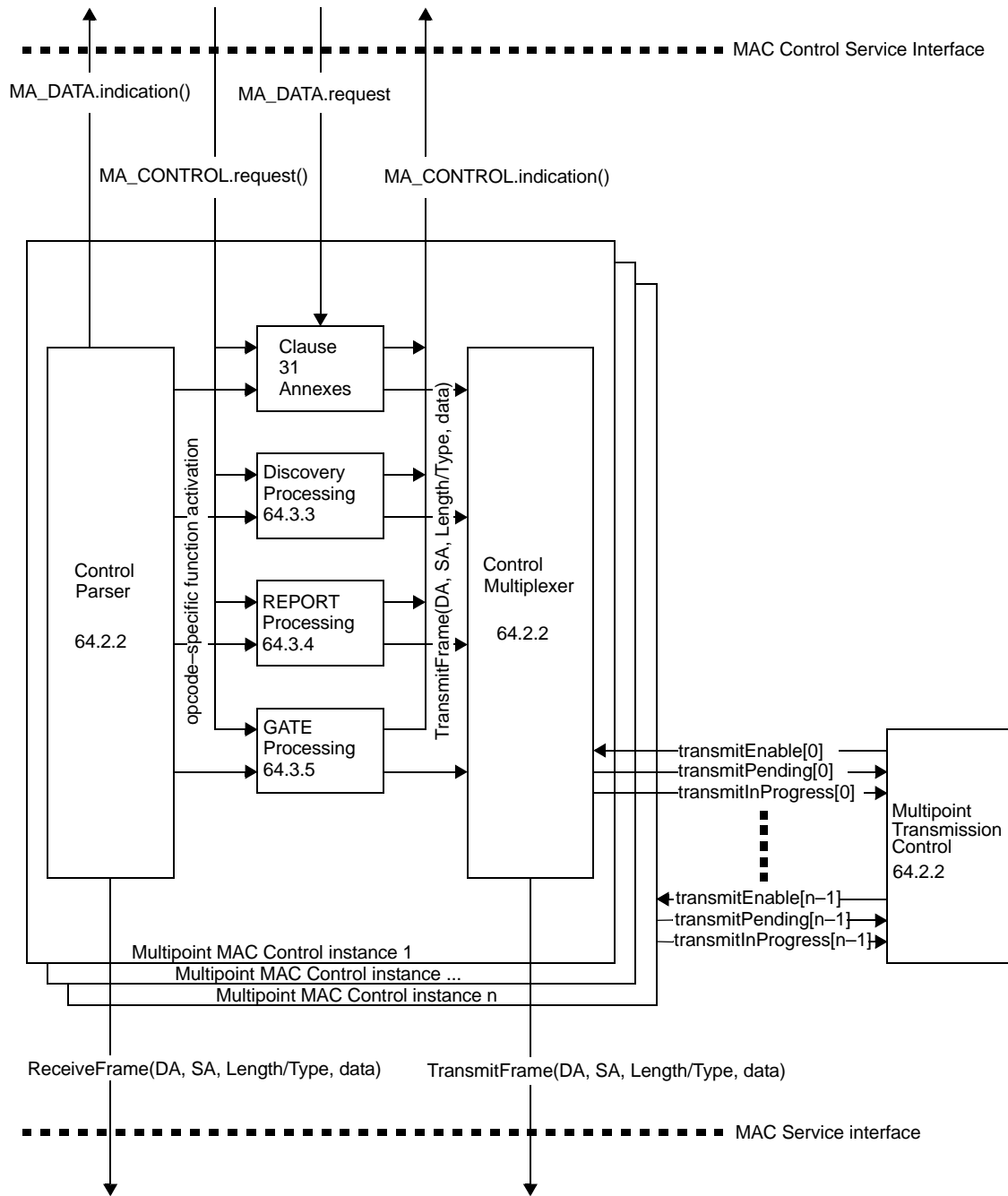

Figure 64–3—Multipoint MAC Control Functional Block Diagram

## 64.1.4 Service interfaces

The MAC Client communicates with the Control Multiplexer using the standard service interface specified in 2.3. Multipoint MAC Control communicates with the underlying MAC sublayer using the standard service interface specified in 4A.3.2. Similarly, Multipoint MAC Control communicates internally using primitives and interfaces consistent with definitions in Clause 31.

## 64.1.5 State diagram conventions

The body of this standard comprises state diagrams, including the associated definitions of variables, constants, and functions. Should there be a discrepancy between a state diagram and descriptive text, the state diagram prevails.

The notation used in the state diagrams follows the conventions of 21.5. State diagram timers follow the conventions of 14.2.3.2 augmented as follows:

- a) [start  $x\_timer$ ,  $y$ ] sets expiration of  $y$  to timer  $x\_timer$ .
- b) [stop  $x\_timer$ ] aborts the timer operation for  $x\_timer$  asserting  $x\_timer\_not\_done$  indefinitely.

The state diagrams use an abbreviation MACR as a shorthand form for MA\_CONTROL.request and MACI as a shorthand form for MA\_CONTROL.indication.

The vector notations used in the state diagrams for bit vector use 0 to mark the first received bit and so on (for example data[0:15]), following the conventions of 3.1 for bit ordering. When referring to an octet vector, 0 is used to mark the first received octet and so on (for example m\_sdu[0..1]).

$a < b$ : A function that is used to compare two (cyclic) time values. Returned value is true when  $b$  is larger than  $a$  allowing for wrap around of  $a$  and  $b$ . The comparison is made by subtracting  $b$  from  $a$  and testing the MSB. When  $MSB(a-b) = 1$  the value true is returned, else false is returned. In addition, the following functions are defined in terms of  $a < b$ :

- $a > b$  is equivalent to  $!(a < b \text{ or } a = b)$
- $a \geq b$  is equivalent to  $!(a < b)$
- $a \leq b$  is equivalent to  $!(a > b)$

## 64.2 Multipoint MAC Control operation

As depicted in Figure 64–3, the Multipoint MAC Control functional block comprises the following functions:

- a) *Multipoint Transmission Control*. This block is responsible for synchronizing Multipoint MAC Control instances associated with the Multipoint MAC Control. This block maintains the Multipoint MAC Control state and controls the multiplexing functions of the instantiated MACs.
- b) *Multipoint MAC Control Instance  $n$* . This block is instantiated for each MAC and respective MAC and MAC Control clients associated with the Multipoint MAC Control. It holds all the variables and state associated with operating all MAC Control protocols for the instance.
- c) *Control Parser*. This block is responsible for parsing MAC Control frames, and interfacing with Clause 31 entities, the opcode specific blocks, and the MAC Client.
- d) *Control Multiplexer*. This block is responsible for selecting the source of the forwarded frames.
- e) *Clause 31 Annexes*. This block holds MAC Control actions as defined in Clause 31 annexes for support of legacy and future services.
- f) *Discovery, Report and Gate Processing*. These blocks are responsible for handling the MPCP in the context of the MAC.

## 64.2.1 Principles of Multipoint MAC Control

As depicted in Figure 64–3, Multipoint MAC Control sublayer may instantiate multiple Multipoint MAC Control instances in order to interface multiple MAC and MAC Control clients above with multiple MACs below. A unique unicast MAC instance is used at the OLT to communicate with each ONU. The individual MAC instances utilize the point-to-point emulation service between the OLT and the ONU as defined in 65.1.

At the ONU, a single MAC instance is used to communicate with a MAC instance at the OLT. In that case, the Multipoint MAC Control contains only a single instance of the Control Parser/Multiplexer function.

Multipoint MAC Control protocol supports several MAC and client interfaces. Only a single MAC interface and Client interface is enabled for transmission at a time. There is a tight mapping between a MAC service interface and a Client service interface. In particular, the assertion of the ReceiveFrame interface in MAC *j* enables the indication interface of Client *j*. Conversely, the assertion of the request service interface in Client *i* enables the TransmitFrame interface of MAC *i*. Note that the Multipoint MAC sublayer need not receive and transmit packets associated with the same interface at the same time. Thus the Multipoint MAC Control acts like multiple MAC Controls bound together with common elements.

The scheduling algorithm is implementation dependent, and is not specified for the case where multiple transmit requests happen at the same time.

The reception operation is as follows. The Multipoint MAC Control instances generate ReceiveFrame function calls continuously to the underlying MAC instances. Since these MACs are receiving frames from a single PHY only one frame is passed from the MAC instances to Multipoint MAC Control. The MAC instance responding to the ReceiveFrame is referred to as the enabled MAC, and its service interface is referred to as the enabled MAC interface. The MAC passes to the Multipoint MAC Control sublayer all valid frames. Invalid frames, as specified in 3.4, are not passed to the Multipoint MAC Control sublayer in response to a ReceiveFrame function call.

The enabling of a transmit service interface is performed by the Multipoint MAC Control instance in collaboration with the Multipoint Transmission Control. Frames generated in the MAC Control are given priority over MAC Client frames, in effect, prioritizing the MA\_CONTROL primitive over the MA\_DATA primitive, and for this purpose MA\_DATA.request primitives may be delayed, discarded or modified in order to perform the requested MAC Control function. For the transmission of this frame, the Multipoint MAC Control instance enables forwarding by the MAC Control functions, but the MAC Client interface is not enabled. The reception of a frame in a MAC enables the ReceiveFrame interface of the MAC. Only one receive MAC interface will be enabled at any given time since there is only one PHY interface.

The information of the enabled interfaces is stored in the controller state variables, and accessed by the Multiplexing Control block.

The Multipoint MAC Control sublayer uses the services of the underlying MAC sublayer to exchange both data and control frames.

Receive operation at each instance:

- a) A frame is received from the underlying MAC.
- b) The frame is parsed according to Length/Type field
- c) MAC Control frames are demultiplexed according to opcode and forwarded to the relevant processing functions
- d) Data frames are forwarded to the MAC Client by asserting MA\_DATA.indication primitives

Transmit operation at each instance:

- e) The MAC Client signals a frame transmission by asserting MA\_DATA.request, or
- f) A protocol processing block attempts to issue a frame, as a result of a previous MA\_CONTROL.request or as a result of an MPCP event that generates a frame.
- g) When allowed to transmit by the Multipoint Transmission Control block, the frame is forwarded.

### 64.2.1.1 Ranging and Timing Process

Both the OLT and the ONU have 32 bit counters that increment every 1 time\_quantum. These counters provide a local time stamp. When either device transmits an MPCPDU, it maps its counter value into the timestamp field. The time of transmission of the first octet of the MPCPDU frame from the MAC Control to the MAC is taken as the reference time used for setting the timestamp value.

When the ONU receives MPCPDUs, it sets its counter according to the value in the timestamp field in the received MPCPDU.

When the OLT receives MPCPDUs, it uses the received timestamp value to calculate or verify a round trip time between the OLT and the ONU. The RTT is equal to the difference between the timer value and the value in the timestamp field. The calculated RTT is notified to the client via the MA\_CONTROL.indication primitive. The client can use this RTT for the ranging process.

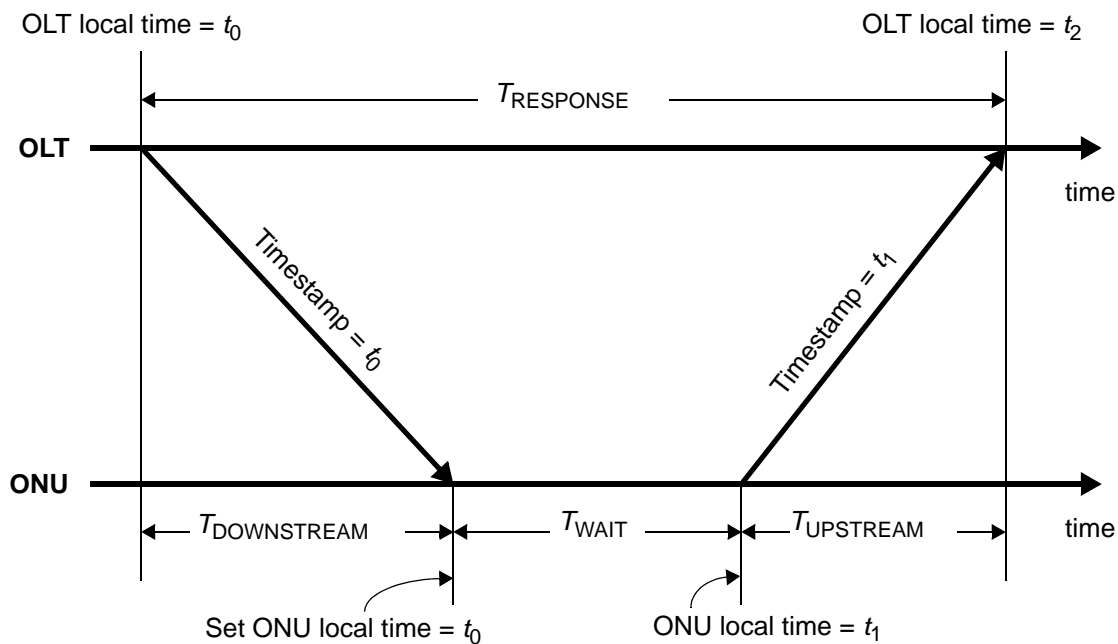

$T_{\text{DOWNSTREAM}}$  = downstream propagation delay

$T_{\text{UPSTREAM}}$  = upstream propagation delay

$T_{\text{WAIT}}$  = wait time at ONU =  $t_1 - t_0$

$T_{\text{RESPONSE}}$  = response time at OLT =  $t_2 - t_0$

$$RTT = T_{\text{DOWNSTREAM}} + T_{\text{UPSTREAM}} = T_{\text{RESPONSE}} - T_{\text{WAIT}} = (t_2 - t_0) - (t_1 - t_0) = t_2 - t_1$$

**Figure 64-4—Round trip time calculation**

A condition of *timestamp drift error* occurs when the difference between OLT's and ONU's clocks exceeds some predefined threshold. This condition can be independently detected by the OLT or an ONU. The OLT detects this condition when an absolute difference between new and old RTT values measured for a given ONU exceeds the value of guardThresholdOLT (see 64.2.2.1), as shown in Figure 64-10. An ONU detects

the timestamp drift error condition when absolute difference between a timestamp received in an MPCPDU and the localTime counter exceeds guardThresholdONU (see 64.2.2.1), as is shown in Figure 64–11.

**64.2.2 Multipoint transmission control, Control Parser, and Control Multiplexer**

The purpose of the multipoint transmission control is to allow only one of the multiple MAC clients to transmit to its associated MAC and subsequently to the RS layer at one time by only asserting one transmitEnable signal at a time.

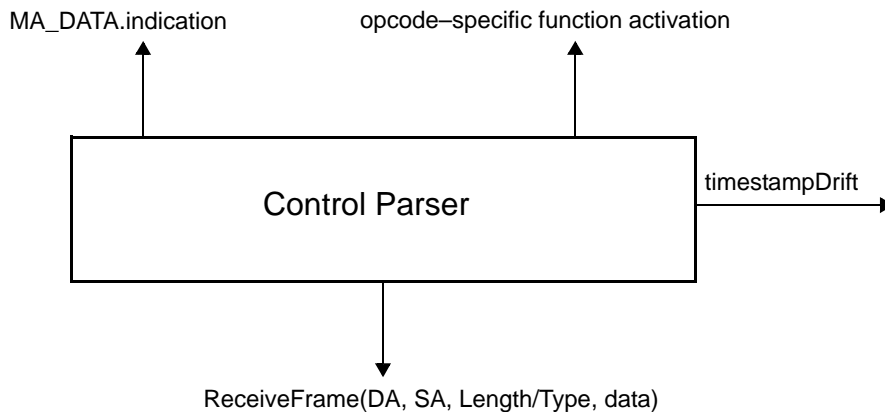

**Figure 64–5—Multipoint Transmission Control Service Interfaces**

Multipoint MAC Control Instance n function block communicates with the Multipoint Transmission Control using transmitEnable[n], transmitPending[n], and transmitInProgress[n] state variables (see Figure 64–3).

The Control Parser is responsible for opcode independent parsing of MAC frames in the reception path. By identifying MAC Control frames, demultiplexing into multiple entities for event handling is possible. Interfaces are provided to existing Clause 31 entities, functional blocks associated with MPCP, and the MAC Client.

The Control Multiplexer is responsible for forwarding frames from the MAC Control opcode-specific functions and the MAC Client to the MAC. Multiplexing is performed in the transmission direction. Given multiple MA\_DATA.request primitives from the MAC Client, and MA\_CONTROL.request primitives from the MAC Control Clients, a single TransmitFrame is generated for transmission. At the OLT, multiple MAC instances share the same Multipoint MAC Control, as a result, the transmit block is enabled based on an external control signal housed in Multipoint Transmission Control for transmission overlap avoidance. At the ONU the Gate Processing functional block interfaces for upstream transmission administration.



**Figure 64–6—Control Parser Service Interfaces**



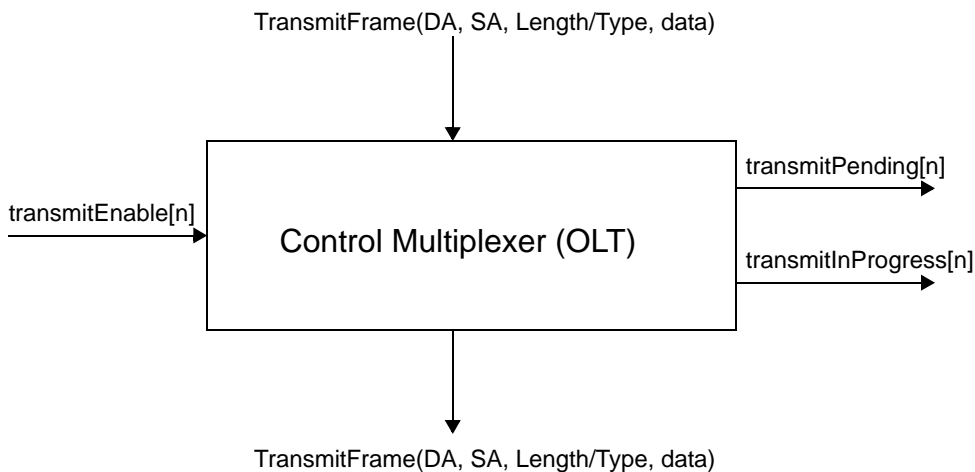

NOTE—TransmitFrame primitive may be issued from multiple MAC Control processing blocks.

**Figure 64-7—OLT Control Multiplexer Service Interfaces**

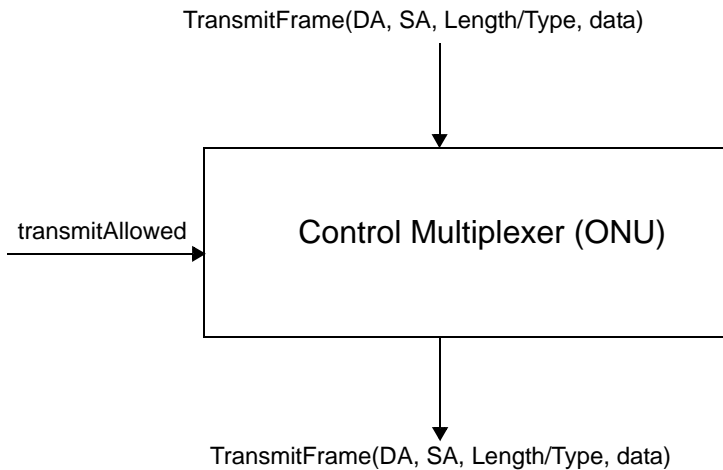

NOTE—TransmitFrame primitive may be issued from multiple MAC Control processing blocks.

**Figure 64-8—ONU Control Multiplexer Service Interfaces**

**64.2.2.1 Constants**

defaultOverhead

This constant holds the size of packet transmission overhead. This overhead is measured in the units of time\_quantum.

TYPE: integer

VALUE: 6

1  
2  
3  
4  
5  
6  
7  
8  
9  
10  
11  
12  
13  
14  
15  
16  
17  
18  
19  
20  
21  
22  
23  
24  
25  
26  
27  
28  
29  
30  
31  
32  
33  
34  
35  
36  
37  
38  
39  
40  
41  
42  
43  
44  
45  
46  
47  
48  
49  
50  
51  
52  
53  
54

1 guardThresholdOLT  
2 This constant holds the maximal amount of drift allowed for a timestamp received at the  
3 OLT. This value is measured in the units of time\_quantum.  
4 TYPE: integer  
5 VALUE: 12  
6 guardThresholdONU  
7 This constant holds the maximal amount of drift allowed for a timestamp received at the  
8 ONU. This value is measured in the units of time\_quantum.  
9 TYPE: integer  
10 VALUE: 8  
11 MAC\_Control\_type  
12 The value of the Length/Type field as defined in Clause 31.4.1.3.  
13 TYPE: integer  
14 VALUE: 0x8808  
15 tailGuard  
16 This constant holds the value used to reserve space at the end of the upstream transmission  
17 at the ONU in addition to the size of last MAC service data unit (m\_sdu) in the units of  
18 octets.  
19 Space is reserved for the MAC overheads including: preamble, SFD, DA, SA, Length/  
20 Type, FCS, and the End of Packet Delimiter (EPD). The sizes of the above listed MAC  
21 overhead items are described in Clause 3.1.1. The size of the EPD is described in Clause  
22 36.2.4.14.  
23 TYPE: integer  
24 VALUE: @@TBD@@  
25 time\_quantum  
26 The unit of time\_quantum is used by all mechanisms synchronized to the advancement of  
27 the localTime variable. All variables that represent counters and time intervals are defined  
28 using time\_quantum. Each time\_quantum is equal to 16 ns.  
29 TYPE: integer  
30 VALUE: 16

#### 64.2.2.2 Counters

31 localTime  
32 This variable holds the value of the local timer used to control MPCP operation. This  
33 variable is advanced by a timer at 62.5MHz, and counts in time\_quanta. At the OLT the  
34 counter shall track the transmit clock, while at the ONU the counter shall track the receive  
35 clock. For accuracy of receive clock see 65.3.1.2. It is reloaded with the received timestamp  
36 value (from the OLT) by the Control Parser (see Figure 64–11). Changing the value of this  
37 variable while running using Layer Management is highly undesirable and is unspecified.  
38 TYPE: 32-bit unsigned

#### 64.2.2.3 Variables

39 BEGIN  
40 This variable is used when initiating operation of the functional block state machine. It is  
41 set to true following initialization and every reset.  
42 TYPE: boolean  
43 data\_rx  
44 This variable represents a 0-based bit array corresponding to the payload of a received  
45 MPCPDU. This variable is used to parse incoming MPCPDU frames.  
46 TYPE: bit array  
47 data\_tx

	This variable represents a 0-based bit array corresponding to the payload of an MPCPDU being transmitted. This variable is used to access payload of outgoing MPCPDU frames, for example to set the timestamp value.	1
	TYPE: bit array	2
fecEnabled	This variable represents whether the FEC function is enabled. If FEC function is enabled, this variable equals true, otherwise it equals false.	3
	TYPE: boolean	4
newRTT	This variable temporary holds a newly-measured Round Trip Time to the ONU. The new RTT value is represented in the units of time_quanta.	5
	TYPE: 16-bit unsigned	6
nextTxTime	This variable represents a total transmission time of next packet and is used to check whether the next packet fits in the remainder of ONU's transmission window. The value of nextTxTime includes packet transmission time, tailGuard defined in 64.2.2.1, and FEC parity data overhead, if FEC is enabled. This variable is measured in the units of time_quanta.	7
	TYPE: 16-bit unsigned	8
opcode_rx	This variable holds an opcode of the last received MPCPDU.	9
	TYPE: 16-bit unsigned	10
opcode_tx	This variable holds an opcode of an outgoing MPCPDU.	11
	TYPE: 16-bit unsigned	12
packet_initiate_delay	This variable is used to set the time-out interval for packet_initiate_timer defined in 64.2.2.5. The packet_initiate_delay value is represented in the units of time_quanta.	13
	TYPE: 16-bit unsigned	14
RTT	This variable holds the measured Round Trip Time to the ONU. The RTT value is represented in the units of time_quanta.	15
	TYPE: 16-bit unsigned	16
stopTime	This variable holds the value of the localTime counter corresponding to the end of the nearest grant. This value is set by the Gate Processing function as described in 64.3.5.	17
	TYPE: 32-bit unsigned	18
timestamp	This variable holds the value of timestamp of the last received MPCPDU frame.	19
	TYPE: 32-bit unsigned	20
timestampDrift	This variable is used to indicate whether an error is signaled as a result of uncorrectable timestamp drift.	21
	TYPE: boolean	22
transmitAllowed	This variable is used to control PDU transmission at the ONU. It is set to true when the transmit path is enabled, and is set to false when the transmit path is being shut down. transmitAllowed changes its value according to the state of the Gate Processing functional block.	23
	TYPE: boolean	24

1 transmitEnable[j]  
2 These variables are used to control the transmit path in a Multipoint MAC Control instance  
3 at the OLT. Setting them to on indicates that the selected instance is permitted to transmit a  
4 frame. Setting it to off inhibits the transmission of frames in the selected instance. Only one  
5 of transmitEnable[j] should be set to on at a time.  
6 TYPE: boolean  
7  
8 transmitInProgress[j]  
9 This variable indicates that the Multipoint MAC Control instance *j* is in a process of  
10 transmitting a frame.  
11 TYPE: boolean  
12  
13 transmitPending[j]  
14 This variable indicates that the Multipoint MAC Control instance *j* is ready to transmit a  
15 frame.  
16 TYPE: boolean

#### 64.2.2.4 Functions

17  
18 abs(n)  
19 This function returns the absolute value of the parameter *n*.  
20  
21 Opcode-specific function(opcode)  
22 Functions exported from opcode specific blocks that are invoked on the arrival of a MAC  
23 Control message of the appropriate opcode.  
24  
25 FEC\_Overhead(length)  
26 This function calculates the size of additional overhead to be added by the FEC encoder  
27 while encoding a frame of size length. This function is further defined in 64A.2.1.1 and  
28 64B.2.2.1 for 1000 Mb/s and 10 Gb/s EPONs, respectively.  
29  
30 ReceiveFrame(DA, SA, Length/Type, data)  
31 The MAC Sublayer function that is called to receive a frame with the specified parameters.  
32  
33 select  
34 This function selects the next Multipoint MAC Control instance allowed to initiate  
35 transmission of a frame. The function returns an index to the transmitPending array for  
36 which the value is not false. The selection criteria in the presence of multiple active  
37 elements in the list is implementation dependent.  
38  
39 SelectFrame()  
40 This function enables the interface, which has a pending frame. If multiple interfaces have  
41 frames waiting at the same time, only one interface will be enabled. The selection criteria  
42 is not specified, except for the case when some of the pending frames have Length/Type =  
43 MAC\_Control. In this case, one of the interfaces with a pending MAC Control frame shall  
44 be enabled.  
45  
46 sizeof(sdu)  
47 This function returns the size of the sdu in octets.  
48  
49 tqSize  
50 This function returns the size of 1 time\_quantum in octet transmission times. This function  
51 is further defined in 64A.2.1.1 and 64B.2.2.1 for 1000 Mb/s and 10 Gb/s EPONs,  
52 respectively.  
53  
54

transmissionPending()

This function returns true if any of the Multipoint MAC Control instances has a frame waiting to be transmitted. The function can be represented as

transmissionPending() = transmitPending[0] +  
transmitPending[1] +  
... +  
transmitPending[n-1]

where n is the total number of Multipoint MAC Control instances.

TransmitFrame(DA, SA, Length/Type, data)

The MAC Sublayer function that is called to transmit a frame with the specified parameters.

#### 64.2.2.5 Timers

packet\_initiate\_timer

This timer is used to delay frame transmission from MAC Control to avoid variable MAC delay while MAC enforces IPG after a previous frame. In addition, when FEC is enabled, this timer increases interframe spacing just enough to accommodate the extra parity data to be added by the FEC encoder.

#### 64.2.2.6 Messages

MA\_DATA.indication(DA, SA, m\_sdu, receiveStatus)

The service primitive is defined in 2.3.2.

#### 64.2.2.7 State Diagrams

The Multipoint transmission control function in the OLT shall implement state diagram shown in Figure 64–9. Control parser function in the OLT shall implement state diagram shown in Figure 64–10. Control parser function in the ONU shall implement state diagram shown in Figure 64–11. Control multiplexer function in the OLT shall implement state diagram shown in Figure 64–12. Control multiplexer function in the ONU shall implement state diagram shown in Figure 64–13.

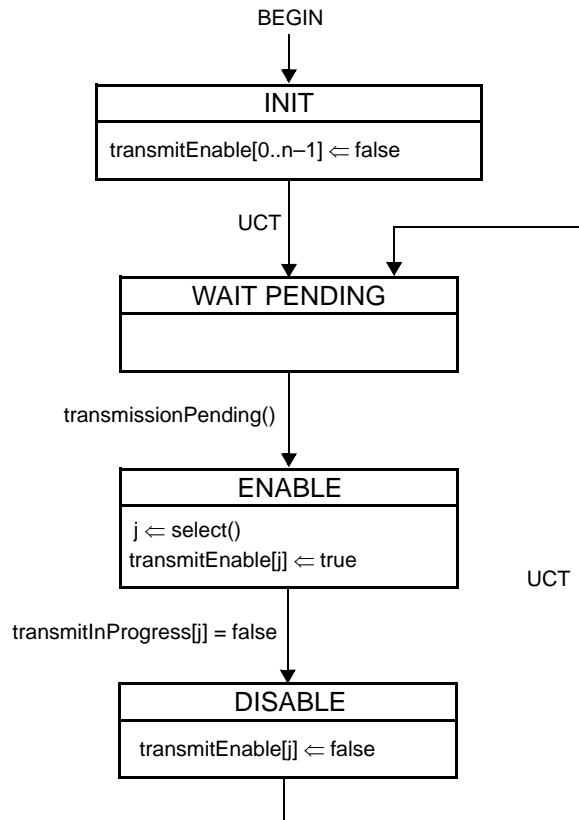
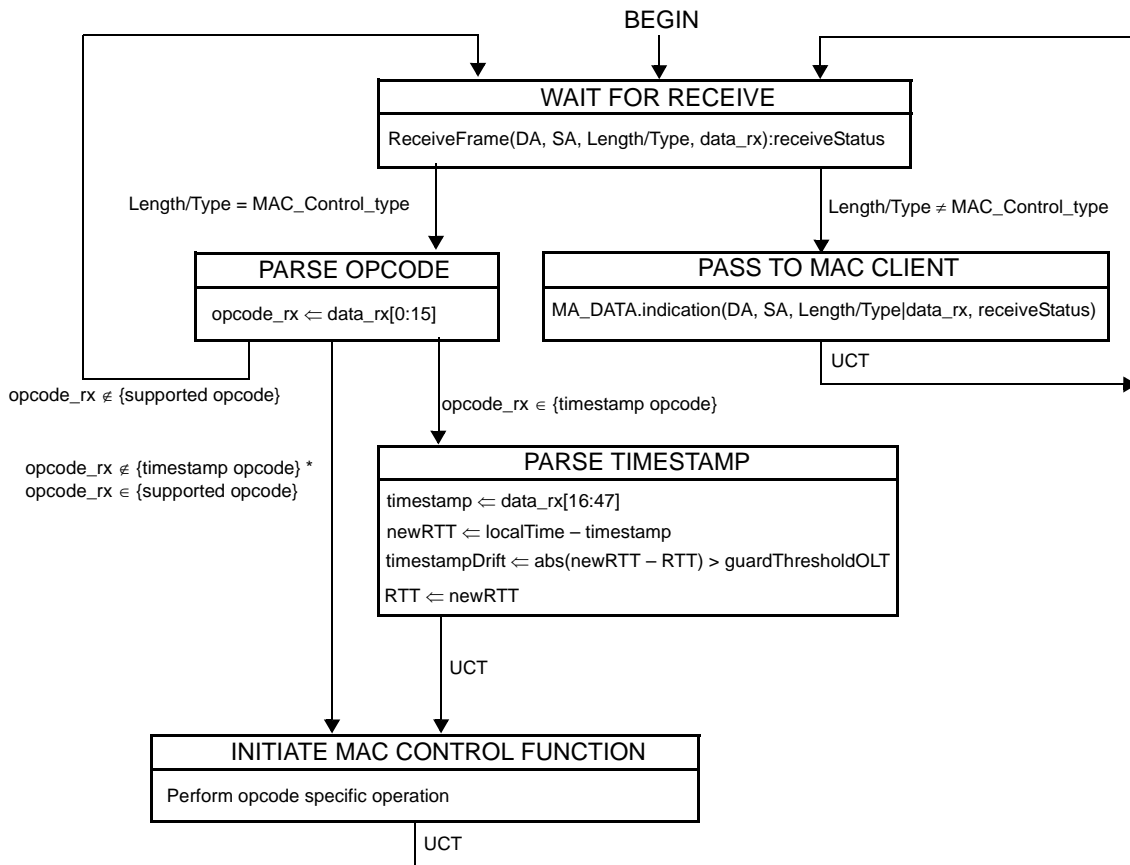

Figure 64–9—OLT Multipoint Transmission Control state diagram



NOTE—The opcode-specific operation is launched as a parallel process by the MAC Control sublayer, and not as a synchronous function. Progress of the generic MAC Control Receive state machine (as shown in this figure) is not implicitly impeded by the launching of the opcode specific function.

Refer to Annex 31A for list of supported opcodes and timestamp opcodes.

**Figure 64–10—OLT Control Parser state diagram**

1  
2  
3  
4  
5  
6  
7  
8  
9  
10  
11  
12  
13  
14  
15  
16  
17  
18  
19  
20  
21  
22  
23  
24  
25  
26  
27  
28  
29  
30  
31  
32  
33  
34  
35  
36  
37  
38  
39  
40  
41  
42  
43  
44  
45  
46  
47  
48  
49  
50  
51  
52  
53  
54

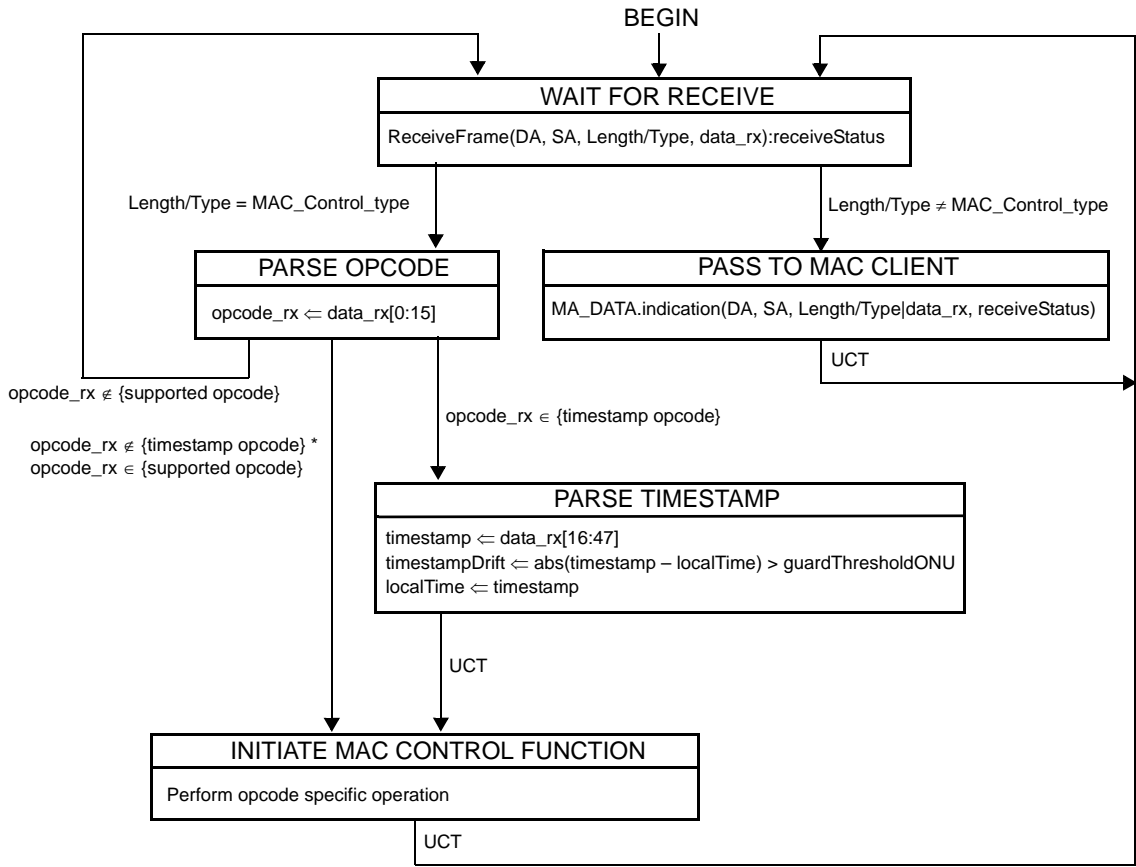

NOTE— The opcode-specific operation is launched as a parallel process by the MAC Control sublayer, and not as a synchronous function. Progress of the generic MAC Control Receive state machine (as shown in this figure) is not implicitly impeded by the launching of the opcode specific function.

Refer to Annex 31A for list of supported opcodes and timestamp opcodes.

**Figure 64–11—ONU Control Parser state diagram**



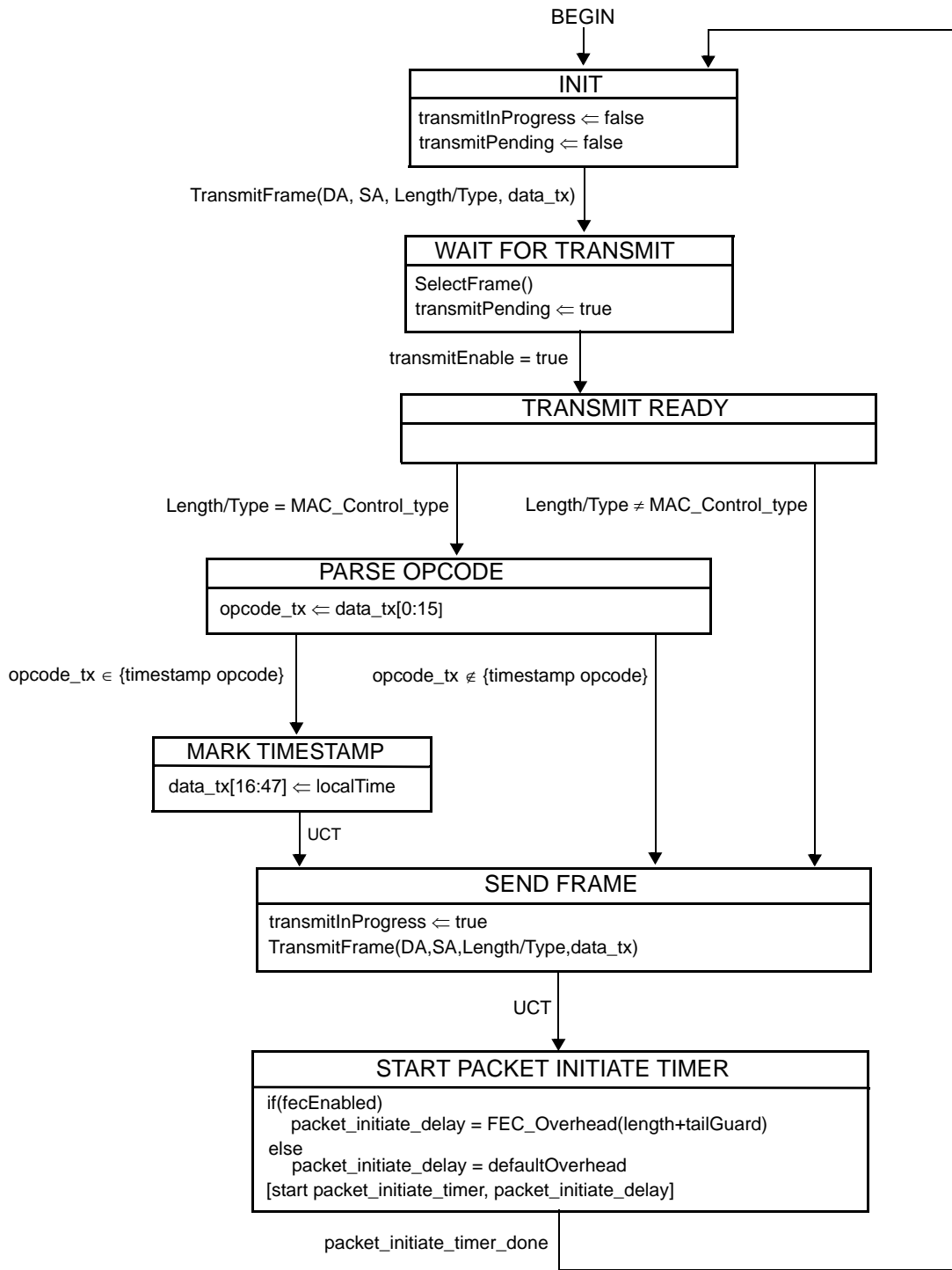

Figure 64–12—OLT Control Multiplexer state diagram

1  
2  
3  
4  
5  
6  
7  
8  
9  
10  
11  
12  
13  
14  
15  
16  
17  
18  
19  
20  
21  
22  
23  
24  
25  
26  
27  
28  
29  
30  
31  
32  
33  
34  
35  
36  
37  
38  
39  
40  
41  
42  
43  
44  
45  
46  
47  
48  
49  
50  
51  
52  
53  
54

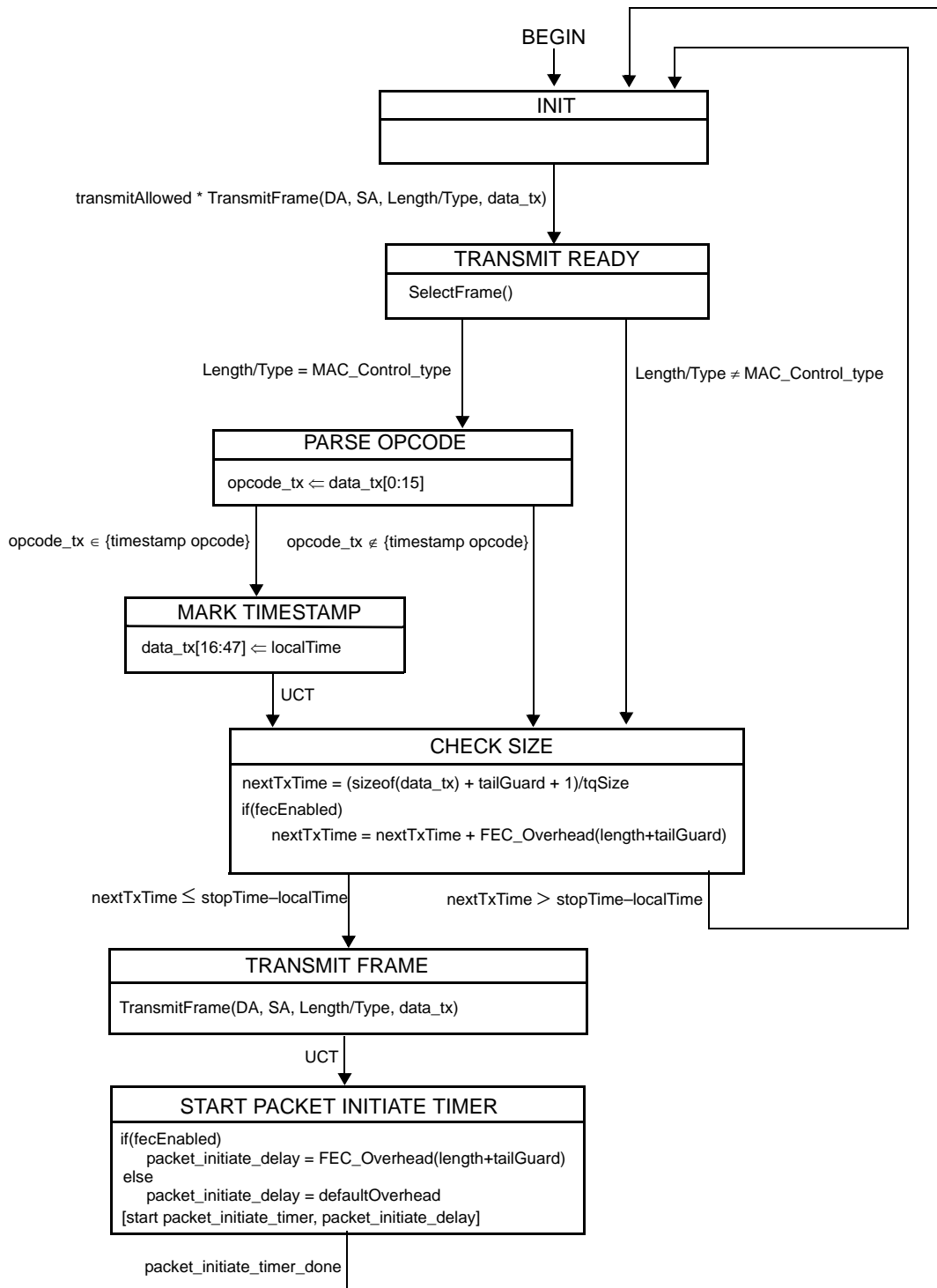

Figure 64-13—ONU Control Multiplexer state diagram

## 64.3 Multipoint Control Protocol (MPCP)

As depicted in Figure 64–3, the Multipoint MAC Control functional block comprises the following functions:

- a) *Discovery Processing*. This block manages the discovery process, through which an ONU is discovered and registered with the network while compensating for RTT.
- b) *Report Processing*. This block manages the generation and collection of report messages, through which bandwidth requirements are sent upstream from the ONU to the OLT.
- c) *Gate Processing*. This block manages the generation and collection of gate messages, through which multiplexing of multiple transmitters is achieved.

As depicted in Figure 64–3, the layered system may instantiate multiple MAC entities, using a single physical layer. Each instantiated MAC communicates with an instance of the opcode specific functional blocks through the Multipoint MAC Control. In addition some global variables are shared across the multiple instances. Common state control is used to synchronize the multiple MACs using MPCP procedures. Operation of the common state control is generally considered outside the scope of this document.

### 64.3.1 Principles of Multipoint Control Protocol

Multipoint MAC Control enables a MAC Client to participate in a point-to-multipoint optical network by allowing it to transmit and receive frames as if it was connected to a dedicated link. In doing so, it employs the following principles and concepts:

- a) A MAC client transmits and receives frames through the Multipoint MAC Control sublayer.
- b) The Multipoint MAC Control decides when to allow a frame to be transmitted using the client interface Control Multiplexer.
- c) Given a transmission opportunity, the MAC Control may generate control frames that would be transmitted in advance of the MAC Client's frames, utilizing the inherent ability to provide higher priority transmission of MAC Control frames over MAC Client frames.
- d) Multiple MACs operate on a shared medium by allowing only a single MAC to transmit upstream at any given time across the network using a time-division multiple access (TDMA) method.
- e) Such gating of transmission is orchestrated through the Gate Processing function.
- f) New devices are discovered in the network and allowed transmission through the Discovery Processing function.
- g) Fine control of the network bandwidth distribution can be achieved using feedback mechanisms supported in the Report Processing function.
- h) The operation of P2MP network is asymmetrical, with the OLT assuming the role of master, and the ONU assuming the role of slave.

### 64.3.2 Compatibility considerations

#### 64.3.2.1 PAUSE operation

Even though MPCP is compatible with flow control, optional use of flow control may not be efficient in the case of large propagation delay. If flow control is implemented, then the timing constraints in Clause 31B supplement the constraints found at 64.3.2.4.

NOTE—MAC at an ONU can receive frames from unicast channel and SCB channel. If the SCB channel is used to broadcast data frames to multiple ONUs, the ONU's MAC may continue receiving data frames from SCB channel even after the ONU has issued a PAUSE request to its unicast remote-end.

### 64.3.2.2 Optional Shared LAN Emulation

By combining P2PE, suitable filtering rules at the ONU, and suitable filtering and forwarding rules at the OLT, it is possible to emulate an efficient shared LAN. Support for shared LAN emulation is optional, and requires an additional layer above the MAC, which is out of scope for this document. Thus, shared LAN emulation is introduced here for informational purposes only.

Specific behaviour of the filtering layer at the RS is specified in 65.1.3.3.2.

### 64.3.2.3 Multicast and single copy broadcast support

In the downstream direction, the PON is a broadcast medium. In order to make use of this capability for forwarding broadcast frames from the OLT to multiple recipients without frame duplication for each ONU, the SCB support is introduced.

The OLT has at least one MAC associated with every ONU. In addition, one more MAC instance at the OLT is marked as the SCB MAC. A SCB MAC handles all downstream broadcast traffic to ONUs, but is never used in the upstream direction for client traffic, except for client registration. This SCB MAC instance is associated with a unique LLID. The SCB MAC instance associated with the LLID 0x7FFF provides broadcast services for ONUs operating at 1000 Mb/s in the downstream direction. Optional higher layers may be implemented to perform selective broadcast of frames. Such layers may require additional MACs (multicast MACs) to be instantiated in the OLT for some or all ONUs increasing the total number of MACs beyond the number of ONUs + 1.

When connecting the SCB MAC instance to an 802.1D bridge port it is possible that loops may be formed due to the broadcast nature of the underlying link. Thus it is recommended that the said MAC instance is not connected to an 802.1D bridge port.

Configuration of SCB channels as well as filtering and marking of frames for support of SCB is defined in 65.1.3.3.2 for 1000 Mb/s EPON compliant Reconciliation Sublayers.

### 64.3.2.4 Delay requirements

The MPCP protocol relies on strict timing based on distribution of timestamps. A compliant implementation needs to guarantee a constant delay through the MAC and PHY in order to maintain the correctness of the timestamping mechanism. The actual delay is implementation dependent, however, a complying implementation shall maintain a delay variation of no more than 1 time\_quantum through the implemented MAC stack.

The OLT shall not grant less than 1024 time\_quanta into the future, in order to allow the ONU processing time when it receives a gate message. The ONU shall process all messages in less than this period. The OLT shall not issue more than one message every 1024 time\_quanta to a single ONU. The unit of time\_quantum is defined as 16 ns.

### 64.3.3 Discovery Processing

Discovery is the process whereby newly connected or off-line ONUs are provided access to the PON. The process is driven by the OLT, which periodically makes available Discovery Time Windows during which off-line ONUs are given the opportunity to make themselves known to the OLT. The periodicity of these windows is unspecified and left up to the implementor. The OLT signifies that a discovery period is occurring by broadcasting a discovery GATE MPCPDU, which includes the starting time and length of the discovery window, along with the Discovery Information flag field, as defined in 64.3.6.1. With the appropriate settings of individual flags contained in this 16 bit wide field, the OLT notifies all the ONUs

about its upstream and downstream channel transmission capabilities. Note that the OLT may simultaneously support more than one data rate in the given transmission direction.

Off-line ONUs, upon receiving a Discovery GATE MPCPDU, wait for the period to begin and then transmit a REGISTER\_REQ MPCPDU to the OLT. Discovery windows are unique in that they are the only times where multiple ONUs can access the PON simultaneously, and transmission overlap can occur. In order to reduce transmission overlaps, a contention algorithm is used by all ONUs. Measures are taken to reduce the probability for overlaps by artificially simulating a random distribution of distances from the OLT. Each ONU shall wait a random amount of time before transmitting the REGISTER\_REQ MPCPDU that is shorter than the length of the discovery time window. It should be noted that multiple valid REGISTER\_REQ MPCPDUs can be received by the OLT during a single discovery time period. Included in the REGISTER\_REQ MPCPDU is the ONU's MAC address and number of maximum pending grants. Additionally, a registering ONU notifies the OLT on its transmission capabilities in the upstream and downstream channels by setting appropriately the flags in the Discovery Information field, as specified in 64.3.6.3.

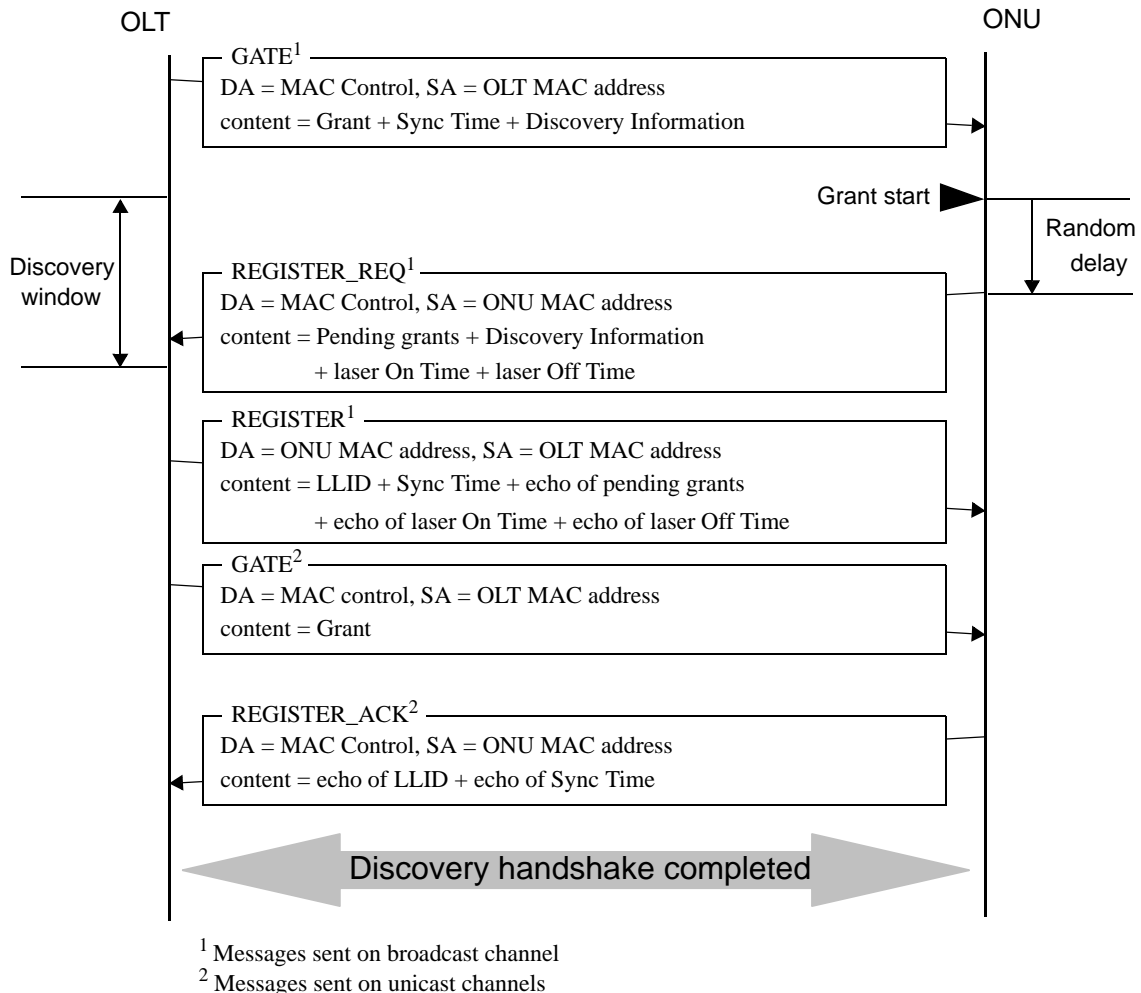

**Figure 64-14—Discovery Handshake Message Exchange**

Note that even though a compliant ONU is not prohibited from supporting more than one data rate in any transmission channel, it is expected that a single supported data rate for upstream and downstream channel will be indicated in the Discovery Information field. Moreover, in order to assure maximum utilization of the upstream channel and to decrease the required size of the guard band between individual data bursts, the registering ONU shall notify the OLT on the laser on / off times, by setting appropriate values in the Laser On Time and Laser Off Time fields, where both values are expressed in the units of time\_quanta.

Upon receipt of a valid REGISTER\_REQ MPCPDU, the OLT registers the ONU, allocating and assigning new port identities (LLIDs), and bonding corresponding MACs to the LLIDs.

The next step in the process is for the OLT to transmit a REGISTER MPCPDU to the newly discovered ONU, which contains the ONU's LLID, and the OLT's required synchronization time. Also, the OLT echoes the maximum number of pending grants, laser on time and laser off time. Note that the echoed parameter values i.e. required OLT synchronization time and laser on/off times are delivered to the registering ONU for confirmation purposes only and their utilization is not prescribed in this specification.

The OLT now has enough information to schedule the ONU for access to the PON and transmits a standard GATE message allowing the ONU to transmit a REGISTER\_ACK. Upon receipt of the REGISTER\_ACK, the discovery process for that ONU is complete, the ONU is registered and normal message traffic can begin. It is the responsibility of Layer Management to perform the MAC bonding, and start transmission from/to the newly registered ONU. The discovery message exchange is illustrated in Figure 64–14.

There may exist situations when the OLT requires that an ONU go through the discovery sequence again and reregister. Similarly, there may be situations where an ONU needs to inform the OLT of its desire to deregister. The ONU can then reregister by going through the discovery sequence. For the OLT, the REGISTER message may indicate a value, Reregister or Deregister, that if either is specified will force the receiving ONU into reregistering. For the ONU, the REGISTER\_REQ message contains the Deregister bit that signifies to the OLT that this ONU should be deregistered.

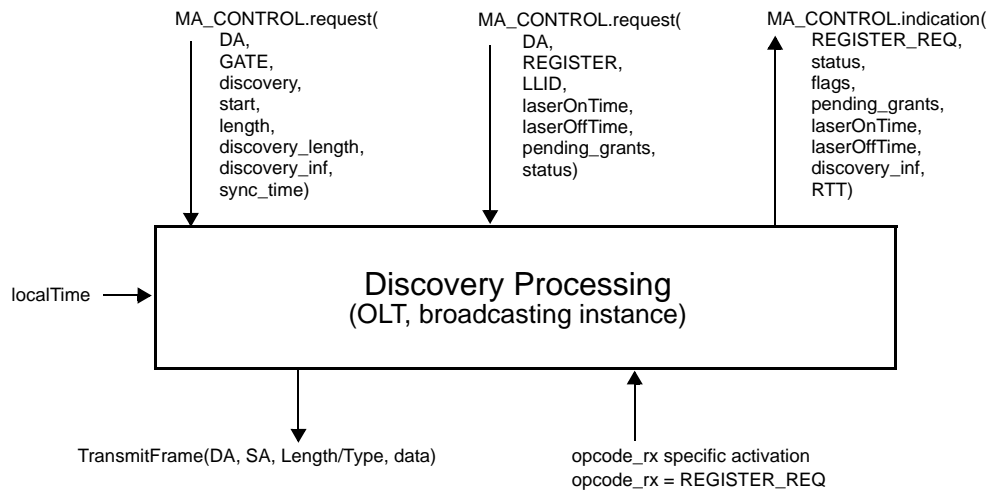

**Figure 64–15—Discovery Processing Service Interfaces (OLT, broadcasting instance)**

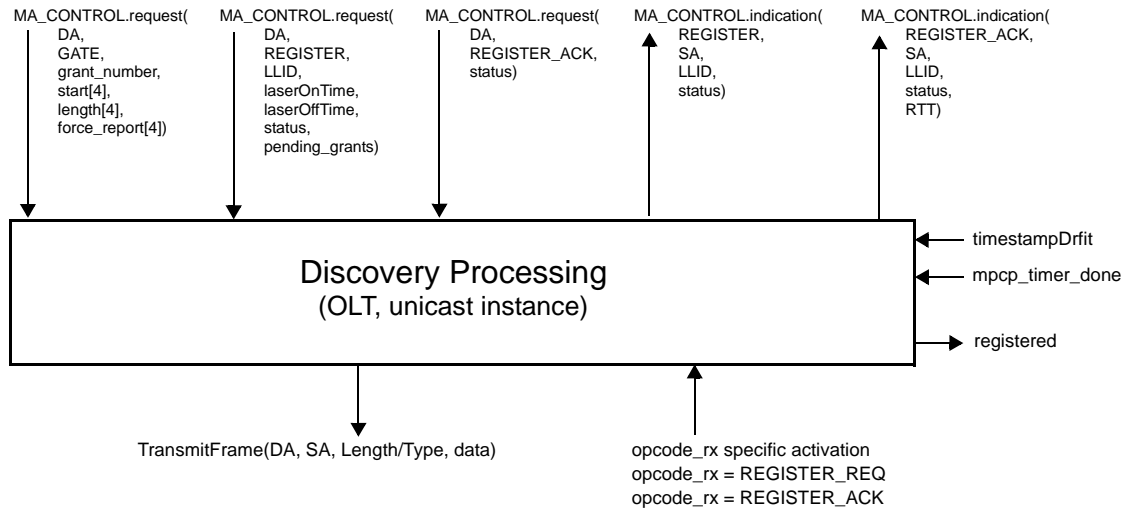

**Figure 64-16—Discovery Processing Service Interfaces (OLT, unicast instance)**

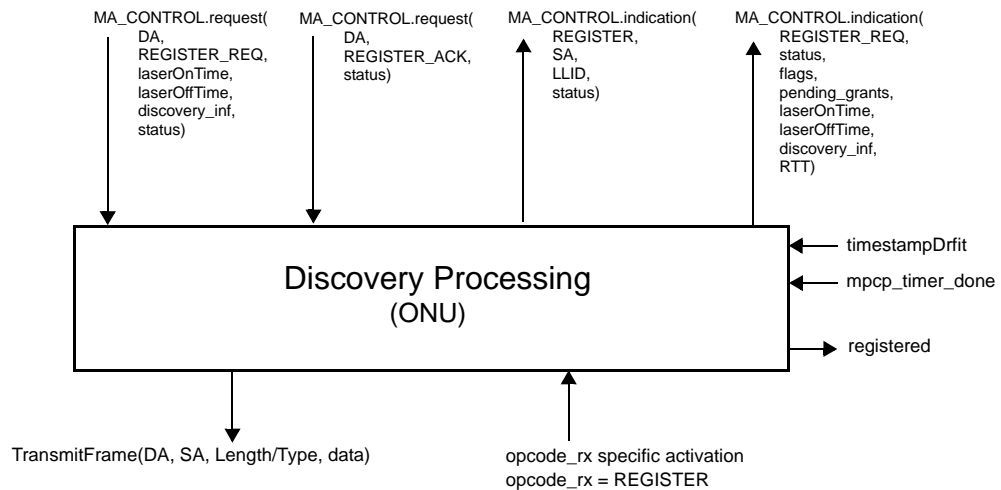

**Figure 64-17—Discovery Processing Service Interfaces (ONU)**

### 64.3.3.1 Constants

No constants defined.

### 64.3.3.2 Variables

BEGIN

This variable is defined in 64.2.2.3.

data\_rx

This variable is defined in 64.2.2.3.

1  
2  
3  
4  
5  
6  
7  
8  
9  
10  
11  
12  
13  
14  
15  
16  
17  
18  
19  
20  
21  
22  
23  
24  
25  
26  
27  
28  
29  
30  
31  
32  
33  
34  
35  
36  
37  
38  
39  
40  
41  
42  
43  
44  
45  
46  
47  
48  
49  
50  
51  
52  
53  
54

1 data\_tx  
2 This variable is defined in 64.2.2.3.  
3  
4 discovery\_inf  
5 This variable holds the contents of the Discovery Field, as specified in 64.3.6.1 for GATE  
6 MPCPDU and 64.3.6.3 for REGISTER\_REQ MPCPDU.  
7 TYPE: 16-bit unsigned  
8  
9 grantEndTime  
10 This variable holds the time at which the OLT expects the ONU grant to complete. Failure  
11 of a REGISTER\_ACK message from an ONU to arrive at the OLT before grantEndTime  
12 is a fatal error in the discovery process, and causes registration to fail for the specified  
13 ONU, who may then retry to register. The value of grantEndTime is measured in units of  
14 time\_quantum.  
15 TYPE: 32-bit unsigned  
16  
17 insideDiscoveryWindow  
18 This variable holds the current status of the discovery window. It is set to true when the  
19 discovery window opens, and is set to false when the discovery window closes.  
20 TYPE: boolean  
21  
22 laserOffTime  
23 This variable holds the time required to terminate the laser. It counts in time\_quanta units  
24 the time period required for turning off the PMD, as specified in 60.7.13.1.  
25 TYPE: 8-bit unsigned  
26  
27 laserOnTime  
28 This variable holds the time required to initiate the PMD. It counts in time\_quanta units the  
29 time period required for turning on the PMD, as specified in 60.7.13.1.  
30 TYPE: 8-bit unsigned  
31  
32 localTime  
33 This variable is defined in 64.2.2.2.  
34  
35 opcode\_rx  
36 This variable is defined in 64.2.2.3.  
37  
38 opcode\_tx  
39 This variable is defined in 64.2.2.3.  
40  
41 pendingGrants  
42 This variable holds the maximum number of pending grants that an ONU is able to queue.  
43 TYPE: 16-bit unsigned  
44  
45 registered  
46 This variable holds the current result of the Discovery Process. It is set to true once the  
47 discovery process is complete and registration is acknowledged.  
48 TYPE: boolean  
49  
50 syncTime  
51 This variable holds the time required to stabilize the receiver at the OLT. It counts  
52 time\_quanta units from the point where transmission output is stable to the point where  
53 synchronization has been achieved. The value of syncTime includes gain adjustment  
54 interval ( $T_{\text{receiver\_settling}}$ ), clock synchronization interval ( $T_{\text{cdr}}$ ), and code-group alignment  
interval ( $T_{\text{code\_group\_align}}$ ), as specified in 60.7.13.2. The OLT conveys the value of  
syncTime to ONUs in Discovery GATE and REGISTER MPCPDUs. During the  
synchronization time, a prescribed pattern must be transmitted by the ONU, as defined in  
64A.2.2.1 and 64B.2.3.1 for 1000 Mb/s and 10 Gb/s EPONs, respectively.  
TYPE: 16-bit unsigned  
timestampDrift  
This variable is defined in 64.2.2.3.



### 64.3.3.3 Functions

ReceiveFrame(DA, SA, Length/Type, data)

This function is defined in 64.2.2.4.

TransmitFrame(DA, SA, Length/Type, data)

This function is defined in 64.2.2.4.

GetLaserTime(data)

This function is called to retrieve the appropriate values of the laserOnTime and laserOffTime variables for 1000 Mb/s and 10 Gb/s EPONs. This function is further defined in 64A.2.2.2 and 64B.2.3.2 for 1000 Mb/s and 10 Gb/s EPONs, respectively.

### 64.3.3.4 Timers

discovery\_window\_size\_timer

This timer is used to wait for the event signaling the end of the discovery window.

VALUE: The timer value is set dynamically based on the parameters received in a DISCOVERY GATE message.

mpcp\_timer

This timer is used to measure the arrival rate of MPCP frames in the link. Failure to receive frames is considered a fatal fault and leads to deregistration.

### 64.3.3.5 Messages

MA\_CONTROL.request(DA, GATE, discovery, start, length, discovery\_length, discovery\_inf, sync\_time)

The service primitive used by the MAC Control client at the OLT to initiate the Discovery Process. This primitive takes the following parameters:

DA:	multicast or unicast MAC address.
GATE:	opcode for GATE MPCPDU as defined in Table 31A–1.
discovery:	flag specifying that the given GATE message is to be used for discovery only.
start:	start time of the discovery window.
length:	length of the grant given for discovery.
discovery_length:	length of the discovery window process.
discovery_inf:	This parameter represents the Discovery Information field in GATE MPCPDU as specified in 64.3.6.1. This parameter has the default value of 0.
sync_time:	the time interval required to stabilize the receiver at the OLT.

MA\_CONTROL.request(DA, GATE, grant\_number, start[4], length[4], force\_report[4])

This service primitive is used by the MAC Control client at the OLT to issue the GATE message to an ONU. This primitive takes the following parameters:

DA:	multicast MAC Control address as defined in Annex 31B.
GATE:	opcode for GATE MPCPDU as defined in Table 31A–1.
grant_number:	number of grants issued with this GATE message. The number of grants ranges from 0 to 4.
start[4]:	start times of the individual grants. Only the first grant_number elements of the array are used.
length[4]:	lengths of the individual grants. Only the first grant_number elements of the array are used.

1 force\_report[4]: flags indicating whether a REPORT message should be  
2 generated in the corresponding grant. Only the first  
3 grant\_number elements of the array are used.  
4

5 MA\_CONTROL.request(DA, REGISTER\_REQ, laserOnTime, laserOffTime, discovery\_inf,  
6 status)

7 The service primitive used by a client at the ONU to request the Discovery Process to  
8 perform a registration. This primitive takes the following parameters:

9 DA: multicast MAC Control address as defined in Annex 31B.  
10 REGISTER\_REQ: opcode for REGISTER\_REQ MPCPDU as defined in  
11 Table 31A-1.  
12 laserOnTime: This parameter holds the laserOnTime value, expressed in  
13 time\_quanta units, as reported by MAC client and  
14 specified in 64.3.6.3. This parameter has the default value  
15 of 0.  
16 laserOffTime: This parameter holds the laserOffTime value, expressed in  
17 time\_quanta units, as reported by MAC client and  
18 specified in 64.3.6.3. This parameter has the default value  
19 of 0.  
20 discovery\_inf: This parameter represents the Discovery Information field,  
21 as specified in 64.3.6.3. This parameter has the default  
22 value of 0.  
23 status: This parameter takes on the indication supplied by the  
24 flags field in the REGISTER\_REQ MPCPDU as defined  
25 in Table 64-3.  
26

27 MA\_CONTROL.indication(REGISTER\_REQ, status, flags, pending\_grants, laserOnTime,  
28 laserOffTime, discovery\_inf, RTT)

29 The service primitive issued by the Discovery Process to notify the client and Layer  
30 Management that the registration process is in progress. This primitive takes the following  
31 parameters:

32 REGISTER\_REQ: opcode for REGISTER\_REQ MPCPDU as defined in  
33 Table 31A-1.  
34 status: This parameter holds the values incoming or retry. Value  
35 incoming is used at the OLT to signal that a  
36 REGISTER\_REQ message was received successfully. The  
37 value retry is used at the ONU to signal to the client that a  
38 registration attempt failed and will be repeated.  
39 flags: This parameter holds the contents of the flags field in the  
40 REGISTER\_REQ message. This parameter holds a valid  
41 value only when the primitive is generated by the  
42 Discovery Process in the OLT.  
43 pending\_grants: This parameters holds the contents of the pending\_grants  
44 field in the REGISTER\_REQ message. This parameter  
45 holds a valid value only when the primitive is generated by  
46 the Discovery Process in the OLT.  
47 laserOnTime: This parameter holds the laserOnTime value, expressed in  
48 time\_quanta units, as reported by the registering ONU in  
49 the REGISTER\_REQ MPCPDU. This parameter has the  
50 default value of 0 and is only valid when the primitive is  
51 generated by the Discovery process in the OLT  
52  
53  
54

laserOffTime:	This parameter holds the laserOffTime value, expressed in time_quanta units, as reported by the registering ONU in the REGISTER_REQ MPCPDU. This parameter has the default value of 0 and is only valid when the primitive is generated by the Discovery process in the OLT.	1 2 3 4 5
discovery_inf:	This parameter represents the Discovery Information field in REGISTER_REQ MPCPDU as specified in 64.3.6.3. This parameter has the default value of 0 and is only valid when the primitive is generated by the Discovery process in the OLT.	6 7 8 9 10
RTT:	The measured round trip time to/from the ONU is returned in this parameter. RTT is stated in time_quanta units. This parameter holds a valid value only when the primitive is generated by the Discovery Process in the OLT.	11 12 13 14 15
<b>MA_CONTROL.request(DA, REGISTER, LLID, laserOnTime, laserOffTime, status, pending_grants)</b>		
The service primitive used by the MAC Control client at the OLT to initiate acceptance of an ONU. This primitive takes the following parameters:		
DA:	Unicast MAC address or multicast MAC Control address as defined in Annex 31B.	16 17 18 19 20 21
REGISTER:	opcode for REGISTER MPCPDU as defined in Table 31A-1.	22 23
LLID:	This parameter holds the logical link identification number assigned by the MAC Control client.	24 25
laserOnTime:	This parameter echoes back the laserOnTime field that was previously received in the REGISTER_REQ MPCPDU from the same MAC. This parameter has the default value of 0.	26 27 28 29
laserOffTime:	This parameter echoes back the laserOffTime field that was previously received in the REGISTER_REQ MPCPDU from the same MAC. This parameter has the default value of 0.	30 31 32 33
status:	This parameter takes on the indication supplied by the flags field in the REGISTER MPCPDU as defined in Table 64-4.	34 35 36
pending_grants:	This parameters echoes back the pending_grants field that was previously received in the REGISTER_REQ MPCPDU.	37 38 39 40
<b>MA_CONTROL.indication(REGISTER, SA, LLID, status)</b>		
This service primitive is issued by the Discovery Process at the OLT or an ONU to notify the MAC Control client and Layer Management of the result of the change in registration status. This primitive takes the following parameters:		
REGISTER:	opcode for REGISTER MPCPDU as defined in Table 31A-1.	41 42 43 44 45 46
SA	This parameter represents is the MAC address of the OLT.	47
LLID	This parameter holds the logical link identification number assigned by the MAC Control client.	48 49
status	This parameter holds the value of accepted/denied/deregistered/reregistered.	50 51 52 53 54

1 MA\_CONTROL.request(DA, REGISTER\_ACK, status)

2 This service primitive is issued by the MAC Control clients at the ONU and the OLT to  
3 acknowledge the registration. This primitive takes the following parameters:

- 4 DA: multicast MAC Control address as defined in Annex 31B.  
5 REGISTER\_ACK: opcode for REGISTER\_ACK MPCPDU as defined in  
6 Table 31A-1.  
7 status: This parameter takes on the indication supplied by the  
8 flags field in the REGISTER MPCPDU as defined in Table  
9 64-5.

10 MA\_CONTROL.indication(REGISTER\_ACK, SA, LLID, status, RTT)

11 This service primitive is issued by the Discovery Process at the OLT to notify the client and  
12 Layer Management that the registration process has completed. This primitive takes the  
13 following parameters:

- 14 REGISTER\_ACK: opcode for REGISTER\_ACK MPCPDU as defined in  
15 Table 31A-1.  
16 SA This parameter represents the MAC address of the  
17 reciprocating device (ONU address at the OLT, and OLT  
18 address at the ONU).  
19 LLID This parameter holds the logical link identification number  
20 assigned by the MAC Control client.  
21 status This parameter holds the value of accepted/denied/reset/  
22 deregistered.  
23 RTT The measured round trip time to/from the ONU is returned  
24 in this parameter. RTT is stated in time\_quanta units. This  
25 parameter holds a valid value only when the invoking  
26 Discovery Process is in the OLT  
27

28 Opcode-specific function(opcode)

29 Functions exported from opcode specific blocks that are invoked on the arrival of a MAC  
30 Control message of the appropriate opcode.  
31  
32

33 **64.3.3.6 State Diagram**

34  
35 Discovery process in the OLT shall implement the discovery window setup state diagram shown in  
36 Figure 64-18, request processing state diagram as shown in Figure 64-19, register processing state diagram  
37 as shown in Figure 64-20, and final registration state diagram as shown in Figure 64-21. The discovery  
38 process in the ONU shall implement registration state diagram as shown in Figure 64-22.  
39

40 Instantiation of state machines as described in Figure 64-18, Figure 64-19, and Figure 64-20 is performed  
41 only at the Multipoint MAC Control instances attached to the appropriate broadcast LLID(s) (0x7FFF and/  
42 or 0x7FFE for 1000 Mb/s and 10 Gb/s EPON, respectively). Instantiation of state machines as described in  
43 Figure 64-21 and Figure 64-22 is performed for every Multipoint MAC Control instance, except the  
44 instance attached to the broadcast channel.  
45  
46  
47  
48  
49  
50  
51  
52  
53  
54

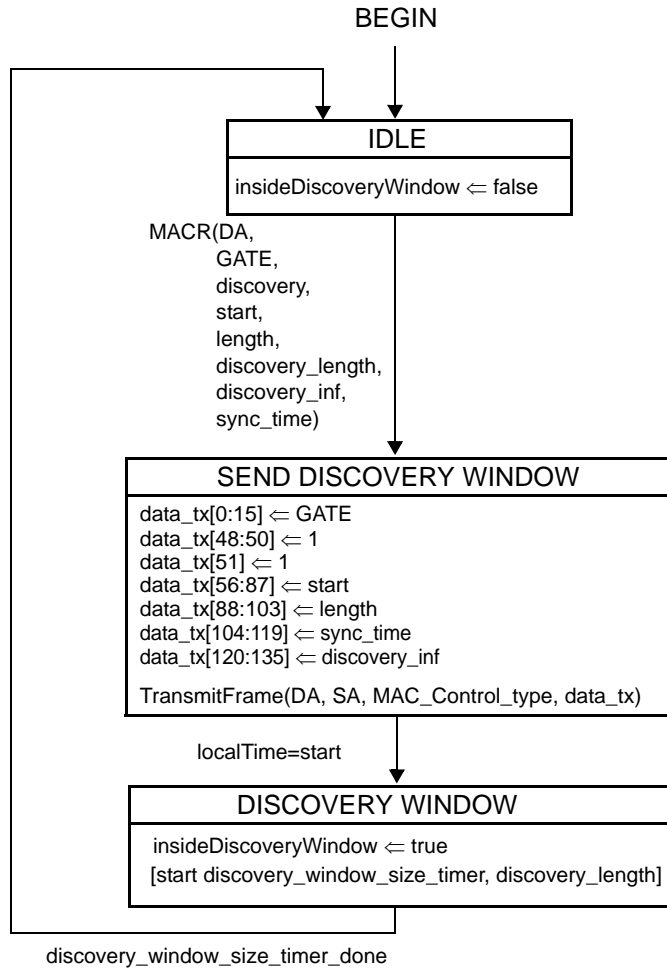

Figure 64–18—Discovery Processing OLT Window Setup State Diagram

1  
2  
3  
4  
5  
6  
7  
8  
9  
10  
11  
12  
13  
14  
15  
16  
17  
18  
19  
20  
21  
22  
23  
24  
25  
26  
27  
28  
29  
30  
31  
32  
33  
34  
35  
36  
37  
38  
39  
40  
41  
42  
43  
44  
45  
46  
47  
48  
49  
50  
51  
52  
53  
54

1  
2  
3  
4  
5  
6  
7  
8  
9  
10  
11  
12  
13  
14  
15  
16  
17  
18  
19  
20  
21  
22  
23  
24  
25  
26  
27  
28  
29  
30  
31  
32  
33  
34  
35  
36  
37  
38  
39  
40  
41  
42  
43  
44  
45  
46  
47  
48  
49  
50  
51  
52  
53  
54

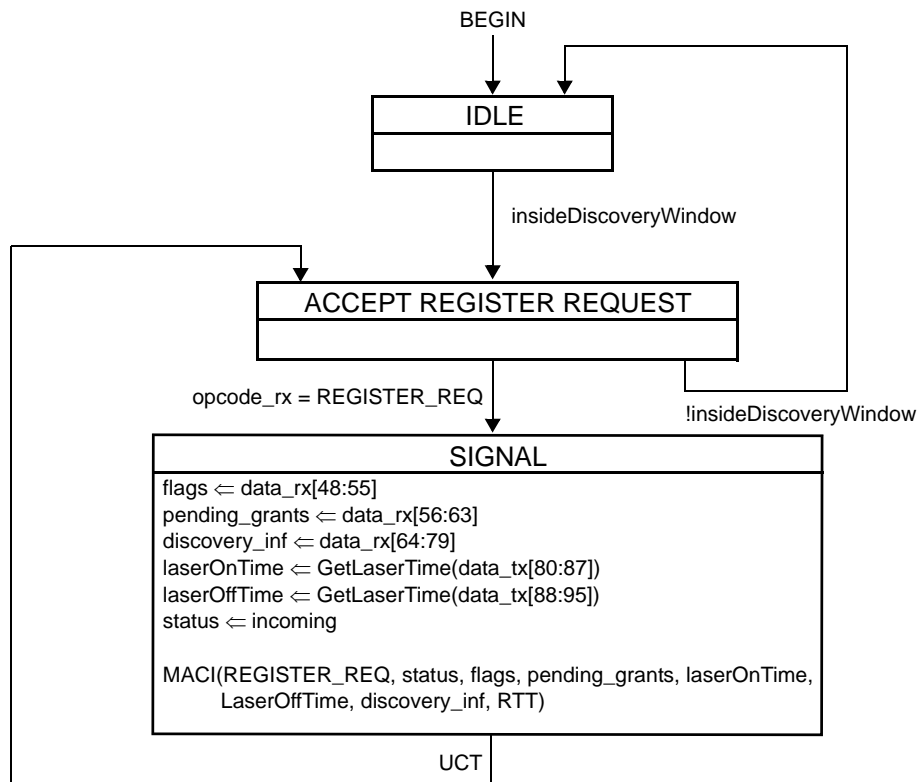

Figure 64–19—Discovery Processing OLT Process Requests State Diagram

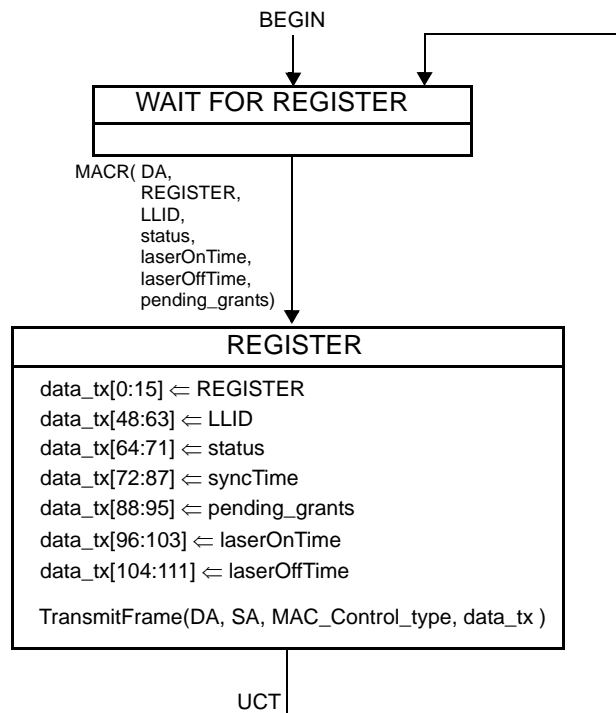
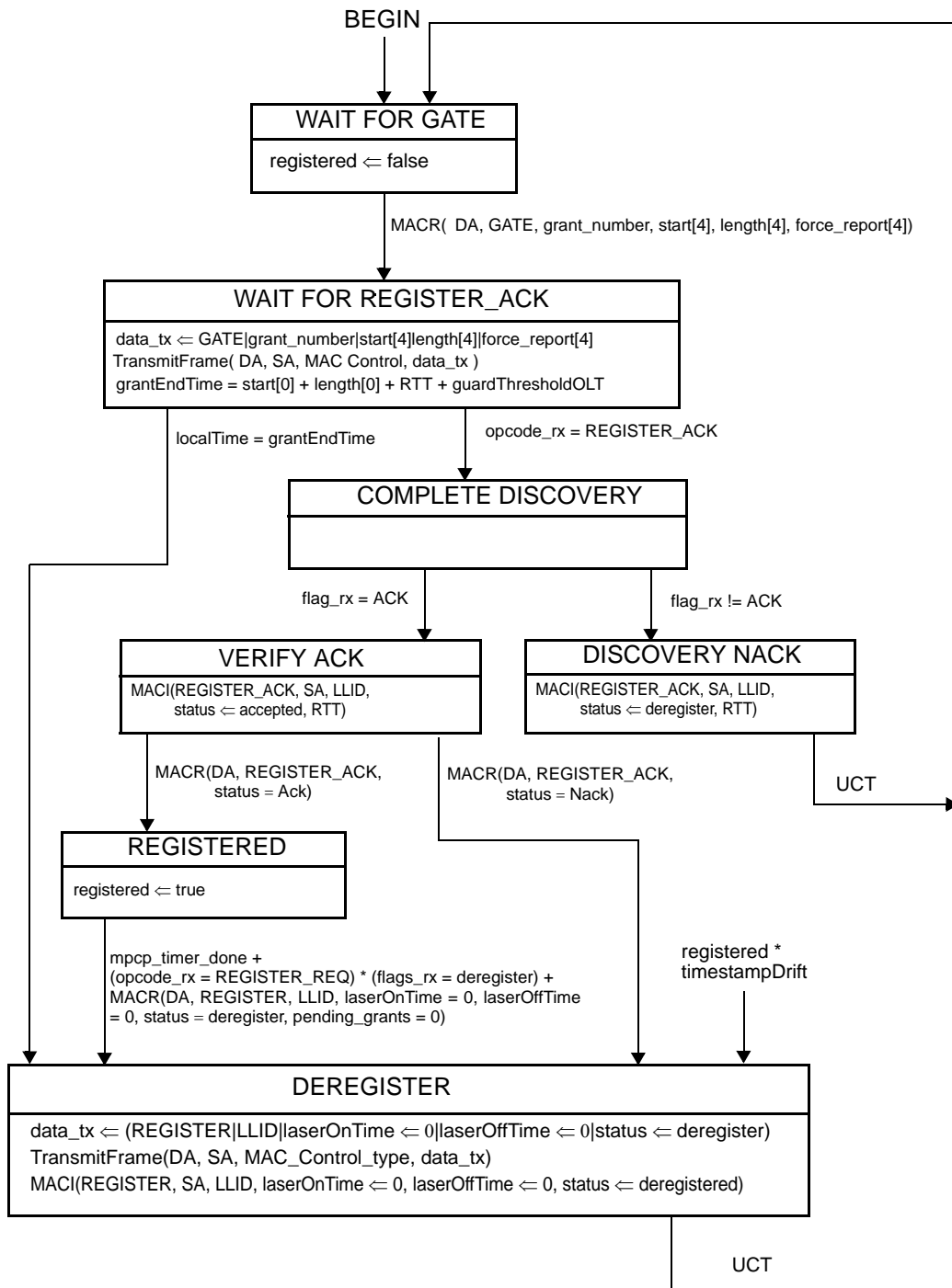

Figure 64–20—Discovery Processing OLT Register State Diagram



NOTE— The MAC Control Client issues the grant following the REGISTER message, taking the ONU processing delay of REGISTER message into consideration.

**Figure 64–21—Discovery Processing OLT Final Registration State Diagram**

1  
2  
3  
4  
5  
6  
7  
8  
9  
10  
11  
12  
13  
14  
15  
16  
17  
18  
19  
20  
21  
22  
23  
24  
25  
26  
27  
28  
29  
30  
31  
32  
33  
34  
35  
36  
37  
38  
39  
40  
41  
42  
43  
44  
45  
46  
47  
48  
49  
50  
51  
52  
53  
54





### 64.3.4 Report Processing

The Report Processing functional block has the responsibility of dealing with queue report generation and termination in the network. Reports are generated by higher layers and passed to the MAC Control sublayer by the MAC Control clients. Status reports are used to signal bandwidth needs as well as for arming the OLT watchdog timer.

Reports shall be generated periodically, even when no request for bandwidth is being made. This keeps a watchdog timer in the OLT from expiring and deregistering the ONU. For proper operation of this mechanism the OLT shall grant the ONU periodically.

The Report Processing functional block, and its MPCP protocol elements are designed for use in conjunction with an 802.1P capable bridge.

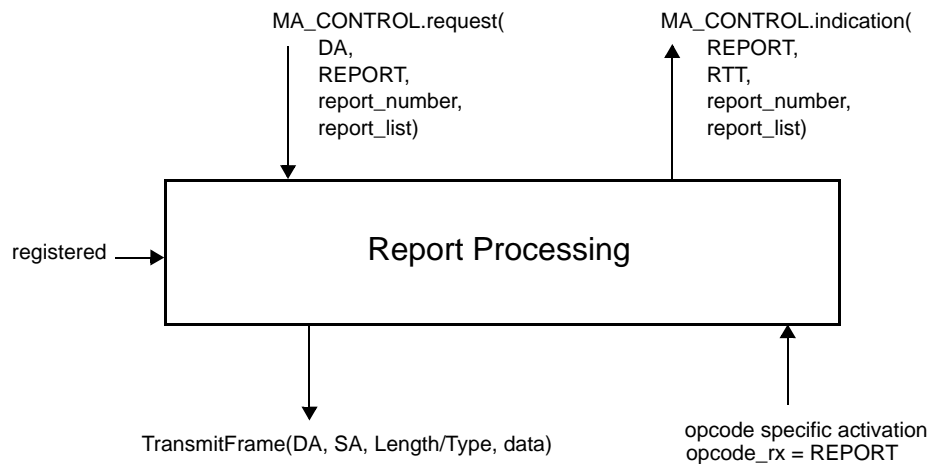

**Figure 64–23—Report Processing Service Interfaces**

#### 64.3.4.1 Constants

**mpcp\_timeout**

This constant represents the maximum allowed interval of time between two MPCPDU messages. Failure to receive at least one frame within this interval is considered a fatal fault and leads to deregistration. This parameter is expressed in the units of time\_quanta.

TYPE                   32-bit unsigned  
 VALUE                 0x03B9ACA0

**report\_timeout**

This constant represents the maximum allowed interval of time between two REPORT messages generated by the ONU. This parameter is expressed in the units of time\_quanta.

TYPE                   32-bit unsigned  
 VALUE                 0x002FAF08

#### 64.3.4.2 Variables

**BEGIN**

This variable is used when initiating operation of the functional block state machine. It is set to true following initialization and every reset.

TYPE:                   boolean

**data\_rx**

This variable is defined in 64.2.2.3.

1 data\_tx  
2 This variable is defined in 64.2.2.3.  
3 opcode\_rx  
4 This variable is defined in 64.2.2.3.  
5 opcode\_tx  
6 This variable is defined in 64.2.2.3.  
7 registered  
8 This variable is defined in 64.3.3.2.  
9

#### 10 64.3.4.3 Functions

11  
12 TransmitFrame(DA, SA, Length/Type, data)  
13 This function is defined in 64.2.2.4.  
14

#### 15 64.3.4.4 Timers

16  
17 report\_periodic\_timer  
18 ONUs are required to generate REPORT MPCPDUs with a periodicity of less than  
19 report\_timeout value. This timer counts down time remaining before a forced generation of  
20 a REPORT message in an ONU.  
21 mpcp\_timer  
22 This timer is defined in 64.3.3.4.  
23

#### 24 64.3.4.5 Messages

25  
26 MA\_CONTROL.request(DA, REPORT, report\_number, report\_list)  
27 This service primitive is used by a MAC Control client to request the Report Process at the  
28 ONU to transmit a queue status report. This primitive may be called at variable intervals,  
29 independently of the granting process, in order to reflect the time varying aspect of the  
30 network. This primitive uses the following parameters:  
31  
32 DA: multicast MAC Control address as defined in Annex 31B.  
33 REPORT: opcode for REPORT MPCPDU as defined in Table  
34 31A-1.  
35 report\_number: the number of queue status report sets located in report list.  
36 The report\_number value ranges from 0 to a maximum of  
37 13.  
38 report\_list: the list of queue status reports. A queue status report  
39 consists of two fields: valid and status. The parameter  
40 valid, is a boolean array with length of 8, '0' or false  
41 indicates that the corresponding status field is not present  
42 (the length of status field is 0), while '1' or true indicates  
43 that the corresponding status field is present (the length of  
44 status field is 2 octets). The index of the array is meant to  
45 reflect the same numbered priority queue in the 802.1P  
46 nomenclature.  
47 The parameter status is an array of 16-bit unsigned integer  
48 values. This array consists only of entries whose  
49 corresponding bit in field valid is set to true.  
50  
51  
52  
53  
54

MA\_CONTROL.indication(REPORT, RTT, report\_number, report\_list)

The service primitive issued by the Report Process at the OLT to notify the MAC Control client and higher layers the queue status of the MPCP link partner. This primitive may be called multiple times, in order to reflect the time-varying aspect of the network. This primitive uses the following parameters:

- REPORT: opcode for REPORT MPCPDU as defined in Table 31A-1.
- RTT: this parameter holds an updated round trip time value which is recalculated following each REPORT message reception.
- report\_number: the number of queue status report sets located in report list. The report\_number value ranges from 0 to a maximum of 13.
- report\_list: the list of queue status reports. A queue status report consists of two fields: valid and status. The parameter valid, is a boolean array with length of 8, '0' or false indicates that the corresponding status field is not present (the length of status field is 0), while '1' or true indicates that the corresponding status field is present (the length of status field is 2 octets). The index of the array is meant to reflect the same numbered priority queue in the 802.1P nomenclature.  
 The parameter status is an array of 16-bit unsigned integer values. This array consists only of entries whose corresponding bit in filed valid is set to true.

Opcode-specific function(opcode)

Functions exported from opcode specific blocks that are invoked on the arrival of a MAC Control message of the appropriate opcode.

**64.3.4.6 State Diagram**

The report process in the OLT shall implement the report processing state diagram as shown in Figure 64-23. The report process in the ONU shall implement the report processing state diagram as shown in Figure 64-24. Instantiation of state machines as described is performed for Multipoint MAC Control instances attached to unicast LLIDs only.

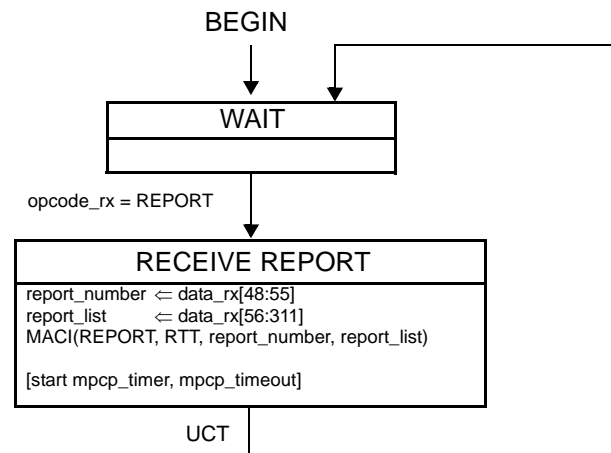

**Figure 64-24—Report Processing State Diagram at OLT**

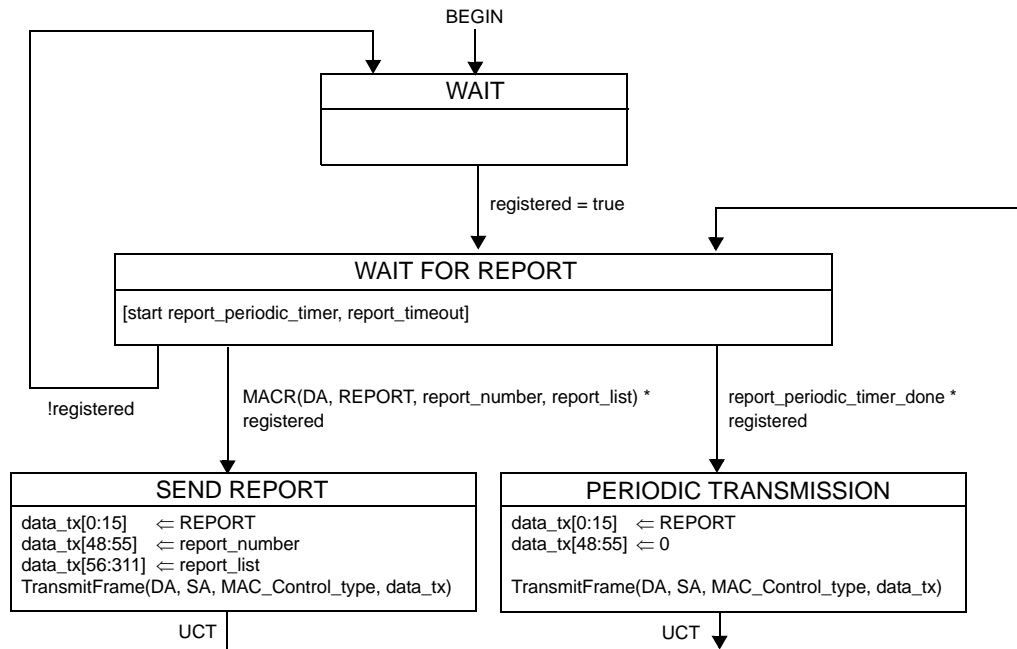

**Figure 64–25—Report Processing State Diagram at ONU**

### 64.3.5 Gate Processing

A key concept pervasive in Multipoint MAC Control is the ability to arbitrate a single transmitter out of a plurality of ONUs. The OLT controls an ONU's transmission by the assigning of grants.

The transmitting window of an ONU is indicated in GATE message where start time and length are specified. An ONU will begin transmission when its localTime counter matches start\_time value indicated in the GATE message. An ONU will conclude its transmission with sufficient margin to ensure that the laser is turned off before the grant length interval has elapsed.

Multiple outstanding grants may be issued to each ONU. The OLT shall not issue more than the maximal supported maximal outstanding grants as advertised by the ONU during registration (see pending grants in 64.3.6.3).

In order to maintain the watchdog timer at the ONU, grants are periodically generated. For this purpose empty GATE messages may be issued periodically.

When registered, the ONU ignores all gate messages where the discovery flag is set.

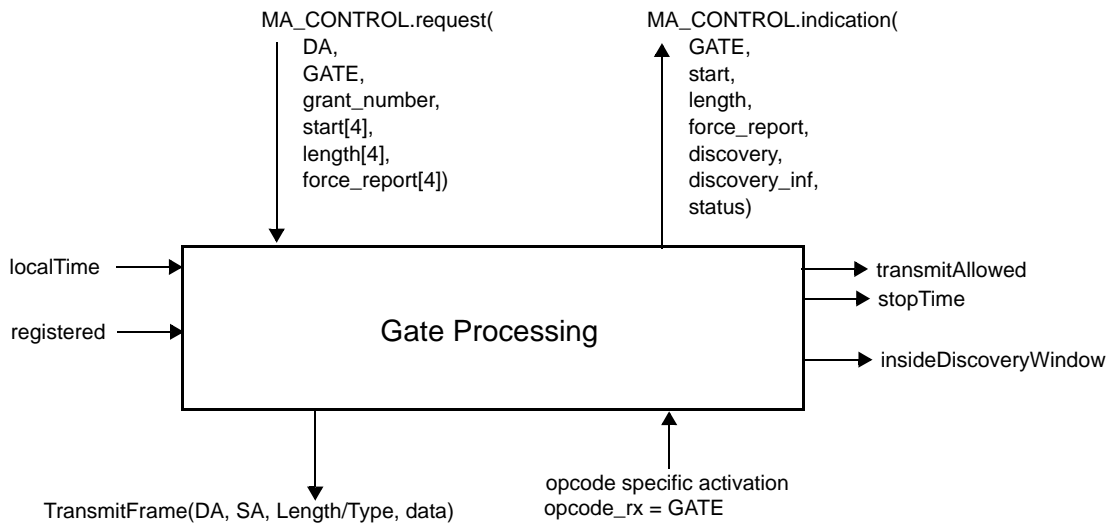

**Figure 64–26—Gate Processing Service Interface**

**64.3.5.1 Constants**

**discoveryGrantLength**

This constant represents the duration of ONU’s transmission during discovery attempt. The value of discoveryGrantLength includes MPCPDU transmission time and tailGuard as defined in 64.2.2.1. discoveryGrantLength is represented in the units of time\_quanta.

TYPE: 32-bit unsigned  
 VALUE: 0x00000026

**gate\_timeout**

This constant represents the maximum allowed interval of time between two GATE messages generated by the OLT to the same ONU. gate\_timeout is represented in the units of time\_quanta.

TYPE 32-bit unsigned  
 VALUE 0x002FAF08

**max\_future\_grant\_time**

This constant holds the time limiting the future time horizon for a valid incoming grant. max\_future\_grant\_time is represented in the units of time\_quanta.

TYPE: 32-bit unsigned  
 VALUE: 0x03B9ACA0

**min\_processing\_time**

This constant is the time required for the ONU processing time. min\_processing\_time is represented in the units of time\_quanta.

TYPE: 32-bit unsigned  
 VALUE: 0x00000400

**64.3.5.2 Variables**

**BEGIN**

This variable is used when initiating operation of the functional block state machine. It is set to true following initialization and every reset.

TYPE: boolean

1 counter  
2 This variable is used as a loop iterator counting the number of incoming grants in a GATE  
3 message.  
4 TYPE: integer  
5  
6 currentGrant  
7 This variable is used for local storage of a pending grant state during processing. It is  
8 dynamically set by the Gate Processing functional block and is not exposed.  
9 The state is a structure field composed of multiple subfields.  
10 TYPE: structure {  
11 DA 48-bit unsigned, a.k.a MAC address type  
12 start 32-bit unsigned  
13 length 16-bit unsigned  
14 force\_report boolean  
15 discovery boolean}  
16  
17 data\_rx  
18 This variable is defined in 64.2.2.3.  
19  
20 data\_tx  
21 This variable is defined in 64.2.2.3.  
22  
23 effectiveLength  
24 This variable is used for temporary storage of a normalized net time value. It holds the net  
25 effective length of a grant normalized for elapsed time, and compensated for the periods  
26 required to turn the laser on and off, and waiting for receiver lock.  
27 TYPE: 32-bit unsigned  
28  
29 fecEnabled  
30 This variable is defined in 64.2.2.3.  
31  
32 grantList  
33 This variable is used for storage of the list of pending grants. It is dynamically set by the  
34 Gate Processing functional block and is not exposed. Each time a grant is received it is  
35 added to the list.  
36 The list elements are structure fields composed of multiple subfields.  
37 The list is indexed by the start subfield in each element for quick searches.  
38 TYPE: list of elements having the structure define in currentGrant  
39  
40 insideDiscoveryWindow  
41 This variable is defined in 64.3.3.2.  
42  
43 maxDelay  
44 This variable holds the maximum delay that can be applied by an ONU before sending the  
45 REGISTER MPCPDU. This delay is calculated such that the ONU would have sufficient  
46 time to transmit the REGISTER message and its associated overhead (FEC parity date,  
47 end-of-frame sequence, etc.) and terminate the laser before the end of the discovery grant.  
48 TYPE 16-bit unsigned  
49  
50 nextGrant  
51 This variable is used for local storage of a pending grant state during processing. It is  
52 dynamically set by the Gate Processing functional block and is not exposed. The content of  
53 the variable is the next grant to become active.  
54 TYPE: element having same structure as defined in currentGrant  
55  
56 nextStopTime  
57 This variable holds the value of the localTime counter corresponding to the end of the next  
58 grant.  
59 TYPE: 32-bit unsigned  
60  
61 registered  
62 This variable is defined in 64.3.3.2.  
63  
64

stopTime	1
This variable is defined in 64.2.2.3.	2
syncTime	3
This variable is defined in 64.3.3.2.	4
transmitAllowed	5
This variable is defined in 64.2.2.3.	6

### 64.3.5.3 Functions

confirmDiscovery(data)	11
This function is used to check whether the current Discovery Window is open for the given ONU or not. This function is further defined in 64A.2.3.1 and 64B.2.4.1 for 1000 Mb/s and 10 Gb/s EPONs, respectively.	12
empty(list)	15
This function is use to check whether the list is empty. When there are no elements queued in the list, the function returns true. Otherwise, a value of false is returned.	16
InsertInOrder(sorted_list, inserted_element)	18
This function is used to queue an element inside a sorted list. The queueing order is sorted. In the condition that the list is full the element may be discarded. The length of the list is dynamic and it's maximal size equals the value advertised during registration as maximum number of pending grants.	19
IsBroadcast(grant)	20
This function is used to check whether its argument represents a broadcast grant, i.e., grant given to multiple ONUs. This is determined by the destination MAC address of the corresponding GATE message. The function returns the value true when MAC address is a global assigned MAC Control address as defined in Annex 31B, and false otherwise.	21
PeekHead(sorted_list)	22
This function is used to check the content of a sorted list. It returns the element at the head of the list without dequeuing the element.	23
Random(r)	24
This function is used to compute a random integer number uniformly distributed between 0 and r. The randomly generated number is then returned by the function.	25
RemoveHead(sorted_list)	26
This function is used to dequeue an element from the head of a sorted list. The return value of the function is the dequeued element.	27
tqSize	28
This function is defined in 64.2.2.4.	29
TransmitFrame(DA, SA, Length/Type, data)	30
This function is defined in 64.2.2.4.	31

### 64.3.5.4 Timers

gntStTmr	32
This timer is used to wait for the event signaling the start of a grant window.	33
VALUE: The timer value is dynamically set according to the signaled grant start time.	34
gntWinTmr	35
This timer is used to wait for the event signaling the end of a grant window.	36
VALUE: The timer value is dynamically set according to the signaled grant length.	37

1 gate\_periodic\_timer

2 The OLT is required to generate GATE MPCPDUs with a periodicity of less than  
3 gate\_timeout value. This timer counts down time remaining before a forced generation of  
4 a GATE message in the OLT.

5 mpcp\_timer

6 This timer is defined in 64.3.3.4.

7 rndDlyTmr

8 This timer is used to measure a random delay inside the discovery window. The purpose of  
9 the delay is to apriori reduce the probability of transmission overlap during the registration  
10 process, and thus lowering the expectancy of registration time in the PON.

11 VALUE: A random value less than the net discovery window size less the  
12 REGISTER\_REQ MPCPDU frame size less the idle period and laser turn on and off delays  
13 less the preamble size less the IFG size. The timer value is set dynamically based on the  
14 parameters passed from the client.  
15

### 16 64.3.5.5 Messages

17  
18 MA\_CONTROL.request(DA, GATE, grant\_number, start[4], length[4], force\_report[4])

19 This service primitive is defined in 64.3.3.5.

20 MA\_CONTROL.indication(GATE, start, length, force\_report, discovery, discovery\_inf, status)

21 This service primitive issued by the Gate Process at the ONU to notify the MAC Control  
22 client and higher layers that a grant is pending. This primitive is invoked multiple times  
23 when a single GATE message arrives with multiple grants. It is also generated at the start  
24 and end of each grant as it becomes active. This primitive uses the following parameters:

25	GATE:	opcode for GATE MPCPDU as defined in Table 31A–1.
26	start:	start time of the grant. This parameter is not present when
27		the status value is deactive.
28	length:	length of the grant. This parameter is not present when the
29		status value is deactive.
30	force_report:	flags indicating whether a REPORT message should be
31		transmitted in this grant. This parameter is not present
32		when the status value is deactive.
33	discovery:	This parameter holds the value true when the grant is to be
34		used for the discovery process, and false otherwise. This
35		parameter is not present when the status value is deactive.
36	discovery_inf:	This parameter holds the contents Discovery Information
37		field as specified in 64.3.6.1.
38	status:	This parameter takes the value <i>arrive</i> on grant reception,
39		<i>active</i> when a grant becomes active, and <i>deactive</i> at the
40		end of a grant.

41  
42  
43 Opcode-specific function(opcode)

44 Functions exported from opcode specific blocks that are invoked on the arrival of a MAC  
45 Control message of the appropriate opcode.  
46  
47  
48  
49  
50  
51  
52  
53  
54



### 64.3.5.6 State Diagrams

The gating process in the OLT shall implement the gate processing state diagram as shown in Figure 64–26. The gating process in the ONU shall implement the gate processing state diagram as shown in Figure 64–27. Instantiation of state machines as described is performed for all Multipoint MAC Control instances.

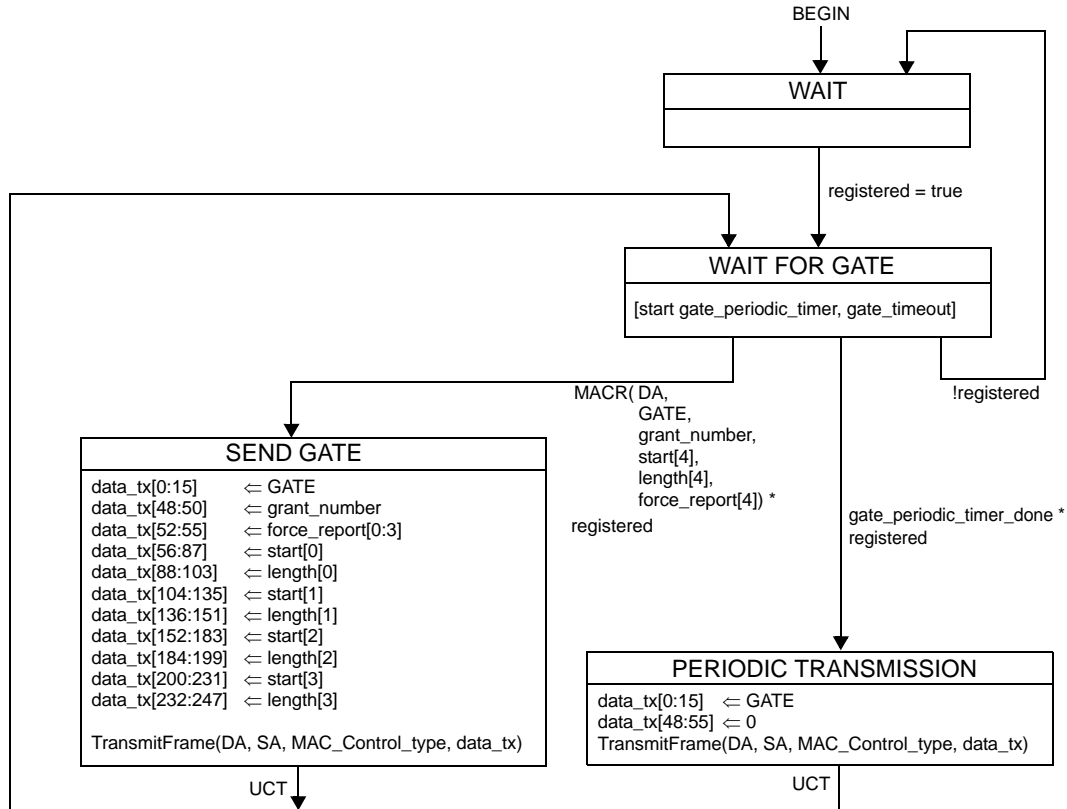
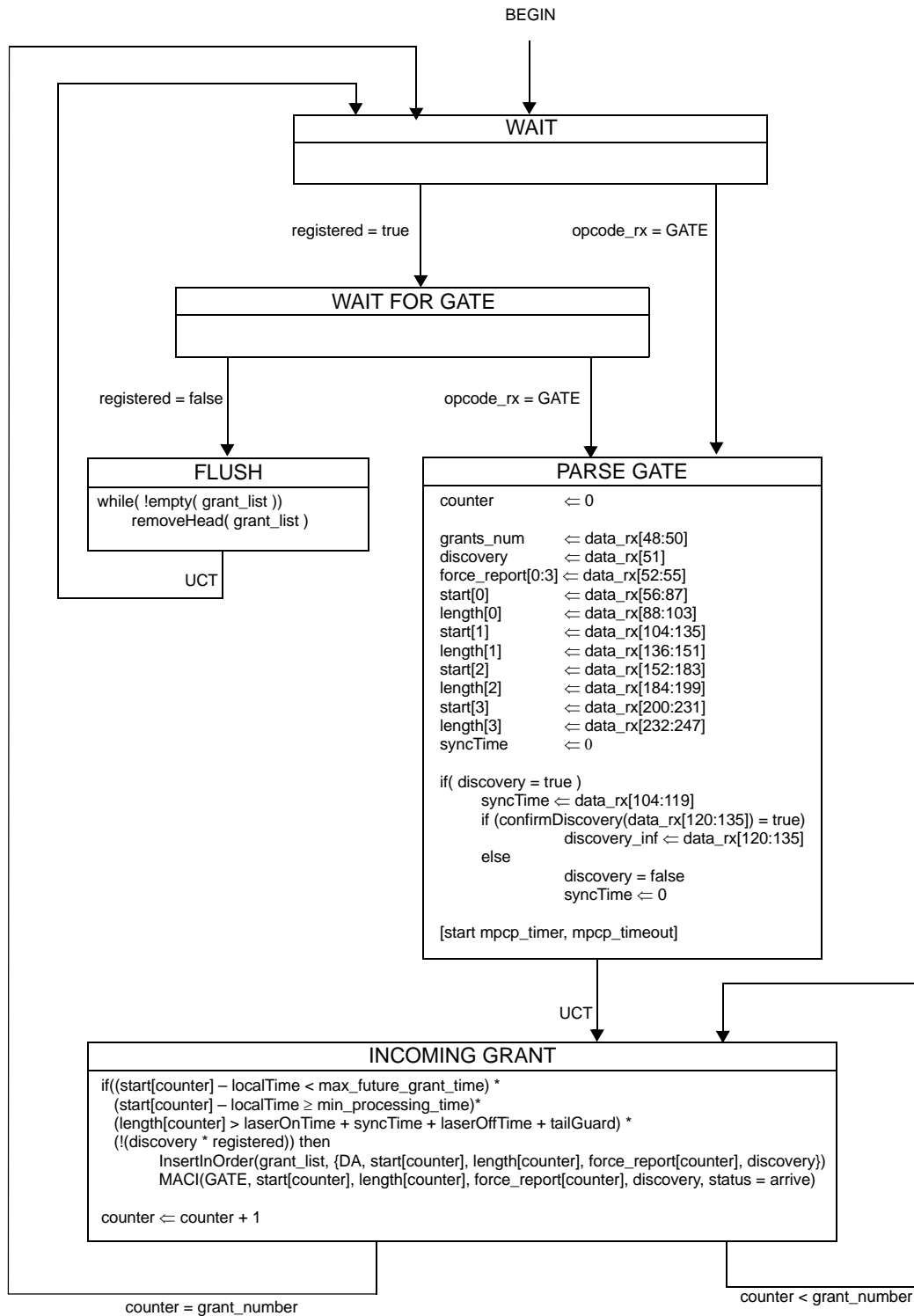

Figure 64–27—Gate Processing State Diagram at OLT

1  
2  
3  
4  
5  
6  
7  
8  
9  
10  
11  
12  
13  
14  
15  
16  
17  
18  
19  
20  
21  
22  
23  
24  
25  
26  
27  
28  
29  
30  
31  
32  
33  
34  
35  
36  
37  
38  
39  
40  
41  
42  
43  
44  
45  
46  
47  
48  
49  
50  
51  
52  
53  
54



**Figure 64–28—Gate Processing ONU Programming State Diagram**

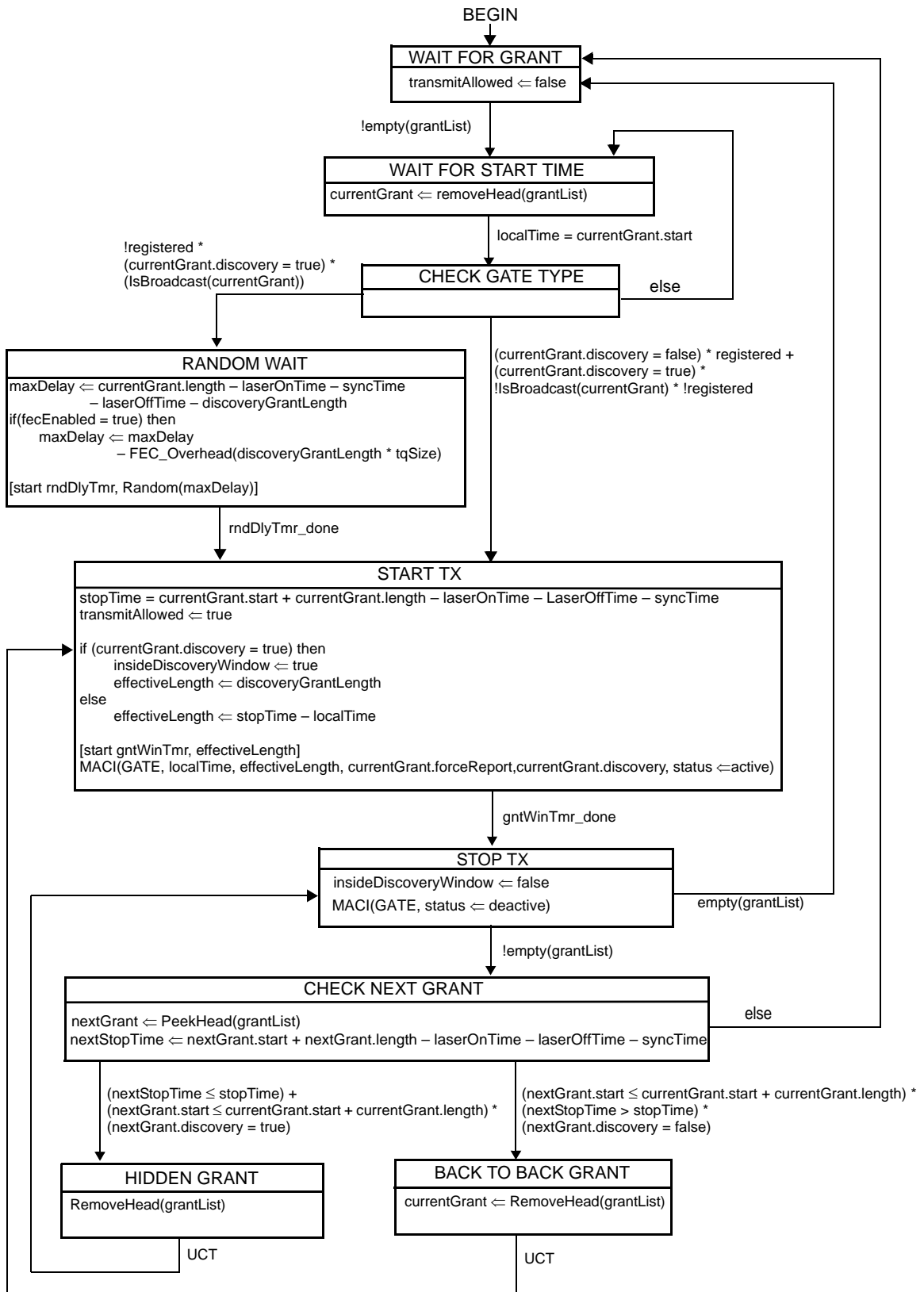

Figure 64–29—Gate Processing ONU Activation State Diagram

1  
2  
3  
4  
5  
6  
7  
8  
9  
10  
11  
12  
13  
14  
15  
16  
17  
18  
19  
20  
21  
22  
23  
24  
25  
26  
27  
28  
29  
30  
31  
32  
33  
34  
35  
36  
37  
38  
39  
40  
41  
42  
43  
44  
45  
46  
47  
48  
49  
50  
51  
52  
53  
54



### 64.3.6.1 GATE description

The purpose of GATE message is to grant transmission windows to ONUs for both discovery messages and normal transmission. Up to four grants can be included in a single GATE message. The number of grants can also be set to zero for using the GATE message as an MPCP keep alive from OLT to the ONU.

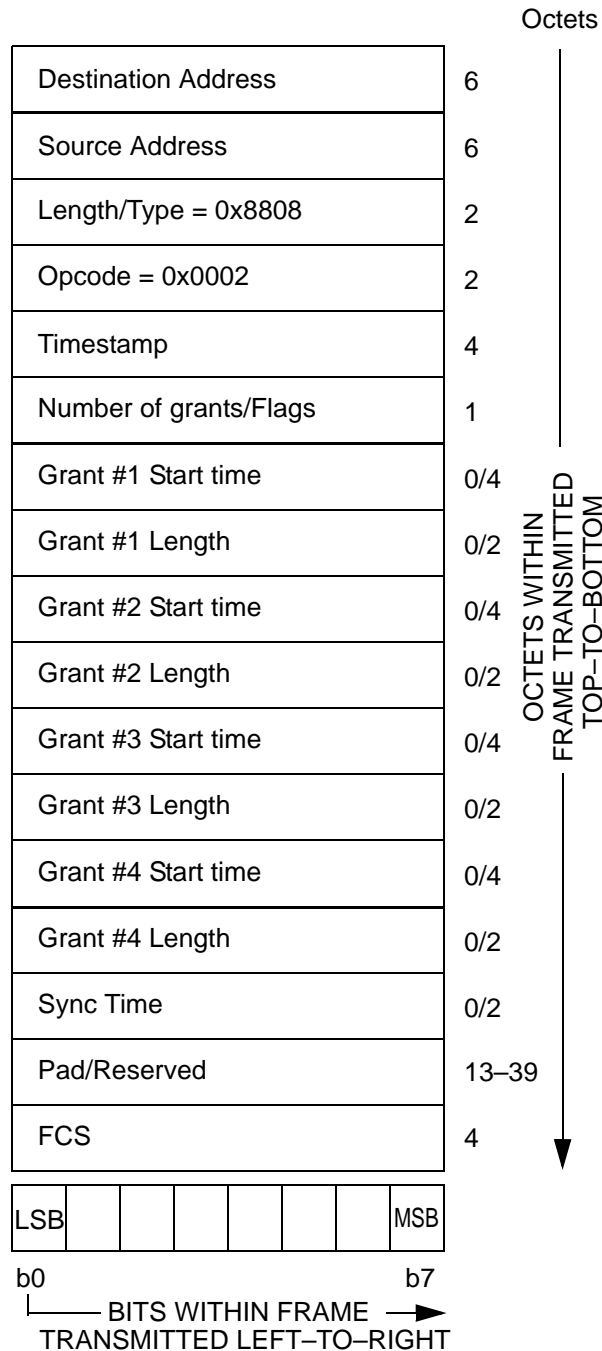

**Figure 64–31—GATE MPCPDU**

The GATE MPCPDU is an instantiation of the Generic MPCPDU, and is further defined using the following definitions:

- a) Opcode. The opcode for the GATE MPCPDU is 0x0002.

1  
2  
3  
4  
5  
6  
7  
8  
9  
10  
11  
12  
13  
14  
15  
16  
17  
18  
19  
20  
21  
22  
23  
24  
25  
26  
27  
28  
29  
30  
31  
32  
33  
34  
35  
36  
37  
38  
39  
40  
41  
42  
43  
44  
45  
46  
47  
48  
49  
50  
51  
52  
53  
54

- b) **Flags.** This is an 8 bit flag register that holds the following flags: The Number of grants field contains the number of grants, composed of valid Length, Start Time pairs in this MPCPDU. This is a number between 0 and 4. Note: when Number of grants is set to 0, sole purpose of message is conveying of timestamp to ONU.  
 The Discovery flag field indicates that the signaled grants would be used for the discovery process, in which case a single grant shall be issued in the gate message.  
 The Force Report flag fields ask the ONU to issue a REPORT message related to the corresponding grant number at the corresponding transmission opportunity indicated in this GATE.

**Table 64–1—GATE MPCPDU Number of grants/Flags Fields**

Bit	Flag Field	Values
0–2	Number of grants	0 – 4
3	Discovery	0 – Normal GATE 1 – Discovery GATE
4	Force Report Grant 1	0 – No action required 1 – A REPORT frame should be issued at the corresponding transmission opportunity indicated in Grant 1
5	Force Report Grant 2	0 – No action required 1 – A REPORT frame should be issued at the corresponding transmission opportunity indicated in Grant 2
6	Force Report Grant3	0 – No action required 1 – A REPORT frame should be issued at the corresponding transmission opportunity indicated in Grant 3
7	Force Report Grant 4	0 – No action required 1 – A REPORT frame should be issued at the corresponding transmission opportunity indicated in Grant 4

- c) **Grant #n Length.** Length of the signaled grant, this is an 16-bit unsigned field. The length is counted in 1 time\_quantum increments. There are 4 Grants that are possibly packed into the GATE MPCPDU. The laserOnTime, syncTime, and laserOffTime are included in and thus consume part of Grant #n Length.
- d) **Grant #n Start Time.** Start time of the grant, this is an 32-bit unsigned field. The start time is compared to the local clock, to correlate the start of the grant. Transmitted values shall satisfy the condition Grant #n Start Time < Grant #n+1 Start Time for consecutive grants within the same GATE MPCPDU.
- e) **Sync Time.** This is an unsigned 16 bit value signifying the required synchronization time of the OLT receiver. During the synchronization time the ONU shall send IDLE code-pairs. The value is counted in 1 time\_quantum increments. The advertised value includes synchronization requirement on all receiver elements including PMD, PMA and PCS. This field is present only when the gate is a discovery gate, as signaled by the Discovery flag and is not present otherwise.
- f) **Discovery Information.** This is an 16 bit flag register. This field is present only when the GATE is a discovery GATE, as signaled by the Discovery flag and is not present otherwise. Internal structure of the Discovery Information field is presented in 64A.3.1 for 1000 Mb/s EPONs and in 64B.3.1 for 10 Gb/s EPONs.
- g) **Pad/Reserved.** This is an empty field that is transmitted as zeros, and ignored on reception when constructing a complying MPCP protocol implementation. The size of this field depends on the used Grant #n Length/Start Time entry-pairs as well as the presence of the Sync Time and Discovery Information fields, and varies in length from 13 – 39 accordingly.

The GATE MPCPDU shall be generated by a MAC Control instance mapped to an active ONU, and as such shall be marked with a unicast type of LLID, except when the discovery flag is set where the MAC Control instance is mapped to all ONUs and such frame is marked by the appropriate broadcast LLID (see 64.3.2.3).

**64.3.6.2 REPORT description**

REPORT messages have several functionalities. Time stamp in each REPORT message is used for round trip (RTT) calculation. In the REPORT messages ONUs indicate the upstream bandwidth needs they request per 802.1Q priority queue. REPORT messages are also used as keep-alives from ONU to OLT. ONUs issue REPORT messages periodically in order to maintain link health at the OLT as defined in 64.3.4. In addition, the OLT may specifically request a REPORT message.

The REPORT MPCPDU is an instantiation of the Generic MPCPDU, and is further defined using the following definitions:

- a) Opcode. The opcode for the REPORT MPCPDU is 0x0003.
- b) Number of Queue Sets. This field specifies the number of requests in the REPORT message. A REPORT frame may hold multiple sets of Report bitmap and Queue #n as specified in the Number of Queue Sets field.
- c) Report bitmap. This is an 8 bit flag register that indicates which queues are represented in this REPORT MPCPDU.

**Table 64–2—REPORT MPCPDU Report bitmap fields**

Bit	Flag Field	Values
0	Queue 0	0 – queue 0 report is not present; 1 – queue 0 report is present
1	Queue 1	0 – queue 1 report is not present; 1 – queue 1 report is present
2	Queue 2	0 – queue 2 report is not present; 1 – queue 2 report is present
3	Queue 3	0 – queue 3 report is not present; 1 – queue 3 report is present
4	Queue 4	0 – queue 4 report is not present; 1 – queue 4 report is present
5	Queue 5	0 – queue 5 report is not present; 1 – queue 5 report is present
6	Queue 6	0 – queue 6 report is not present; 1 – queue 6 report is present
7	Queue 7	0 – queue 7 report is not present; 1 – queue 7 report is present

- d) Queue #n Report. This value represents the length of queue# n at time of REPORT message generation. The reported length shall be adjusted to account for the necessary inter-frame spacing and FEC parity data overhead, if FEC is enabled. The Queue #n Report field is an unsigned 16 bit integer representing transmission request in the units of time\_quanta. This field is present only when the corresponding flag in the Report bitmap is set.
- e) Pad/Reserved. This is an empty field that is transmitted as zeros, and ignored on reception when constructing a complying MPCP protocol implementation. The size of this field depends on the used Queue Report entries, and accordingly varies in length from 0 to 39.

The REPORT MPCPDU shall be generated by a MAC Control instance mapped to an active ONU, and as such shall be marked with a unicast type of LLID.

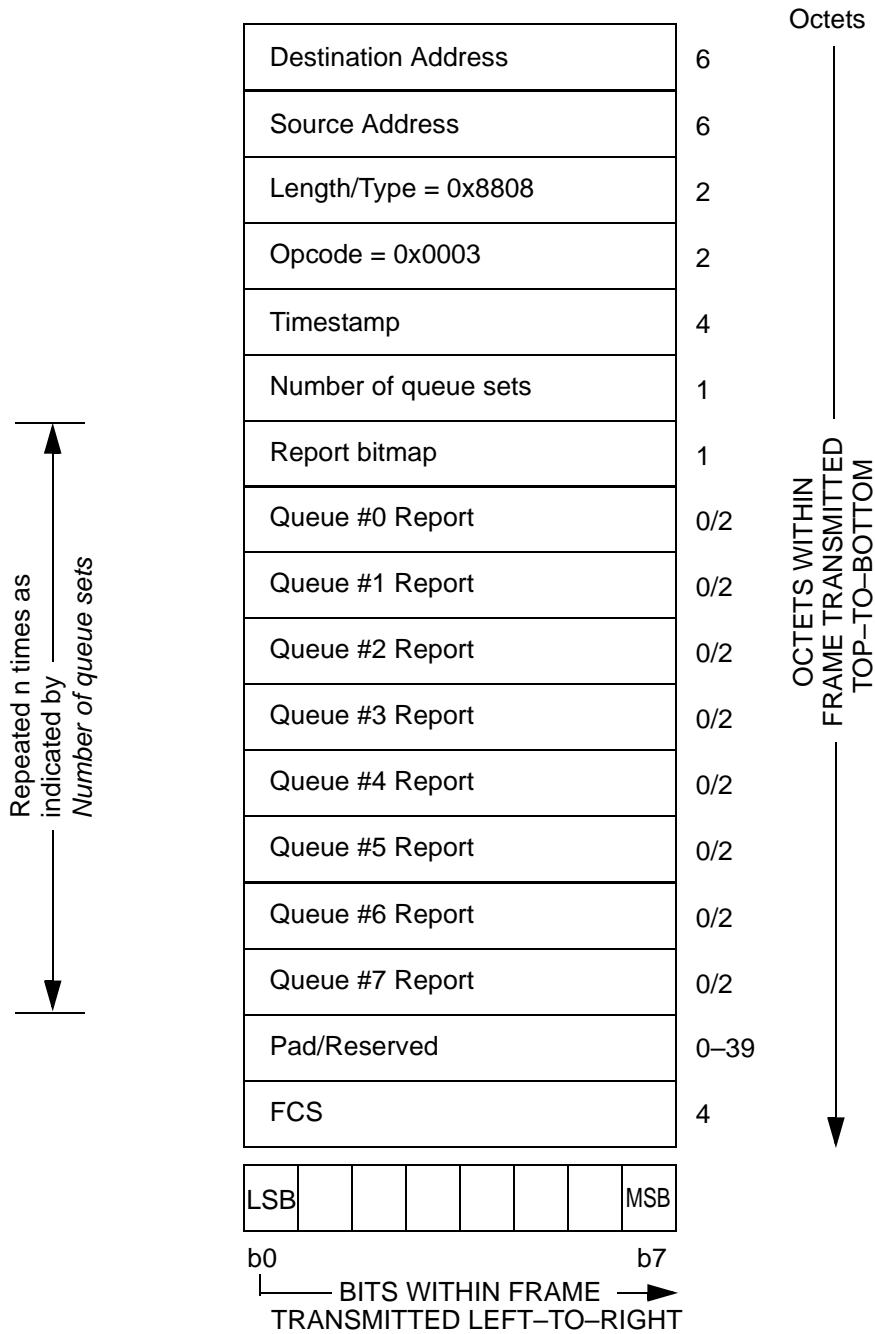

**Figure 64-32—REPORT MPCPDU**



### 64.3.6.3 .REGISTER\_REQ description

The REGISTER\_REQ MPCPDU is an instantiation of the Generic MPCPDU, and is further defined using the following definitions:

- a) Opcode. The opcode for the REGISTER\_REQ MPCPDU is 0x0004.
- b) Flags. This is an 8 bit flag register that indicates special requirements for the registration.

**Table 64–3—REGISTER\_REQ MPCPDU Flags fields**

Value	Indication	Comment
0	reserved	Ignored on reception.
1	Register	Registration attempt for ONU.
2	reserved	Ignored on reception.
3	Deregister	This is a request to deregister the ONU. Subsequently, the MAC is deallocated and the LLID may be reused.
4–255	reserved	Ignored on reception.

- c) Pending grants. This is an unsigned 8 bit value signifying the maximum number of future grants the ONU is configured to buffer. The OLT should not grant the ONU more than this maximum number of Pending grants vectors comprised of {start, length, force\_report, discovery} into the future.
- d) Discovery Information. This is an 16 bit flag register. Internal structure of the Discovery Information field is presented in 64A.3.2 for 1000 Mb/s EPONs and in 64B.3.2 for 10 Gb/s EPONs.
- e) Laser On Time. This is an unsigned 8 bit value signifying the Laser On Time, characteristic for the given ONU transmitter. The value is expressed in the units of time\_quanta. Internal structure of the Laser On Time field is presented in 64A.3.2 for 1000 Mb/s EPONs and in 64B.3.2 for 10 Gb/s EPONs.
- f) Laser Off Time. This is an unsigned 8 bit value signifying the Laser Off Time, characteristic for the given ONU transmitter. The value is expressed in the units of time\_quanta. Internal structure of the Laser Off Time field is presented in 64A.3.2 for 1000 Mb/s EPONs and in 64B.3.2 for 10 Gb/s EPONs.
- g) Pad/Reserved. This is an empty field that is transmitted as zeros, and ignored on reception when constructing a complying MPCP protocol implementation.

1  
2  
3  
4  
5  
6  
7  
8  
9  
10  
11  
12  
13  
14  
15  
16  
17  
18  
19  
20  
21  
22  
23  
24  
25  
26  
27  
28  
29  
30  
31  
32  
33  
34  
35  
36  
37  
38  
39  
40  
41  
42  
43  
44  
45  
46  
47  
48  
49  
50  
51  
52  
53  
54

The REGISTER\_REQ MPCPDU shall be generated by a MAC Control instance mapped to an undiscovered ONU, and as such shall be marked with a broadcast type of LLID (see 64.3.2.3).

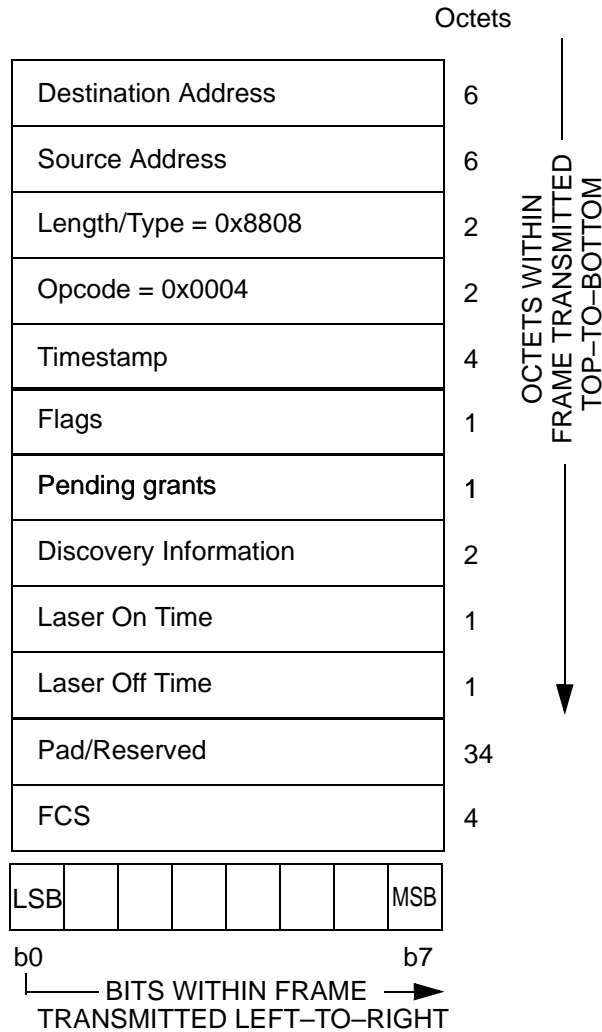

**Figure 64-33—REGISTER\_REQ MPCPDU**

#### 64.3.6.4 REGISTER description

The REGISTER MPCPDU is an instantiation of the Generic MPCPDU, and is further defined using the following definitions:

- a) DA. The destination address used shall be an individual MAC address.
- b) Opcode. The opcode for the REGISTER MPCPDU is 0x0005.
- c) Assigned Port. This field holds a 16-bit unsigned value reflecting the LLID of the port assigned following registration.
- d) Flags. this is an 8 bit flag register that indicates special requirements for the registration.

**Table 64-4—REGISTER MPCPDU Flags field**

Value	Indication	Comment
0	Reserved	Ignored on reception.
1	Reregister	The ONU is explicitly asked to re-register.

**Table 64-4—REGISTER MPCPDU Flags field**

Value	Indication	Comment
2	Deregister	This is a request to deallocate the port and free the LLID. Subsequently, the MAC is deallocated.
3	Ack	The requested registration is successful.
4	Nack	The requested registration attempt is denied by the higher-layer-entity.
5-255	Reserved	Ignored on reception.

- e) Sync Time. This is an unsigned 16 bit value signifying the required synchronization time of the OLT receiver. During the synchronization time the ONU transmits only IDLE code-pairs. The value is counted in 1 time\_quantum increments. The advertised value includes synchronization requirement on all receiver elements including PMD, PMA and PCS.

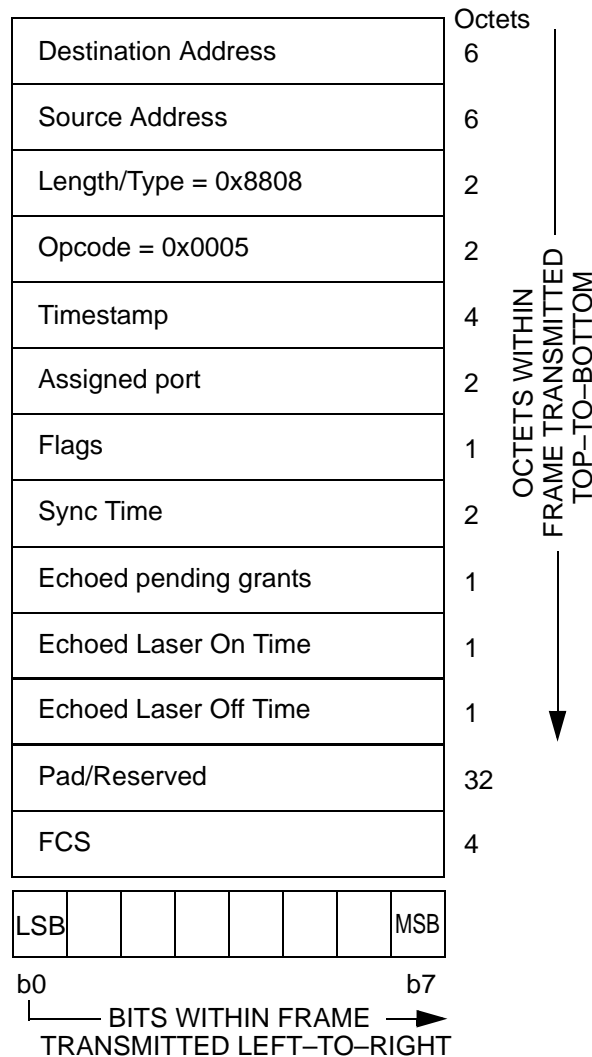

**Figure 64-34—REGISTER MPCPDU**

- f) Echoed pending grants. This is an unsigned 8 bit value signifying the number of future grants the ONU may buffer before activating. The OLT should not grant the ONU more than this number of grants into the future.

- g) Echoed Laser On Time. This is an unsigned 8 bit value signifying the Laser On Time, characteristic for the given ONU transmitter. The value is expressed in the units of time\_quanta. The value is delivered to the ONU for confirmation purposes only and its utilization is not prescribed in this specification. Internal structure of the Echoed Laser On Time field is presented in 64A.3.3 for 1000 Mb/s EPONs and in 64B.3.3 for 10 Gb/s EPONs.
- h) Echoed Laser Off Time. This is an unsigned 8 bit value signifying the Laser Off Time, characteristic for the given ONU transmitter. The value is expressed in the units of time\_quanta. The value is delivered to the ONU for confirmation purposes only and its utilization is not prescribed in this specification. Internal structure of the Echoed Laser Off Time field is presented in 64A.3.3 for 1000 Mb/s EPONs and in 64B.3.3 for 10 Gb/s EPONs.
- i) Pad/Reserved. This is an empty field that is transmitted as zeros, and ignored on reception when constructing a complying MPCP protocol implementation.

The REGISTER MPCPDU shall be generated by a MAC Control instance mapped to all ONUs and such frame is marked by the broadcast LLID (see 64.3.2.3).

#### 64.3.6.5 REGISTER\_ACK description

The REGISTER\_ACK MPCPDU is an instantiation of the Generic MPCPDU, and is further defined using the following definitions:

- a) Opcode. The opcode for the REGISTER\_ACK MPCPDU is 0x0006.
- b) Flags. this is an 8 bit flag register that indicates special requirements for the registration. Echoed assigned port. This field holds a 16-bit unsigned value reflecting the LLID of the port assigned following registration.

**Table 64–5—REGISTER\_ACK MPCPDU Flags fields**

Value	Indication	Comment
0	Nack	The requested registration attempt is denied by the higher-layer-entity.
1	Ack	The registration process is successfully acknowledged.
2–255	Reserved	Ignored on reception.

- c) Echoed Sync Time. This is an unsigned 16 bit value echoing the required synchronization time of the OLT receiver as previously advertised (see 64.3.6.4).
- d) Pad/Reserved. This is an empty field that is transmitted as zeros, and ignored at reception when constructing a complying MPCP protocol implementation.

The REGISTER\_ACK MPCPDU shall be generated by a MAC Control instance mapped to an active ONU, and as such shall be marked with a unicast type of LLID.

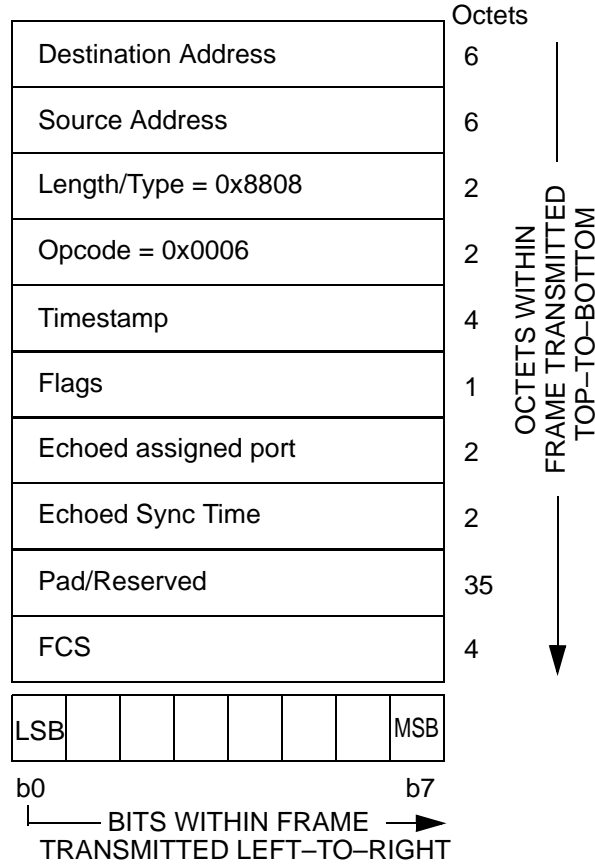

**Figure 64-35—REGISTER\_ACK MPCPDU**

1  
2  
3  
4  
5  
6  
7  
8  
9  
10  
11  
12  
13  
14  
15  
16  
17  
18  
19  
20  
21  
22  
23  
24  
25  
26  
27  
28  
29  
30  
31  
32  
33  
34  
35  
36  
37  
38  
39  
40  
41  
42  
43  
44  
45  
46  
47  
48  
49  
50  
51  
52  
53  
54

**64.4 Protocol implementation conformance statement (PICS) proforma for Clause 64, Multipoint MAC Control<sup>3</sup>**

**64.4.1 Introduction**

The supplier of a protocol implementation that is claimed to conform to Clause 64 Multipoint MAC Control, shall complete the following protocol implementation conformance statement (PICS) proforma.

A detailed description of the symbols used in the PICS proforma, along with instructions for completing the PICS proforma, can be found in Clause 21.

**64.4.2 Identification**

**64.4.2.1 Implementation identification**

Supplier	
Contact point for enquiries about the PICS	
Implementation Name(s) and Version(s)	
Other information necessary for full identification—e.g., name(s) and version(s) for machines and/or operating systems; System Name(s)	
NOTE 1—Only the first three items are required for all implementations; other information may be completed as appropriate in meeting the requirements for the identification.	
NOTE 2—The terms Name and Version should be interpreted appropriately to correspond with a supplier’s terminology (e.g., Type, Series, Model).	

**64.4.2.2 Protocol summary**

Identification of protocol standard	IEEE Std 802.3–2005, Clause 64, Multipoint MAC Control
Identification of amendments and corrigenda to this PICS proforma that have been completed as part of this PICS	
Have any Exception items been required? No [ ] Yes [ ] (See Clause 21; the answer Yes means that the implementation does not conform to IEEE Std 802.3–2005.)	
Date of Statement	

<sup>3</sup>Copyright release for PICS proformas: Users of this standard may freely reproduce the PICS proforma in this subclause so that it can be used for its intended purpose and may further publish the completed PICS.

### 64.4.3 Major capabilities/options

Item	Feature	Subclause	Value/Comment	Status	Support
*OLT	OLT functionality	64.1	Device supports functionality required for OLT	O/I	Yes [ ] No [ ]
*ONU	ONU functionality	64.1	Device supports functionality required for ONU	O/I	Yes [ ] No [ ]

### 64.4.4 PICS proforma tables for Multipoint MAC Control

#### 64.4.4.1 Compatibility Considerations

Item	Feature	Subclause	Value/Comment	Status	Support
CC1	Delay through MAC and PHY	64.3.2.4	Maximum delay variation of 16 ns (1 time_quantum)	M	Yes [ ]
CC2	OLT grant time delays	64.3.2.4	Not grant nearer than 1024 time_quanta into the future	OLT:M	Yes [ ]
CC3	ONU processing delays	64.3.2.4	Must process all messages in less than 1024 time_quanta	ONU:M	Yes [ ]
CC4	OLT grant issuance	64.3.2.4	Not grant more than one message every 1024 time_quanta	OLT:M	Yes [ ]

#### 64.4.4.2 Multipoint MAC Control

Item	Feature	Subclause	Value/Comment	Status	Support
OM1	OLT localTime	64.2.2.2	Track transmit clock	OLT:M	Yes [ ]
OM2	ONU localTime	64.2.2.2	Track receive clock	ONU:M	Yes [ ]
OM3	Random wait for transmitting REGISTER_REQ messages	64.3.3	Shorter than length of discovery time window	ONU:M	Yes [ ]
OM4	Periodic report generation	64.3.4	Reports are generated periodically	ONU:M	Yes [ ]
OM5	Periodic granting	64.3.4	Grants are issued periodically	OLT:M	Yes [ ]
OM6	Issuing of grants	64.3.5	Not issue more than maximal supported grants	OLT:M	Yes [ ]

1  
2  
3  
4  
5  
6  
7  
8  
9  
10  
11  
12  
13  
14  
15  
16  
17  
18  
19  
20  
21  
22  
23  
24  
25  
26  
27  
28  
29  
30  
31  
32  
33  
34  
35  
36  
37  
38  
39  
40  
41  
42  
43  
44  
45  
46  
47  
48  
49  
50  
51  
52  
53  
54

### 64.4.4.3 State Machines

Item	Feature	Subclause	Value/Comment	Status	Support
SM1	Multipoint Transmission Control	64.2.2.7	Meets the requirements of Figure 64–9	M	Yes [ ]
SM2	OLT Control Parser	64.2.2.7	Meets the requirements of Figure 64–10	M	Yes [ ]
SM3	ONU Control Parser	64.2.2.7	Meets the requirements of Figure 64–11	M	Yes [ ]
SM4	OLT Control Multiplexer	64.2.2.7	Meets the requirements of Figure 64–12	OLT:M	Yes [ ]
SM5	ONU Control Multiplexer	64.2.2.7	Meets the requirements of Figure 64–13	OLT:M	Yes [ ]
SM6	Discovery Processing OLT Window Setup	64.3.3.6	Meets the requirements of Figure 64–18	OLT:M	Yes [ ]
SM7	Discovery Processing OLT Process Requests	64.3.3.6	Meets the requirements of Figure 64–19	OLT:M	Yes [ ]
SM8	Discovery Processing OLT Register	64.3.3.6	Meets the requirements of Figure 64–20	ONU:M	Yes [ ]
SM9	Discovery Processing OLT Final Registration	64.3.3.6	Meets the requirements of Figure 64–21	OLT:M	Yes [ ]
SM10	Discovery Processing ONU Registration	64.3.3.6	Meets the requirements of Figure 64–22	ONU:M	Yes [ ]
SM11	Report Processing at OLT	64.3.4.6	Meets the requirements of Figure 64–24	OLT:M	Yes [ ]
SM12	Report Processing at ONU	64.3.4.6	Meets the requirements of Figure 64–25	ONU:M	Yes [ ]
SM13	Gate Processing at OLT	64.3.5.6	Meets the requirements of Figure 64–27	OLT:M	Yes [ ]
SM14	Gate Processing at ONU	64.3.5.6	Meets the requirements of Figure 64–28	ONU:M	Yes [ ]
SM15	Gate Processing ONU Activation	64.3.5.6	Meets the requirements of Figure 64–29	ONU:M	Yes [ ]



#### 64.4.4.4 MPCP

Item	Feature	Subclause	Value/Comment	Status	Support
MP1	VLAN Tags	64.3.6	MPCPDU are not tagged	M	Yes [ ]
MP2	LLID for MPCPDU	64.3.6	RS generates LLID for MPCPDU	M	Yes [ ]
MP3	Grants during discovery	64.3.6.1	Single grant in GATE message during discovery	OLT:M	Yes [ ]
MP4	Grant start time	64.3.6.1	Grants within one GATE MPCPDU are sorted by their Start time values	OLT:M	Yes [ ]
MP5	TX during synchronization	64.3.6.1	Transmit IDLE code groups	ONU:M	Yes [ ]
MP6	GATE generation	64.3.6.1	GATE generated for active ONU except during discovery	OLT:M	Yes [ ]
MP7	GATE LLID	64.3.6.1	Unicast LLID except for discovery	OLT:M	Yes [ ]
MP8	REPORT issuing	64.3.6.2	Issues REPORT periodically	ONU:M	Yes [ ]
MP9	REPORT generation	64.3.6.2	Generated by active ONU	ONU:M	Yes [ ]
MP10	REPORT LLID	64.3.6.2	REPORT has unicast LLID	ONU:M	Yes [ ]
MP11	REGISTER_REQ generation	64.3.6.3	Generated by undiscovered ONU	ONU:M	Yes [ ]
MP12	REGISTER_REQ LLID	64.3.6.3	Use broadcast LLID	ONU:M	Yes [ ]
MP13	REGISTER DA address	64.3.6.4	Use individual MAC address	OLT:M	Yes [ ]
MP14	REGISTER generation	64.3.6.4	Generated for all ONUs	OLT:M	Yes [ ]
MP15	REGISTER_ACK generation	64.3.6.5	Generated by active ONU	ONU:M	Yes [ ]
MP16	REGISTER_ACK LLID	64.3.6.5	Use unicast LLID	ONU:M	Yes [ ]

1  
2  
3  
4  
5  
6  
7  
8  
9  
10  
11  
12  
13  
14  
15  
16  
17  
18  
19  
20  
21  
22  
23  
24  
25  
26  
27  
28  
29  
30  
31  
32  
33  
34  
35  
36  
37  
38  
39  
40  
41  
42  
43  
44  
45  
46  
47  
48  
49  
50  
51  
52  
53  
54

1  
2  
3  
4  
5  
6  
7  
8  
9  
10  
11  
12  
13  
14  
15  
16  
17  
18  
19  
20  
21  
22  
23  
24  
25  
26  
27  
28  
29  
30  
31  
32  
33  
34  
35  
36  
37  
38  
39  
40  
41  
42  
43  
44  
45  
46  
47  
48  
49  
50  
51  
52  
53  
54

1  
2  
3  
4  
5  
6  
7  
8  
9  
10  
11  
12  
13  
14  
15  
16  
17  
18  
19  
20  
21  
22  
23  
24  
25  
26  
27  
28  
29  
30  
31  
32  
33  
34  
35  
36  
37  
38  
39  
40  
41  
42  
43  
44  
45  
46  
47  
48  
49  
50  
51  
52  
53  
54

1  
2  
3  
4  
5  
6  
7  
8  
9  
10  
11  
12  
13  
14  
15  
16  
17  
18  
19  
20  
21  
22  
23  
24  
25  
26  
27  
28  
29  
30  
31  
32  
33  
34  
35  
36  
37  
38  
39  
40  
41  
42  
43  
44  
45  
46  
47  
48  
49  
50  
51  
52  
53  
54