

## IEEE 802.3 Ethernet Task Force Liaison Communication

Source: IEEE 802.3 Working Group<sup>1</sup>

To: Albrecht Oehler      Convenor, ISO/IEC JTC 1/SC25/WG3  
[albrecht.oehler@fh-reutlingen.de](mailto:albrecht.oehler@fh-reutlingen.de)

Paul Nikolich      Chair, IEEE 802 LMSC  
[p.nikolich@ieee.org](mailto:p.nikolich@ieee.org)

Adam Healey      Vice-chair, IEEE 802.3 Ethernet Working Group  
[adam.healey@avagotech.com](mailto:adam.healey@avagotech.com)

CC: Pete Anslow      Secretary, IEEE 802.3 Ethernet Working Group  
[panslow@ciena.com](mailto:panslow@ciena.com)

Chad Jones      Chair, IEEE P802.3bt Task Force  
[cmjones@cisco.com](mailto:cmjones@cisco.com)

Alan Flatman      Liaison Officer, IEEE 802.3 & ISO/IEC JTC 1/SC 25/WG 3  
[a\\_flatman@tiscali.co.uk](mailto:a_flatman@tiscali.co.uk)

From: David Law      Chair, IEEE 802.3 Ethernet Working Group  
[dlaw@hpe.com](mailto:dlaw@hpe.com)

Subject: Reply to Incoming Liaison 25N2545, remote powering

Approval: Approved at IEEE 802.3 Plenary meeting, Macau SAR, PRC, 17<sup>th</sup> March 2016

Dear Dr. Oehler,

IEEE 802.3 would like to thank you for your reply 25N2545. You asked for some further clarification, and our responses follow.

- 1) Will power be disconnected concurrently on all 4 pairs?

There are two allowable approaches: one that electronically switches the 4 pairs together and one that electronically switches each 2 pairs independently (1-2, 3-6 and 4-5, 7-8). The approach that electronically switches the 2 pairs independently are allowed to have two instances of the power supply. The standard has a requirement that the voltage difference between the two instances is 10 mV max.

- 2) Will power be disconnected separately 2 pairs at a time?

Breaking the circuit, and pin order in which this takes place, is completely dependent on the connector.

- 3) Is it possible for one or more conductors to carry the total four pair current for short period during disconnection?

Two conductors may each carry the total four pair current for short periods of time during disconnect. The spec requires the PSE current limit to be below 1.75 A within 8.2 ms and then is electronically disconnected within 75 ms.

---

<sup>1</sup> This document solely represents the views of the IEEE 802.3 Working Group, and does not necessarily represent a position of the IEEE, the IEEE Standards Association, or IEEE 802.

Additionally, please see the models below to assist you in simulating disconnection under load.

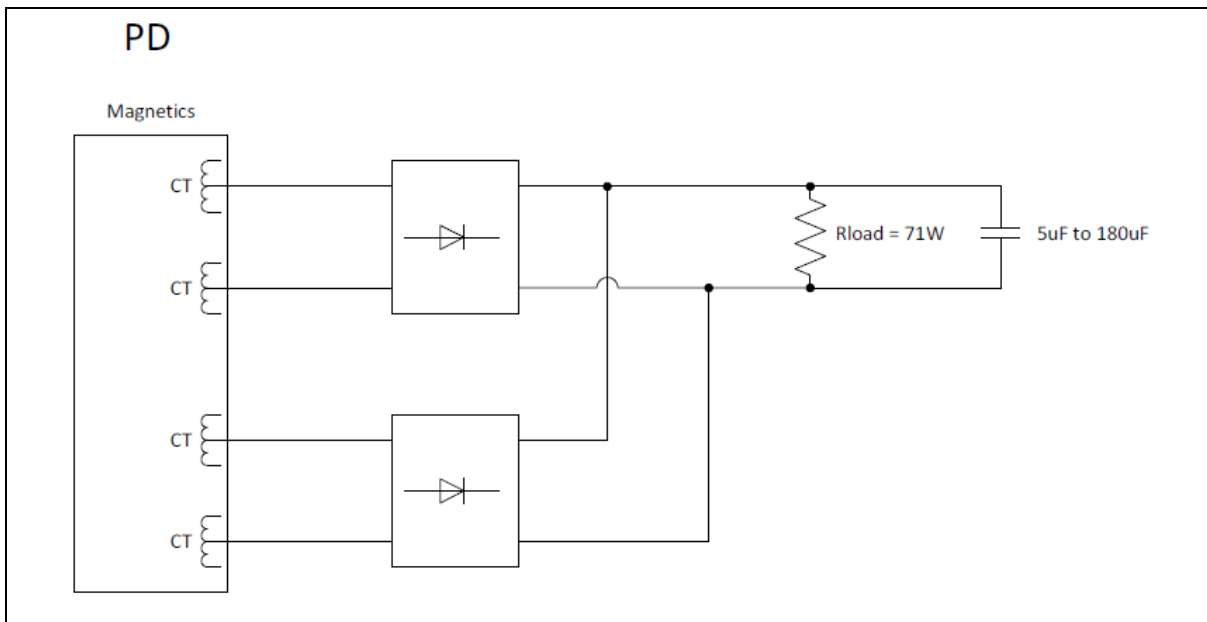
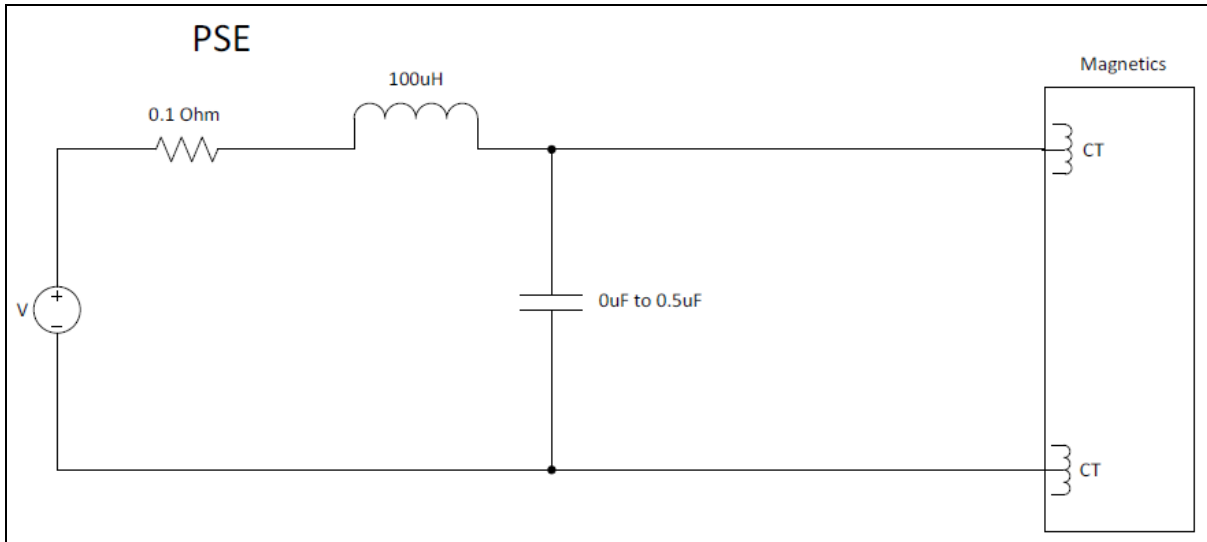

Thank you for the update on the status of ISO/IEC TR 29125 and confirmation that it has been elevated to a PDTR. Also thank you for providing a copy of the document for our review. It has been posted to the IEEE 802.3 private area and the link has been provided to the IEEE P802.3bt Task Force. There are no questions or comments at this time but any feedback we have will be provided after our next meeting the week of 23<sup>rd</sup> May 2016.

Sincerely,

David Law

Chair, IEEE 802.3 Ethernet Working Group